



OPERATOR'S MANUAL



GENERATOR
G625RS T4F

EN - 9841/2117 ISSUE 2 - 10/2020

THIS MANUAL SHOULD ALWAYS STAY WITH THE MACHINE



OPERATOR'S MANUAL

GENERATOR
G625RS T4F

EN - 9841/2117 - ISSUE 2 - 10/2020

This manual contains original instructions, verified by the manufacturer (or their authorized representative).

Copyright 2020 © JCB SERVICE
All rights reserved. No part of this publication may be reproduced, stored in a retrieval system, or transmitted in any form or by any other means, electronic, mechanical, photocopying or otherwise, without prior permission from JCB SERVICE.

www.jcb.com

Foreword

The Operator's Manual



You and others can be killed or seriously injured if you operate or maintain the machine without first studying the Operator's Manual. You must understand and follow the instructions in the Operator's Manual. If you do not understand anything, ask your employer or JCB dealer to explain it.

Do not operate the machine without an Operator's Manual, or if there is anything on the machine you do not understand.

Treat the Operator's Manual as part of the machine. Keep it clean and in good condition. Replace the Operator's Manual immediately if it is lost, damaged or becomes unreadable.

California Proposition 65

▲ WARNING Diesel engine exhaust and some of its constituents are known to the State of California to cause cancer, birth defects, and other reproductive harm.

Machine Delivery and Installation

Even if you have operated this type of equipment before, it is very important that your new machines operations and functions are explained to you by a JCB Dealer Representative following delivery of your new machine.

Following the installation you will know how to gain maximum productivity and performance from your new product.

Please contact your local JCB dealer if the Installation Form (included in this manual) has not yet been completed with you.

Your local JCB Dealer is



Notes:



Contents	Page No.
Acronyms Glossary	iv
Introduction	
About this Manual	
Model and Serial Number	1
Using the Manual	1
Left-Hand Side, Right-Hand Side	1
Cross References	2
Location of Manual	2
Safety	
Safety - Yours and Others	3
Safety Warnings	3
General Safety	3
About the Product	
Introduction	
Name and Address of the Manufacturer	5
Product Compliance	5
Description	
Main Component Locations	6
Product and Component Identification	
General	8
Engine	8
Safety Labels	
General	10
Safety Label Identification	10
Installation and Removal	
Installation	12
Operation	
Operating Safety	
General	15
Battery Isolator	
General	17
Before Starting the Engine	
General	18
Starting the Engine	
General	20
Stopping the Engine	
General	24
Instruments	
General	25
Control Panel	26
Module Display	55
Lifting the Machine	
General	62
Refueling	
Filling the Tank	63
Attachments	
Trailers	
General	65



Preservation and Storage

Cleaning
General 67
Security
LiveLink 68

Maintenance

Introduction
General 69
Maintenance Safety
General 70
Fluids and Lubricants 71
Maintenance Schedules
General 75
How to Use the Maintenance Schedules 75
Maintenance Intervals 75
Pre-start Cold Checks, Service Points and Fluid Levels 75
Maintenance Positions
Maintenance Position 78
Access Apertures
General 79
Engine
General 80
Oil 81
Front End Accessory Drive (FEAD) Belt 83
Alternator 85
Emissions Control System 86
Air Filter
General 88
Dust Valve 88
Fuel System
General 90
Primary Fuel Filter 90
Secondary Fuel Filter 92
Cooling System
General 93
Coolant 93
Cooling Pack 93
Wheels
General 95
Tires
General 97
Electrical System
General 98
Battery 98

Technical Data

Static Dimensions
Dimensions 101
Weights 101
Noise Emissions
Noise Data 102



Fluids, Lubricants and Capacities	
General	103
Fuel	103
Diesel Exhaust Fluid (DEF)	106
Coolant	108
Torque Values	
General	109
Electrical System	
General	110
Schematic Circuit	111
Engine	
General	112
Engine Emissions	112
Exhaust After Treatment (EAT)	112
Wheels and Tires	
Tire Sizes and Pressures	116
Warranty Information	
General	117

Acronyms Glossary

ATS	Automatic Transfer Switch
AVR	Alternator Voltage Regulator
CAN	Controller Area Network
DEF	Diesel Exhaust Fluid
DPF	Diesel Particulate Filter
DTC	Diagnostic Trouble Code
EAT	Exhaust After Treatment
ECU	Electronic Control Unit
EMS	Electronic Monitoring System
ESP	Emergency Standby Power
FEAD	Front End Accessory Drive
ISO	International Organization for Standardization
LCD	Liquid Crystal Display
LED	Light Emitting Diode
MCB	Miniature Circuit Breaker
MCCB	Molded Case Circuit Breaker
NOx	Nitrogen Oxide
RPM	Revolutions Per Minute
SCR	Selective Catalytic Reduction
USB	Universal Serial Bus

Introduction

About this Manual

Model and Serial Number

This manual provides information for the following model(s) in the JCB machine range:

Table 1.

Model	VIN Prefix.
G625 [HXN]	HXNEDS4P

Using the Manual

The quick start guide (if supplied) with the machine does not replace the operator's manual. You must read all the disclaimers and safety instructions in the operator's manual before initially operating the machine.

This operator's manual is arranged to give you a good understanding of the machine and its safe operation. It also contains maintenance and technical data.

Read this manual from the front to the back before you use the machine for the first time, even if you have used machines of a similar/same type before as the technical specification, systems and controls of the machine may have changed. Particular attention must be given to all the safety aspects of operating and maintaining the machine.

If there is anything you are not sure about, ask your JCB dealer or employer. Do not guess, you or others could be killed or seriously injured.

The general and specific warnings in this section are repeated throughout the manual. Read all the safety statements regularly, so you do not forget them. Remember that the best operators are the safest operators.

The illustrations in this manual are for guidance only. Where the machines are different, the text and or the illustration will specify.

The manufacturer's policy is one of continuous improvement. The right to change the specification of the machine without notice is reserved. No responsibility will be accepted for discrepancies which may occur between specifications of the machine and the descriptions contained in this manual.

All of the optional equipment included in this manual may not be available in all territories

Left-Hand Side, Right-Hand Side

References to the left side and right side of the engine are when viewed from the exhaust system end of the generator.

Figure 1.

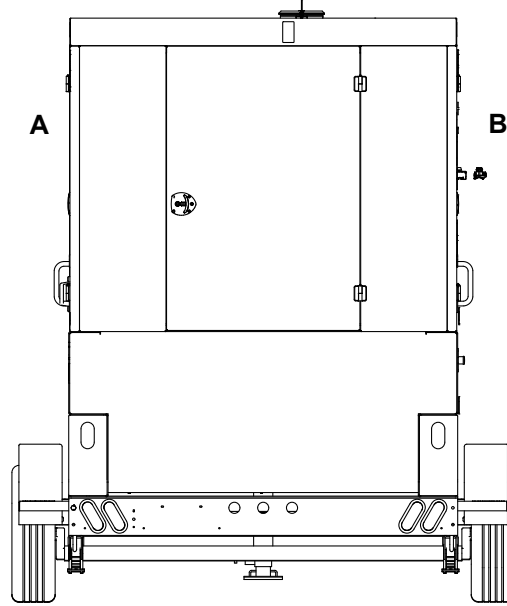

A Left

B Right

Cross References

In this manual, cross references are made by presenting the subject title in blue (electronic copy only). The number of the page upon which the subject begins is indicated within the brackets. For example: [Refer to: Cross References \(Page 2\)](#).

Location of Manual

The manual is located in the case behind the door. The manual should always be returned to its case after use.

Figure 2.

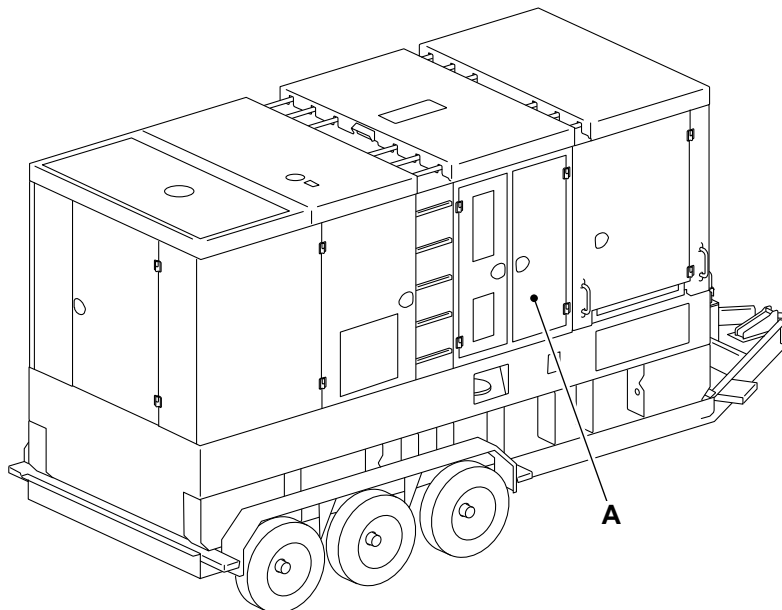

A Operator manual case

Safety

Safety - Yours and Others

All machinery can be hazardous. When a machine is correctly operated and maintained, it is a safe machine to work with. When it is carelessly operated or poorly maintained it can become a danger to you (the operator) and others.

In this manual and on the machine you will find warning messages, you must read and understand them. They inform you of potential hazards and how to avoid them. If you do not fully understand the warning messages, ask your employer or JCB dealer to explain them.

Safety is not just a matter of responding to the warnings. All the time you are working on or with the machine you must be thinking of what hazards there might be and how to avoid them.

Do not work with the machine until you are sure that you can control it.

Do not start any work until you are sure that you and those around you will be safe.

If you are not sure of anything, about the machine or the work, ask someone who knows. Do not assume anything.

Remember:

- Be careful
- Be alert
- Be safe.

Safety Warnings

In this manual there are safety notices. Each notice starts with a signal word. The signal word meanings are given below.

The signal word 'DANGER' indicates a hazardous situation which, if not avoided, will result in death or serious injury.

The signal word 'WARNING' indicates a hazardous situation which, if not avoided, could result in death or serious injury.

The signal word 'CAUTION' indicates a hazardous situation which, if not avoided, could result in minor or moderate injury.

The signal word 'Notice' indicates a hazardous situation which, if not avoided, could result in machine damage.

The safety alert system symbol (shown) also helps to identify important safety messages in this manual. When you see this symbol your safety is involved, carefully read the message that follows.

Figure 3. The safety alert system symbol



General Safety

The following safety checklist is intended to help remind you of safety procedures and practices.

Safety is Your Responsibility

You must also refer to local regulations in the country your equipment is being used in. Some of the information may be repeated in the following warnings and cautions pages and in the main text.

- Do not change the application or specification of the generator. Install the generator in accordance with recommendations made in the generator Installation Manual. – Do not lift heavy objects on your own, use lifting equipment or obtain the help of an assistant.
- Do not smoke when adding fuel to the tank or working in the generator bay area.
- Always clean up spilt fluids, dispose of fluids, contaminated material etc. in accordance with local regulations. Do not pollute drains or the ground. – Use the right tools for the job. – Always make the equipment safe before completing any maintenance tasks, for instance disconnect the battery so that the generator can not be started.
- Allow generator components to cool before attempting any maintenance tasks, components such as the exhaust can become extremely hot.
- Do not adjust the generator, or add fuel, oil whilst it is running unless procedures in this manual instruct you to do so.
- Do not siphon fluids by mouth.
- Operate the generator in well ventilated areas, if using indoors then a purpose designed exhaust fume extraction unit may be needed. – Keep other people at a safe distance when operating the generator or equipment.
- Do not operate an generator if the safety guard (when applicable) has been removed.
- Vapors from solvents, thinners and adhesives can be highly flammable. In addition to fire risk, they can be toxic and in certain conditions cause unconsciousness, or death if inhaled. Use these items in well ventilated areas.
- Seek medical advice immediately if your skin contacts high pressure fuel.
- Make sure the generator is operated by one person correctly positioned at the controls.
- Do not operate the generator at high speeds with no load applied.
- Make sure you have adequate fire fighting equipment in your workshop, repair area. Contact your local fire prevention officer for advice.
- Turbocharger impeller blades operate at extremely high revolutions and the turbocharger unit becomes very hot. Allow the unit to cool before completing any maintenance. Keep tools and objects away from the impeller when the unit is operating.
- Use only JCB recommended parts. These parts have been designed to give the generator its optimum performance. Using spurious parts may affect the integrity of the generator.

About the Product

Introduction

Name and Address of the Manufacturer

JCB Power Products Limited, Lakeside Works, Rocester, Uttoxeter, United Kingdom, ST145JP

Product Compliance

Your JCB product was designed to comply with the laws and regulations applicable at the time of its manufacture for the market in which it was first sold. In many markets, laws and regulations exist that require the owner to maintain the product at a level of compliance relevant to the product when first produced. Even in the absence of defined requirements for the product owner, JCB recommend that the product compliance be maintained to ensure safety of the operator and exposed persons and to ensure the correct environmental performance. Your product must not be altered in any way which could affect or invalidate any of these requirements. For advice consult your JCB dealer.

For its compliance as a new product, your JCB and some of its components may bear approval numbers and markings, and may have been supplied with a Declaration/Certificate of Conformity. These markings and documents are relevant only for the country/region in which the product was first sold to the extent that the laws and regulations required them.

Re-sales and import/export of products across territories with different laws and regulations can cause new requirements to become relevant for which the product was not originally designed or specified. In some cases, pre owned products irrespective of their age are considered new for the purposes of compliance and may be required to meet the latest requirements which could present an insurmountable barrier to their sale/use.

Despite the presence of any compliance related markings on the product and components, you should not assume that compliance in a new market will be possible. In many cases it is the person responsible for import of a pre owned product into a market that becomes responsible for compliance and who is also considered the manufacturer.

JCB may be unable to support any product compliance related enquiry for a product which has been moved out of the legislative country/region where it was first sold, and in particular where a product specification change or additional certification would have been required in order for the product to be in compliance.

Description

Main Component Locations

Figure 4.

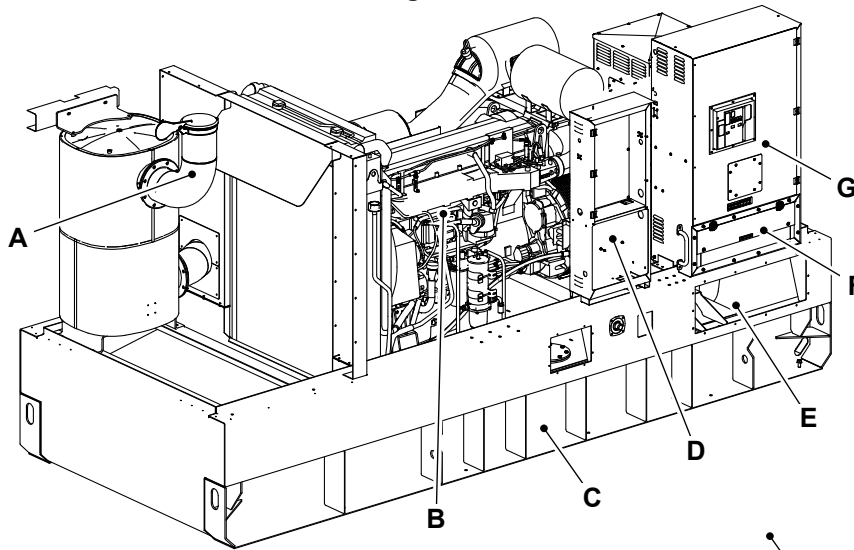

- A Exhaust system
- C Skid
- E Camlock connections
- G Breaker box

- B Engine
- D Control panel
- F Power cables exit

Figure 5.

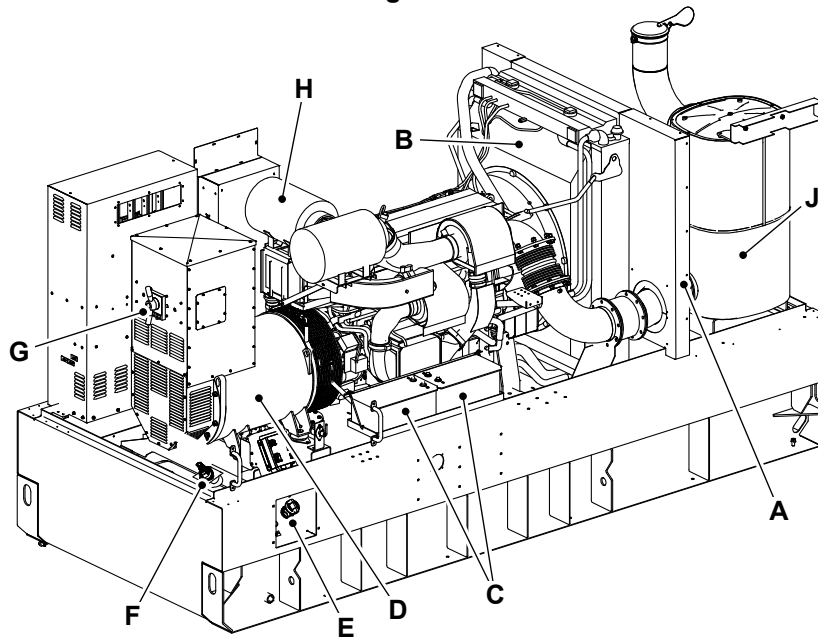

- A Bulkhead
- C Battery
- E Fuel tank filler
- G Voltage control rotary switch
- J SCR (Selective Catalytic Reduction)

- B Radiator
- D Alternator
- F DEF (Diesel Exhaust Fluid) tank filler
- H Air filter

Figure 6.

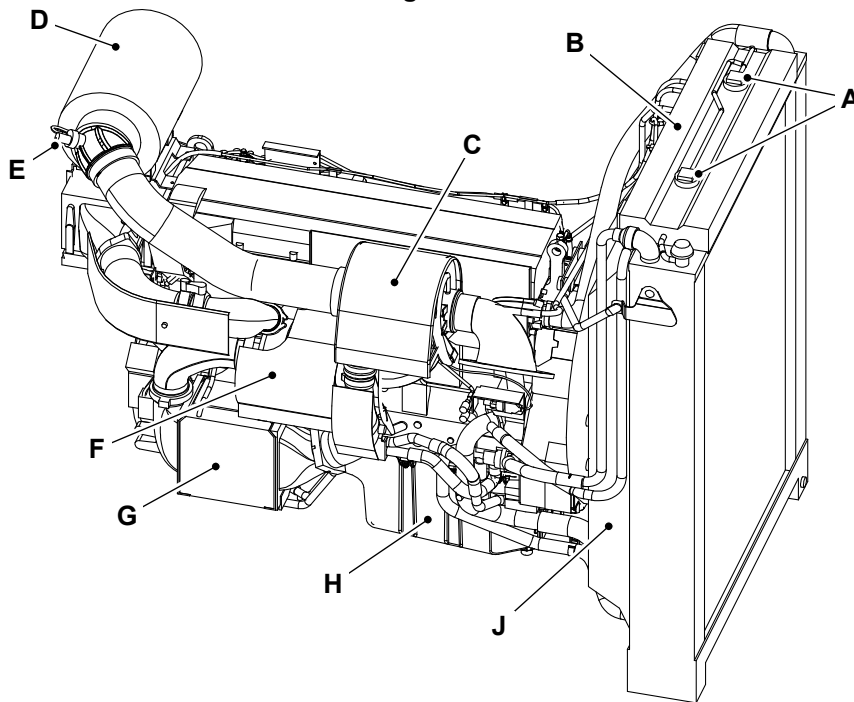

- | | |
|---|-------------------------------------|
| A Coolant filler | B Expansion tank |
| C High-pressure turbo charger | D Air filter |
| E Air filter indicator | F Low-pressure turbo charger |
| G Charge air cooler (low pressure turbo) | H Oil sump |
| J Radiator | |

Figure 7.

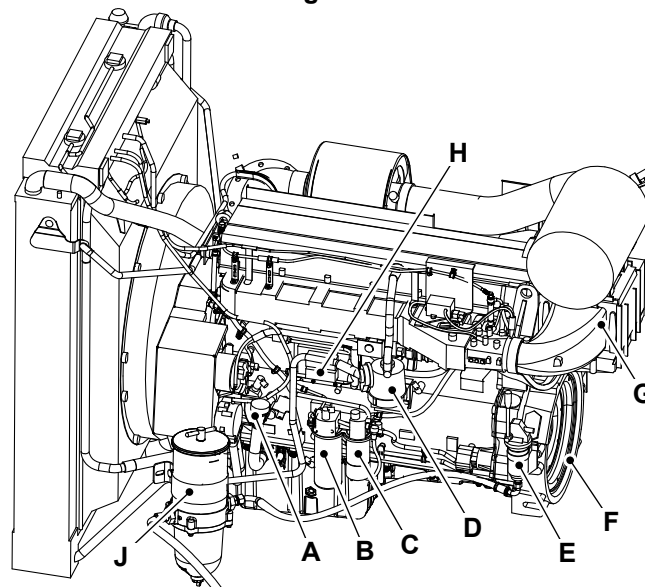

- | | |
|--|---|
| A Engine oil filler | B Fuel pre-filter |
| C Fuel filter | D Crankcase ventilation |
| E Oil drain pump | F Flywheel housing |
| G Charge air cooler (high pressure turbo) | H EMS (Electronic Monitoring System) |
| J Main fuel filter | |

Product and Component Identification

General

The data plate details the model designation, rating, weight, year of manufacture, output rating and other generating set specific information. The data plate and service plate are located in the control panel compartment. Refer to Figure 8.

The identification plate may vary by region due to the legislative requirements.

Figure 8. Identification Plate

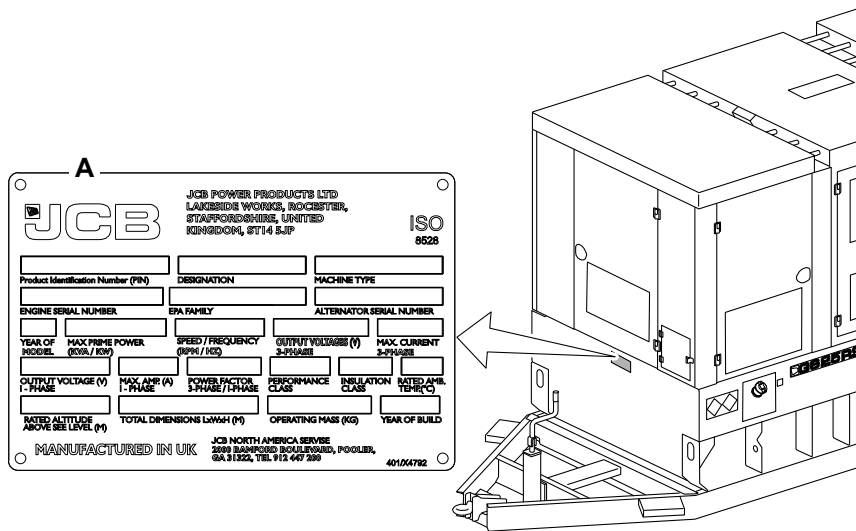

A Data plate

Engine

The engine data labels are placed on the valve cover. Refer to Figure 9.

Figure 9.

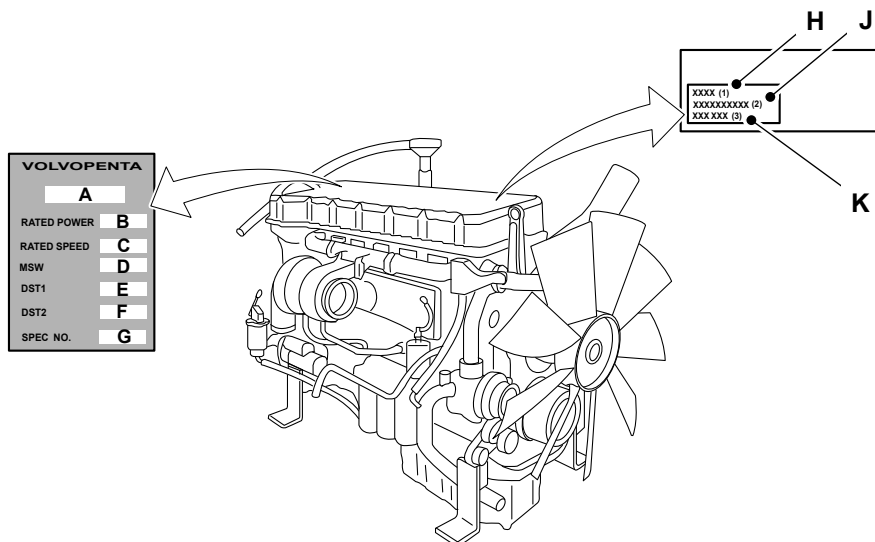

- A Engine designation
- C Maximum engine speed
- E Data set 1
- G Product number
- J Serial number

- B Engine power, net, (without fan)
- D Main software
- F Data set 2
- H Engine designation
- K Specification number

Table 2. Explanation of Engine Designation

Example: TAD1641GE/TAD941VE	
T	Turbo
A	Air to air intercooler
D	Diesel engine
16	Cylinder volume, liter
4	Generation
1	Version
G	Generator unit engine
V	Stationary and mobile operation
E	Emission certified

Safety Labels

General

▲ **WARNING** Safety labels on the machine warn you of particular hazards. You can be injured if you do not obey the safety instructions shown.

The safety labels are strategically placed around the machine to remind you of possible hazards.

If you need eye-glasses for reading, make sure you wear them when reading the safety labels. Do not overstretch or put yourself in dangerous positions to read the safety labels. If you do not understand the hazard shown on the safety label, then refer to Safety Label Identification.

Keep all of the safety labels clean and readable. Replace a lost or damaged safety label. Make sure the replacement parts include the safety labels where necessary. Each safety label has a part number printed on it, use this number to order a new safety label from your JCB dealer.

Safety Label Identification

Figure 10.

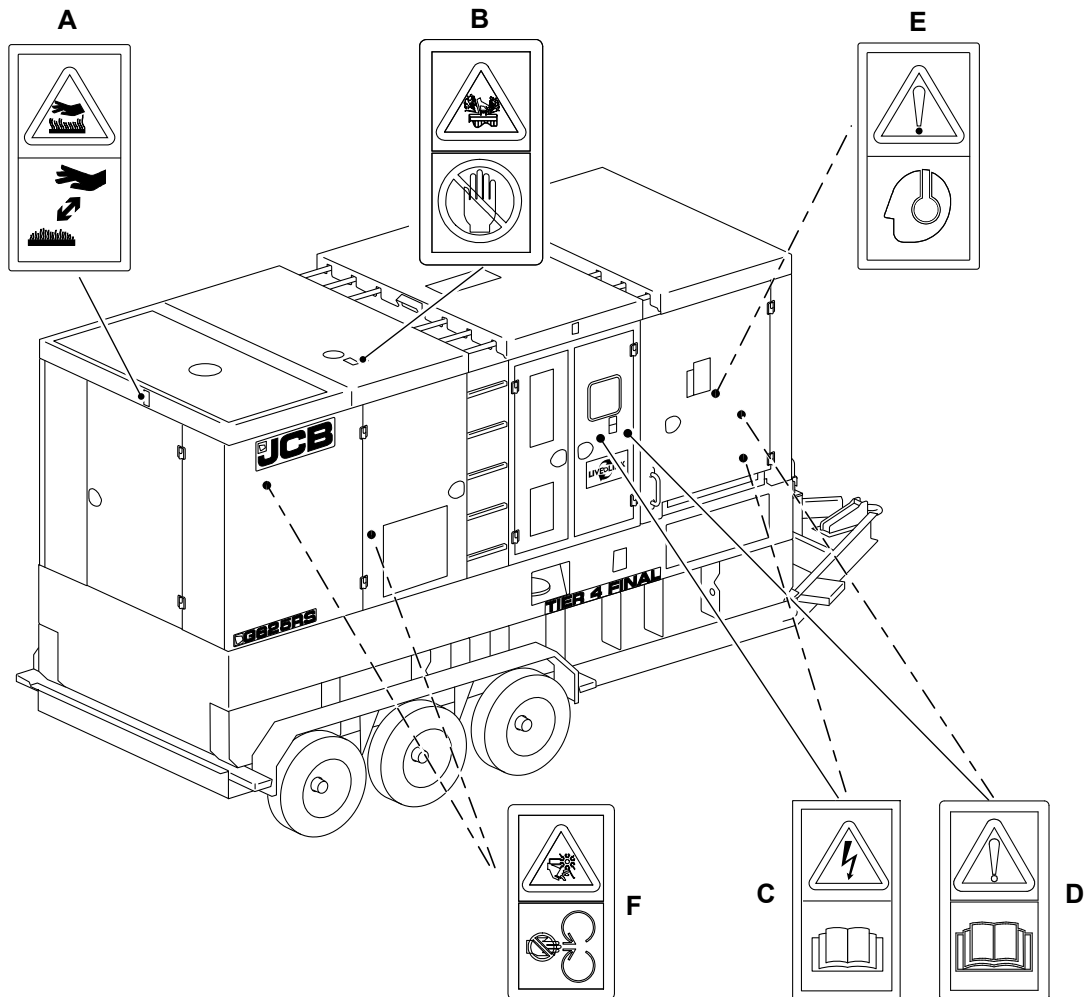

Table 3. Safety Labels

Item	Part No.	Description	Qty.
A	817/70004	Warning. Burns to fingers and hands. Stay a safe distance away.	1
B	817/70005	Hot fluid under pressure. Do not touch, consult operator's manual.	1
C	817/70032	Electrical hazard. Read the Operator's Manual.	2



Item	Part No.	Description	Qty.
D	817/70014	Warning. Read the Operator's Manual before you operate the machine.	2
E	332/P4712	Noise warning. Wear ear protection.	1
F	332/P4581	Warning. Severing of hands and fingers. Keep clear of/do not reach into rotating parts.	2

Installation and Removal

Installation

Sparks

Explosions and fire can be caused by sparks from the exhaust or the electrical system. Do not use the machine in closed areas where there is flammable material, vapor or dust.

Unpacking

Your JCB generator will arrive with a protective wrapping in place. Take care while removing this packaging with a knife/scissors. Do not damage the underlying paint work or wiring looms of the machine. Remove any wooden plinths that have been installed to the base of the unit for packing before installation.

For larger machines, and sometimes for shipping purposes, the silencer unit may be supplied loose. If this is the case, make sure that there is correct coupling of the silencer to the exhaust manifold before operation.

Make sure that all the joints along the length of the exhaust system have a U-clamp or other suitable mechanical fixing and are secure to provide correct jointing of the exhaust components.

Installation

Generators are installed can be installed in to different standards of wiring and safety systems. It is owner's responsibility to ensure that the safety and compliance of the electrical system connected to the generator. JCB is not responsible for the load or the electrical systems connected to the generator.

Site Installation

The generating set should be located on suitable foundations. A level concrete surface designed to carry the weight of the generating set is ideal (if unsure contact a structural engineer). All electrical and fuel ducting to and from the machine should be professionally installed. All wiring to the terminal box, and through other panels should be installed using the appropriate cable glands.

The generating set should be located to provide suitable access for regular maintenance, servicing and repair work.

The generating set should only be lifted using the central lifting eye or forklift pocket or via the canopy/container lifting points or four point lift in the base utilising certified lifting equipment with spreaders. Do not lift the unit by the alternator or engine lifting eyes. These are designed only to carry the weight of the specific unit (engine or alternator) and not for the weight of the fully assembled generating set.

Remote Fuel Tank Installation

If a remote fuel tank is used to supply fuel to the generator this must be located in close proximity to the generator. If the tank is installed significantly below the level of the generator, or if long and/or narrow bore hoses are used for the fuel feed hose then fuel starvation may result. This is identified by decreased power and excessive smoke.

Care must be taken when connecting a remote tank. All connections must be securely attached and fully sealed. Air ingress caused by poor connections can cause significant damage to the fuel injection pump on the engine and normally results in engine hunting and smoking.

Electrical installation should be carried out in accordance with JCB schematics supplied with the specific generating system and by suitably competent person only. If in doubt about any aspect of installation contact your JCB dealer.

Configuration of the remote fuel level sender is the responsibility of the installer.

Outdoor Installations

Generator sets which are installed outdoors (excluding soundproof sets, that are intended for such applications), must be located in a place which is protected against weather conditions, dust, etc. as much as possible.

For temporary installations, the generator set can rest on a well-leveled surface. For long-term installations, it is advisable to build a concrete base.

Adequate airflow is critical to the correct operation of the generating set. Outdoor installation should allow for suitable clearance between air inlets and outlets to maintain the correct ventilation. As a guideline when installing a containerised set outdoors maintain a clearance of at least 1.5m (1½yd) around the unit. This is for guidance only. For more detailed information contact your JCB dealer. It is also important to note that placing the unit close to solid surfaces e.g. concrete walls may cause an increase in noise and cooling problems.

Figure 11.

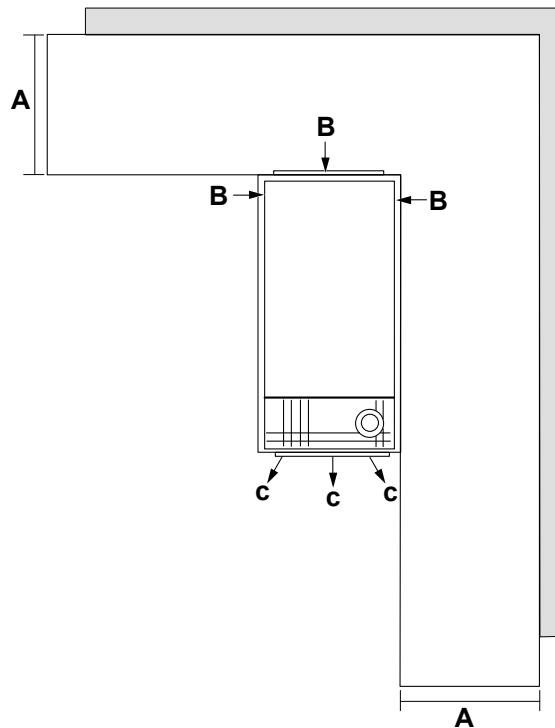

A Distance from wall = 1,500mm (59in)
C Air outlet

B Air inlet

Basic Elements to be Considered

- Foundations
- Exhaust installations
- Ventilation
- Fuel installation
- Electrical connections
- Grounding
- Heating

Foundations

Foundations must prevent the transmission of vibrations and noise to other parts of the building.

The surface on which the set will be placed must be leveled in order to allow its correct operation.

Ventilation

Adequate ventilation is essential for correct operation and durability of the generator set.

- Allow the heat produced by operation of the generator to be dissipated by radiation and convection.
- Provide sufficient air flow for engine combustion and cooling.
- Provide adequate air for the health and safety of the operator.



Heating

Electric heaters with thermostatic controls ranging from 500W (0.7hp) to 1,500W (2.0hp) are available for cold climates.

Where necessary, battery chargers and heaters should be connected to a voltage supply. Auxiliary socket is located on the control panel.

Fuel Supply System

The generator set is supplied with an integral fuel supply system with a fuel tank located on the bed plate.

The maximum permissible pressure for the fuel feed line is 0.15bar (2.2psi).

The maximum permissible pressure for the return line is 0.05bar (0.7psi).

The fuel tank is connected to the engine by flexible pipework suitable for normal operating conditions.

In especially arduous conditions a separate fuel tank may be required. This must be connected to the engine using suitable pipework to ensure that the fuel injection pump can draw fuel correctly.

Electrical Connections

The generator set cables must be correctly connected as shown on the electrical schematics.

Grounding

Metal parts that may be exposed to human contact must be connected to ground.

Suitable protective conductor connections should be made in accordance with local regulations.

Operating Generators in Extreme Cold Climates

Certain preparations must be made to enable engine starting in extreme cold, and in some cases to make starting possible at all:

- Use a fuel that is approved for the prevailing temperature. This reduces the risk of paraffin wax precipitation in the fuel system.
- Use a synthetic engine oil of a viscosity recommended for the prevailing temperature to achieve satisfactory lubrication. Synthetic lubricants are able to handle a wider temperature range than mineral based lubricants.
- Pre-heat the coolant with a separately installed electric engine heater. In extreme cases, a diesel fired engine heater may be necessary.
- Make sure the cooling system is filled with a glycol mixture. The batteries must be in good condition. Cold weather reduces battery capacity. Increased battery capacity may be necessary.

Select the oil viscosity according to the table. The temperature values refer to stable ambient temperatures. * SAE 5W/30 refers to synthetic or semi-synthetic oils.

Table 4. Lubricant Temperature Compatibility

Lubricant	Temperature Range
SAE 15W40	-15–46°C (5.0–114.7°F)
SAE 10W30	-25–20°C (-13.0–68.0°F)
SAE 5W30	-46–20°C (-50.7–68.0°F)
SAE 20W30	-10–20°C (14.0–68.0°F)
SAE 30	0–30°C (32.0–86.0°F)
SAE 40	10–46°C (50.0–114.7°F)

Operating Safety

General

Care and Alertness

All the time you are working with or on the machine, take care and stay alert. Always be careful. Always be alert for hazards.

Clothing

You can be injured if you do not wear the correct clothing. Loose clothing can get caught in the machinery. Keep cuffs fastened. Do not wear a necktie or scarf. Keep long hair restrained. Remove rings, watches and personal jewelry.

Lifting Equipment

You can be injured if you use incorrect or faulty lifting equipment. You must identify the weight of the item to be lifted then choose lifting equipment that is strong enough and suitable for the job. Make sure that lifting equipment is in good condition and complies with all local regulations.

Training

Make sure that you have had adequate training and that you are confident in your ability to operate the machine safely before you use it. Practice using the machine and its attachments until you are completely familiar with the controls and what they do. With a careful, well trained and experienced operator, your machine is a safe and efficient machine. With an inexperienced or careless operator, it can be dangerous. Do not put your life, or the lives of others, at risk by using the machine irresponsibly. Before you start to work, tell your colleagues what you will be doing and where you will be working. On a busy site, use a signalman.

Before doing any job not covered in this manual, find out the correct procedure. Your local JCB distributor will be glad to advise you.

Fuel

Fuel is flammable, keep naked flames away from the fuel system. Stop the engine immediately if a fuel leak is suspected. Do not smoke while refueling or working on the fuel system. Do not refuel with the engine running. Completely wipe off any spilt fuel which could cause a fire. There could be a fire and injury if you do not follow these precautions.

Communications

Bad communications can cause accidents. Keep people around you informed of what you will be doing. If you will be working with other people, make sure any hand signals that may be used are understood by everybody. Worksites can be noisy, do not rely on spoken commands.

Machine Condition

A defective machine can injure you or others. Do not operate a machine which is defective or has missing parts. Make sure the maintenance procedures in this manual are completed before using the machine.

Machine Limits

Operating the machine beyond its design limits can damage the machine, it can also be dangerous. Do not operate the machine outside its limits. Do not try to upgrade the machine performance with unapproved modifications or additional equipment.

Exhaust Gases

Machine exhaust gases can harm and possibly kill you or bystanders if they are inhaled. Do not operate the machine in closed spaces without making sure there is good ventilation. If possible, install an exhaust extractor. If you begin to feel drowsy, stop the machine at once and get into fresh air.

Sparks

Explosions and fire can be caused by sparks from the exhaust or the electrical system. Do not use the machine in closed areas where there is flammable material, vapor or dust.

Hazardous Atmospheres

This machine is designed for use in normal out door atmospheric conditions. It must not be used in an enclosed area without adequate ventilation. Do not use the machine in a potentially explosive atmosphere, i.e. combustible vapors, gas or dust, without first consulting your JCB dealer.

Regulations

Obey all laws, worksite and local regulations which affect you and your machine.

Hot Components

Touching hot surfaces can burn skin. The engine and machine components will be hot after the unit has been running. Allow the engine and components to cool before servicing the unit.

Alcohol and Drugs

It is extremely dangerous to operate machinery when under the influence of alcohol or drugs. Do not consume alcoholic drinks or take drugs before or while operating the machine or attachments. Be aware of medicines which can cause drowsiness.

Battery Isolator

General

▲ **Notice:** Before carrying out arc welding on the machine, disconnect the battery and alternator to protect the circuits and components. The battery must still be disconnected even if a battery isolator is installed.

Notice: Do not isolate the machine electrics when the engine is running, this may cause damage to the machine electrics.

The control system is designed such that if the battery isolator is switched off then there is a 2min time delay to de-energize the ECU (Electronic Control Unit) to allow the DEF (Diesel Exhaust Fluid) purge to complete its shutdown cycle.

Disconnect the Machine Electrics:

1. Get access to the battery isolator.

Figure 12.

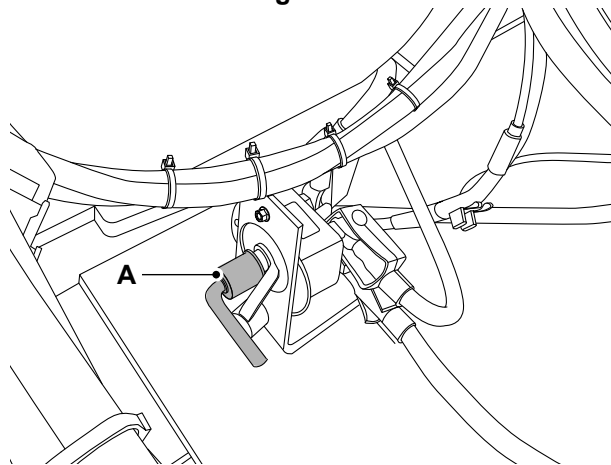

A Battery isolator key

2. Turn the battery isolator key in a counter-clockwise direction and remove.

Connect the Machine Electrics:

1. Insert the battery isolator key and turn in a clockwise direction.

Before Starting the Engine

General

After correct installation of the unit and the wiring, the generating set must be fully checked over before first starting can be attempted. Points to check include:

- Make sure that the battery isolator is at 'off' position before carrying out any checks.
- Check all belts, guards and panel covers are firmly secured.
- Check the installed wiring to ensure all connections are firmly installed in the correct position, and that wires are in good condition.
- Make sure that the battery connections are secure and polarity of connections are correct.
- Ensure that there is fuel in the fuel tank. Check the DEF (Diesel Exhaust Fluid). The system will only check DEF level at key on.
- If the machine has not been run previously, if it has run out of fuel or if the fuel supply has been reconnected then the fuel system must be primed prior to starting. Check for fuel leaks during this process.
- Check level of coolant in machine radiator, and top-up if low.
- Check hoses for damage or loose clamps.
- Check level of engine oil using dipstick.
- Check fuel filter/water separator for presence of water or contaminants.
- Check the position of the 3-way valve to correct fuel source. Do not run the generator with the 3-way valve set to the 'off' position.
- Visually inspect the engine and alternator for any signs of damage, water, oil or fuel leaks.
- Make sure that all supplied documents are kept in the document holder case.
- Ensure that machine intake and outlet air vents and grills are not obstructed or blocked in any way to allow good airflow through the machine.
- Check that the engine intake air filter is correctly fitted, and that there are no obstructions to the incoming air.
- Make sure that all the engine access doors are closed and secured.
- With the exception of emergency power generators, the engine should be warmed up with a reduced load before applying the full load.
- Check the multi-voltage section switch and configuration of breakers for your application.

3-Way Fuel Valve

Figure 13.

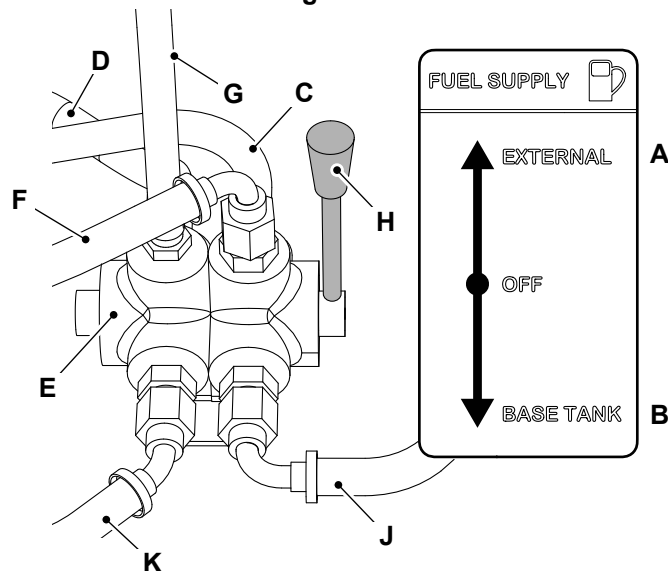

- | | |
|---|---|
| <p>A External tank</p> <p>C Forward line (Fuel tank suction to 3-Way fuel valve)</p> <p>E 3-Way fuel valve</p> <p>G Return line (Engine return to 3-Way fuel valve)</p> | <p>B Base tank</p> <p>D Return line (3-Way fuel valve outlet to fuel tank)</p> <p>F Forward line (3-Way fuel valve to lift pump inlet)</p> <p>H Direction lever</p> |
|---|---|

J Forward line (External fuel tank suction to 3-Way fuel valve)

K Return line (3-Way fuel valve outlet to external fuel tank)

Multi-voltage Selection

▲ Notice: A padlock must be installed to prevent accidental rotation of the multi voltage switch whilst the generator is running, otherwise damage will be caused to the alternator.

Figure 14.

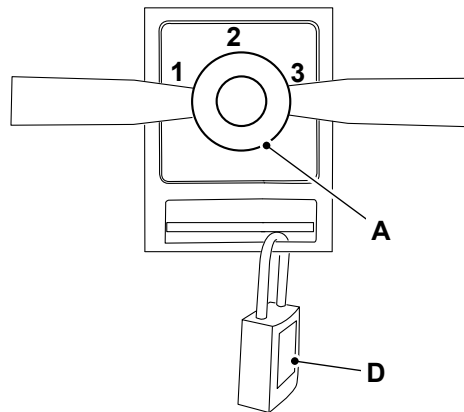

A Voltage control rotary switch
2 208/120V Three Phase
D Padlock

1 480/277V Three Phase
3 240/120V Single Phase

Checks After Running

Ensure that the electrical load is switched off before stopping the engine.

- Check that battery isolator is in the 'off' position.
- Fill the fuel and DEF tanks. Make sure that the filler caps and the area round the filler openings are clean to avoid contamination of the fuel and DEF.
- Make sure that all the engine access doors are closed and secured.
- Check the condition of the cooling system antifreeze.
- If necessary, prepare for the next start by connecting the cold climate equipment. .

Coolant should be topped up when the engine is stopped. Make sure that enough time is allowed for the engine/coolant to cool before the radiator cap is removed.

Starting the Engine

General

DEIF Control Panel

▲ Notice: Possibility of equipment damage. Proper sizing is critical to the operation and performance of the generator. Make sure that the load is sized correctly for the capacity of your generator and cables.

Perform all the pre-start checks before starting the generator. [Refer to: General \(Page 18\).](#)

Manual Mode

Figure 15.

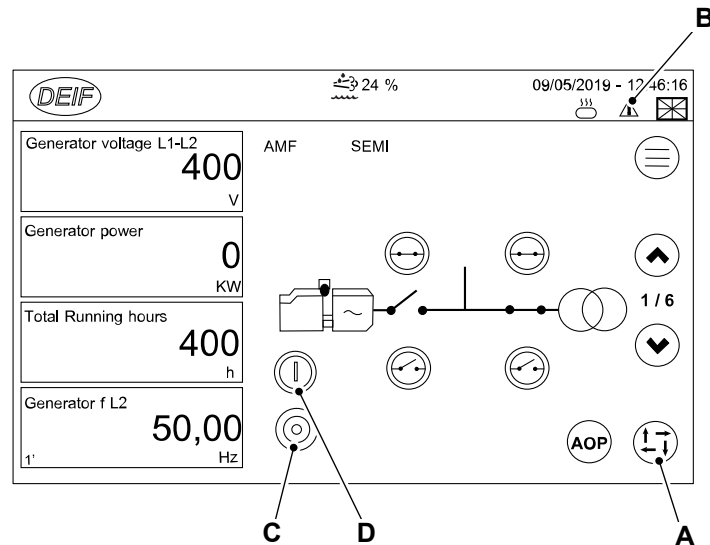

A Mode change
C Stop button

B Alarm shortcut
D Start button

1. Turn the battery isolator to the 'on' position. Controller will power up.
2. Use the alarm shortcut to reset any alarms that may be displayed on the controller. Check for any standing alarms and investigate as necessary before proceeding with start.
3. The machine can be run in manual or semi automatic dependent on the application. For remote start function the controller must be set to semi automatic mode by pressing the mode change button.
4. Press the start button. The generator controller will display the start-up sequence.
5. Engine will now crank and start to run.
6. Generator will now display engine and alternator status. It will change from red to a solid green to show that it is ready with no faults.
7. Check voltage and frequency on the controller.

Semi Automatic Mode

▲ WARNING The generator can start unexpectedly if the remote start signal is closed or shorted.

Semi automatic mode allows a generator to be controlled via a remote start signal generated by an ATS (Automatic Transfer Switch) or other remote switch.

Figure 16.

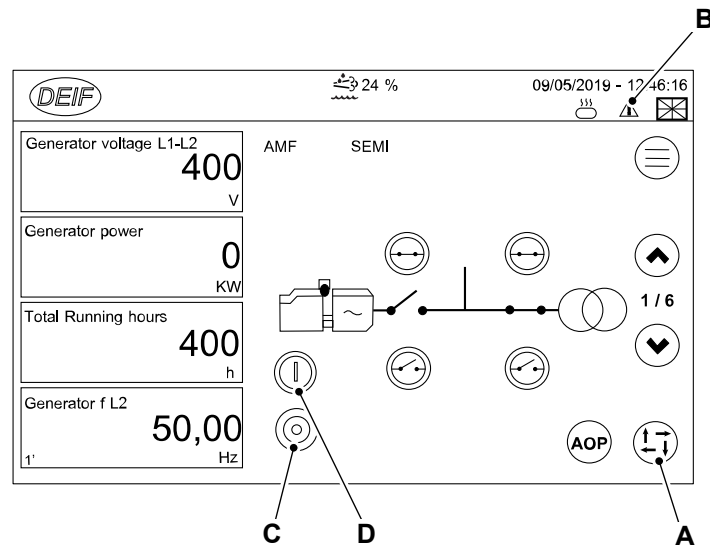

A Mode change
C Stop button

B Alarm shortcut
D Start button

Starting Procedure in Semi Automatic

1. Set the MCCB (Molded Case Circuit Breaker) to the 'on' position.
2. Turn the battery isolator to the 'on' position. Controller will power up.
3. Use the alarm shortcut to reset any alarms that may be displayed on the controller.
4. Press the mode change button to select semi-automatic mode.
5. When the generator receives a signal to start, the engine will crank and run. Generator will now display engine and alternator status. It will change from red to a solid green to show that it is ready with no faults.
6. Check voltage and frequency on the controller.
7. On removal of the automatic start signal the generator will automatically shutdown after a pre-determined cool down time and remain in an available state ready for the next remote start signal.

Remove from Standby

Perform the procedure below to remove generator from standby to carry out maintenance on the generator (generator on automatic mains fail and not running with mains healthy).

1. Press the mode change button to select manual mode.
2. Turn the battery isolator to the off position.

Deapsea Control Panel

▲ Notice: Possibility of equipment damage. Proper sizing is critical to the operation and performance of the generator. Make sure that the load is sized correctly for the capacity of your generator and cables.

Perform all the pre-start checks before starting the generator. [Refer to: General \(Page 18\).](#)

Manual Mode

Figure 17.

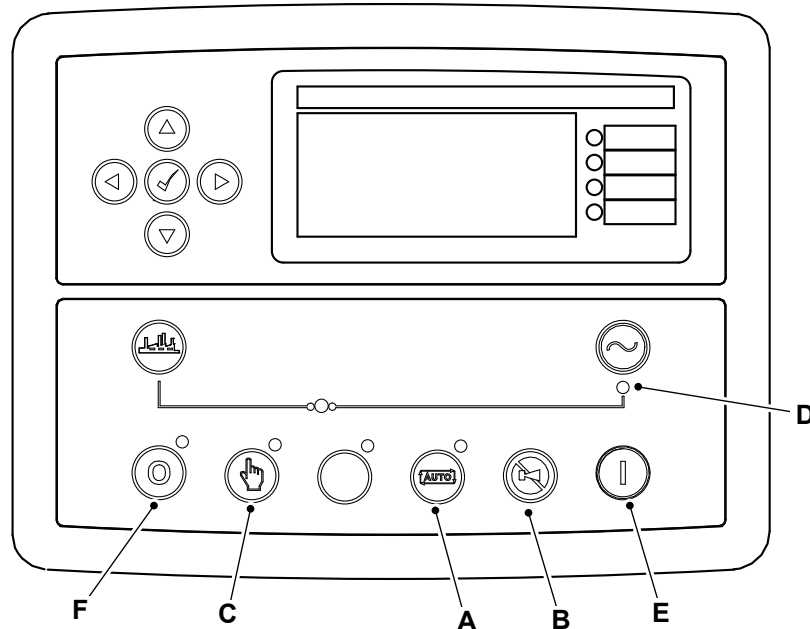

A Automatic mode button
C Manual mode
E Start button

B Alarm silence button
D Generator ready
F Stop/reset button

1. Turn the battery isolator to the 'on' position. Controller will power up.
2. Press the stop/reset button to clear any alarms that may be displayed on the controller.
3. Press the manual button.
4. Press the green activated start button. The generator controller will display the start-up sequence.
5. Engine will now crank and start to run.
6. Generator will now display generator available LED (Light Emitting Diode) to show that it is ready.
7. Check voltage and frequency on the controller.
8. Using the breaker control buttons on the controller set the MCCB to the 'on' position.

Automatic mode

▲ WARNING The generator can start unexpectedly if the remote start signal is closed or shorted.

Automatic mode allows a generator to be controlled via a remote start signal generated by an ATS or other remote switch.

Figure 18.

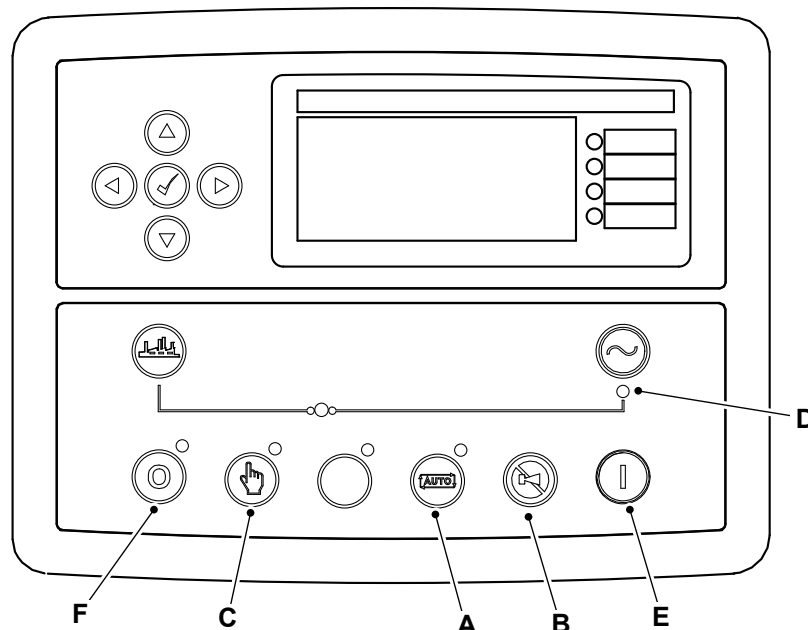

- | | |
|--------------------------------|-------------------------------|
| A Automatic mode button | B Alarm silence button |
| C Manual mode | D Generator LED |
| E Start button | F Stop/reset button |

Starting Procedure

1. Turn the battery isolator to the 'on' position. Controller will power up.
2. Press the stop/reset button to clear any alarms that may be displayed on the controller.
3. Press the 'auto mode' button. The LED is illuminated.
4. Once cabled up, the signal to start the generator will come from the automatic mains fail system. It is recommended that a full test is carried out to prove function.
5. When the generator receives a signal to start, the engine will crank and run. The controller will show the generator running LED under the generator symbol (D). The ready to load LED will illuminate on the programable LED.
6. Check voltage and frequency on the controller.
7. The generator can now be returned to stand-by mode by removing the automatic mains fail start signal. The generator will now go through the shutdown procedure.
8. Close all doors and access panels. This will now be ready for auto start operation.

Remove from Standby

Perform the procedure below to remove generator from standby to carry out maintenance on the generator (generator on automatic mains fail and not running with mains healthy).

1. Press the stop/reset button.
2. Turn the battery isolator to the off position.

Stopping the Engine

General

Emergency stop button

A machine isolation button/emergency stop button is mounted externally on the canopy. If pressed, all machine systems will stop completely.

Use the emergency stop button in the case of an emergency or if the machine becomes unsafe and does not shutdown automatically. Refer to Figure 19.

Figure 19.

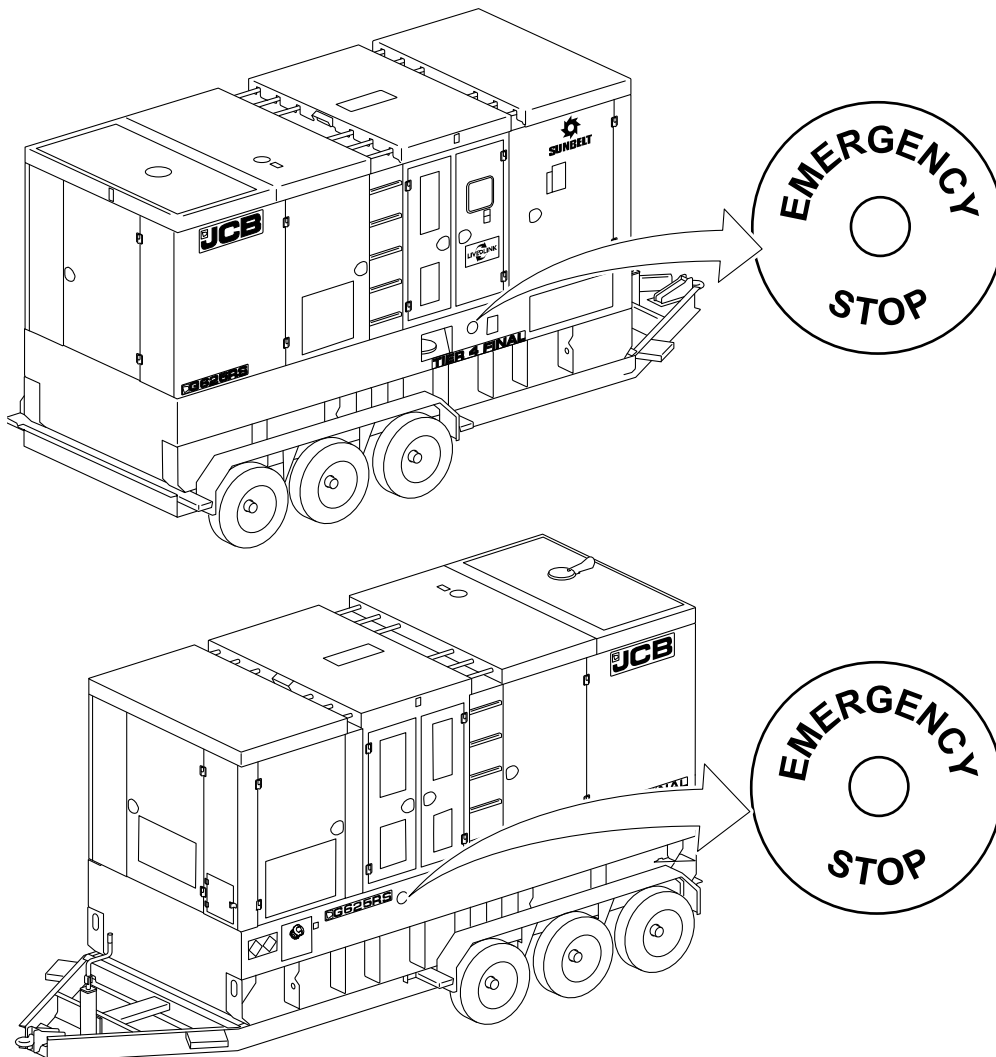

Stopping Procedure

Perform the procedure below to stop the generator:

1. Turn off all loads to the generator.
2. Press the 'stop' button once. The generator will stop after the specified cooling time.
Duration: 5min
 - 2.1. If 'stop' button is pressed again then generator will stop immediately.

Instruments

General

Figure 20.

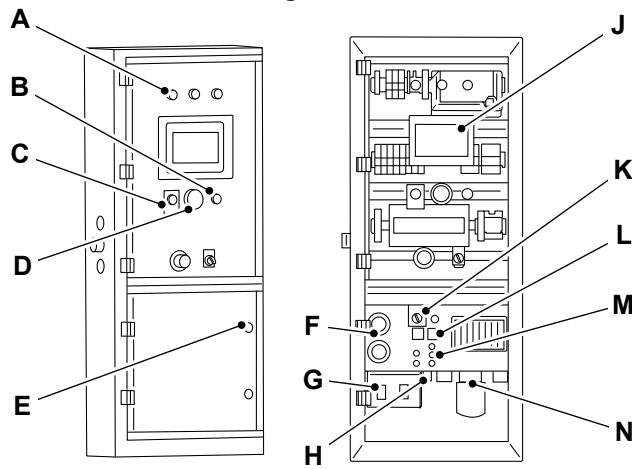

- A Auxiliary indicator lamps
- C BUS live indicator
- E Lockable door
- G GFCI 120V Small power
- J Voltage alarm
- L Digital synch connections
- N 3x50A Shore power - 120V/240V

- B Audible alarm
- D Audible alarm
- F Coolant heater and battery charger sockets
- H USB (Universal Serial Bus) port
- K End of line synch switches
- M Analog loadshare connection point

Figure 21.

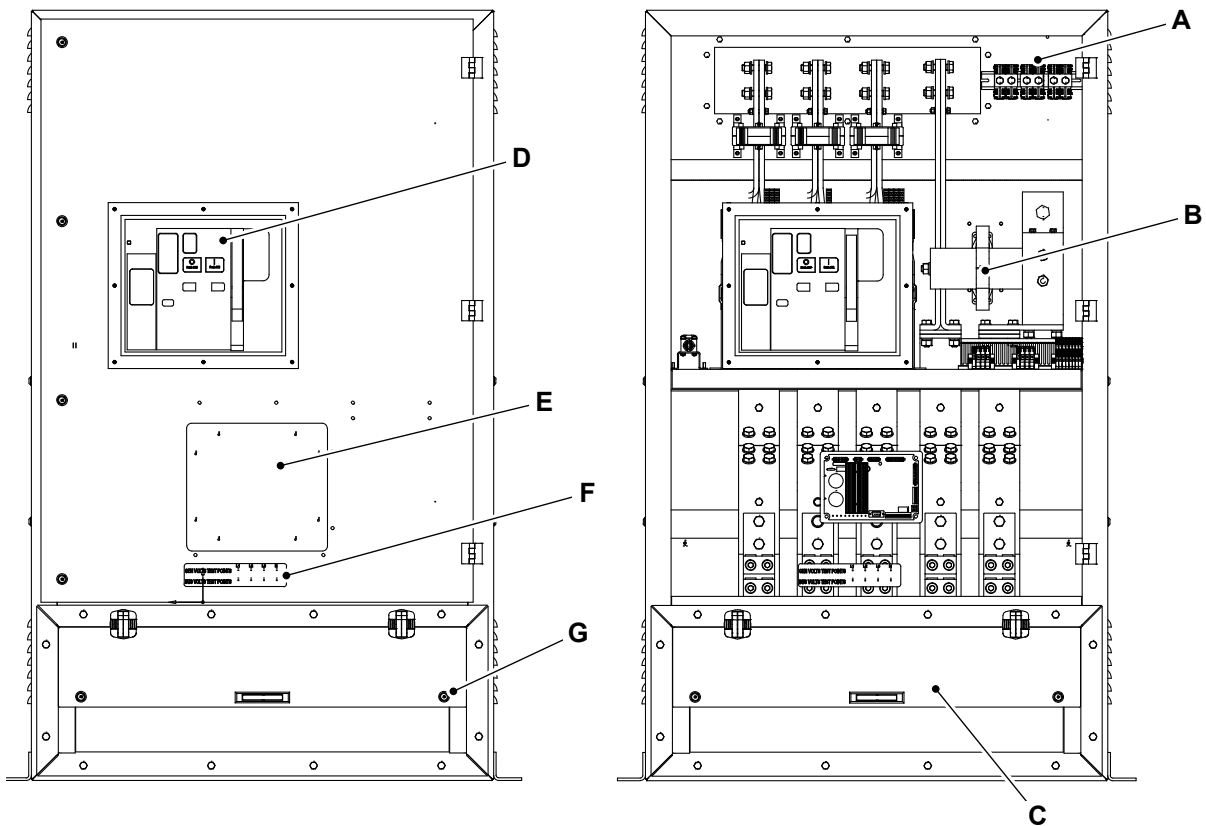

- A DIN rail terminal
- C Self latching cable cover with padlock
- E AVR (Alternator Voltage Regulator)

- B Toroid
- D Automatic circuit breaker
- F Test point

G Breaker safety trip switch

Control Panel

For: Control Panel DEIF AGC 4	Page 26
For: Control Panel DEIF TDU 107	Page 38
For: Control Panel 7310	Page 51
For: Control Panel 8610	Page 53

(For: Control Panel DEIF AGC 4)

Display push-buttons and LEDs

Push-button functions

The display unit holds a number of push-button functions which are described below:

Figure 22.

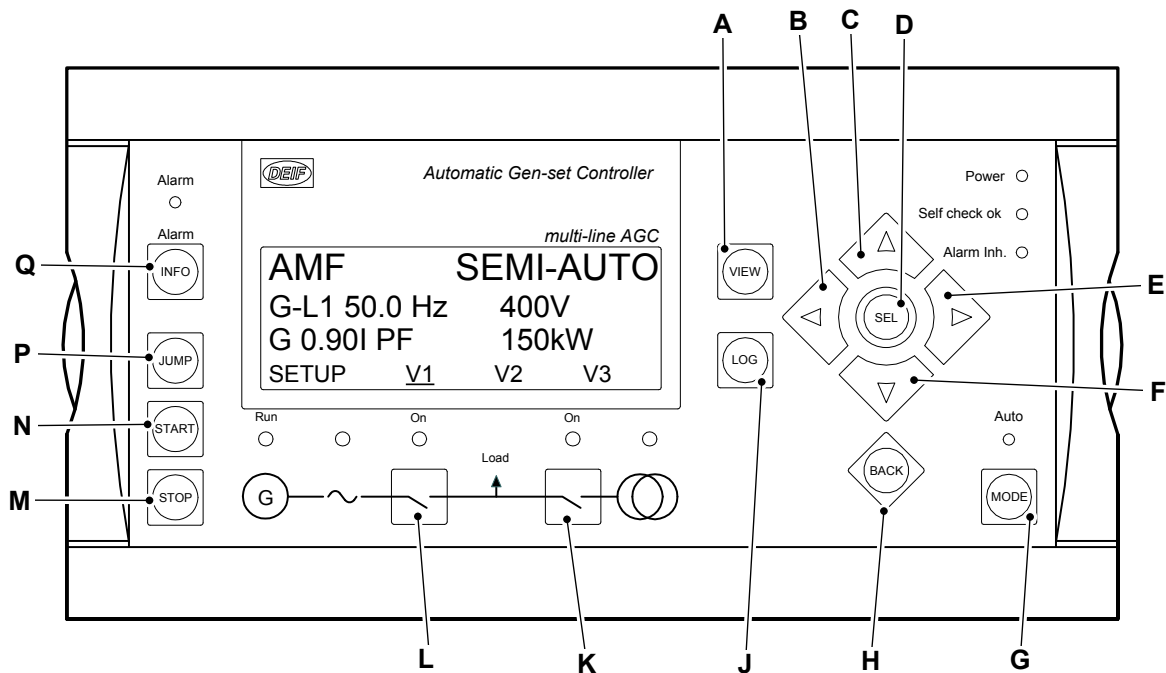

Table 5.

S. No.	Item	Function
A	VIEW	Shifts the first line displaying in the setup menus
B	Left	Scrolling left
C	Up	Scrolling up
D	SEL	Select the underscored entry
E	Right	Scrolling right
F	Down	Scrolling down
G	MODE	Mode selection
H	BACK	Jumps one step backward in the menu
J	LOG	Show the event and alarm list

S. No.	Item	Function
K		Manual activation of close breaker and open breaker sequence if "SEMI-AUTO" is selected
L		Manual activation of close breaker and open breaker sequence if "SEMI-AUTO" is selected
M	STOP	Stop the genset if "SEMI-AUTO" or "MANUAL" is selected
N	START	Start the genset if "SEMI-AUTO" or "MANUAL" is selected
P	JUMP	Enters a specific menu number selection
Q	INFO	Show the alarm list

LED functions

The display unit holds 10 LED (Light Emitting Diode) functions. The color is green or red or a combination in different situations. The display LEDs are indicating as follows:

Figure 23.

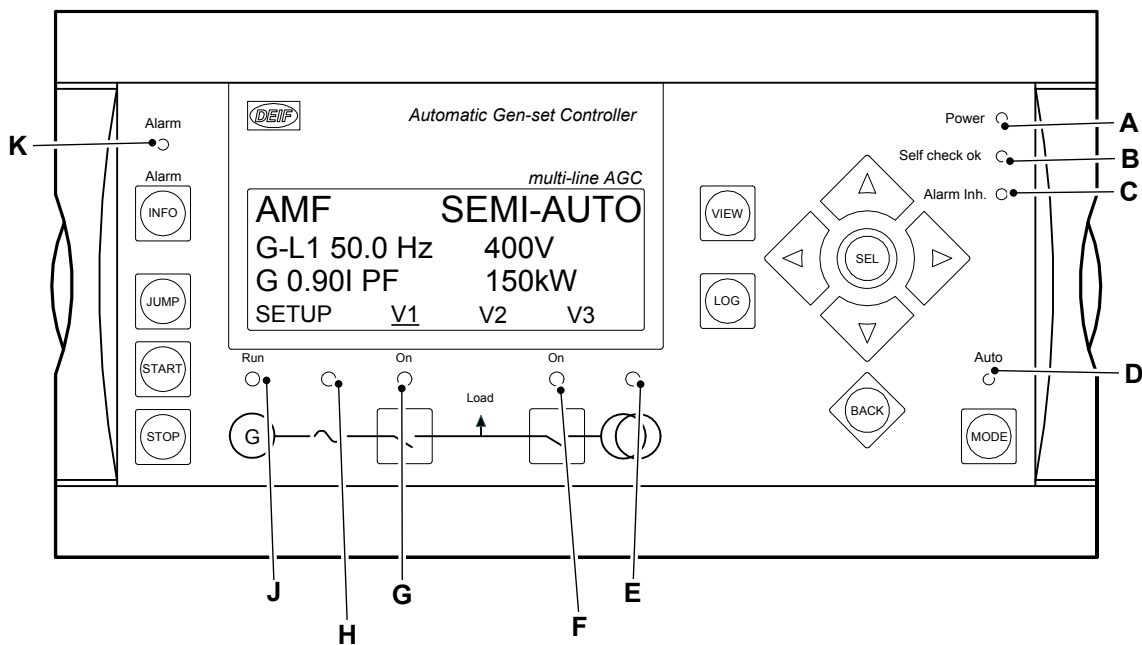

Table 6.

A	Auxiliary supply is switched on
B	Unit is OK
C	Alarm is enabled but inhibited
D	Automatic mode is selected
E	Green: mains is present and OK
	Red: mains failure
	Green flashing: mains returns during the "mains OK delay" time
F	Mains breaker is closed
G	Generator breaker is closed
H	Voltage/frequency is present and OK
J	Generator is running
K	LED flashing: unacknowledged alarms are present
	LED fixed: all alarms are acknowledged, but some are still present

Display and menu structure

General

This chapter deals with the display unit including the push-button and LED functions. In addition, the unit menu structure will be presented.

Display layouts for DEIF AGC-4

Figure 24. Engine and generator breaker control (island) (option Y1)

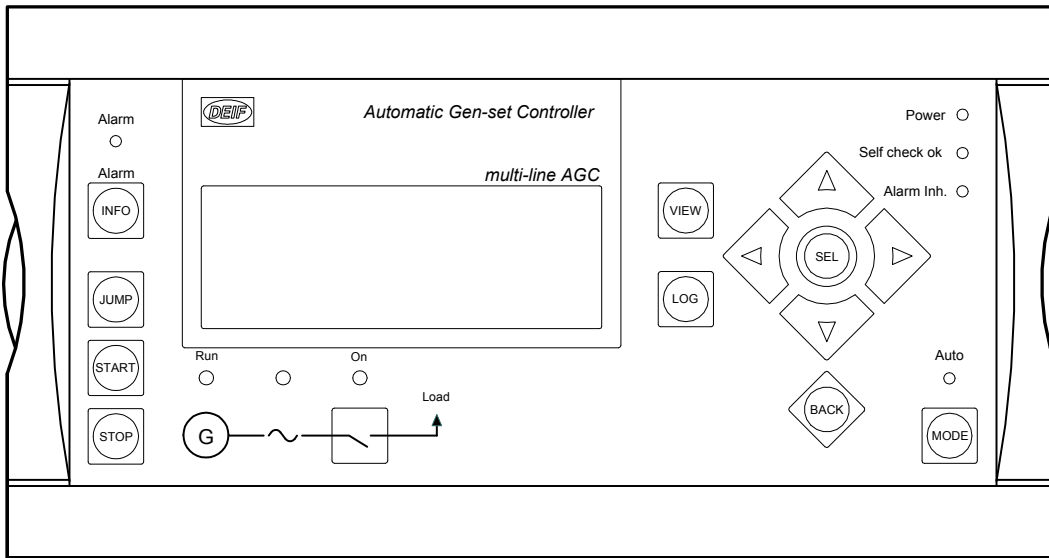

Figure 25. Generator breaker and mains breaker control (option Y3)

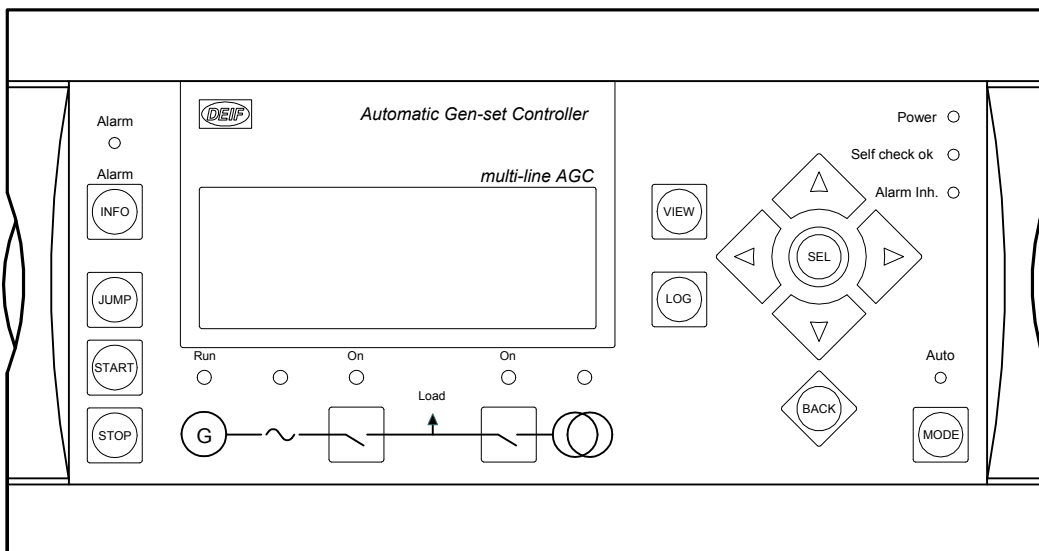

Figure 26. Tie breaker and mains breaker control (option Y4)

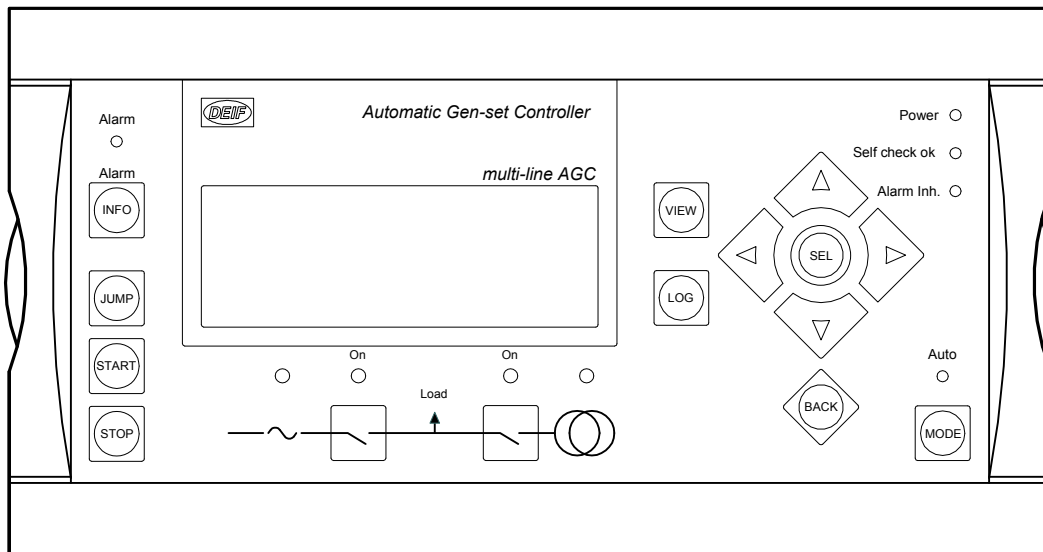
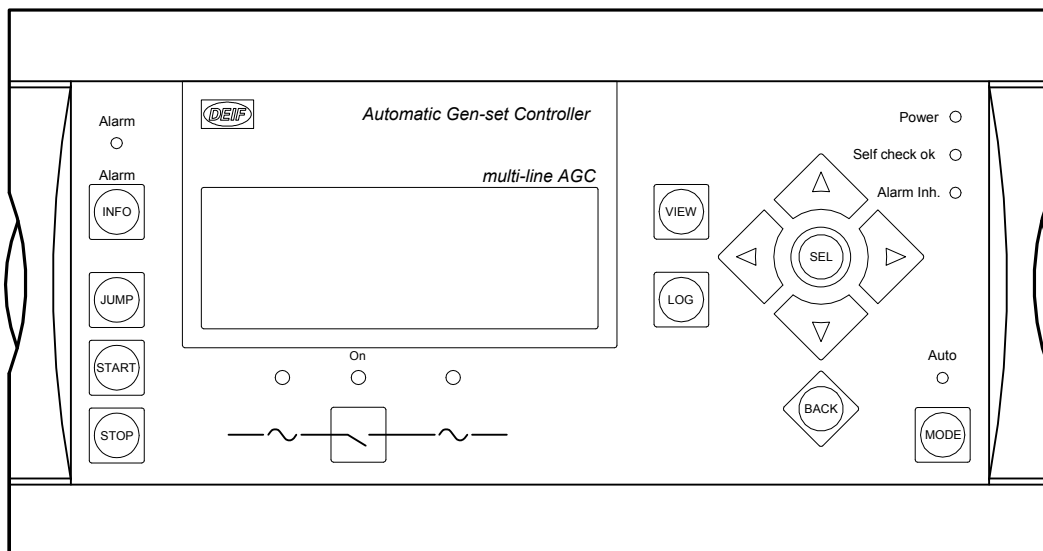

Figure 27. Bus tie breaker control (option Y5)



LCD display

The display is a backlit LED text display containing four lines with 20 characters in each line. There is no control of the display light intensity (no dimmer). Basically, all measured and calculated values can be read in the display. These may be selected via the PC utility software (USW).

Menu structure

The display includes two menu systems which can be used without password entry:

View menu system:

This is the commonly used menu system. 15 windows are configurable and can be entered by using the arrow push-buttons.

Setup menu system (not commonly used by the operator):

This menu system is used for setting up the unit, and if the operator needs detailed information that is not available in the view menu system.

Changing of parameter settings is password-protected.

Entry window

When the unit is powered up, an entry window appears. The entry window is the turning point in the menu structure and as such the gateway to the other menus. It can always be reached by pushing the BACK push-button three times.

Figure 28.

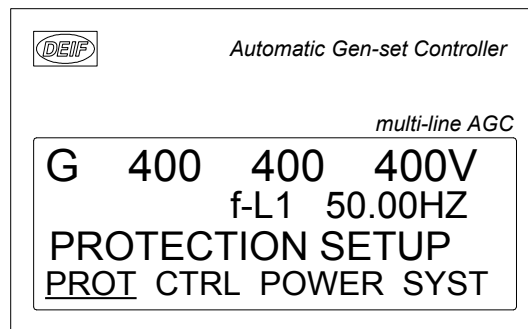

View menu

The view menus (V1, V2 and V3) are the daily use menus for the operator.

In the view menus, various measured values are on display.

Figure 29.

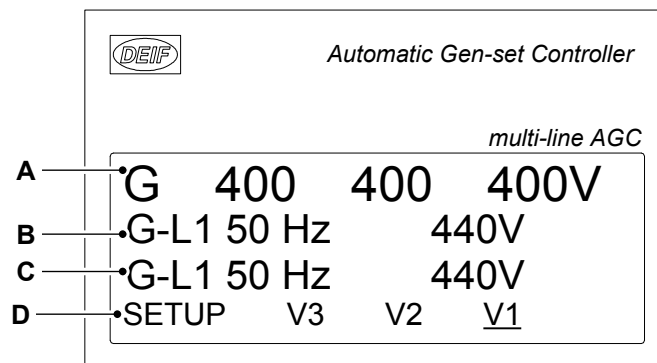

1. First display line: operational status or measurements
2. Second display line: measurements relating to operational status
3. Third display line: measurements relating to operational status
4. Fourth display line: selection of setup and view menus

View menu navigation

The readings etc. are all selected by moving the cursor (fourth display line (note the underscore of V1 in the drawing above - this is the cursor))

The cursor is moved using the Left and Right push-buttons on the right side of the display.

View window 1

Display of measured values according to the selections made during configuration.

V1 contains up to 15 different windows which can be selected using the Up and Down push-buttons located on the right hand side of the display.

Table 7.

Windows	V1
View 1	Manual selection with Up or Down push-buttons
View 2	
View 3	
View 4	
View 5	
View 6	
View 7	
View 8	
View 9	
View 10	
View 11	
View 12	
View 13	
View 14	
View 15	
View 16	
View 17	
View 18	
View 19	
View 20	

View window 2

Display of measured values according to the selections made during configuration.

Display V2 follows the selection in V1 as follows:

1. View 1: (Start prepare)
2. View 2: (Synchronizing)
3. View 3: (Ramp up/down)
4. View 4:
5. View 5: (Default (when none of the above are in operation))

Table 8.

Windows	V2	V3
View 1	Changes automatically between the five first views. ⁽¹⁾	Changes automatically between the five first views. ⁽¹⁾
View 2		
View 3		
	1. View 1 (Start prepare) ⁽¹⁾	1. View 1 (Start prepare) ⁽¹⁾
	2. View 2 (Sync.) ⁽¹⁾	2. View 2 (Sync.) ⁽¹⁾
	3. View 3 (Ramp up/down) ⁽¹⁾	3. View 3 (Ramp up/down) ⁽¹⁾
	4. View 4 ⁽¹⁾	4. View 4 ⁽¹⁾
	5. View 5 (Default) ⁽¹⁾	5. View 5 (Default) ⁽¹⁾

Windows	V2	V3
View 4	No manual selection.	No manual selection.
View 5	All three lines show measuring values.	Line 1 shows the text 1...5 (above). Line 2 and line 3 show measurements.

(1) The default window is automatically selected after the ramping up when the genset is in normal operation, e.g. fixed power mode.

View window 3

Display of measured values according to the selections made during configuration.

The V3 display changes with running modes:

First display line indicates running status of the unit. The messages shown in the table at the end of this chapter can be displayed.

Second and third display lines display measured values.

Fourth display line displays the selection line.

Display V3 follows the selection in V1 as follows:

1. View 1: (Start prepare)
2. View 2: (Synchronizing)
3. View 3: (Ramp up/down)
4. View 4:
5. View 5: (Default (when none of the above are in operation))

Table 9.

Windows	V2	V3
View 1	Changes automatically between the five first views. ⁽¹⁾ 1. View 1 (Start prepare) ⁽¹⁾ 2. View 2 (Sync.) ⁽¹⁾ 3. View 3 (Ramp up/down) ⁽¹⁾ 4. View 4 ⁽¹⁾ 5. View 5 (Default) ⁽¹⁾	Changes automatically between the five first views. ⁽¹⁾ 1. View 1 (Start prepare) ⁽¹⁾ 2. View 2 (Sync.) ⁽¹⁾ 3. View 3 (Ramp up/down) ⁽¹⁾ 4. View 4 ⁽¹⁾ 5. View 5 (Default) ⁽¹⁾
View 2		
View 3		
View 4	No manual selection.	No manual selection.
View 5	All three lines show measuring values.	Line 1 shows the text 1...5 (above). Line 2 and line 3 show measurements.

(1) The default window is automatically selected after the ramping up when the genset is in normal operation, e.g. fixed power mode.

Status line text

This table explains the different messages.

Table 10.

Status text	condition	Comment
BLOCK	Block mode is activated	
SIMPLE TEST	Test mode is activated	

Status text	condition	Comment
LOAD TEST		
FULL TEST		
SIMPLE TEST ###.#min	Test mode activated and test timer counting down	
LOAD TEST ###.#min		
FULL TEST ###.#min		
ISLAND MAN	Genset stopped or running and no other action taking place	
ISLAND SEMI		
READY ISLAND AUTO	Genset stopped in Automatic	
ISLAND ACTIVE	Genset running in Automatic	
AMF MAN	Genset stopped or running and no other action taking place	
AMF SEMI		
READY AMF AUTO	Genset stopped in Automatic	
AMF ACTIVE	Genset running in Automatic	
FIXED POWER MAN	Genset stopped or running and no other action taking place	
FIXED POWER SEMI		
READY FIXED P AUTO	Genset stopped in Automatic	
FIXED POWER ACTIVE	Genset running in Automatic	
PEAK SHAVING MAN	Genset stopped or running and no other action taking place	
PEAK SHAVING SEMI		
READY PEAK SHAV AUTO	Genset stopped in Automatic	
PEAK SHAVING ACTIVE	Genset running in Automatic	
LOAD TAKEOVER MAN	Genset stopped or running and no other action taking place	
LOAD TAKEOVER SEMI		
READY LTO AUTO	Genset stopped in Automatic	
LTO ACTIVE	Genset running in Automatic	
MAINS P EXPORT MAN	Genset stopped or running and no other action taking place	
MAINS P EXPORT SEMI		
READY MPE AUTO	Genset stopped in Automatic	
MPE ACTIVE	Genset running in mains power export mode	
DG BLOCKED FOR START	Generator stopped and active alarm(s) on the generator	
GB ON BLOCKED	Generator running, GB open and an active "Trip GB" alarm	
SHUTDOWN OVERRIDE	The configurable input is active	
ACCESS LOCK	The configurable input is activated, and the operator tries to activate one of the blocked keys	
GB TRIP EXTERNALLY	Some external equipment has tripped the breaker	An external trip is logged in the event log
MB TRIP EXTERNALLY	Some external equipment has tripped the breaker	An external trip is logged in the event log
IDLE RUN	The "Idle run" function is active. The genset will not stop, until a timer has expired	
IDLE RUN ###.#min	The timer in the "Idle run" function is active	
COMPENSATION FREQ.	Compensation is active	The frequency is not at the nominal setting
Aux. test ##.#V #####s	Battery test activated	

Status text	condition	Comment
DELOAD	Decreasing the load of the genset in order to open the breaker	
START DG(s) IN ###s	The start genset setpoint is exceeded	
STOP DG(s) IN ###s	The stop genset setpoint is exceeded	
START PREPARE	The start prepare relay is activated	
START RELAY ON	The start relay is activated	
START RELAY OFF	The start relay is deactivated during the start sequence	
MAINS FAILURE	Mains failure and mains failure timer expired	
MAINS FAILURE IN ###s	Frequency or voltage measurement is outside the limits	The timer shown is the mains failure delay. Text in mains units
MAINS U OK DEL #####s	Mains voltage is OK after a mains failure	The timer shown is the mains OK delay
MAINS f OK DEL #####s	Mains frequency is OK after a mains failure	The timer shown is the mains OK delay
Hz/V OK IN ###s	The voltage and frequency on the genset is OK	When the timer runs out it is allowed to operate the generator breaker
COOLING DOWN ###s	Cooling down period is activated	
GEN-SET STOPPING	This info is shown when cool down has finished	
EXT. STOP TIME ###s		
PROGRAMING LANGUAGE	This info is shown if the language file is downloaded from the PC utility software	
TOO SLOW 00<-----	Generator running too slow during synchronizing	
-----> 00 TOO FAST	Generator running too fast during synchronizing	
EXT. START ORDER	A planned AMF sequence is activated	There is no failure on the mains during this sequence
SELECT GEN-SET MODE	Power management has been deactivated and no other genset mode has been selected	Option G5 must be available
QUICK SETUP ERROR	Quick setup of the application failed	
MOUNT CAN CONNECTOR	Connect the power management CAN line	
ADAPT IN PROGRESS	The AGC is receiving the application that it has just been connected to	
SETUP IN PROGRESS	The new AGC is being added to the existing application	
SETUP COMPLETED	Successful update of the application in all AGC units	
REMOVE CAN CONNECTOR	Remove the power management CAN lines	
RAMP TO #####kW	The power ramp is ramping in steps, and the next step that will be reached after the timer has expired will be displayed	

Status text	condition	Comment
DERATED TO #####kW	Displays the ramp down setpoint	
PREPARING ETHERNET	Initializing the Modbus TCP/IP	
PREPARING ENGINE IF	Preparing engine IF	
PROGRAMING MLOGIC		

Texts only related to Power Management (option G5)

Table 11.

Status text	Condition	Comment
DG unit		
BLACKOUT ENABLE	This information is shown if a CAN failure is present in a power management application	
UNIT STANDBY	If redundant mains units are present, this message is shown on the redundant unit	
DELOADING BTB XX	DG units are load sharing asymmetrically to deload BTB XX dividing two sections in an application	
BTB XX DIVIDING SEC.	BTB XX is dividing two sections in an application	
SYNCHRONIZING TB XX	TB XX is synchronizing	
SYNCHRONIZING MB XX	MB XX is synchronizing	
SYNCHRONIZING BTB XX	BTB XX is synchronizing	
Mains unit		
UNIT STANDBY	If redundant mains units are present, this message is shown on the redundant unit	
TB TRIP EXTERNALLY	Some external equipment has tripped the breaker	An external trip is logged in the event log
BTB unit		
DIVIDING SECTION	A BTB unit is dividing two sections in an application	
READY AUTO OPERATION	BTB unit in Automatic and ready for breaker operation (no active "BTB trip" alarm)	
SEMI OPERATION	BTB unit in Semi	
AUTO OPERATION	BTB unit in Automatic, but not ready for breaker operation (active "BTB trip" alarm)	
BLOCKED FOR CLOSING	Last open BTB in a ring bus	
BTB TRIP EXTERNALLY	Some external equipment has tripped the breaker	An external trip is logged in the event log
All units		
BROADCASTING APPL. #	Broadcast of an application through the CAN line	Broadcasts one of the four applications from one unit to the other AGCs in the power management system
RECEIVING APPL. #	AGC receiving an application	
BROADCAST COMPLETED	Successful broadcast of an application	
RECEIVE COMPLETED	Application received successfully	

Status text	Condition	Comment
BROADCAST ABORTED	Broadcast terminated	
RECEIVE ERROR	Application is not received correctly	

View menu example

The following is an example of a configured view menu system. In this example, four of 15 windows have been configured in view 1.

Figure 30.

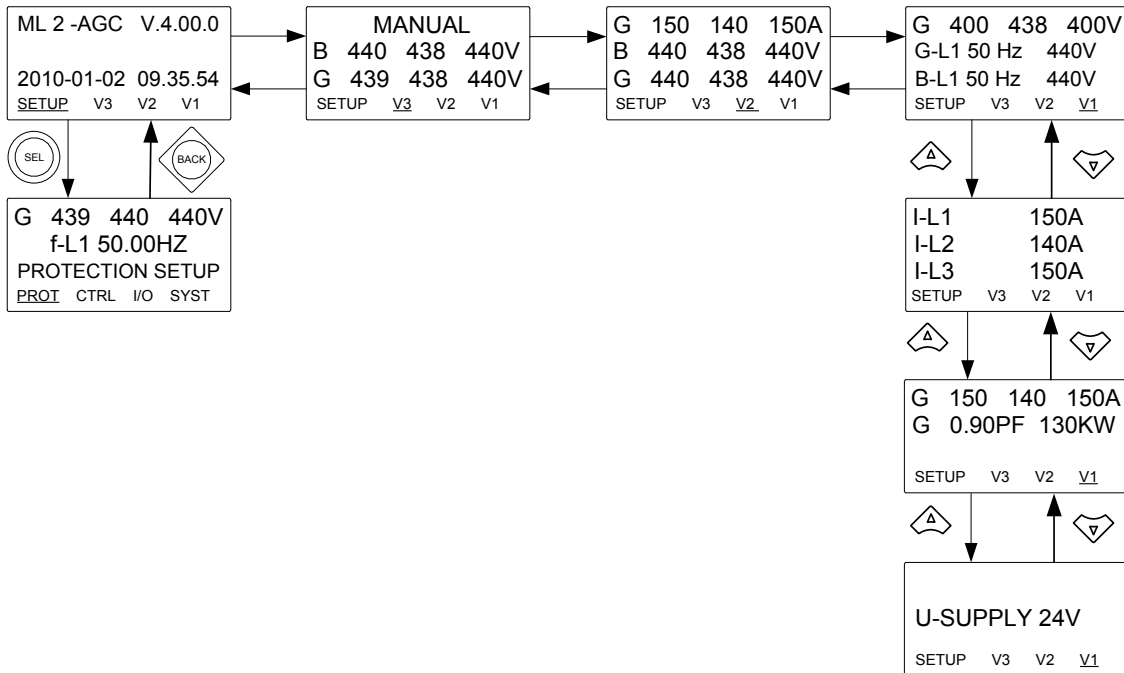

Mode menu

If the MODE push-button is pushed, a selection of possible running modes appears in the fourth display line.

Using the Left and Right push-buttons moves the cursor, and the appropriate mode can be selected by pressing the SEL button:

Table 12.

Mode	Description
SEMI	The display push-buttons (START, STOP, GB ON, GB OFF) are active and can be used by the operator. The regulators are also active, i.e. the speed control will bring the generator to nominal speed upon start. When pushing a breaker button for closing, the DEIF AGC will synchronize (if allowed) the breaker. When the breaker closes, the controls stop.
TEST	The unit will start the generator, carry out the test sequence (predefined time period) and stop the generator again. Subsequently, the generator will return to AUTO or SEMI-AUTO mode. The mains breaker will remain closed, and the generator breaker will remain open. NOTE: The test running can be: Simple test: Starting the genset without closing the GB; Load test: Parallel to the mains and take load to a predefined value; Full test: Transfer the load to the genset and open the MB.

Mode	Description
AUTO	<p>The unit will automatically carry out the control type selected (AMF, fixed power, etc.).</p> <p>The display control push-buttons (START, STOP, GB ON, GB OFF) are disabled.</p> <p>If the selected running mode is fixed power, mains power export, load takeover or island, timer start/stop (week watch) or binary input, then start/stop can be used.</p>
MAN	<p>The display push-buttons (START, STOP) are active and can be used by the operator.</p> <p>The regulators are not active, i.e. speed (and voltage) control has to take place using binary inputs for UP and DOWN control.</p> <p>The breakers will be able to open or close at any time. A synchronization check will always be performed to ensure safe closing of the breakers.</p>
BLOCK	<p>The unit will not be able to start. BLOCK mode can be selected during standstill and the password is needed to exit BLOCK mode. If the BLOCK mode is selected while the genset is running, the mode will have no effect until the genset is stopped. To select another mode after the BLOCK mode, the password must be entered.</p>

To return to the other display functions from MODE selection, press the BACK push-button.

Alarm handling and log list

Alarm handling

When an alarm occurs, the unit will automatically go to the alarm list for display of the alarm.

If reading of the alarms is not desired, use the BACK push-button to exit the alarm list.

If you decide to enter the alarm list later, use the INFO push-button to jump directly to the alarm list reading.

The alarm list contains both acknowledged and unacknowledged alarms provided that they are still active (i.e. the alarm condition is still present). Once an alarm is acknowledged and the condition has disappeared, the alarm will no longer be displayed in the Alarm list.

This means that if there are no alarms, the alarm list will be empty.

Figure 31.

G	0	0	0V
1230 Gen low-volt 1			
UN-ACK 1 2 Alarm(s)			
<u>ACK</u>		FIRST	LAST

This display example indicates an unacknowledged alarm. The display can show only one alarm at a time. Therefore, all other alarms are hidden.

To see the other alarms, use the Up and Down push-buttons to scroll in the display.

To acknowledge an alarm, place the cursor (underscore) under "ACK" and then press SEL.

To jump to the first (oldest) or the last (most recent) alarm, place the cursor under the selection (FIRST or LAST) and press SEL.

Log list

The log is divided into three different lists:

1. Events
2. Alarms
3. Battery test

The log list contains up to 150 events, the alarm list contains up to 30 historical alarms and the battery test list contains up to 52 historical battery tests.

An event is e.g. closing of breaker and starting of engine. An alarm is e.g. overcurrent or high cooling water temperature. A battery test is e.g. test OK or test failed.

To enter the log list:

1. Press LOG.
2. Select the list which is needed by using the Left and Right push-buttons and press the SEL push-button.
3. To scroll up and down in the list, use the Up and Down push-buttons.

It is also possible to go to the first (oldest) logging or the last (most recent) logging by placing the cursor (underscore) under the selection (move the cursor using the Left and Right push-buttons) and press the SEL push-button.

(For: Control Panel DEIF TDU 107)

Controller Overview

General Description

The Touch Display Unit, TDU 107, is a touch screen solution for controlling either a DEIF AGC-4 genset or mains controller using the Ethernet port.

The display gives user-friendly touch screen control, visualization, and graphic displays from the AGC-4 controller.

Simply operate the controller and access any feature by touching the screen.

Menus

The menu pages give you access to the features and to other menus.

Figure 32.

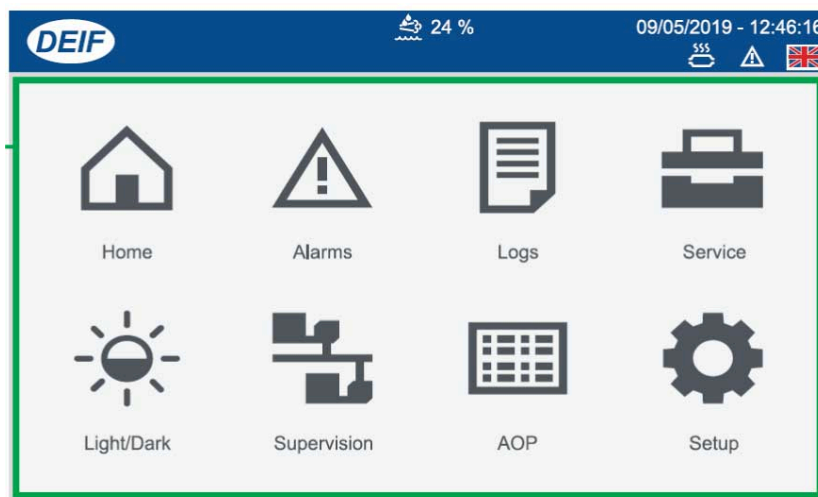

Return (back) navigation

Some displays allow you to go back to the previous feature or menu.

Use Return to go back to a previous menu or display.

Software Update Using USB

Before You Begin

You can update your TDU 107 with the latest software version by using the USB port.

To update your TDU 107, you need the following:

Required tools:

USB Memory Device (FAT32)

- To import/export the file(s) to your PC.
- Must be formatted for FAT32 file system to be recognized by the TDU 107.

PC

- To download the software package file.
- To copy the software package file to the USB memory device.

Download and Update Software

1. Visit the DEIF homepage <https://www.deif.com/products/tdu-107#software> to download the latest version.
 - 1.1. Software is available for both TDU 107 Core and TDU 107 Extended. Download the software for your version of the TDU 107.
2. Follow the instructions in the DEIF email to complete the software download.
3. Copy the update file across to your USB memory device without renaming the file.
4. Insert the USB memory device in the USB port on the TDU 107.
5. You are then guided through the rest of the installation on the display.

NOTE: The software package is provided as a zipped archive (.zip) file. Do not rename or unzip this file. The file must be copied to your USB memory device with the same file name, and as a ZIP file (.zip) for the update to be recognized by the TDU 107.

Front Overview

Figure 33.

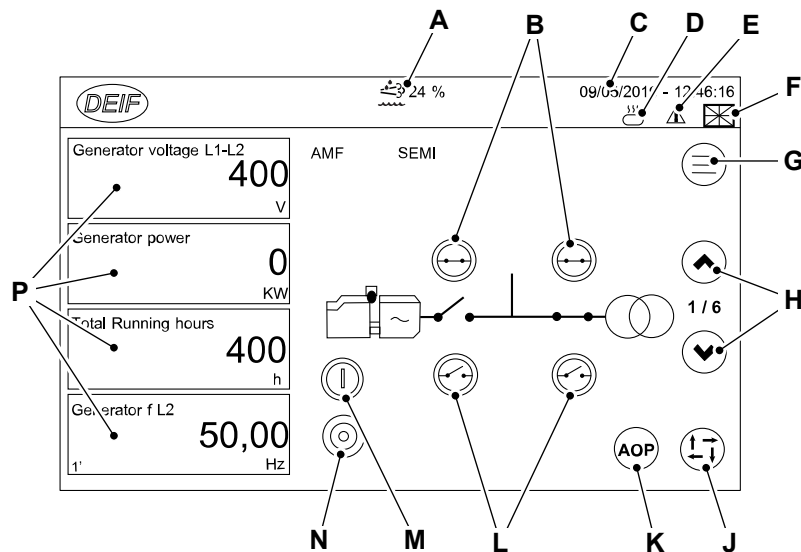

Table 13.

Sr. No.	Item	Function
A	DEF (Diesel Exhaust Fluid) percentage	Shows the percentage of DEF
B	Breaker control	Closes the breaker
C	Date and Time	Shows the controller Date and Time
D	EAT (Exhaust After Treatment) dashboard	Opens EAT dashboard (shortcut)
E	Alarm	Opens alarms (shortcut)
F	Language	Opens language (shortcut)
G	Menu	Opens the menu page
H	Scroll page	Scroll Up or Down
J	Mode change	Manual/SEMI/AUTO/TEST modes
K	AOP	Opens Additional Operator Panel (shortcut)
L	Breaker control	Opens breaker
M	Generator control	Starts generator
N	Generator control	Stops generator
P	Instrument values	Shows instrument values

Control Panel

Operates the system, can include mode change, open or close breakers, and start or stop the genset. It also provides instrument values, which can be selected by the operator.

Instrument selection

Changes the displayed instrument value shown on the Control panel page.

Figure 34.

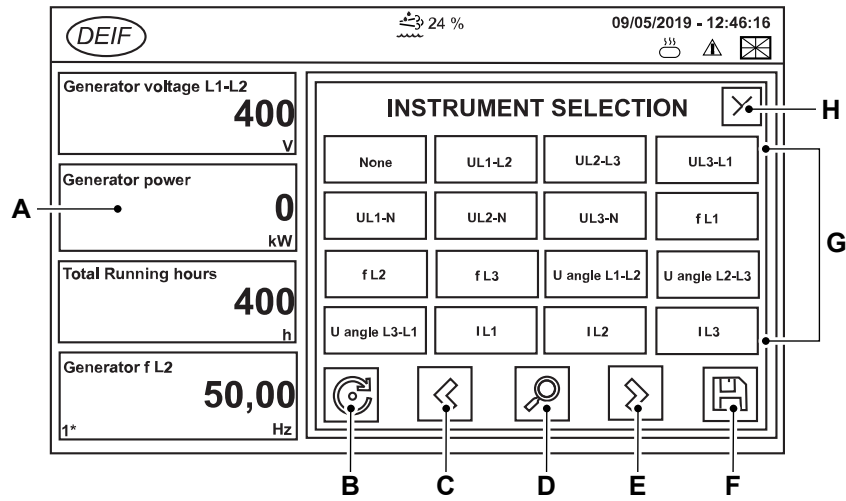

- A Instrument value to be changed
- C Scroll page left
- E Scroll page right
- G Instrument values

- B Refresh
- D Search
- F Save
- H Cancel

Supervision

Views the state of the system in real-time.

Figure 35.

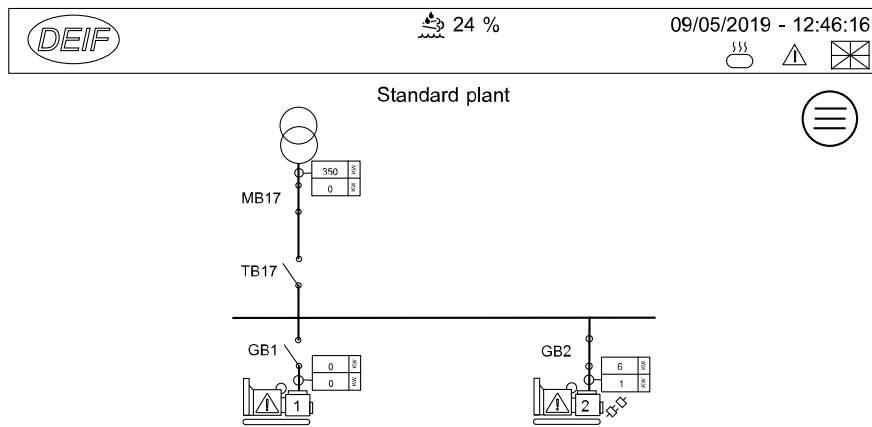

Controller Settings

Views or configures the controller parameter settings.

Figure 36.

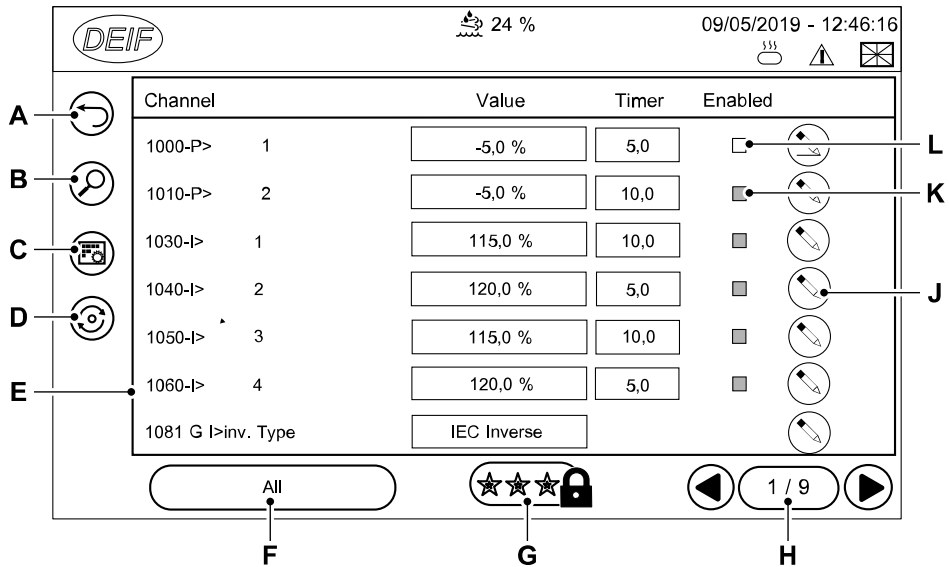

Table 14.

Sr. No.	Item	Function
A	Return	Return to previous display
B	Search	Opens search keyboard
C	Filter groups	Opens groups of parameters
D	Refresh	Reloads the list
E	Controller settings list	Scroll settings up or down on this page
F	Clear filter group	Clears the filter group (if used)
G	Filter by password level	Filters the list by minimum password level
H	Scroll page	Scroll the page left or right
J	Edit	Edits the settings
K	Enabled Status	Not enabled
L	Enabled Status	Enabled

Edit Settings

Edits the controller setting that was selected.

Figure 37.

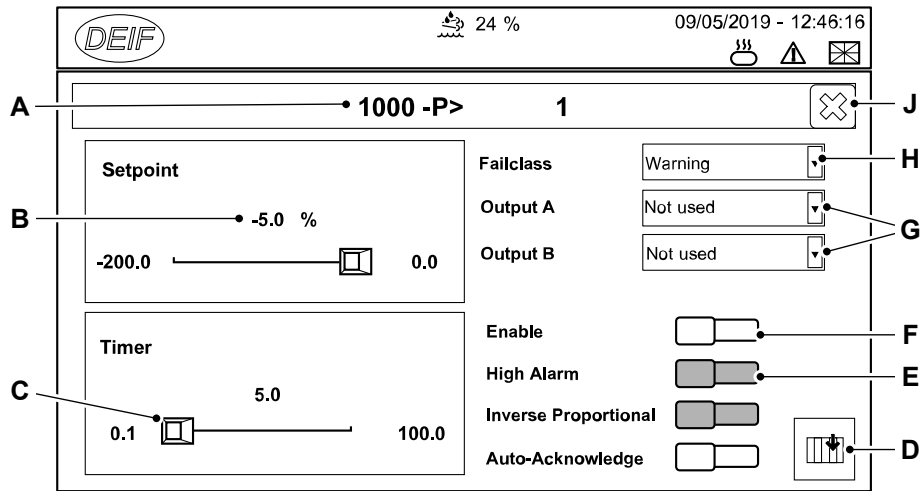

Table 15.

Sr. No.	Item	Function
A	Setting	Shows the name of the setting
B	Value	Shows or edits the value of the setting
C	Value (scroll)	Scrolls left or right to increase or decrease the value
D	Write	Writes the settings to the controller
E	Settings	Cannot be changed
F	Settings	Settings enabled or disabled
G	Output	Selects an output terminal
H	Failclass	Selects a failclass
J	Cancel	Cancels the changes

Filter Groups

Lists the filter groups you can use to filter the controller settings page.

Figure 38.

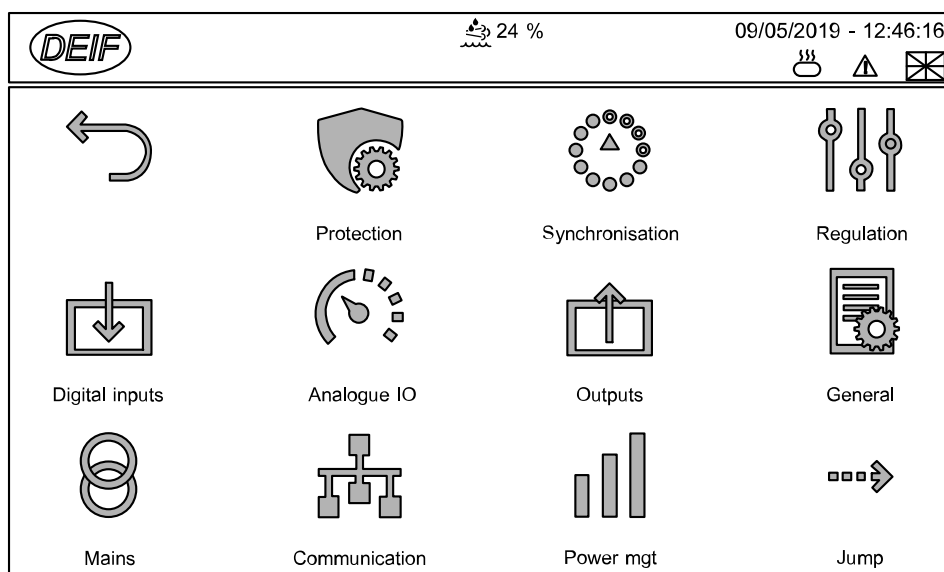

Alarms

Views or acknowledges any alarm created in the system.

Figure 39.

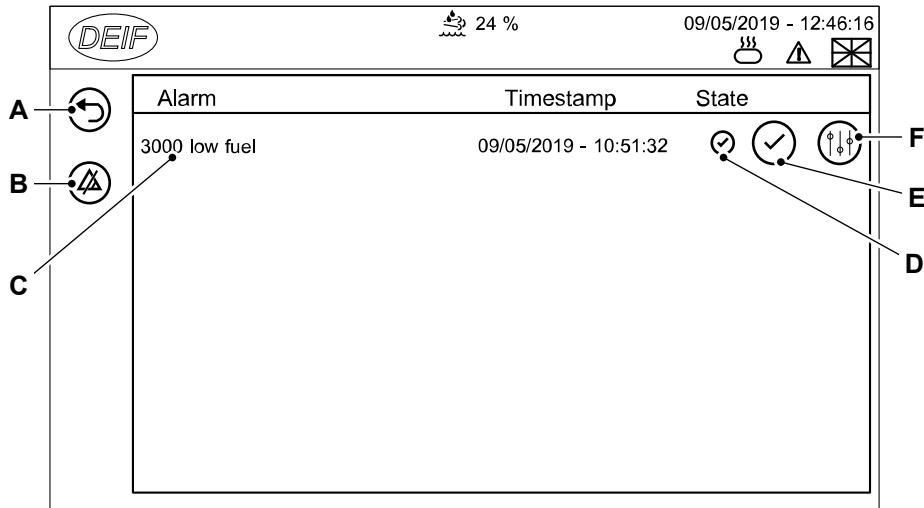

Table 16.

Sr. No.		
A	Back	Returns to previous display.
B	Acknowledge all alarms	Acknowledges all unacknowledged alarms.
C	Alarm list	Scrolls the alarms list up or down.
D	Alarm state	Shows the state of the alarm acknowledged or unacknowledged.
E	Acknowledge	Acknowledges alarm.
F	Alarm settings	Opens the alarm configuration.

Alarms Pop-up

New alarms activated in the system are shown on the alarms pop-up at the top of the display.

Figure 40.

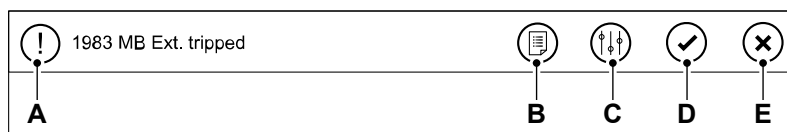

Table 17.

Sr. No.	Item	Function
A	Alarm	Shows the activated alarm.
B	Alarms list	Opens the alarms list (shortcut).
C	Alarm settings	Opens the alarm settings (shortcut).
D	Acknowledge	Acknowledges the alarm (shortcut).
E	Cancel	Cancel the pop up message.

Logs

Shows the list of all recorded events or alarms created in the system. You can also filter, merge, or view further details on the events.

Figure 41.

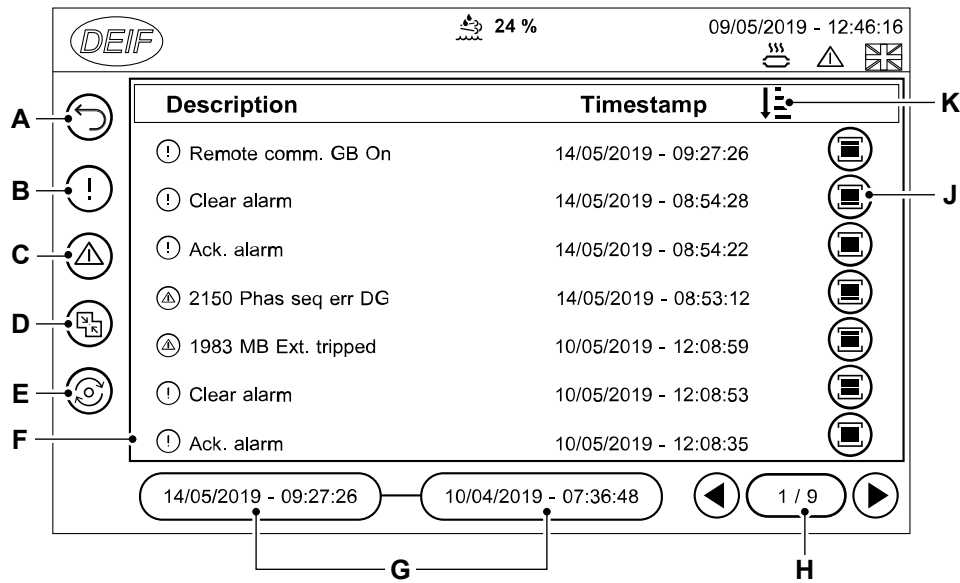

Table 18.

Sr. No.	Item	Function
A	Return	Returns to previous display.
B	Filter	Filters the list by showing alarms only.
C	Filter	Filters the list by showing events only.
D	Merge list	Merges the list to show both alarms and events.
E	Refresh	Refreshes the log list.
F	Log list	Scrolls the log list up or down.
G	Page range	Shows the date range of the list page shown.
H	Scroll page	Scroll the page left or right.
J	Event details	Shows the event details.
K	Sort page	Sorts the page in ascending or descending order.

Exhaust After-Treatment Dashboard (Tier4)

Shows information about the EAT system.

Figure 42.

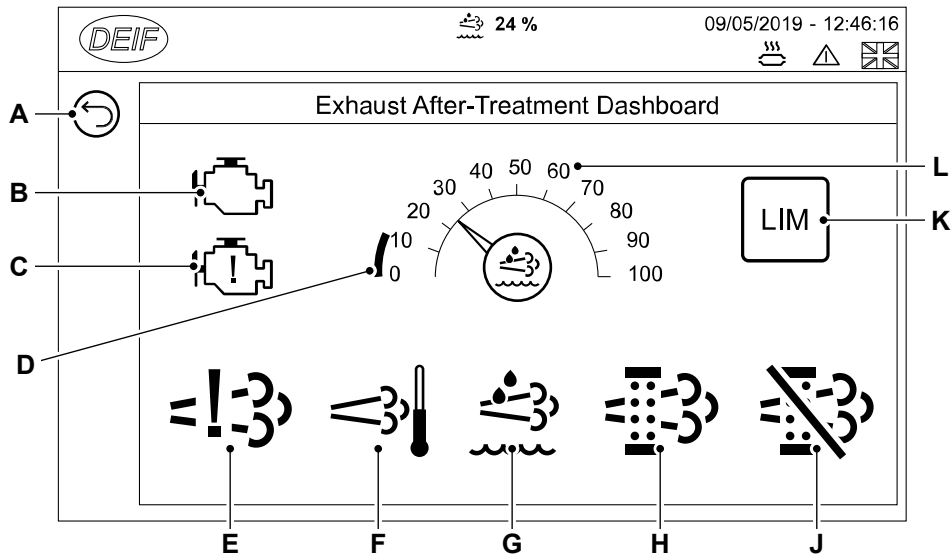

Table 19.

Sr. No.	Item	Function
A	Return	Returns to previous display.
B	Engine interface status	Shows an engine warning.
C	Engine interface status	Shows an engine shutdown.
D	Minimum DEF % level	Shows the minimum low level for the DEF.
E	Engine emission system failure	Shows an emission failure or malfunction.
F	High temperature - regeneration	Shows a high temperature and regeneration is in process.
G	DEF	Shows the level is too low.
H	DPF (Diesel Particulate Filter)	Shows that a regeneration is needed.
J	DPF inhibit	Shows that regeneration is inhibited.
K	LIM	Limit lamp.
L	Minimum DEF % level	Shows the level (%) of the DEF.

Alternator Curve

Views or configures the safe operation limits for the alternator.

Figure 43.

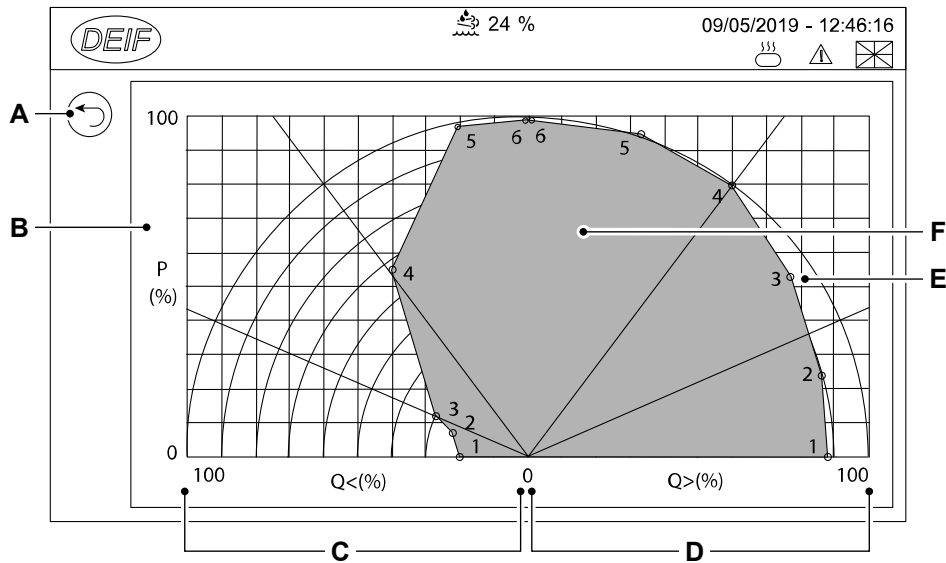

Table 20.

Sr. No.	Item	Function
A	Return	Returns to previous display.
B	Alternator curve	Shows the safe operation limits for the alternator.
C	Import (leading)	Opens the capacitive Q< configuration.
D	Export (lagging)	Opens the inductive Q> configuration.
E	Setting point	Shows the numbered setting points.
F	Actual working points	Shows the gensets actual working point.

Additional Operator Panel

Additional Operator Panels (AOPs) provide you with LED indication and button actions. You can configure the LED or button labels directly on the display, but the functionality behind them must be configured in your M-logic project on the utility software.

Figure 44.

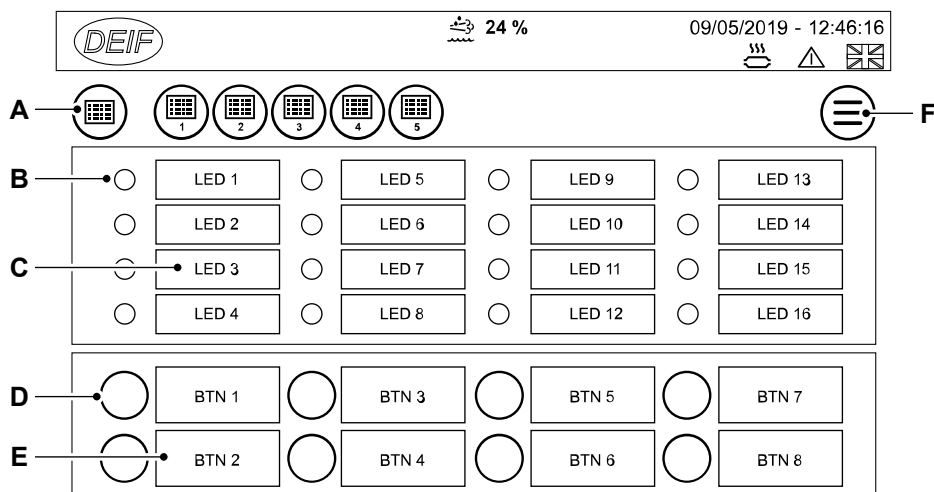

Table 21.

Sr. No.	Item	Function
A	Panel selection	Tap to select the panel to display.
B	LED status	Shows the LED status from the M-logic project conditions. ⁽²⁾
C	LED name	Edits the LED name. ⁽¹⁾
D	Button	Operated the button if configured.
E	Button name	Edits the button name. ⁽¹⁾
F	Menu	Opens the menu page.

(1) LED name and button name are saved locally on the TDU 107.

(2) The logic conditions must be configured in your M-logic project for the LED status and buttons to work.

Language

Selects an active language for the display.

Figure 45.

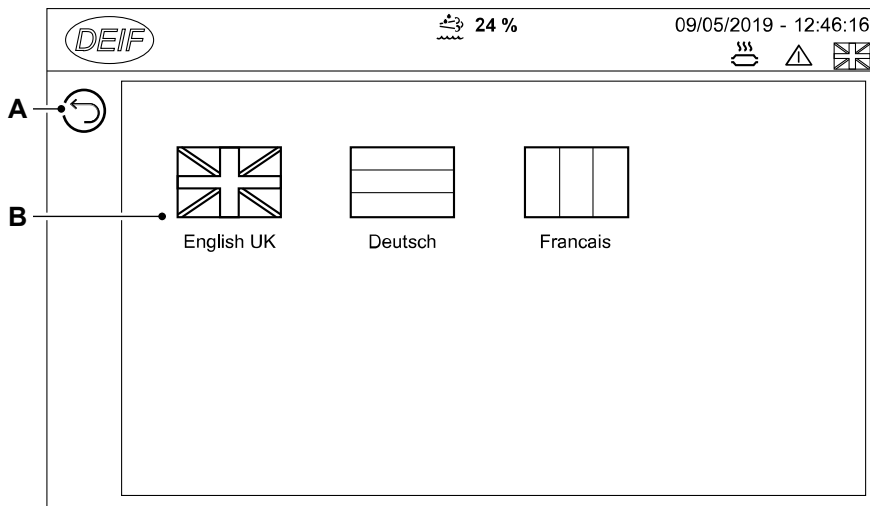

Table 22.

Sr. No.	Item	Function
A	Return	Return to previous display.
B	Languages ⁽¹⁾	Shows the available active languages.

(1) The actual languages shown must be both installed and active to be listed for selection.

User Permissions

Password Levels

Figure 46.

Symbol	Password level	Symbol	Password level
or	No login required	or	Level 1 - Customer
or	Level 2 - Service	or	Level 3 - Master

User Permissions

Features of the display can be restricted to the AGC-4 password levels.

Figure 47.

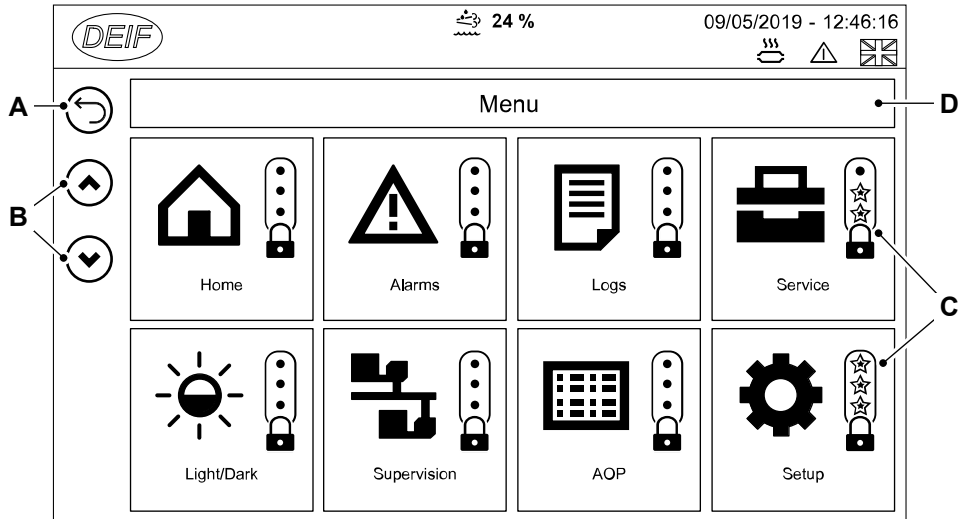

Table 23.

Sr. No.	Item	Description
A	Return	Returns to previous display.
B	Scroll page	Scrolls page up or down.
C	Feature permissions	Toggles through the password levels.
D	Page	Shows the page group name.

Display Configuration

View or configures the display settings.

Figure 48.

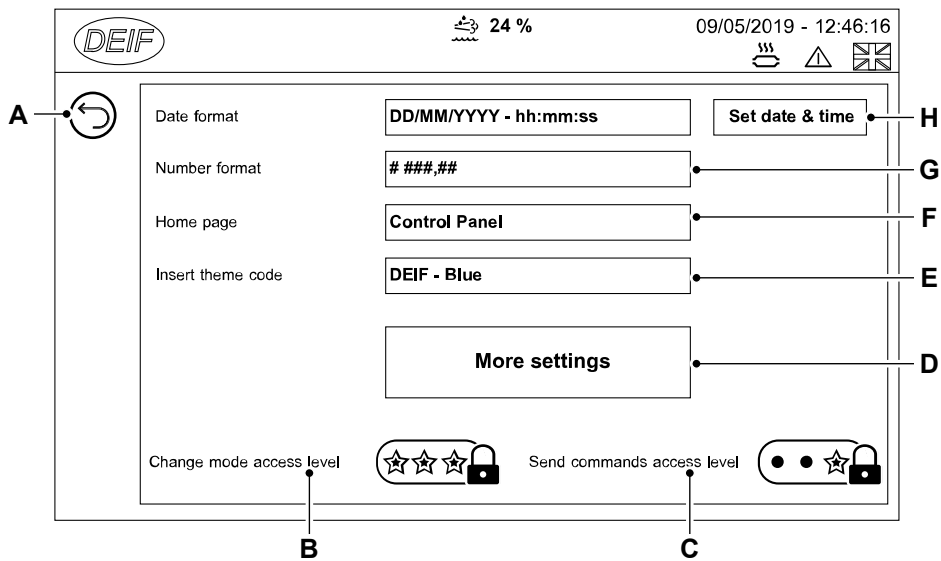

Table 24.

Sr. No.	Item	Function
A	Return	Returns to previous display
B	Change mode access level	Shows the minimum access level required to change operation mode.
C	Send commands access level	Shows the minimum access level required to send commands.
D	More settings	Opens the more settings page.
E	Theme code	Edits the name of the theme code.
F	Home page default	Selects the default to show on the home page.
G	Number format	Selects the format for the numbers shown.
H	Date and time	Shows the date and time format.

More Settings

Figure 49.

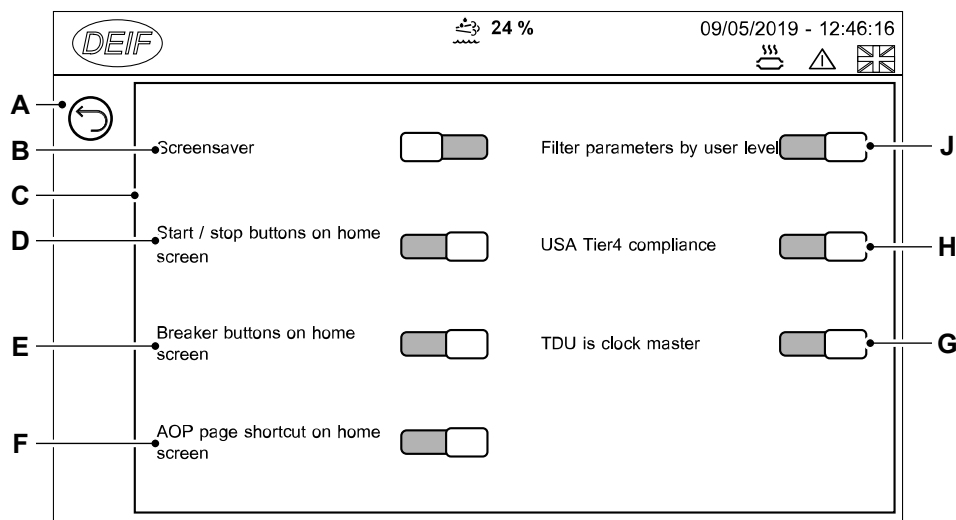

Table 25.

Sr. No.	Item	Description
A	Return	Returns to previous display.
B	Screen saver	Enables or disables the screen saver.
C	Settings	Toggles on or off additional settings.
D	Start or stop buttons	Shows or hides the start or stop buttons on the home page.
E	Breaker buttons	Shows or hides the breaker buttons on the home page.
F	AOP shortcut	Shows or hides the start or stop buttons on the home page.
G	TDU clock master	Enables or disables the TDU as the master clock for the system.
H	Tier 4 compliance	Enable this to automatically display the EAT Dashboard if an alarm becomes active.
J	Filer parameters	Enables or disables the filtering of parameters by minimum password level.

Language Management

Manages the display translations available on the display. Only Active languages can be used on the display.

Figure 50.

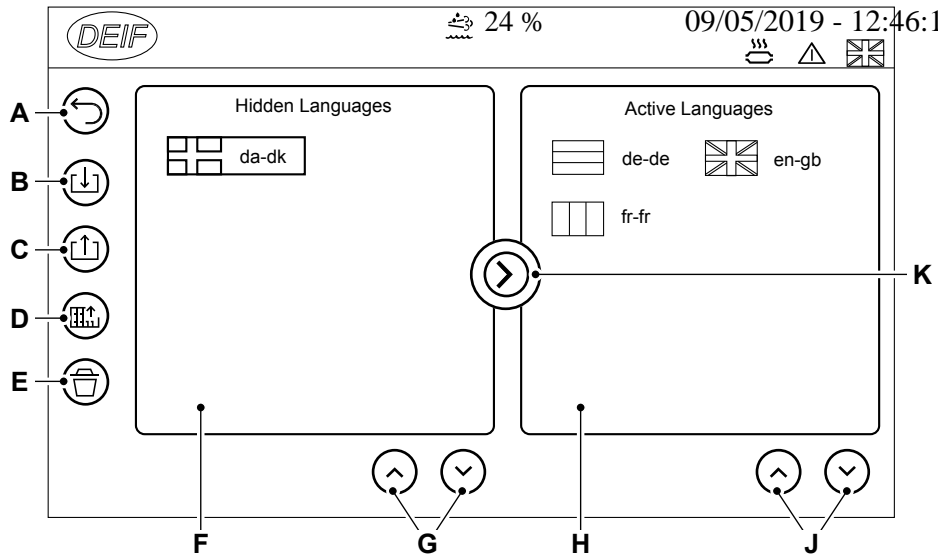

Table 26.

Sr. No.	Item	Description
A	Return	Returns to previous display.
B	Import	Imports all language files present on the USB (Universal Serial Bus) device.
C	Export	Exports the selected language to the USB device.
D	Create language	Create a new language file to the USB device.
E	Delete	Deletes the selected language file.
F	Hidden language list	Shows languages that are hidden from use.
G	Hidden language scroll page	Scrolls page up or down.
H	Active languages list	Shows languages that are active for use.
J	Active languages scroll page	Scrolls page up or down.
K	Move selected language	Move the selected language file.

(For: Control Panel 7310)

▲ WARNING Electric shock hazard. High voltage can cause serious injury or death. Make sure that all work is performed by qualified personnel. All cabling to the load must comply with the applicable laws and electrical standards.

Notice: Possibility of equipment damage. Proper sizing is critical to the operation and performance of the generator. Make sure that the load is sized correctly for the capacity of your generator and cables.

This is the stand alone generator controller. DSE 7310 can not synchronize.

The following description details the sequences followed by a module containing the standard 'factory configuration'. Always refer to your configuration source for the exact sequences and timers observed by any particular module in the field.

Control of the module is via push buttons mounted on the front of the module which need to be operated for the normal operation. Refer to Table 27.

The module may instruct an engine start event due to external influences. Therefore, it is possible for the engine to start at any time without warning when it is set to Automatic Mode. Prior to performing any maintenance on the system, it is recommended that steps are taken to remove the battery and isolate supplies.

Figure 51.

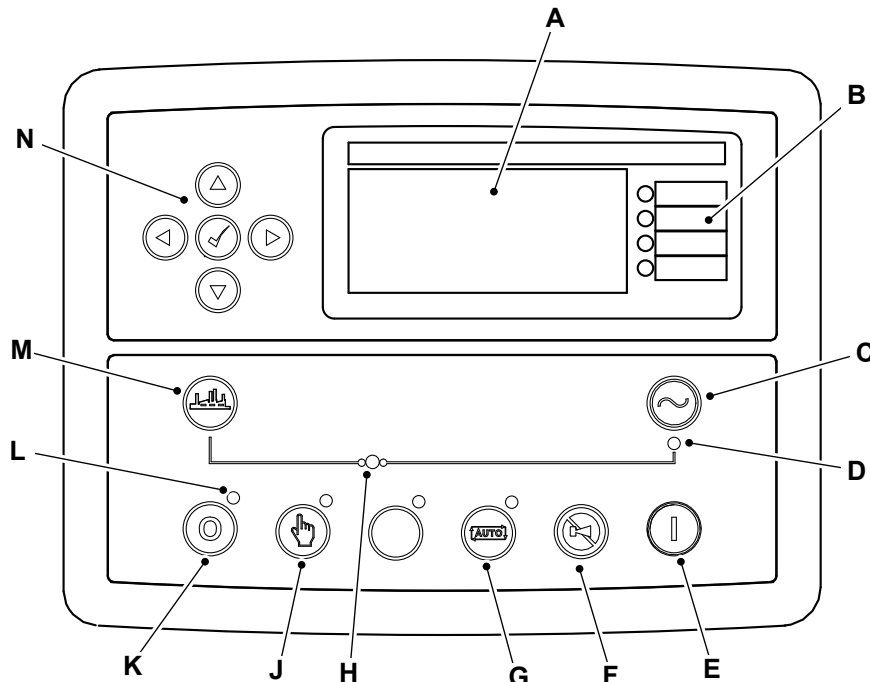

- A Module display
- B Four configurable status LED
- C Close generator
- D Generator available LED
- E Start button
- F Alarm mute and lamp test
- G Automatic mode
- H Generator breaker LED (not used)
- J Manual mode
- K Stop/reset button
- L Selected mode indication LED
- M Open generator (manual mode only)
- N Module display Menu navigation buttons

Control Push-Buttons

Table 27. Control panel 7310

	<p>This button places the module into its STOP/RESET mode. This will clear any alarm conditions for which the triggering criteria have been removed. If the engine is running and the module is put into STOP/RESET mode, the module will automatically instruct the generator to unload ('Close Generator output' becomes inactive). In STOP/RESET mode the generator remains at rest.</p>
	<p>This button places the module into its MANUAL mode. Once in MANUAL mode, the module responds to the start button to start the generator and run it off load. The MCCB (Molded Case Circuit Breaker) need to be closed manually.</p>
	<p>This button places the module into its AUTO MODE. This mode allows the module to control the function of the generator automatically. The module monitors numerous start requests via digital input, PLC and MSC link and when one has been made, the set is automatically started. Once the generator is available, the module automatically instructs the generator to synchronize and once in sync, to be place the generator on load ('Close Generator Output' becomes active). Upon removal of the starting signal, the module starts the Return Delay Timer and once expired, the load is automatically ramped off the generator and then it is taken off load ('Close Generator Output' becomes inactive). The generator then continues to run for the duration of the Cooling Timer until it stops. The module then waits for the next start event.</p>

	<p>This button is only active in the STOP/RESET mode, MANUAL mode. Pressing the Start button in Stop/Reset Mode powers up the engine's ECU (Electronic Control Unit) but does not start the engine. This can be used to check the status of the CAN (Controller Area Network) communication and to prime the fuel system.</p>
	<p>Used for navigating the instrumentation, event log and configuration screens.</p>
	<p>Used to silences the audible alarm in the controller, de-activates the audible alarm output (if configured) and illuminates all of the LED on the module's fascia as a lamp test function.</p>

(For: Control Panel 8610)

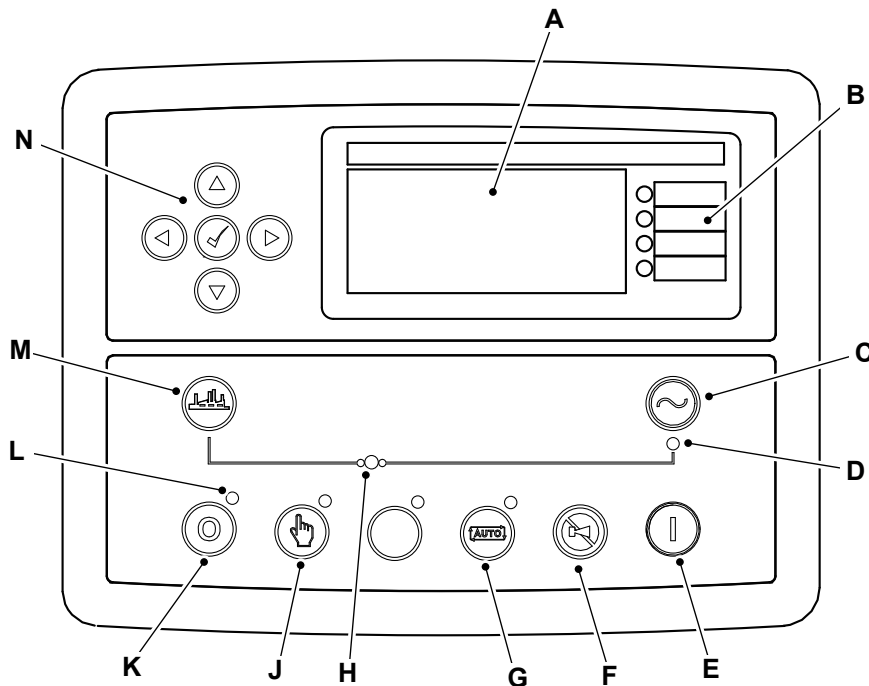

This is the stand alone generator controller. DSE 8610 can synchronize.

Figure 52.

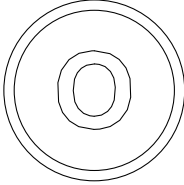

- | | |
|--|---|
| <p>A Module display
 C Close generator
 E Start button
 G Automatic mode
 J Manual mode
 L Selected mode indication LED
 N Module display Menu navigation buttons</p> | <p>B Four configurable status LED
 D Generator available LED
 F Alarm mute and lamp test
 H Generator breaker LED
 K Stop/reset button
 M Open generator (manual mode only)</p> |
|--|---|

Table 28. Control Panel 8610

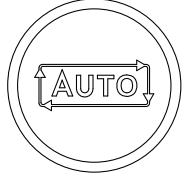
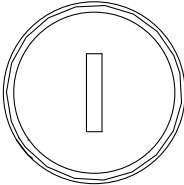
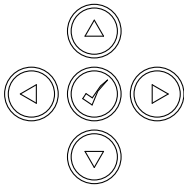
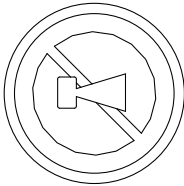
	<p>This button places the module into its STOP/RESET mode. This will clear any alarm conditions for which the triggering criteria have been removed. If the engine is running and the module is put into STOP/RESET mode, the module will automatically instruct the generator to unload ('Close Generator output' becomes inactive). In STOP/RESET mode the generator remains at rest.</p>
	<p>This button places the module into its MANUAL mode. Once in MANUAL mode, the module responds to the start button to start the generator and run it off load. To place the generator on load, use the 'Transfer to Generator' button. The module automatically instructs the generator to synchronize and once in sync, to be place the generator on load ('Close Generator Output' becomes active). To place the generator off load, use the 'Open Generator' button. The module automatically ramps the load off the generator and then takes it off load ('Close Generator Output' becomes inactive). Additional digital inputs are available to perform these functions. If the generator is running off-load in MANUAL mode and on load signal becomes active, the module automatically instructs the generator to synchronize and once in sync, to be place the generator on load ('Close Generator Output' becomes active). Upon removal of the on load signal, the generator remains on load until either selection of the 'STOP/RESET' mode or 'AUTO' mode.</p>
	<p>This button places the module into its AUTO MODE. This mode allows the module to control the function of the generator automatically. The module monitors numerous start requests via digital input, PLC and MSC link and when one has been made, the set is automatically started. Once the generator is available, the module automatically instructs the generator to synchronize and once in sync, to be place the generator on load ('Close Generator Output' becomes active). Upon removal of the starting signal, the module starts the Return Delay Timer and once expired, the load is automatically ramped off the generator and then it is taken off load ('Close Generator Output' becomes inactive). The generator then continues to run for the duration of the Cooling Timer until it stops. The module then waits for the next start event.</p>
	<p>This button is only active in the STOP/RESET mode, MANUAL mode. Pressing the Start button in Stop/Reset Mode powers up the engine's ECU but does not start the engine. This can be used to check the status of the CAN communication and to prime the fuel system.</p>
	<p>Used for navigating the instrumentation, event log and configuration screens.</p>
	<p>Used to silences the audible alarm in the controller, de-activates the audible alarm output (if configured) and illuminates all of the LED on the module's facia as a lamp test function.</p>

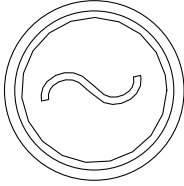
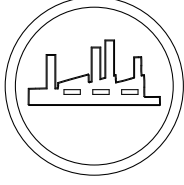
	<p>Close Generator- The Close Generator button controls the operation of the generator load switch and is only active in the Manual Mode once the generator is available. Pressing the Close Generator button when the generator is available and off load automatically instructs the generator to synchronize and once in sync, to be place the generator on load ('Close Generator Output' becomes active). If the generator bus is dead (has not supply on it) the generator is placed on load immediately. Further presses of the Close Generator button have no effect.</p>
	<p>Open Generator- The Open Generator button is only active in the Manual Mode and allows the operator to open the generator load switch. Pressing the Open Generator button when the Generator is on load, automatically ramps the load off the generator and then takes it off load ('Close Generator Output' becomes inactive). Further presses of the Open Generator button have no effect.</p>

Module Display

(For: Control Panel 7310, Control Panel 8610)

Protections (Alarms)

When an alarm is active, the internal audible alarm sounds and the common alarm output if configured, activates.

The audible alarm is silenced by pressing the alarm 'mute/ lamp' test button.

The LCD (Liquid Crystal Display) display jumps from the 'Information page' to display the alarm page.

Figure 53. Typical Alarm Message

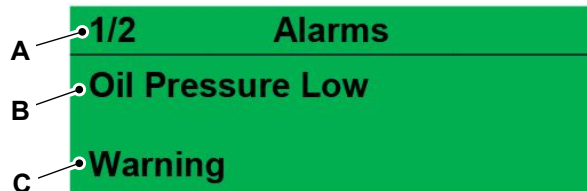

A Number of active alarm
C Type of alarm

B Cause of alarm

The LCD displays multiple alarms such as 'Coolant Temperature High', 'Emergency Stop' and 'Low Coolant Warning'. These automatically scroll in the order that they occurred or press the instrumentation navigation buttons to scroll through manually.

Protections Disabled

Configuration is possible to prevent shutdown and electrical trip alarms from stopping the generator. Under such conditions, protections disabled appears on the module display to inform the operator. Shutdown and electrical trip alarms still appear however, operator is informed the alarms are blocked.

Warning Alarms

Warnings are non-critical alarm conditions and do not affect the operation of the engine system, they serve to draw the operators attention to an undesirable condition.

In the event of an alarm the LCD jumps to the alarms page, and scroll through all active alarms.

By default, warning alarms are self-resetting when the fault condition is removed. However enabling all warnings are latched causes warning alarms to latch until reset manually. This is enabled using the controller configuration suite in conjunction with a compatible PC.

If the module is configured for CAN (Controller Area Network) and receives an “error” message from the ECU (Electronic Control Unit), ECU warning is shown on the module’s display as a warning alarm.

Table 29.

Fault	Description
Auxiliary Inputs	The module detects that an auxiliary input which has been user configured to create a fault condition has become active.
Analog Input Configured As Digital	The analog inputs can be configured to digital inputs. The module detects that an input configured to create a fault condition has become active.
Fail To Stop	The module has detected a condition that indicates that the engine is running when it has been instructed to stop. `Fail to Stop' could indicate a faulty oil pressure sensor. If engine is at rest check oil sensor wiring and configuration.
Charge Failure	The auxiliary charge alternator voltage is low as measured from the W/L terminal.
Low Fuel Level	The level detected by the fuel level sensor is below the low fuel level pre-set pre-alarm setting.
High Fuel Level	The level detected by the fuel level sensor is above the high fuel level pre-set pre-alarm setting.
Battery Under Voltage	The DC supply has fallen below or risen above the low volts preset pre-alarm setting.
Battery Over Voltage	The DC supply has risen above the high volts pre-set pre-alarm setting.
Generator Under Voltage	The generator output voltage has fallen below the pre-set prealarm setting after the Safety On timer has expired.
Generator Over Voltage	The generator output voltage has risen above the pre-set prealarm setting.
Generator Under Frequency	The generator output frequency has fallen below the pre-set prealarm setting after the Safety On timer has expired.
Generator Over Frequency	The generator output frequency has risen above the pre-set prealarm setting.
CAN ECU Fault	The engine ECU has detected an alarm.
CAN Data Fail	The module is configured for CAN operation and does not detect data on the engine CAN data link.
Immediate Over Current	The measured current has risen above the configured trip level.
Delayed Over Current	The measured current has risen above the configured trip level for a configured duration.
Oil Filter Maintenance Alarm	Maintenance due for oil filter.
Air Filter Maintenance Alarm	Maintenance due for air filter.
Fuel Filter Maintenance Alarm	Maintenance due for fuel filter.

Electrical Trip Alarms

Electrical trip alarms are latching and stop the generator but in a controlled manner. On initiation of the electrical trip condition the module de-activates the 'Close Gen Output' to remove the load from the generator. Once this has occurred the module starts the cooling timer and allows the engine to cool off-load before shutting down the engine. To restart the generator the fault must be cleared and the alarm reset.

In the event of an alarm the LCD jumps to the alarms page and scrolls through all active alarms.

Electrical trip alarms are latching alarms and to remove the fault, press the STOP/RESET mode button on the module.

Table 30.

Fault	Description
Auxiliary Inputs	The module detects that an auxiliary input which has been user configured to create a fault condition has become active.
Analog Input Configured As Digital	The analog inputs can be configured to digital inputs. The module detects that an input configured to create a fault condition has become active.
Low Fuel Level	The level detected by the fuel level sensor is below the low fuel level pre-set alarm setting.
High Fuel Level	The level detected by the fuel level sensor is above the high fuel level pre-set alarm setting.
Delayed Over Current	The measured current has risen above the configured trip level for a configured duration.
kW Overload	The measured kW has risen above the configured trip level for a configured duration.

Shutdown Alarms

Shutdown alarms are latching and immediately stop the Generator. On initiation of the shutdown condition the module de-activates the 'Close Gen Output' to remove the load from the generator. Once this has occurred, the module shuts the generator set down immediately to prevent further damage. To restart the generator the fault must be cleared and the alarm reset.

In the event of an alarm the LCD jumps to the alarms page and scrolls through all active alarms.

Shutdowns are latching alarms and to remove the fault, press the STOP/RESET Mode button on the module.

Table 31.

Fault	Description
Auxiliary Inputs	The module detects that an auxiliary input which has been user configured to create a fault condition has become active.
Analog Input Configured As Digital	The analog inputs can be configured to digital inputs. The module detects that an input configured to create a fault condition has become active.
Fail To Start	The engine has failed to start after the configured number of start attempts.
Low Oil Pressure	The module detects that the engine oil pressure has fallen below the low oil pressure pre-alarm setting level after the Safety On timer has expired.
Engine High Temperature	The module detects that the engine coolant temperature has exceeded the high engine temperature pre-alarm setting level after the 'Safety On' timer has expired.
Under Speed	The engine speed has fallen below the under speed pre alarm setting.
Over Speed	The engine speed has risen above the over speed pre alarm setting.
Charge Failure	The auxiliary charge alternator voltage is low as measured from the W/L terminal.
Low Fuel Level	The level detected by the fuel level sensor is below the low fuel level pre-set alarm setting.

Fault	Description
High Fuel Level	The level detected by the fuel level sensor is above the high fuel level pre-set alarm setting.
Generator Under Voltage	The generator output voltage has fallen below the pre-set alarm setting. after the Safety On timer has expired.
Generator Over Voltage	The generator output voltage has risen above the pre-set alarm setting.
Generator Under Frequency	The generator output frequency has fallen below the pre-set alarm setting after the 'Safety On' timer has expired.
Generator Over Frequency	The generator output frequency has risen above the pre-set alarm setting.
Delayed Over Current	The measured current has risen above the configured trip level for a configured duration.
kW Overload	The measured kW has risen above the configured trip level for a configured duration.
CAN ECU Fault	The engine ECU has detected an alarm - check engine light Contact Engine Manufacturer for support.
CAN Data Fail	The module is configured for CAN operation and does not detect data on the engine CAN data link.
Emergency Stop	The emergency stop button has been depressed. This failsafe (normally closed to emergency stop) input and immediately stops the set should the signal be removed.
Oil Sender Open Circuit	The oil pressure sensor has been detected as being open circuit.
Coolant Temperature Sender Open Circuit	The coolant temperature sensor has been detected as being open circuit.
Oil Filter Maintenance Alarm	Maintenance due for oil filter.
Air Filter Maintenance Alarm	Maintenance due for air filter.
Fuel Filter Maintenance Alarm	Maintenance due for fuel filter.

ECU Alarms (CAN Fault Codes /DTC)

When connected to a suitable CAN engine, the controller displays alarm status messages from the ECU in the alarms section of the display.

Figure 54.

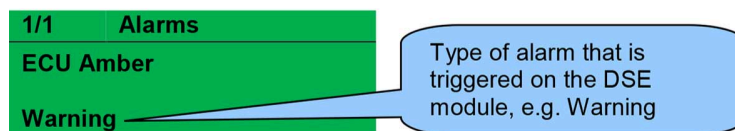

Press the next page button to access the list of current engine DTC (Diagnostic Trouble Code) from the ECU which are (Diagnostic Message 1) messages. Refer to Figure 55.

Figure 55.



Figure 56.

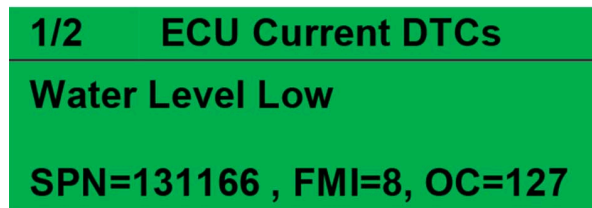

The (Diagnostic Message 1), DTC is interpreted by the module and is shown on the module's display as a text message. Refer to Figure 56.

Table 32.

Fault	DTC Description
Check Engine Fault	The engine ECU has detected a fault not recognized by the controller module, contact engine manufacturer for support.
Low Oil Pressure	The engine ECU has detected that the engine oil pressure has fallen below its configured low oil pressure alarm level.
Under Speed	The engine ECU has detected that the engine speed has fallen below its configured under speed alarm level.
Over Speed	The engine ECU has detected that the engine speed has risen above its configured over speed alarm level.
Charge Failure	The engine ECU has detected that the engine's charge alternator output has fallen below its configured alarm level.
Low Fuel Level	The engine ECU has detected that the engine's fuel level has fallen below its configured low fuel level alarm.
Battery Under/Over Voltage	The engine ECU has detected that the engine's DC supply has fallen below or risen above its configured alarm level.

Viewing The Instrument Pages

Navigation Menu

Use up and down navigation button for different options. Refer to Table 33.

Table 33.

Status >	< Engine >	< Genera- tor >	< Alarm >	< ECU DTC >	< Event Log >	< Serial Port >	< About	
Summery screen	Engine speed	Gen- volt- age (L-N)	Use up and down navi- gation but- ton for dif- ferent op- tions.	Use up and down navi- gation but- ton for dif- ferent op- tions.	Use up and down navi- gation but- ton for dif- ferent op- tions.	Use up and down navi- gation but- ton for dif- ferent op- tions.	Use up and down navi- gation but- ton for dif- ferent op- tions.	
Engine oil pressure	Engine oil pressure	Gen- volt- age (L-L)						
Engine coolant tem- perature	Engine coolant tem- perature	Gen- fre- quency						
Summery screen	Engine bat- tery voltage	Gen- cur- rent						
Engine bat- tery voltage	Engine run time	Gen- earth current						
	Fuel level	Gen- load (kW)						
	Mainte- nance alarm (hold 'O' to reset)	Gen- load (total kW)						
	Engine link	Gen- load (%)						
								Gen- load (total %)
								Gen- load (kVA)
								Gen- load (total kVA)
								Gen power factor
								Gen power factor (Avg)
								Gen- load (kVAr)
								Gen- load (total kVAr)
								Gen- load (h)
			Gen phase sequence					
			Active Con- figuration					
Active Con- figuration								

Event Log

The module maintains a log of past alarms and/or selected status changes. The log size has been increased in the module over past module updates and is always subject to change. As of now, the modules log is capable of storing the last 250 log entries.

Under default factory settings, the event log is configured to include all possible options; however, this is configurable by the system designer using the controller Configuration suite software.

Viewing The Event Log

To view the event log, repeatedly press the next or previous page buttons until the LCD screen displays the event Log page.

Figure 57.



A Number of events

Lifting the Machine

General

Use the central lifting eye or four lift eyes to lift (with spreaders) the generator set. For more information contact JCB dealer. Refer to Figure 58.

Figure 58.

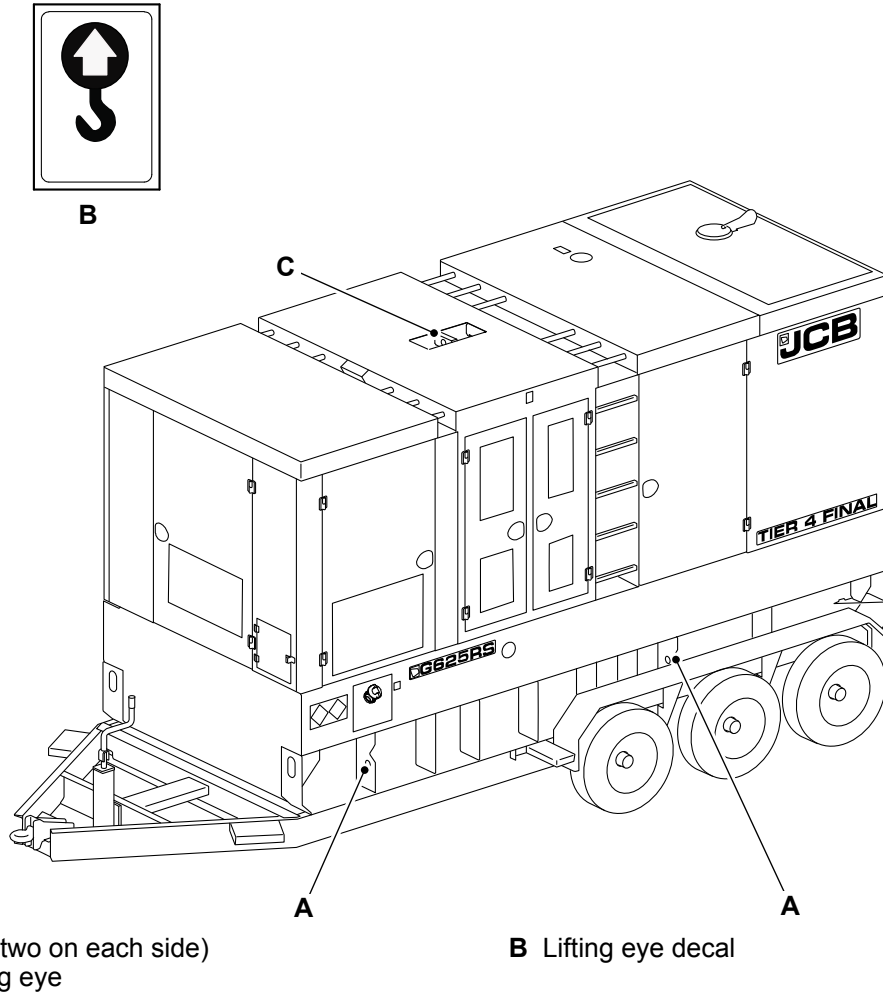

Refueling

Filling the Tank

▲ **WARNING** Fuel is flammable, keep naked flames away from the fuel system. Stop the engine immediately if a fuel leak is suspected. Do not smoke while refueling or working on the fuel system. Do not refuel with the engine running. Completely wipe off any spilt fuel which could cause a fire. There could be a fire and injury if you do not follow these precautions.

WARNING Switch off your cell phone before entering an area with a potentially explosive atmosphere. Sparks in such an area could cause an explosion or fire resulting in death or serious injury.

Switch off and do not use your cell phone when refueling the machine.

CAUTION Spilt fuel may cause skidding and therefore accidents. Clean any spilt fuel immediately.

Do not use fuel to clean the machine.

When filling with fuel, choose a well aired and ventilated area.

Notice: Consult your fuel supplier or JCB dealer about the suitability of any fuel you are unsure of.

1. Stop the machine and make it safe.
2. Get access to the fuel tank filler cap. Refer to Figure 59.
3. Remove all unwanted material around the fuel cap.
4. Remove the fuel cap.
5. Add the fuel through the filler neck as necessary.
6. Fuel level can be seen on the gage fitted on the top of the fuel tank.
7. Install the fuel cap.

Filling the Diesel Exhaust Fluid Tank

▲ **Notice:** Make sure that you use the DEF filler and not the fuel filler. Even small amounts of DEF in the fuel tank may damage the system. If there is any possibility that the fuel system has been contaminated with DEF, the engine must not be started before cleaning the system. Contact your JCB dealer.

1. Stop the machine and make it safe.
2. Get access to the fuel tank filler cap. Refer to Figure 59.
3. Remove all unwanted material around the DEF (Diesel Exhaust Fluid) cap.
4. Remove the DEF cap.
5. Add the DEF through the filler neck as necessary.
6. Install the DEF cap.
7. Lock the DEF cap to prevent theft and tampering.

The DEF level is shown on the instrument panel. You must fill the tank at the earliest opportunity when the warning indicator comes on.

Figure 59.

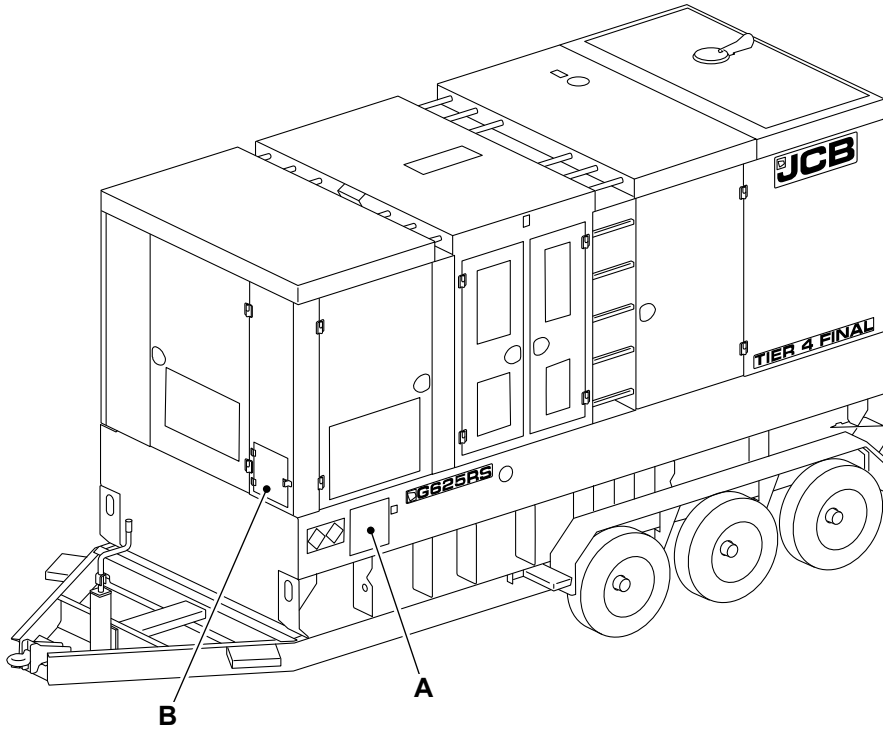

A Fuel filler cap

B DEF filler cap

Trailers

General

Towing a trailer requires care. Both the trailer and vehicle must be in good condition and securely fastened to each other to reduce the possibility of an accident.

- Verify the hitch and coupling on the towing vehicle are related equal to, or greater than, the trailer's gross vehicle weight rating.
- Check trailer tires for wear and proper inflation.
- Check the condition/operation of the lights.
- Do not tow trailer using defective parts. Inspect the hitch and coupling for wear or damage.
- Verify the trailer hitch and the coupling are compatible. Make sure the coupling is securely fastened to the vehicle.
- Verify wheel lug nuts are present and tightened to the specified torque.
- When towing, maintain extra space between vehicles and avoid soft shoulders, curbs and sudden lane changes. Practice turning, stopping and backing up in an area away from heavy traffic prior to transporting the unit.
- Connect safety chains in a crossing pattern under the tongue and attach the breakaway cable to a suitable rear part of the towing vehicle. Do not attach the cable to the trailer hitch.
- The trailer is equipped with electric surge brakes. Verify proper operation of the brakes by braking the vehicle at a slow speed before entering traffic. Both the trailer and the vehicle should brake smoothly. If the trailer seems to be pushing, verify the level in the brake fluid reservoir, if equipped.



Notes:

Preservation and Storage Cleaning

General

1. Stop the machine and allow it to cool for at least one hour. Do not attempt to clean any part of the machine while it is running.
2. Ensure all electrical loads are disconnected and the generator is made safe by disconnecting at the breaker, turning off the machine and activating the emergency stop switch.
3. Make sure that all electrical connectors are correctly coupled. If connectors are open, install the correct caps or seal with waterproof tape.
4. Make sure that the oil filler caps and dipstick are correctly installed.
5. Apply an approved cleaning and degreasing agent with a brush. Obey the manufacturers instructions.
6. Wipe the outer body with a clean cloth.
7. Make sure that the machine is fully dry before operating. If necessary, use an external blower or heater.



Security

LiveLink

Your JCB machine may be installed with LiveLink, JCB's advanced machine monitoring system. LiveLink monitors a range of information about your machine and sends it through cellular and satellite communication back to JCB's secure monitoring center.

The machine owners and JCB dealers can then view that information through the LiveLink website, by email and even through text message. If you want to know how LiveLink can help manage your JCB machines, contact your local dealer for more information.

Maintenance

Introduction

General

▲ WARNING The engine has exposed rotating parts. Switch off the engine before working in the engine compartment. Do not use the machine with the engine cover open.

WARNING The machine can start automatically. You must isolate the engine start circuit before you start service or maintenance procedures.

CAUTION Understand the electrical circuit before connecting or disconnecting an electrical component. A wrong connection can cause injury and/or damage.

CAUTION To avoid burning, wear personal protective equipment when handling hot components. To protect your eyes, wear goggles when using a brush to clean components.

It is recommended that set maintenance is carried out on a regular basis. Machine maintenance requirements should be followed to maintain warranty validity. [Refer to: Maintenance Schedules \(Page 75\)](#). A regular preventative maintenance schedule is highly recommended in order to preserve the life of the generating set. A generating set in stand-by application and in a healthy environment will require visual inspection approximately once a month, while the same generating set in dusty, damp or humid climates will require inspection and maintenance more often than this. Generating set preventative maintenance depends on generating set environment, application and workload all these factors should be taken into consideration when planning a maintenance schedule for the machine.

Daily checks should include a minimum of visual inspections for fluid leaks, loose connections, contamination, debris etc. in addition to the recommended maintenance tasks.

If the generator is not being sufficiently loaded on a regular basis it may cause coking of the engine and exhaust system which may cause excessive smoke and contamination of the lubrication oil. To avoid this problem ensure the load on the generator is suitable (typically 60% or more of the generator maximum load). If this problem does occur, then additional load will need to be applied to rectify the problem.

Connecting a load bank (additional electrical load) should be a routine action at normal service intervals if the machine regularly operates at part load (less than 60%). In addition the lubrication oil should also be assessed and a reduced service interval (possibly 50% of the recommended interval) should be adopted.

Equipment utilizing the engine must be correctly switched off and prepared, for example safety circuit breakers tripped, prior to completing maintenance tasks on the engine. Maintenance must be completed by suitably qualified personnel. You or others could be killed or seriously injured if the machine is not correctly prepared and maintained. To obtain the best performance from your engine, make sure that the service tasks are completed at the recommended period. If the machine/engine is working in adverse conditions, then the service intervals should be reduced, examples of adverse conditions are:

- operating in a very dusty environment
- operating at light load for long periods
- operating in an environment with lots of chaff
- operating in an extremely hot or cold environment
- operating continuously at high altitude
- operating in an environment with high humidity
- operating with a low quality fuel.

Maintenance Safety

General

Exhaust Gases

Machine exhaust gases can harm and possibly kill you or bystanders if they are inhaled. Do not operate the machine in closed spaces without making sure there is good ventilation. If possible, install an exhaust extractor. If you begin to feel drowsy, stop the machine at once and get into fresh air.

Communications

Bad communications can cause accidents. If two or more people are working on the machine, make sure each is aware of what the others are doing. Before starting the engine make sure the others are clear of the danger areas. Examples of danger areas are: the rotating blades and belt on the engine, the attachments and linkages, and anywhere beneath or behind the machine. People can be killed or injured if these precautions are not taken.

Machine Modifications

This machine is manufactured in compliance with prevailing legislative requirements. It must not be altered in any way which could affect or invalidate its compliance. For advice consult your JCB dealer.

Repairs

If your machine does not function correctly in any way, get it repaired straight away. Neglect of necessary repairs could result in an accident or affect your health. Do not try to do repairs or any other type of maintenance work you do not understand. To avoid injury and/or damage get the work done by a specialist engineer.

'O' rings, Seals and Gaskets

Badly installed, damaged or rotted 'O' rings, seals and gaskets can cause leakages and possible accidents. Renew whenever disturbed unless otherwise instructed. Do not use Trichloroethane or paint thinners near 'O' rings and seals.

Hot Components

Touching hot surfaces can burn skin. The engine and machine components will be hot after the unit has been running. Allow the engine and components to cool before servicing the unit.

Chemicals

Certain seals and gaskets (e.g. crankshaft oil seal) on JCB machines contain fluoroelastomeric materials such as Viton®, Fluorel™ and Technoflon®. Fluoroelastomeric materials subjected to high temperatures can produce highly corrosive hydrofluoric acid. This acid can severely burn. New fluoroelastomeric components at ambient temperature require no special safety precautions. Used fluoroelastomeric components whose temperatures have not exceeded 300 °C (571.6 °F) require no special safety precautions. If evidence of decomposition (e.g. charring) is found, refer to the next paragraph for safety instructions. Do not touch component or surrounding area. Used fluoroelastomeric components subjected to temperatures greater than 300 °C (571.6 °F) (e.g. engine fire) must be treated using the following safety procedure. Make sure that heavy duty gloves and special safety glasses are worn: Thoroughly wash contaminated area with 10% calcium hydroxide or other suitable alkali solution, if necessary use wire wool to remove burnt remains. Thoroughly wash contaminated area with detergent and water. Contain all removed material, gloves etc. used in this operation in sealed plastic bags and dispose of in accordance with Local Authority Regulations. Do not burn fluoroelastomeric materials.

Oil

Oil is toxic. If you swallow any oil, do not induce vomiting, seek medical advice. Used engine oil contains harmful contaminants which can cause skin cancer. Do not handle used engine oil more than necessary. Always use barrier cream or wear gloves to prevent skin contact. Wash skin contaminated with oil thoroughly in warm soapy water. Do not use gas, diesel fuel or paraffin to clean your skin.

Fuel

Fuel is flammable, keep naked flames away from the fuel system. Stop the engine immediately if a fuel leak is suspected. Do not smoke while refueling or working on the fuel system. Do not refuel with the engine running. Completely wipe off any spilt fuel which could cause a fire. There could be a fire and injury if you do not follow these precautions.

Fires

If your machine is equipped with a fire extinguisher, make sure it is checked regularly. Keep it in the correct machine location until you need to use it.

Do not use water to put out a machine fire, you could spread an oil fire or get a shock from an electrical fire. Use carbon dioxide, dry chemical or foam extinguishers. Contact your nearest fire department as quickly as possible.

Fluids and Lubricants

Oil

Oil is toxic. If you swallow any oil, do not induce vomiting, seek medical advice. Used engine oil contains harmful contaminants which can cause skin cancer. Do not handle used engine oil more than necessary. Always use barrier cream or wear gloves to prevent skin contact. Wash skin contaminated with oil thoroughly in warm soapy water. Do not use gas, diesel fuel or paraffin to clean your skin.

Fuel

Fuel is flammable, keep naked flames away from the fuel system. Stop the engine immediately if a fuel leak is suspected. Do not smoke while refueling or working on the fuel system. Do not refuel with the engine running. Completely wipe off any spilt fuel which could cause a fire. There could be a fire and injury if you do not follow these precautions.

Antifreeze

Never perform checks or maintenance on the cooling system when it is hot. Never remove radiator cap when engine is hot - severe risk of scalding. Never remove radiator cap when the engine is running. Antifreeze is toxic. If accidentally swallowed, medical advice must be sought immediately. Antifreeze is corrosive to the skin. If accidentally spilled on to skin, it must be washed off immediately. Protective clothing and eye protection must be worn when handling antifreeze.

Hygiene

JCB lubricants are not a health risk when used correctly for their intended purposes.

However, excessive or prolonged skin contact can remove the natural fats from your skin, causing dryness and irritation.

Low viscosity oils are more likely to do this, so take special care when handling used oils, which might be diluted with fuel contamination.

Whenever you are handling oil products you must maintain good standards of care and personal and plant hygiene. For details of these precautions we advise you to read the relevant publications issued by your local health authority, plus the following.

Storage

Always keep lubricants out of the reach of children.

Never store lubricants in open or unlabeled containers.

Waste Disposal

▲ CAUTION It is illegal to pollute drains, sewers or the ground. Clean up all spilt fluids and/or lubricants.

Used fluids and/or lubricants, filters and contaminated materials must be disposed of in accordance with local regulations. Use authorized waste disposal sites.

CAUTION Damaged or spent batteries and any residue from fires or spillage must be put in a suitable closed receptacle and must be disposed of in accordance with local environmental waste regulations.

All waste products must be disposed of in accordance with all the relevant regulations.

The collection and disposal of used oil must be in accordance with any local regulations. Never pour used engine oil into sewers, drains or on the ground.

Handling

▲ **CAUTION** The temperature of the hydraulic oil will be high soon after stopping the machine. Wait until it cools before beginning maintenance.

New Oil

There are no special precautions needed for the handling or use of new oil, beside the normal care and hygiene practices.

Used Oil

Used engine crankcase lubricants contain harmful contaminants.

Here are precautions to protect your health when handling used engine oil:

- Avoid prolonged, excessive or repeated skin contact with used oil
- Apply a barrier cream to the skin before handling used oil. Note the following when removing engine oil from skin:
 - Wash your skin thoroughly with soap and water
 - Using a nail brush will help
 - Use special hand cleansers to help clean dirty hands
 - Never use gas, diesel fuel, or paraffin for washing
- Avoid skin contact with oil soaked clothing
- Don't keep oily rags in pockets
- Wash dirty clothing before re-use
- Throw away oil-soaked shoes

First Aid - Oil

Eyes

In the case of eye contact, flush with water for 15min. If irritation persists, get medical attention.

Swallowing

If oil is swallowed do not induce vomiting. Get medical advice.

Skin

In the case of excessive skin contact, wash with soap and water.

Spillage

Absorb with sand or a locally approved brand of absorbent granules. Scrape up and remove to a chemical disposal area.

Fires

▲ **WARNING** Do not use water to put out an oil fire. This will only spread it because oil floats on water.
Extinguish oil and lubricant fires with carbon dioxide, dry chemical or foam.

Battery

▲ **DANGER** Batteries give off an explosive gas. Do not smoke when handling or working on the battery. Keep the battery away from sparks and flames.

Battery electrolyte contains sulfuric acid. It can burn you if it touches your skin or eyes. Wear goggles. Handle the battery carefully to prevent spillage. Keep metallic items (watches, rings, zippers etc) away from the battery terminals. Such items could short the terminals and burn you.

Set all switches to off before disconnecting and connecting the battery. When disconnecting the battery, take off the earth (-) lead first.

Re-charge the battery away from the machine, in a well ventilated area. Switch the charging circuit off before connecting or disconnecting the battery. When you have installed the battery in the machine, wait 5 min before connecting it up.

When reconnecting, attach the positive (+) lead first.

WARNING Battery electrolyte is toxic and corrosive. Do not breathe the gases given off by the battery. Keep the electrolyte away from your clothes, skin, mouth and eyes. Wear safety glasses.

CAUTION Understand the electrical circuit before connecting or disconnecting an electrical component. A wrong connection can cause injury and/or damage.

Notice: Do not disconnect the battery while the engine is running, otherwise the electrical circuits may be damaged.

CAUTION The machine is negatively earthed. Always connect the negative pole of the battery to earth.

When connecting the battery, connect the earth (-) lead last.

When disconnecting the battery, disconnect the earth (-) lead first.

DANGER If you try to charge a frozen battery, or jump start and run the engine, the battery could explode. Do not use a battery if its electrolyte is frozen. To prevent the battery electrolyte from freezing, keep the battery at full charge.

Notice: Before carrying out arc welding on the machine, disconnect the battery and alternator to protect the circuits and components. The battery must still be disconnected even if a battery isolator is installed.

Warning Symbols

The following warning symbols may be found on the battery.

Figure 60.

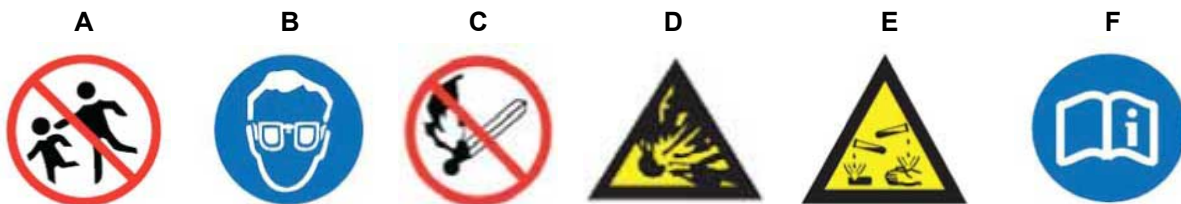

- A Keep away from children
- C No smoking, no naked flames, no sparks
- E Battery acid

- B Shield eyes
- D Explosive gas
- F Note operating instructions

Disposal

When the battery reaches the end of its usual life it must be removed from the machine and recycled in an approved way in accordance with local environmental regulations. This service is usually operated by battery vendors. Machine users that cannot find a suitable battery recycling facility should contact their JCB dealer for assistance.

First Aid - Electrolyte

Eyes

In the case of eye contact, flush with water for 15min. always get medical attention.

Swallowing

Do not induce vomiting. Drink large quantities of water or milk. Then drink milk of magnesia, beaten egg or vegetable oil. Get medical help.

Skin

Flush with water, remove affected clothing. Cover burns with a sterile dressing then get medical help.

Maintenance Schedules

General

A poorly maintained machine is a hazard. Doing the regular maintenance and lubrication jobs listed in these schedules will help keep the machine in safe running order.

Generators may be used in either 'Prime' or 'Stand-by' applications. Minimum annual servicing is included to cover 'Stand-by' units where minimal hours will be accumulated.

Apart from the daily jobs, the schedules are based on machine running hours. Keep a regular check on the hourmeter readings to correctly gage service intervals. Do not use a machine which is due for a service. Make sure any defects found during the regular maintenance checks are rectified immediately.

How to Use the Maintenance Schedules

The schedules show the service tasks which must be done and their intervals.

The services must be done at either the hourly interval or the calendar equivalent, whichever occurs first.

The intervals given in the schedules must not be exceeded. If the machine is operated under severe conditions (high temperature, dust, water, etc.) shorten the intervals.

Table 34.

○	Service task can be completed by a competent operator. Details of how to complete the service task are given in the Operator's Manual.
□	We recommend that a Service Engineer completes the service task. Details of how to complete the service task are given in the Service Manual.

Maintenance Intervals

Table 35.

Interval (h)	Calendar Equivalent
10	Daily
50	Weekly
500	Six months
1000	Yearly
2000	Two years
6000	Six years
8000	Eight years

Pre-start Cold Checks, Service Points and Fluid Levels

Table 36.

	Operation	Interval (h)							Annually	
		10	50	500	1000	2000	6000	8000		
Overall Machine										
Visual inspection	Overall visual check	○	○	□	□	□	□	□	□	
Control Panel	Check operation	○	○	□	□	□	□	□	□	
Safety decals	Check condition		○	□	□	□	□	□	□	
Emergency stop switches	Check operation		○	□	□	□	□	□	□	
Earth Leakage RCD and MCB ⁽¹⁾	Check operation		○	□	□	□	□	□	□	
External Power Socket Box ⁽²⁾	Check condition		○	□	□	□	□	□	□	



	Operation	Interval (h)							Annually
		10	50	500	1000	2000	6000	8000	
Battery Terminals and voltage	Check			<input type="checkbox"/>	<input type="checkbox"/>	<input type="checkbox"/>	<input type="checkbox"/>	<input type="checkbox"/>	
Control panel events history	Check			<input type="checkbox"/>	<input type="checkbox"/>	<input type="checkbox"/>	<input type="checkbox"/>	<input type="checkbox"/>	
Bus bar cover safety switch	Check operation			<input type="checkbox"/>	<input type="checkbox"/>	<input type="checkbox"/>	<input type="checkbox"/>	<input type="checkbox"/>	
Alternator and engine mounting bolts	Check tightness			<input type="checkbox"/>	<input type="checkbox"/>	<input type="checkbox"/>	<input type="checkbox"/>	<input type="checkbox"/>	
Bus bar terminals	Check tightness			<input type="checkbox"/>	<input type="checkbox"/>	<input type="checkbox"/>	<input type="checkbox"/>	<input type="checkbox"/>	
Machine earth connections	Check condition			<input type="checkbox"/>	<input type="checkbox"/>	<input type="checkbox"/>	<input type="checkbox"/>	<input type="checkbox"/>	
Engine and controller harness	Check condition and connections			<input type="checkbox"/>	<input type="checkbox"/>	<input type="checkbox"/>	<input type="checkbox"/>	<input type="checkbox"/>	
Load Test (as per usage and applications)	Load Test @ 100% of maximum load								<input type="checkbox"/>
Engine									
Coolant Quality and Level	Check	<input type="radio"/>	<input type="radio"/>	<input type="checkbox"/>	<input type="checkbox"/>	<input type="checkbox"/>	<input type="checkbox"/>	<input type="checkbox"/>	
Oil Level	Check	<input type="radio"/>	<input type="radio"/>	<input type="checkbox"/>	<input type="checkbox"/>	<input type="checkbox"/>	<input type="checkbox"/>	<input type="checkbox"/>	
Water Separator and Engine Fuel Filter	Drain/Clean		<input type="radio"/>	<input type="checkbox"/>	<input type="checkbox"/>	<input type="checkbox"/>	<input type="checkbox"/>	<input type="checkbox"/>	
Oil and Filter	Change			<input type="checkbox"/>	<input type="checkbox"/>	<input type="checkbox"/>	<input type="checkbox"/>	<input type="checkbox"/>	
Water Separator Fuel Filter	Change				<input type="checkbox"/>	<input type="checkbox"/>	<input type="checkbox"/>	<input type="checkbox"/>	
Engine Fuel Filter	Change			<input type="checkbox"/>	<input type="checkbox"/>	<input type="checkbox"/>	<input type="checkbox"/>	<input type="checkbox"/>	
Front End Accessory Drive (FEAD) Belt, Belt Tensioner and Idler Wheels Condition	Check			<input type="checkbox"/>	<input type="checkbox"/>	<input type="checkbox"/>	<input type="checkbox"/>	<input type="checkbox"/>	
Engine Mounting Bolts for Tightness	Check			<input type="checkbox"/>	<input type="checkbox"/>	<input type="checkbox"/>	<input type="checkbox"/>	<input type="checkbox"/>	
All Hoses - Condition	Check			<input type="checkbox"/>	<input type="checkbox"/>	<input type="checkbox"/>	<input type="checkbox"/>	<input type="checkbox"/>	
Radiator	Check			<input type="checkbox"/>	<input type="checkbox"/>	<input type="checkbox"/>	<input type="checkbox"/>	<input type="checkbox"/>	
Breather Gauze	Clean					<input type="checkbox"/>	<input type="checkbox"/>	<input type="checkbox"/>	
Valve Clearances	Check and Adjust				<input type="checkbox"/>	<input type="checkbox"/>	<input type="checkbox"/>	<input type="checkbox"/>	
Oil Filler and Dipstick Seals	Check and Adjust					<input type="checkbox"/>	<input type="checkbox"/>	<input type="checkbox"/>	
Rocker Cover and Injector Seals	Change					<input type="checkbox"/>	<input type="checkbox"/>	<input type="checkbox"/>	
Injectors	Change						<input type="checkbox"/>		
Injector(s) Leak Off Rail	Change						<input type="checkbox"/>		
High Pressure Fuel Lines	Inspect						<input type="checkbox"/>		
Front End Accessory Drive (FEAD) Belt	Change					<input type="checkbox"/>	<input type="checkbox"/>	<input type="checkbox"/>	<input type="checkbox"/>
Battery Terminals and voltage	Check			<input type="checkbox"/>	<input type="checkbox"/>	<input type="checkbox"/>	<input type="checkbox"/>	<input type="checkbox"/>	
Software status	Check			<input type="checkbox"/>	<input type="checkbox"/>	<input type="checkbox"/>	<input type="checkbox"/>	<input type="checkbox"/>	



	Operation	Interval (h)							Annually
		10	50	500	1000	2000	6000	8000	
Air Cleaner	Check			<input type="checkbox"/>	<input type="checkbox"/>	<input type="checkbox"/>	<input type="checkbox"/>	<input type="checkbox"/>	
Air Cleaner	Change				<input type="checkbox"/>	<input type="checkbox"/>	<input type="checkbox"/>	<input type="checkbox"/>	
Coolant	Replace							<input type="checkbox"/>	
Main Alternator									
Generator Alternator ca- bles ⁽³⁾	Check condition			<input type="checkbox"/>	<input type="checkbox"/>	<input type="checkbox"/>	<input type="checkbox"/>	<input type="checkbox"/>	
Generator Alternator Terminals	Check tightness			<input type="checkbox"/>	<input type="checkbox"/>	<input type="checkbox"/>	<input type="checkbox"/>	<input type="checkbox"/>	

(1) If installed.

(2) Check seals and O-rings are in place, check covers close securely. Replace if there is any sign of wear.

(3) Replace if there is any sign of wear.

Maintenance Positions

Maintenance Position

1. Turn off all loads to the generator.
2. Set the MCB (Miniature Circuit Breaker) to 'off' position.
3. Open the main circuit breaker. The power available lamp will go off.
4. Press the 'stop/reset' button once. The generator will stop after the specified cooling time.
Duration: 5min
 - 4.1. If 'stop/reset' button is pressed again then generator will stop immediately.
5. Ready to load and generator available LED (Light Emitting Diode) indicators will go off.
6. Turn the battery isolator to 'off' position after the engine has stopped.

Access Apertures

General

Figure 61.

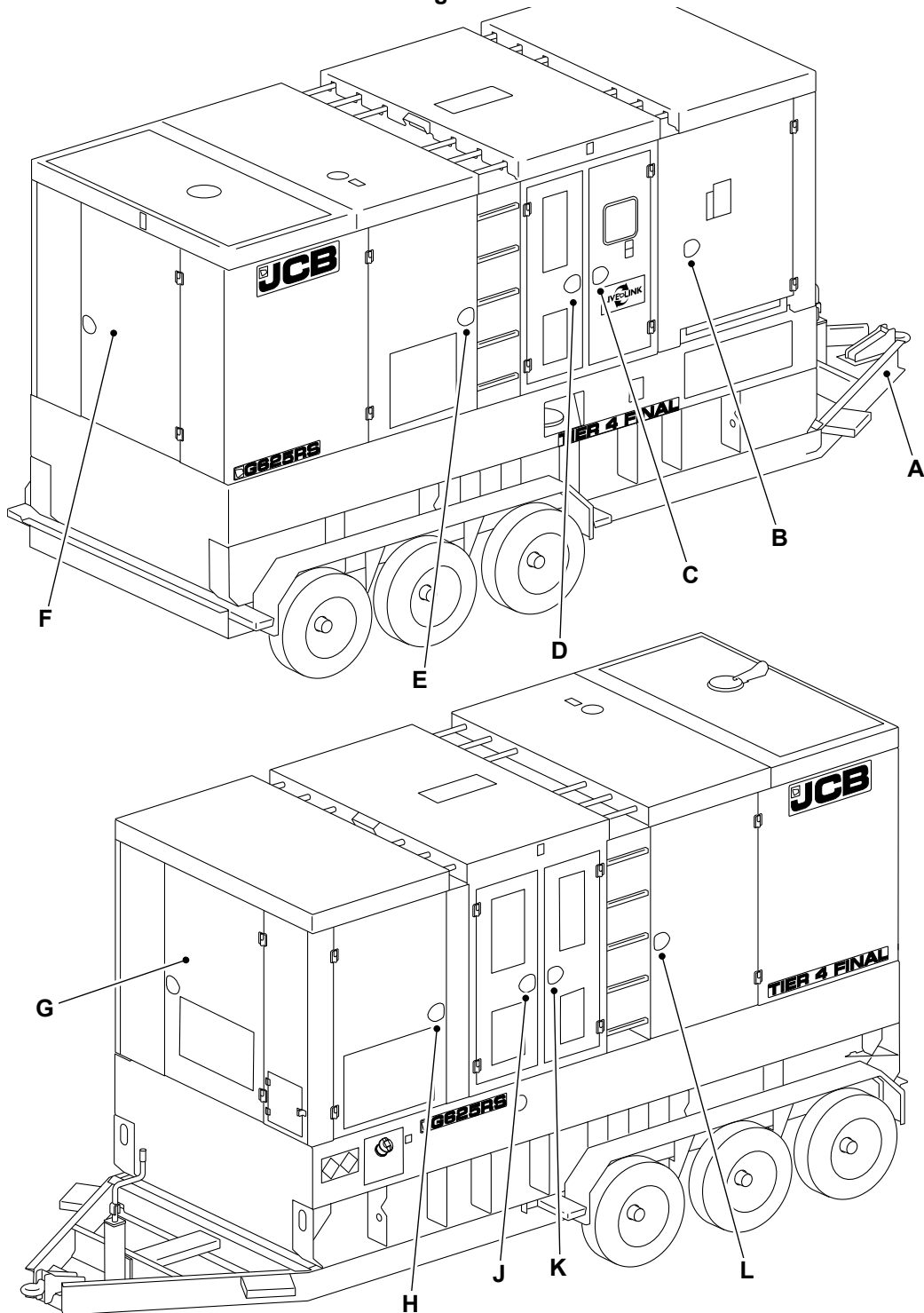

- A Trailer
- C Right center front door
- E Rear right door
- G Front door
- J Left center front door
- L Left rear door

- B Right front door
- D Right center rear door
- F Rear door
- H Left front door
- K Left center rear door

Engine

General

Clean

▲ Notice: Clean the engine before you start engine maintenance. Obey the correct procedures. Contamination of the fuel system will cause damage and possible failure of the engine.

Notice: The engine or certain components could be damaged by high pressure washing systems; special precautions must be taken if the engine is to be washed using a high pressure system. Ensure that the engine air intake, alternator, starter motor and any other electrical components are shielded and not directly cleaned by the high pressure cleaning system.

Before carrying out any service procedures that require components to be removed, the engine must be properly cleaned.

Cleaning must be carried out either in the area of components to be removed or, in the case of major work, or work on the fuel system, the whole engine and surrounding engine must be cleaned.

Stop the engine and allow it to cool for at least one hour. Do not attempt to clean any part of the engine while it is running.

1. Make sure that the electrical system is isolated.
2. Make sure that all electrical connectors are correctly coupled. If connectors are open fit the correct caps or seal with water proof tape.
3. Cover the alternator with a plastic bag to prevent water ingress.
4. Seal the engine air intake, exhaust and breather system.
5. Make sure that the oil filler caps and dipstick are correctly installed.
6. Use a low pressure water jet and soft bristle brush to soak off caked mud or dirt.
7. Apply an approved cleaning and degreasing agent with a brush. Obey the manufacturers instructions.
8. Use a pressure washer to remove the soft dirt and oil. Important: DO NOT aim the water jet directly at oil seals or electrical and electronic components such as the engine ECU (Electronic Control Unit), alternator or fuel injectors. Do not place the jet nozzle closer than the distance specified to any part of the engine or aftertreatment system.
Length/Dimension/Distance: 600mm (23 $\frac{1}{2}$ in)
9. When the pressure washing is complete move the engine away from the wash area, or alternatively, clean away the material washed from the engine.
10. Before working on specific areas of the engine use a compressed air jet to dry off any moisture. When the area is dry use a soft clean brush to remove any sand or grit particles that remain.
11. When removing components be aware of any dirt or debris that may be exposed. Cover any open ports and clean away the deposits before proceeding

Additional cleaning must be carried out prior to working on the high pressure fuel system.

Check (Condition)

Start the engine and check for:

- Excessive smoke
- Excessive vibration
- Excessive noise
- Overheating
- Performance
- Unusual smells.

Oil

Check (Leaks)

Before you start the machine, do a check for oil leaks:

1. Make the machine safe.
2. Get access to the engine compartment (if applicable)
3. Check the engine and the area below for oil leaks.
4. Close the engine cover (if applicable).
5. If necessary, contact your JCB dealer.

Check (Level)

▲ WARNING Never check the oil level or add oil with the engine running. Be careful of hot lubricating oil. Danger of scalding.

Notice: Do not exceed the maximum level of engine oil in the sump. If the maximum is exceeded, the excess must be drained to the correct level. An excess of engine oil could cause the engine speed to increase rapidly without control.

1. Make the machine safe.
2. Wait for the oil to drain back into the engine sump before you take a reading. If not, a false low reading may be recorded which can cause the engine to be overfilled.
3. Get access to the engine.
4. Remove and clean the dipstick.
5. Replace the dipstick.
6. Remove the dipstick.
7. Check the oil level. The oil should be between the two marks on the dipstick.
8. If necessary, add more oil:
 - 8.1. Remove the filler cap.
 - 8.2. Add the recommended oil slowly through the filler point
 - 8.3. Replace the dipstick.
 - 8.4. Remove the dipstick.
 - 8.5. Check the oil level, if necessary add more oil.
 - 8.6. Replace the dipstick
 - 8.7. Replace the filler cap.

Replace

▲ CAUTION Oil will gush from the hole when the drain plug is removed. Keep to one side when you remove the plug.

CAUTION It is illegal to pollute drains, sewers or the ground. Clean up all spilt fluids and/or lubricants.

Used fluids and/or lubricants, filters and contaminated materials must be disposed of in accordance with local regulations. Use authorized waste disposal sites.

Figure 62.

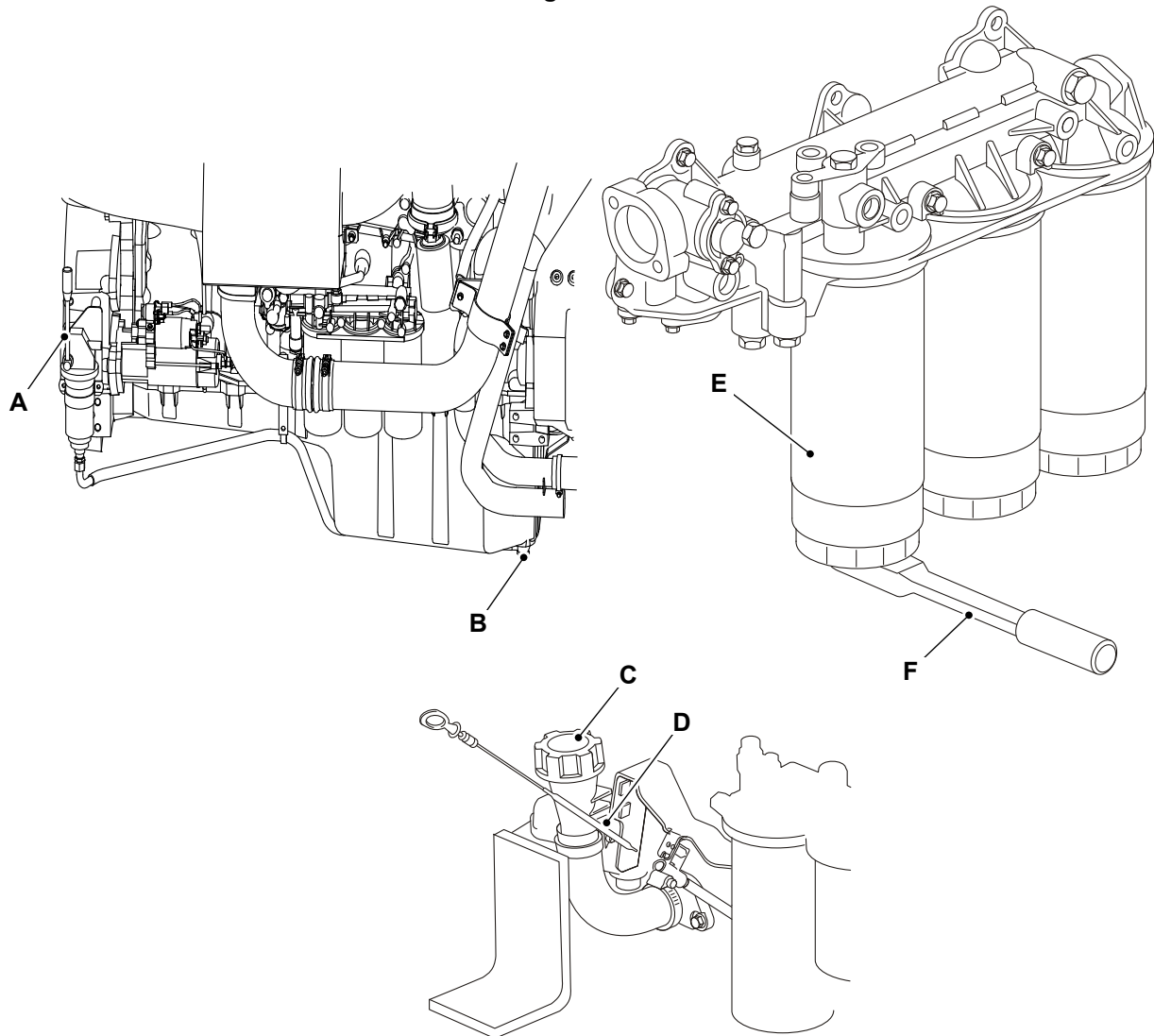

A Oil pump lever
C Oil filler point
E Oil filter (x3)

B Drain valve
D Oil level dipstick
F oil filter extractor

Drain the oil when the engine is warm as contaminants held in suspension will then be drained with the oil.

1. Make the machine safe.
2. Get access to the engine.
3. Remove the oil filler cap.
4. Make sure that drain valve is unlock.
5. Operate the oil pump lever and drain the oil into a suitable container.
6. Loosen and remove the filter housing drain plug. Fully drain the oil.
 - 6.1. Install the plug. Tighten the plug to the correct torque value.
7. Remove the oil filter with extractor, if necessary.
8. Clean the mating surface of the oil filter bracket.
9. Put a thin layer of engine oil on the seal rings of the new oil filters.

10. Install the new oil filters.
11. Fill the engine with the recommended oil to the MAX mark on the oil level dipstick through one of the oil filler points.
 - 11.1. Wipe off any spilt oil, install the filler cap and make sure it is secure.
12. Operate the engine until the oil pressure low warning light has extinguished.
13. Check for oil leakage.
14. When the oil has cooled, check the oil level again, and if necessary, fill with clean engine oil.

Front End Accessory Drive (FEAD) Belt

Check (Condition)

▲ CAUTION Make sure the engine cannot be started. Disconnect the battery before doing this job, otherwise you could be injured.

WARNING Do not try to turn the engine by pulling the fan or fan belt. This could cause injury or premature component failure.

Check

At the recommended service interval, visually inspect the belt for damage.

1. Stop the engine and let it cool down.
2. Isolate the machine and disconnect the battery.
3. Replace the FEAD (Front End Accessory Drive) belt if it has cracks or if it is frayed or has pieces of material missing. Refer to Figure 63.
4. If the belt does need replacing follow the procedures described below:

Figure 63.

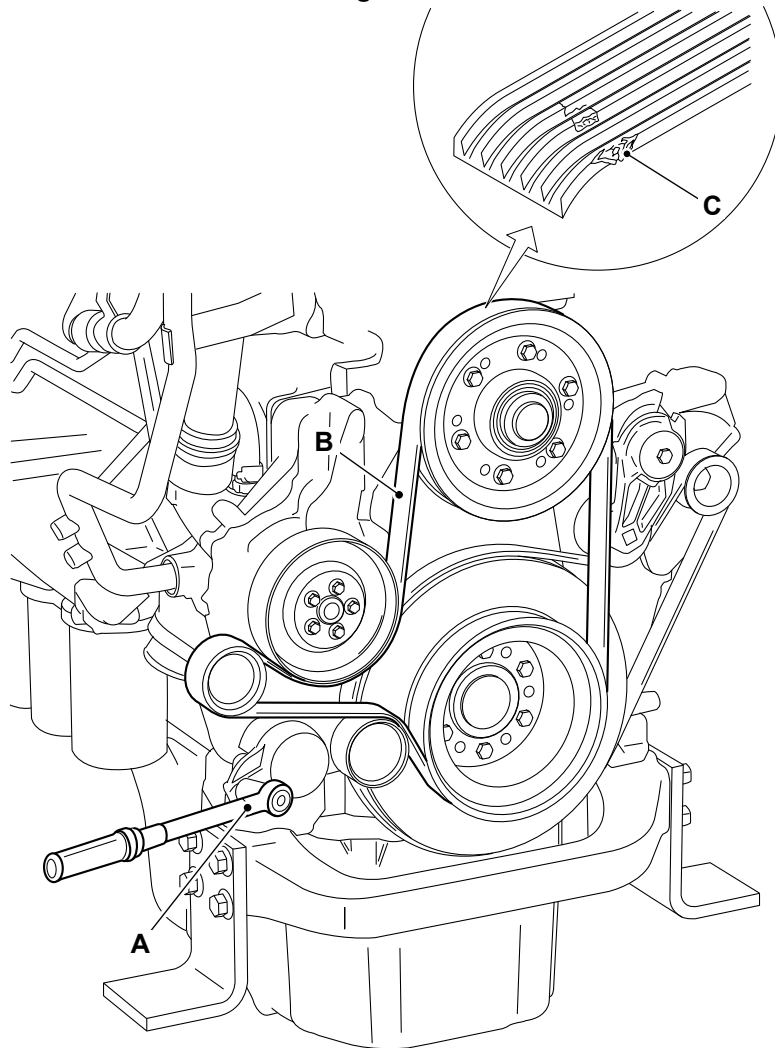

A Belt tensioner
C Belt material missing

B FEAD

Replacement

1. Stop the engine and let it cool down.
2. Isolate the machine and disconnect the battery.
3. Remove the fan guard and fan ring round the cooling fan.
4. Remove the belt guard.
5. Place a square wrench in the belt tensioner. Lift the wrench and remove the drive belt.
Torque: 3.2N·m (2.4lb.ft)
6. Thread the drive belt round the fan and remove it.
7. Check that the pulleys are clean and undamaged.
8. Thread the new drive belt over the fan.
9. Lift the wrench and install the new drive belt.
10. Install the belt guards.

11. Install the fan guard and fan ring round the cooling fan.
12. Start the engine and perform a function check.

Alternator

General

Safety Requirement

Before any cleaning, lubrication or maintenance operation, ensure that the generator is stationary and disconnected from the power supply.

When stopping the generator, ensure the compliance with the procedures for stopping the prime mover.

Starting and Stopping the Operations

The starting, running and stopping operations must be carried out by skilled personnel who have read and understood the safety instructions at the beginning of this manual.

Figure 64.

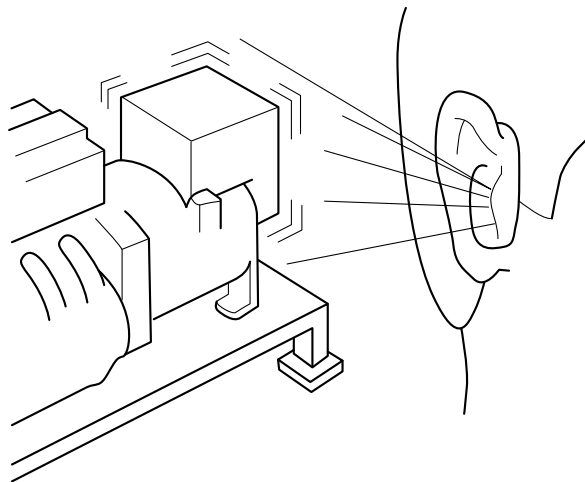

When the system is set to work for the first time the operator must check that no anomalous noises can be detected. If an anomalous noise is detected, stop the system immediately and contact your JCB Dealer

Maintenance

Before performing this operation, read the safety requirements at the beginning of this manual carefully.

Maintenance operations can be divided into routine and extraordinary specialist maintenance operations. In both cases, all operations must be authorized by the safety representative and they must be carried out when the machine is turned off and insulated from the electric installation or from the power mains.

Qualified mechanical or electrical technicians must carry out maintenance operations and any fault search since all operations described hereunder could put personnel in serious danger. It is also highly recommended to take all the necessary precautions so as to prevent an inadvertent starting of the machine during maintenance and fault search operations.

Routine maintenance operations can be done as follows:

- Assessment, on a regular basis, of correct functioning (absence of anomalous noises or vibrations).
- Mechanical inspections on all fastening bolts and, in particular, on electric connections.
- External cleaning of generator.

Internal and External Cleaning of the Generator

For the external cleaning of the generator, you can use compressed air. The use of dry-cleaners and detergent fluids is strictly forbidden. In the stationary condition the standard protection degree of the generator is IP21, therefore, use of fluids could cause anomalies or even short circuits.

Extraordinary maintenance operations can be summed up as follows:

1. Maintenance and replacement (if necessary) of bearings.
2. Assessment of windings condition after long periods of storage or inactivity.
3. Cleaning of windings.
4. Cleaning of air filters (if applicable).
5. Replacement of diode bridge.
6. Replacement of exciter.
7. Replacement of voltage regulator.
8. Check of residual voltage.

Clean

▲ Notice: Do not use water or any other liquid to clean the alternator.

Prior to approaching or touching the alternator, ensure that it is not live and it is at room temperature; at this stage it is possible to clean it on the inside and outside using compressed air.

Figure 65.

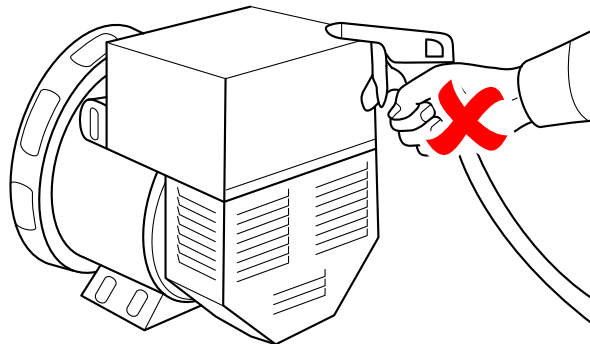

Emissions Control System

General

▲ Notice: Make sure that genuine Diesel Exhaust Fluid is used (DIN 70070 or ISO 22241 certified). Do not dilute DEF or mix it with other substances, it may damage the catalyst.

Notice: When filling the Diesel Exhaust Fluid tank, make sure that you use the DEF filler and not the fuel filler. Even small amounts of DEF in the fuel tank may damage the system. If there is any possibility that fuel has been contaminated with DEF, the engine must not be started before emptying and cleaning the fuel tank.

Notice: Supplementary admixtures or additives are not allowed. Do not dilute Diesel Exhaust Fluid or mix it with other substances as it may damage the catalyst. If the DEF quality sensor detects a problem, it will cause the engine to run at reduced power.

Notice: Be careful when handling Diesel Exhaust Fluid. It is aggressive to some materials and corrosive to some metals. DEF becomes crystalline when in contact with air. In case of a spillage, rinse with plenty of water and dry with a clean cloth.

Low Load Running

This machine should not be run at low load levels for extended periods of time: Alarms are activated if low load running persists.

The operator shall take every opportunity to check for low load operation by checking alarms and alarm logs. In the event of low load operation crystallization may occur within the exhaust system after the DEF (Diesel Exhaust Fluid) injector.

Urea crystal formations can develop when the engine experiences light constant operation, running less than 40% engine load, and lengthy periods of engine idling in excess of 2h.

Cool ambient temperatures will contribute to Urea crystal formation and any exhaust leaks or poor sealing will increase urea crystal development. The crystals will form just beyond the DEF injector and if the low load/low exhaust temperatures continue, the crystals will steadily grow to form a blockage inside the exhaust. High engine loading resulting in exhaust temperatures above 350°C (661.5°F) will cause the crystals to breakdown and clear.

As the crystals build, the operator will be notified if there is an issue with NOx (Nitrogen Oxide) conversion. The engine will transmit the fault code, SPN 4364 FMI 31. The description for this fault code is 'SCR (Selective Catalytic Reduction) NOx Catalyst efficiency' and will appear at the machine control panel before any de-rate occurs. It is at this point the machine needs to be worked hard to work the engine to raise exhaust temperatures and break down the crystals.

Myths and Facts about Crystallization

Myth- There should be no Urea crystals within the exhaust system.

Fact- All system which use DEF injection/SCR to control NOx will have Urea crystals form in the exhaust system post injector. Under normal operation the small Urea crystals build up will be burned off during higher load operation where the exhaust temperature is in excess of 350°C (661.5°F), this small build up will not have any impact on engine performance

Myth- Exhaust leaks are only present if there is soot leaking from the joint.

Fact- Poor exhaust joint sealing can cause air to be drawn into the exhaust system without leaking, this will cause hot exhaust gases to cool and Urea crystals to precipitate out of hot exhaust gases

Myth- Crystallization leaking out of a joint is always the result of DEF fluid overdosing.

Fact- DEF injection is a function of engine load and temperature, when the engine reaches a defined operating temperature DEF injection will initiate and continue to do so whilst monitoring NOx outlet temperatures.

Load Definitions - Percentage of load for 250kW engine

Low Load - 20% to 40% load - high risk of crystallization and exhaust pipe blockage forming.

Normal operation load - 50% to 70 % load - crystallization present but not building up.

High Load - 80% to 100% load.

What can be done to reduce crystallization by the dealer or operator?

If exhaust joints are opened during maintenance, make sure these are assembled properly with new seals and clamps. Any heat insulation must be replaced correctly and undamaged. Ensure the operator is aware of fault code SPN 4364 FMI 31. If caught early enough, load the machine with high load for as long as possible to burn off any significant crystal build up. Use good quality DEF fluid which exceeds ISO 22241 standards.

Air Filter

General

Check (Condition)

The engine is equipped with electronic air filter indication.

1. Make the machine safe.
2. Get access to the air filter.
3. Check the system hoses for:
 - 3.1. Condition.
 - 3.2. Damage.
 - 3.3. Security.
4. Replace the system hoses if necessary.
5. No cleaning or re-use is permissible.

Replace

Do not attempt to wash or clean the elements.

The control unit provides an output signal which is announced as a warning on the instrument panel. The warning indicates a pressure drop in the air filter, which must be checked and replaced.

- Scrap the old contaminated filter and install new air filter.
- For operations in extremely dirty environments such as coal mines and rock crushing mills, additional filters (primary and secondary) must be used.

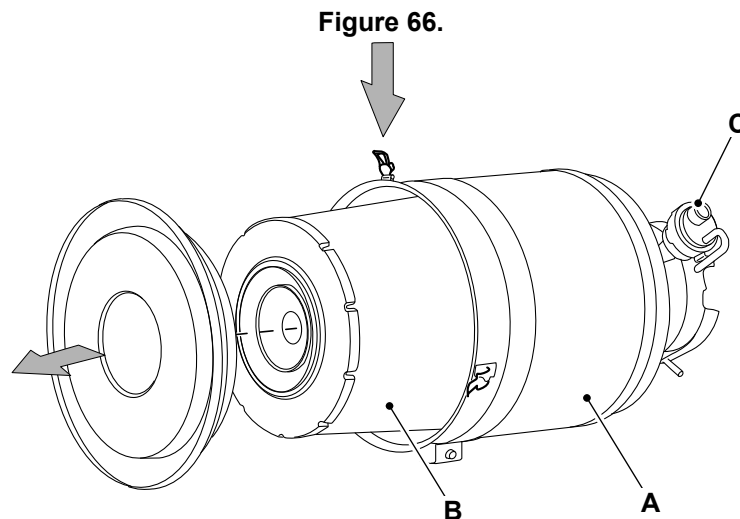

- A Air filter
- C Electronic blockage sensor

B Inner element

Dust Valve

Check (Condition)

- Check the dust valve for rips/tears.
- Check there are no obstructions.
- Check that the dust valve is free of dirt and dust.

- Check that the dust valve securely attached to the air filter housing.

Fuel System

General

Bleed

The system does not need to be purged unless it has been run completely dry. Purging is then done with the hand pump on the fuel filter bracket.

Check (Leaks)

1. Make the machine safe.
2. Get access to the engine compartment (if applicable).
3. Check the engine compartment (if applicable), fuel lines and the area below for leaks.
4. If necessary, contact your JCB dealer.

Primary Fuel Filter

Replace

▲ Notice: Do not allow dirt to enter the fuel system. Before disconnecting any part of the fuel system, thoroughly clean around the connection. When a component has been disconnected, for example a fuel pipe, always install protective caps and plugs to prevent dirt ingress. Failure to follow these instructions will lead to dirt entering the fuel system. Dirt in the fuel system will seriously damage the fuel injection equipment and could be expensive to repair.

1. Make the machine safe.
2. Get access to the fuel pre-filter.
3. Remove the cable from the water trap sensor.

Figure 67.

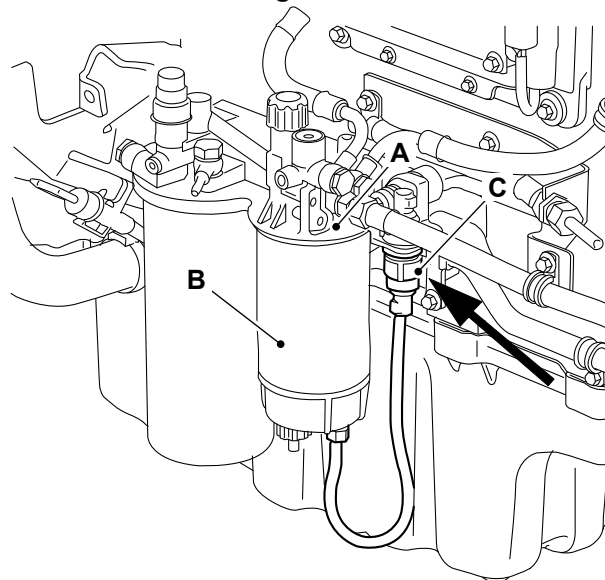

A Filter bracket
C water trap sensor

B Pre-filter

4. Remove the pre-filter from the filter bracket.

Figure 68.

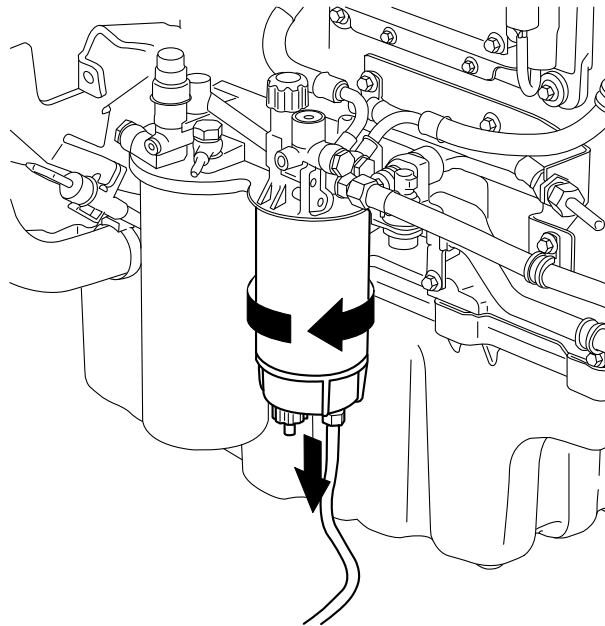

- 4.1. Put a container below the fuel pre-filter to collect the contaminated fuel.
5. Remove the lower part of the water trap from the filter.
6. Clean the lower part of the water trap with a soft rag.

Figure 69.



- 6.1. Check that the drain hole in the lower part is not blocked.
7. Lubricate the seal with clean diesel.
 - 7.1. Install the filter onto the filter bracket by hand until the rubber seal just touches the mating surface.
 - 7.2. Make sure that you tighten a further half turn, no more.
8. Connect the cable to the water trap sensor.
9. If necessary, bleed the fuel system.

[Refer to: General \(Page 90\).](#)

Secondary Fuel Filter

Replace

▲ Notice: Do not allow dirt to enter the fuel system. Before disconnecting any part of the fuel system, thoroughly clean around the connection. When a component has been disconnected, for example a fuel pipe, always install protective caps and plugs to prevent dirt ingress. Failure to follow these instructions will lead to dirt entering the fuel system. Dirt in the fuel system will seriously damage the fuel injection equipment and could be expensive to repair.

Fuel filter must be replaced while the engine is in cold condition.

Do not fill the new fuel filter with fuel before assembly. There is a risk that contamination could get into the system and cause malfunctions or damage.

1. Make the machine safe
2. Get access to the filter.
3. Clean round the fuel filter.
4. Remove the fuel filter with a suitable filter remover.
 - 4.1. Put a container below the fuel pre-filter to collect the contaminated fuel.
5. Clean the filter mating surface on the filter bracket.
6. Lubricate the seal with diesel fuel and install the new fuel filter.
 - 6.1. If necessary, bleed the fuel system.
7. If a water trap is installed, change the filter in it at the same time as the fuel filter, and clean the water trap in the plastic bowl under the filter with a soft rag.

Cooling System

General

Check (Leaks)

Before you start the engine, inspect the system for leaks:

1. Make the machine safe.
2. Get access to the cooling pack.
3. Check the cooling system for leaks.
4. If necessary, contact your JCB dealer.

Coolant

Check (Condition)

Refer to: [Coolant \(Page 108\)](#).

Check (Level)

1. Make the machine safe.
2. Let the engine cool.
3. Get access to the radiator filler cap and expansion bottle.

CAUTION! The cooling system is pressurized when the coolant is hot. When you remove the cap, hot coolant can spray out and burn you. Make sure that the engine is cool before you work on the cooling system.

4. Check the level of coolant in the radiator and in the expansion bottle. If necessary, top-up the system:
 - 4.1. Carefully remove the filler cap.
 - 4.2. If necessary top-up the coolant to the neck of the expansion tube.
 - 4.3. If necessary top-up the coolant in the expansion bottle so that it is half full.
 - 4.4. Install the filler cap, make sure that it is tight.

Cooling Pack

Clean

1. Make the machine safe.
2. Let the engine cool.
3. Get access to the cooling pack.
4. If necessary, use a soft bristle brush or compressed air to remove all debris from the cooling pack.

Check (Condition)

1. Make the machine safe.
2. Let the engine cool.
3. Get access to the radiator.
4. Check the condition of the coolant hoses.

5. Check the radiator and intercooler surfaces for signs of damage.
6. If necessary, contact your JCB dealer for any service requirements.

Wheels

General

Check (Condition)

▲ WARNING A raised and badly supported machine can fall on you. Position the machine on a firm, level surface before raising one end. Ensure the other end is securely chocked. Do not rely solely on the machine hydraulics or jacks to support the machine when working under it. Disconnect the battery, to prevent the machine being started while you are beneath it.

WARNING Walking or working under raised attachments can be hazardous. You could be crushed by the attachments or get caught in the linkages. Lower the attachments to the ground before doing these checks. Also make sure that the park brake is engaged before doing these checks.

WARNING Whenever a wheel has been changed, check the nut torques every two hours. When the nuts stay tight for 8 h, the interval for checking can revert to the period stated in the servicing schedule.

WARNING A machine can roll off jacks and crush you unless the wheels have been blocked. Always block the wheels at the opposite end of the machine that is to be jacked. Do not work underneath a machine supported only by jacks. Always support a jacked-up machine on axle stands before working underneath it.

WARNING Wheels and tires are heavy. Take care when lifting or moving them. Store with care to ensure that they cannot fall and cause injury. Use suitable lifting equipment if necessary.

Changing a Wheel

If for whatever reason a wheel bolt is renewed, all the bolts for that wheel must be replaced as a set, since the remaining bolts may have been damaged.

Remove

1. Make the machine safe.
[Refer to: Maintenance Positions \(Page 78\).](#)
2. Jack up the machine to gain access to whichever wheel you wish to change.
3. Remove the nuts then remove the wheel

Replace

1. Inspect the wheel for any damage, i.e. elongated holes.
2. Clean the hub, wheel mounting face and nut cones thoroughly if they are contaminated with paint, rust or debris.
3. Ensure the wheel stud thread surface is maintained dry and is free from all lubricants.
4. Position the wheel on the hub.
5. Lightly tighten the nuts to ensure the wheel is correctly seated onto the hub.
6. Tighten the nuts in the sequence shown.

Figure 70.

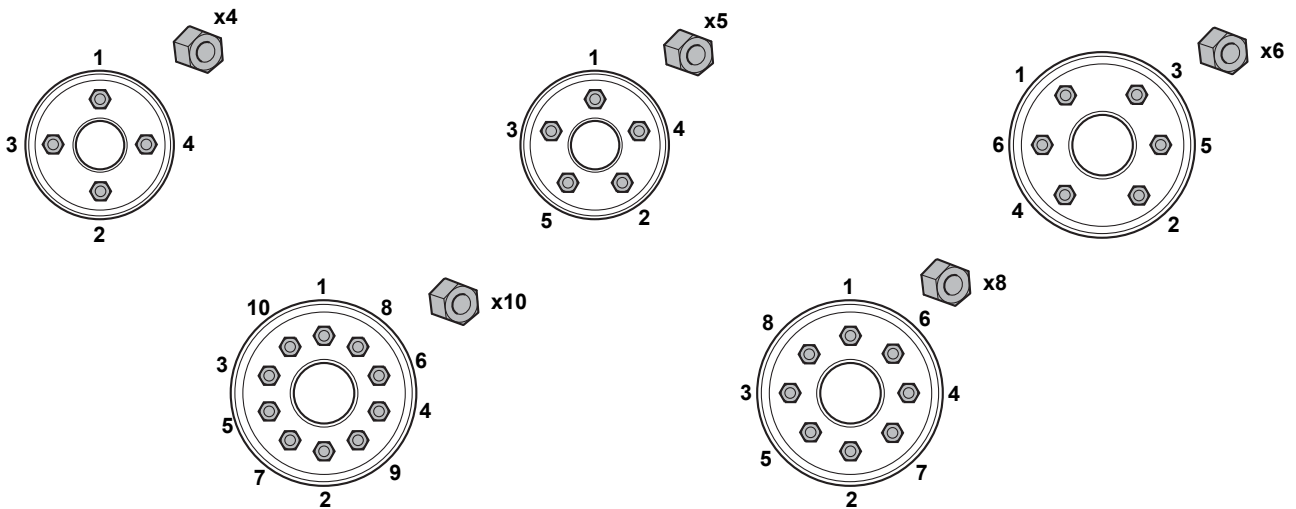

7. Lower the machine to the ground.
8. Torque tighten the nuts in the sequence shown.

[Refer to: Torque Values \(Page 109\).](#)

Checking the Wheel Nut Torques

▲ WARNING If, for whatever reason, a wheel stud is renewed, all the studs for that wheel must be changed as a set, since the remaining studs may have been damaged.

On new machines, and whenever a wheel has been removed, check the wheel nut torques every two hours until they stay correct.

Every day, before starting work, check that the wheel nuts are tight.

[Refer to: Torque Values \(Page 109\).](#)

Tires

General

Check (Condition)

▲ WARNING Do not use the machine with damaged, incorrectly installed, incorrectly inflated or excessively worn tires. Recognize the speed limitation of the tires installed and do not operate at more than their recommended maximum speed.

WARNING An exploding tire can kill. Inflated tires can explode if over-heated or over-inflated. Follow the instructions given when inflating the tires. Do not cut or weld the rims. Use a tire/wheel specialist for all repair work.

WARNING Wheels and tires are heavy. Take care when lifting or moving them. Store with care to ensure that they cannot fall and cause injury. Use suitable lifting equipment if necessary.

Checking the Tire Condition

Always drive with consideration for the condition of the tires. Incorrect tire pressures will affect the stability of the machine. Check the tires daily for the correct tire pressure and signs of damage. For example:

- Signs of distortion (bulges)
- Cuts or wear
- Embedded objects (nails, etc.)

Install the valve caps firmly to prevent dirt from entering the valve. Inspect for leaks when you check the tire pressures.

Inspect the tire valve for leaks, when you check the tire pressures.

Tire Inflation

Always try to maintain your tire pressure to the recommended settings. Using your machine with under-inflated tires means:

- Decreasing the machines stability
- Higher tire temperatures
- Excessive strain of the tire fabric
- More bulging of the sidewalls
- Shortens the tires life.

Using the machine with over-inflated tires is dangerous:

- It causes excessive tensile loads in the fabric: this makes a tire more susceptible to cuts and punctures.

Do not cut or weld on the rim of an inflated tire.

Always deflate the tire before removing foreign obstacles from the tread.

Always check the tire pressures with the machine in an unladen state.

After checking or amending the tire pressure always replace and secure the valve cap.

Under special conditions (e.g. on sand) the air pressure in the tire may be reduced after you have consulted your JCB dealer or tire manufacturer.

Electrical System

General

Check (Condition)

Examine the electrical circuits regularly for:

- Damaged connectors
- Loose connections
- Chafing on the wiring harnesses
- Corrosion
- Missing insulation
- Incorrect routing of the wiring harnesses.

Do not use the machine if one or more of these faults are found. You must make sure that the electrical circuit is repaired immediately.

Battery

Clean

▲ WARNING Keep metal watch straps and any metal fasteners on your clothes, clear of the positive (+) battery terminal. Such items can short between the terminal and nearby metal work. If it happens you can get burned.

1. Make the machine safe.
2. Get access to the battery.
3. If the terminal posts are corroded and covered with white powder wash them with hot water. If there is considerable corrosion, clean the terminal posts with a wire brush or abrasive paper. Refer to Figure 71.

Figure 71.

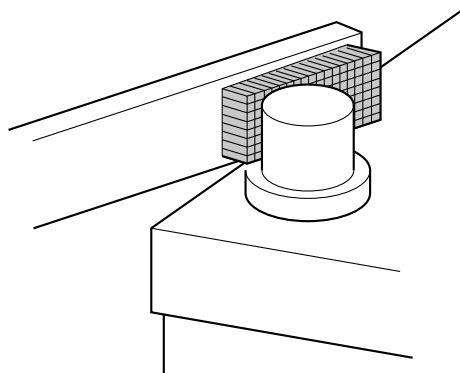

4. Apply a thin layer of petroleum jelly to the terminal posts.

Connect

▲ WARNING Keep metal watch straps and any metal fasteners on your clothes, clear of the positive (+) battery terminal. Such items can short between the terminal and nearby metal work. If it happens you can get burned.

CAUTION The machine is negatively earthed. Always connect the negative pole of the battery to earth.

When connecting the battery, connect the earth (-) lead last.

When disconnecting the battery, disconnect the earth (-) lead first.

CAUTION Understand the electrical circuit before connecting or disconnecting an electrical component. A wrong connection can cause injury and/or damage.

1. Get access to the batteries.
[Refer to: Disconnect \(Page 99\).](#)
2. Connect the battery leads. Connect the earth (-) terminal last.
3. If the machine has a battery isolator, move the switch to the on position.

Disconnect

▲ WARNING Keep metal watch straps and any metal fasteners on your clothes, clear of the positive (+) battery terminal. Such items can short between the terminal and nearby metal work. If it happens you can get burned.

CAUTION The machine is negatively earthed. Always connect the negative pole of the battery to earth.

When connecting the battery, connect the earth (-) lead last.

When disconnecting the battery, disconnect the earth (-) lead first.

CAUTION Understand the electrical circuit before connecting or disconnecting an electrical component. A wrong connection can cause injury and/or damage.

Notice: Do not disconnect the battery while the engine is running, otherwise the electrical circuits may be damaged.

1. Make the machine safe.
[Refer to: Maintenance Positions \(Page 78\).](#)
2. Get access to the batteries.
[Refer to: Access Apertures \(Page 79\).](#)
3. If the machine has a battery isolator, switch off the battery isolator and remove the key.
[Refer to: Battery Isolator \(Page 17\).](#)
4. Disconnect the battery leads. Disconnect the earth (-) terminal first.

Check (Electrolyte Level)

Electrolyte Level

▲ WARNING Do not top the battery up with acid. The electrolyte could boil out and burn you.

Maintenance free batteries used in normal temperate climate applications should not need topping up. However, in certain conditions (such as prolonged operation at tropical temperatures or if the alternator overcharges) the electrolyte level should be checked as described below.

1. Get access to the battery.
2. Disconnect and remove the battery.
3. Remove the service plugs. Look at the level in each cell. The electrolyte should be 6 mm (1/4 in) above the plates. Top up if necessary with distilled water or de-ionized water.
4. Install the battery.

Check (State of Charge)

▲ DANGER If you try to charge a frozen battery, the battery could explode. Do not use a battery if its electrolyte is frozen. To prevent the battery electrolyte from freezing, keep the battery at full charge.

DANGER Batteries give off explosive gases. Keep flames and sparks away from the battery. Do not smoke close to the battery. Make sure there is good ventilation in closed areas where batteries are being used or charged. Do not check the battery charge by shorting the terminals with metal. Use a hydrometer or voltmeter.

CAUTION The machine is negatively earthed. Always connect the negative pole of the battery to earth.

When connecting the battery, connect the earth (-) lead last.

When disconnecting the battery, disconnect the earth (-) lead first.

Charging the Battery

If the battery voltage is below 12.4V in a 12V system, or 24.5V in a 24V system the engine cranking speed may not be sufficient to start the engine, charging may be required..

If the generating set has an on board battery charger this will take care of charging when connected to the auxiliary mains supply. If a charger is not fitted, the recommended charging within 1/10 of the normal capacity for 5–6h must be carried out by connecting an external charger.

If using the onboard battery charger the charge current will be controlled by the unit, and reduced accordingly when the battery is fully charged. At this point the battery charger will switch to trickle charge, maintaining the battery in a fully charged condition.

Battery Maintenance

Under normal conditions no topping up is required. However in case of high number of starts, or high operating temperatures topping up may be required: use only demineralized water; never add sulfuric acid.

Battery Life

The control panel, remote communication (if installed) and other stand-by functions, provide some drain on the battery. JCB recommend that wherever possible an auxiliary battery charger is fitted. This charger will provide a maintenance charge to the system batteries allowing for optimum system performance whenever start-up signal is received. The auxiliary battery charger requires an external supply, therefore installation of this unit is not possible in all applications.

Where it is not possible to have an auxiliary battery charger installed, JCB recommend a running cycle of 1–2h twice weekly. This exercising of the Generator Set recuperates the battery utilizing the charging alternator, and allows the machine to maintain a healthy stand-by state.

If operating where the ambient temperature could drop below -15°C (5.0°F) remove the battery at the end of the day and store in a warm place until required again. This will help to start the engine easily or install heating pads and/or a battery charger if possible.

Do not jump start the battery on the generator, replace or recharge the battery as an alternative. Jump start can create a surge of high voltage. This will cause catastrophic failure of the electronics component fitted in the control system and engine. This failure is deemed as non-warrantable, as a result of bad practice.



Static Dimensions

Dimensions

Table 37. Dimensions - Static

Length	Width	Height
195 in	81 in	100 in

Table 38. Dimensions with Trailer

Length	Width	Height
261 in	105 in	123 in

Weights

Table 39. Weight - Static

Weight ⁽¹⁾	21772 lbs
-----------------------	-----------

(1) Standard build with all fluids including fuel

Table 40. Weight with Trailer

Weight ⁽¹⁾	24472 lbs
-----------------------	-----------

(1) Standard build with all fluids including fuel



Noise Emissions

Noise Data

Table 41.

LpA 7m (7½yd)	60Hz	72 dB(A)
---------------	------	----------



Fluids, Lubricants and Capacities

General

The generating set engine oil is pre-filled in factory. However it is important to check the level of oil in the engine before any starting can take place, and also as part of a regular maintenance schedule.

New engines do not require a running-in period. The engine/machine should be used in a normal work cycle immediately, glazing of the piston cylinder bores, resulting in excessive oil consumption, could occur if the engine is gently run-in. Under no circumstances should the engine be allowed to idle for extended periods; (e.g. warming up without load).

Important: Operation of the engine with some types of fuel requires use of superior grade oil.

Superior grade oils may be more appropriate for heavy duty applications (such as sustained high loads and operation at elevated temperatures).

The choice of lubricant viscosity should be made based on the lowest ambient temperature at which the machine will be started and the maximum ambient temperature at which it will operate.

Important: When selecting the oil viscosity grade make sure the oil conforms with or exceeds the recommended specification.

Recommended Oils

Table 42.

Item	Capacity	Fluid/Lubricant	JCB Part Number	Container Size	Specification
Engine Oil	12.70 US gallons	JCB Ultra Performance 5W40	4001/3405U	5 US gallons	API CH4
Cooling System	12.70 US gallons	VCS OAT coolant pre-mix			
Fuel tank	593 US gallons	Diesel oil			ASTM D975 (2D)
DEF (Diesel Exhaust Fluid) tank	42.3 US gallons	DEF			ISO 22241-1

Fuel

Acceptable and Unacceptable Fuels

▲ WARNING Do not use gas in this machine. Do not mix gas with the diesel fuel. In storage tanks the gas will form flammable vapors.

Notice: No warranty liability whatsoever will be accepted for failure of fuel injection equipment where the failure is attributed to the quality and grade of the fuel used.

Notice: Sulfur can be detrimental to the emissions performance of your engine and it is in your interest to ensure Ultra Low Sulfur Diesel (ULSD) is used. Failure to adhere to local emissions regulations will result in no support and no warranty liability being accepted on any engine.

Fuel Groups

The major world fuels standards are divided into four categories. Those that are fully accepted as suitable fuels, those that are acceptable from a "warranty" point of view, but may have undesirable affects on the expected life of the engine performance, those that will reduce the expected life, and lastly those that are viewed as unacceptable for use (fuels shown on the same line as each other are considered equivalents).

The lists below are not exhaustive of all diesel fuel standards encountered in the marketplace. If comment is required on the suitability of fuel standards not on the list, requests with, if possible, specification details showing at least the key characteristics described above should be forwarded to JCB Service for assessment and comment.

Table 43. Group 1

Fuel	Advice	Service Requirements
EN590 Diesel fuel types - Auto/C0/C1/C2/C3/C4 Sulfur < 10ppm.	Preferred and may be used with no restrictions or conditions.	For fuel with unspecified parameters, EN590 values apply. Fuel grades within each standard must be appropriate to the ambient temperature. The appropriate level of fuel cleanliness at the FIE inlet after filtration has to be ensured by the customer.
BS2869 Class A2 Sulfur < 10ppm		
ASTM D975-076 2-D, US DF1, US DF2, US DFA Sulfur < 15ppm		
JIS K2204 Grades 1, 2, 3 and Special Grade 3 Sulfur < 10ppm		

Table 44. Group 2

Fuel	Advice	Service Requirements
Group1 fuels with HFFR WSD in the range 460 (18,110) to 520 (20,472½)	Not preferred and may be used but may lead to reduced FIE life and / or loss of performance.	
ASTM D975-91 Class 1-1DA		

(1) See your JCB dealer for advice on service requirements.

Table 45. Group 3

Fuel	Advice
AVTUR FS11 (NATO F34, JP8, MIL T83133, DEF STAN 91-87, DERD 2463)	Not preferred and may be used only with appropriate additives and will lead to reduced FIE life and / or loss of performance.
AVCAT FS11 (NATO F44, JP5, MIL T5624, DERD 2452, AVTOR))	
JET A1 (NATO F35, DEF STAN 91-91, DERD 2494)	
AVCAT (NATO F43, JP5 without additives)	
JET A (ASTM D1655)	
ASTM D3699 Kerosene	
JP7 (MIL T38219 XF63)	
NATO F63	

Table 46. Group 4

Fuel	Advice
Unmodified Vegetable Oils and Biodiesels over 20% concentration	Unacceptable

Additives

The additives listed below are advertised as being suitable for bringing the lubricity levels of kerosene/low sulfur fuels up to those of diesel fuels.

These products are given as examples only. The information is derived from the manufacturer's data. The products are not recommended or endorsed by JCB. Contact your JCB dealer for further advice.

- Elf 2S 1750. Dosage 1000-1500 ppm (0.1% to 0.15%), specifically for Indian Superior Kerosene (SKO) but may be applicable to other fuels.
- Lubrizol 539N. Dosage (on Swedish low sulfur fuel) 250 ppm.
- Paradyne 7505 (from Infineum). Dosage 500 ppm (0.05%).

Warranty

JCB have shown a commitment to support the environment by approving the use of biodiesel blended fuels.

Using a B5 blend of biodiesel requires caution and additional servicing of the engine is required.

Failure to follow the additional recommended service requirements may lead to a warranty claim being declined.

Failures resulting by the incorrect use of biodiesels or other fuel additives are not defects of the engine workmanship and therefore will not be supported by JCB Warranty.

Usage and Effects of Fuels

The information that follows indicates types of fuel that are acceptable or unacceptable.

Acceptable Fuels

Ultra Low Sulfur Diesel (EN590)

Available throughout the UK, Europe and North America since March 1999. This fuel has a maximum sulfur content of 0.001% (0.0015% in North America) by weight and a further reduction in the natural lubricity and aromatic content than experienced with low sulfur diesel. Major oil producers will add lubrication improvers and also maintain the total aromatic content to an acceptable level.

Unacceptable Fuels

B20 Biodiesel

Biodiesel refers to pure fuel before it is blended with diesel fuel. When biodiesel is blended with diesel fuel it is referred to as B5, B20 etc., where the number indicates the percentage of biodiesel in the fuel, for example B5 contains 5% biodiesel.

Biodiesel has different characteristics than mineral based fuels, this could lead to seals swelling, fuel system corrosion and seal damage.

Using B20 biodiesel can result in poisoning of the SCR (Selective Catalytic Reduction) system.

The natural properties of biodiesel make it a good medium for micro bacterial growth, these microbes can cause fuel system corrosion and early fuel filter blocking.

B100 - Chemically Modified Vegetable Oils (FAME/ VOME)

These fuels have been derived from a wide range of vegetable oils and animal fats, resulting in better stability, viscosity and cetane number than those produced from unmodified vegetable oils, but it is recognized that there are potential problems associated with the finished fuel characteristics. These oils are less stable than mineral oil derived fuels when stored and they will readily degrade producing fatty acids, methanol and water, none of which are desirable in the FIE. These effects are known to be accelerated when the fuel is stored in the presence of air and water together.

An extract 'common statement' from the FIE manufactures specifies that "The fuel injection equipment manufacturers can accept no liability whatsoever for failure attributable to operating their products with fuels for which the products were not designed, and no warranties or representations are made as to the possible effects of running these products with such fuels".

Unmodified Vegetable Oils

Burned in diesel engines neat or used as an extender to mineral derived fuel. When these are subjected to heat in the fuel injection system they form sticky deposits that can be found inside the fuel pump and a hard lacquer in the injectors where exposure to even higher temperatures takes place.

Sulfur Content

▲ **Notice:** A combination of water and sulfur will have a corrosive chemical effect on fuel injection equipment. Use of high Sulfur fuels will poison the Selective Catalytic Reduction (SCR) catalyst (if fitted) and must not be used. Ultra Low Sulfur Diesel (ULSD) should always be used. Ultra Low Sulfur Diesel (ULSD) has a Sulfur content of less than 10 ppm (US 15ppm).

Effects of Fuel Contaminates

The effect of dirt, water and other contaminants in diesel can be disastrous for injection equipment:

Dirt

A severely damaging contaminant. Finely machined and mated surfaces such as delivery valves and distributor rotors are susceptible to the abrasive nature of dirt particles - increased wear will almost inevitably lead to greater leakage, uneven running and poor fuel delivery.

Water

Water can enter fuel through poor storage or careless handling, and will almost inevitably condense in fuel tanks. The smallest amounts of water can result in effects that are just as disastrous to the fuel injection pump as dirt, causing rapid wear, corrosion and in severe cases, even seizure. It is vitally important that water is prevented from reaching the fuel injection equipment. The filter/water trap must be drained regularly.

Wax

Wax is precipitated from diesel when the ambient temperature falls below that of the fuel's cloud point, causing a restriction in fuel flow resulting in rough engine running. Special winter fuels may be available for engine operation at temperatures below 0°C (32.0°F). These fuels have a lower viscosity and limit wax formation.

Chemical Contamination

It should be noted that exposure of fuel to surfaces containing Copper (Cu), Zinc (Zn) or Lead (Pb) can adversely affect fuel quality and should be minimized.

JCB Power Systems - Use of HVO Fuels

Following market requests from JCB power systems customers to approve the use of HVO (hydro-treated vegetable oil) fuel as a diesel fuel alternative in JCB engines. JCB power systems have carried out extensive testing to make sure that this has no detrimental effect on the performance and reliability of the JCB engine.

JCB power systems confirm that HVO has been tested and approved for use with JCB 444 and 448, stage IIIB and stage IV engines. The testing has been conducted by JCB power systems and this approval does not constitute any recertification of any engine model by any third party notified body.

The JCB 444/448 engines can be operated on HVO or 'synthetic' fuels as long as these fuels meet EN15940 and any other local emissions legislation. Customers should note that engine performance may be lower than regular diesel due to the characteristics of HVO fuel. Customers make sure that any additional maintenance requirements, including but not limited to servicing periods, are identified to users.

Diesel Exhaust Fluid (DEF)

▲ Notice: No warranty liability whatsoever will be accepted for failure of the emissions control system where the failure is attributed to the quality and grade of the diesel exhaust fluid (DEF) used.

Notice: No warranty liability whatsoever will be accepted for failure of the emissions control system where the failure is attributed to contamination of the diesel exhaust fluid (DEF).

This engine has exhaust gas treatment using selective catalytic reduction technology. In SCR (Selective Catalytic Reduction) technology, a liquid called diesel exhaust fluid is injected into the exhaust gasses. DEF (Diesel Exhaust Fluid) is used within SCR systems on diesel engines to reduce harmful exhaust gas emissions known as NOx. When the DEF is injected into the exhaust stream it turns into ammonia and water, this ammonia enters the catalyst and reacts with the NOx molecules to form nitrogen and water. Naturally occurring and harmless, they are then released into the atmosphere.

The DEF consumption depends on the duty cycle of the engine.

DEF is a highly purified, colorless liquid containing demineralized water 67.5% and Urea 32.5%. DEF is specified under ISO 22241 and is marketed under various names such as AdBlue®, ARLA 32 or AUS 32.

Make sure that genuine DEF is used. Do not dilute DEF or mix it with other substances, it may damage the catalyst.

The DEF tanks and pipes are heated if there is any danger of freezing, the freezing point of DEF at 32.5% is -11°C (12.2°F). The DEF storage tank on the machine will be heated from the engine cooling system automatically.

If a problem is detected within the DEF system for any problem including contamination, engine power will be reduced.

Storage

Always use polyethylene, polypropylene, stainless steel or plastic containers for storing DEF, as DEF can be corrosive to most metals (eg steel, copper, and aluminium). This applies to any funnels, jugs, pipes, pumps and other handling equipment

Avoid decanting wherever possible to prevent contamination from dirt or trace amounts of metals that can occur when metal containers are used. Even the use of apparently clean items such as jugs or funnels may introduce damaging contaminants if they have ever been used for other purposes.

Always ensure any caps on DEF storage containers are screwed tight to prevent evaporation and crystallization.

DEF can be stored for up to 12 months in a sealed container, and must be kept between -6°C (21°F) and 25°C (77°F) in a shaded area out of direct sunlight and ultraviolet radiation.

Spillages

A small DEF spill can be diluted with water. It is best to mop up the spillage and avoid flushing it down a drain or waterway

In case of a large spill, try to prevent the spillage from entering drains or waterways. Contain the spill with sand, earth or your spill kit and dispose of it properly

The surface on which you spill DEF may become slippery. Make sure that you clean up the spill as quickly as possible to prevent slips and falls.

If a spill occurs on the machine, wash away with water as white crystals will form and these will eventually become corrosive to paintwork and, in turn, metal work

DEF should never be spilled onto electrical connectors as it will destroy terminals quickly. It can also travel easily by capillary action between the insulation and copper wires in harnesses.

Preventing Contamination of the DEF tank

In order to prevent damage to the SCR system, DEF used must be compliant to the ISO 22241-1 standard. ISO 22241-1 DEF is available from all JCB dealers

Every machine equipped with a JCB SCR system is fitted with a quality sensor in the DEF tank to help prevent problems caused by cross contamination with other fluids

DEF needs to be kept free from dirt and other particle contaminants at all times to prevent damage to the SCR system. There is a mesh strainer fitted in the JCB DEF filler.

DEF needs to be kept free from liquid contaminants such as diesel, oil, antifreeze, screenwash and other fluids at all times. Even one drop of diesel or oil can pollute 20L (4UKgal) of DEF.

If diesel is poured into the DEF tank this can damage the after treatment system, do not start the engine, please contact your local JCB dealer immediately so they can correctly flush the system to avoid an expensive repair.

A range of special tools and fluid analysis services are available at your local JCB dealer to check DEF quality via simple hydrocarbon test paper strips, or a more comprehensive laboratory service. Digital and optical concentration measuring devices are also available.

If any cross contamination is detected JCB will not be liable for any further diagnosis or repairs to the SCR system.

Preventing Cross Contamination of Diesel Fuel and DEF

The opening for your DEF tank is narrower than the opening for a diesel tank, so you should not be able to put diesel in the wrong tank (as the nozzle does not fit)

The DEF cap on every JCB machine is blue and clearly marked with AdBlue®, DEF and the ISO (International Organization for Standardization) symbol in white lettering. There are warning decals next to the DEF filling point

The diesel cap is also clearly marked with lettering.

Every JCB DEF cap is lockable with a special key with a blue key fob, which can be given to a site supervisor or other person of responsibility.

There is a special magnet fitted in the DEF filler neck which will allow some DEF electric dispensing pumps to start if it has the matching ISO feature, as all forecourt dispensing systems have, thus preventing DEF being dispensed if nozzle is not in the DEF tank.

If contamination occurs do not start the engine. Please contact your local JCB dealer immediately so they can correctly flush the system to avoid an expensive repair.

Coolant

Coolant Mixtures

Use the coolant specified in this manual. Different types of coolants must not be used or mixed. [Refer to: General \(Page 103\).](#)

Volvo Penta Coolant VCS (yellow) and Volvo Penta Coolant (green) are two completely different types of coolants, which contain different types of inhibitors. Different types of coolants (colors) must not be mixed. If the concentrated coolant must be diluted with water, the water's chemical composition may impair the corrosion protection. In areas with high levels of sodium and calcium in tap water, the coolant must be diluted with distilled water. Alternatively, Volvo Penta coolant is available for purchase ready diluted.

Check the strength of the coolant mixture at least once a year, preferably at the start of the cold period. Do not use solutions of more than 60% or damage to the engine may occur. Replace the coolant mixture according to the intervals shown in the machine's maintenance schedule.

Table 47.

Solution	Protection against freeze bursting down to:
40% Concentration	-25°C (-13.0°F)
460% Concentration	-30°C (-22.0°F)
54% Concentration	-38°C (-36.3°F)
60% Concentration	-46°C (-50.7°F)

Torque Values

General

On first trip tighten wheel lugs at start and at 16km (10mi), 40km (25mi) and 80km (50mi). Thereafter, check wheel lugs before each trip, after excessive braking and following long periods of non-use.

Table 48.

Item	Torque
Trailers with 5 or 6 wheel nuts	136N·m (100lb.ft.)
Trailers with 8 wheel nuts	163N·m (120lb.ft.)

Electrical System

General

Table 49.

Multi Switch Position	3	2	1
Frequency	60Hz	60Hz	60Hz
Phases	1	3	3
Output Voltage	240V/120V	208V/120V	480V/277V
Prime	300kW (402.1hp) kW 300kVA	500kW (670.2hp) 625kVA	500kW (670.2hp) 625kVA
Amps	1,250A	1,290A A	753A
Power factor	1	0.8	0.8
Rated speed	1800 RPM (Revolutions Per Minute)	1800 RPM	1800 RPM
Alternator	ECO40-1.5L/4B	ECO40-1.5L/4B	ECO40-1.5L/4B
Alternator Maximum In- stantaneous Fault Current	16,523A	16,523A	16,523A
Breaker	1,600A/2,000A	1,600A/2,000A	1,600A/2,000A
Sensor Plug	1,600A/2,000A	1,600A/2,000A	1,600A/2,000A
Overcurrent protection (I _r)	1,250A	1,735A	752A
Short circuit protection (I _{sd})	3,750A	5,210A	2,260A
Instantaneous current setting (I _i)	4,800A/4,000A	6,400A/6,000A	3,200A/4,000A
Overcurrent protection time setting (t _r)	1s	1s	1s
Short circuit time delay (t _{sd})	0s	0s	0s

Prime: This rating is for the supply of continuous electrical power, at variable load (70% average), in lieu of commercially purchase power. There is no limitation on the annual hours of operation and 10% over load power can be supplied for 1h in 12h.

Standby: Standby Power (ESP (Emergency Standby Power)) is the maximum output available, for up to 200h per year, where the average load (variable) does not exceed 70% of the standby power rating. No overload is available.

Schematic Circuit

Figure 72. 401/G9343 - Issue 1 (Sheet 1 of 1)

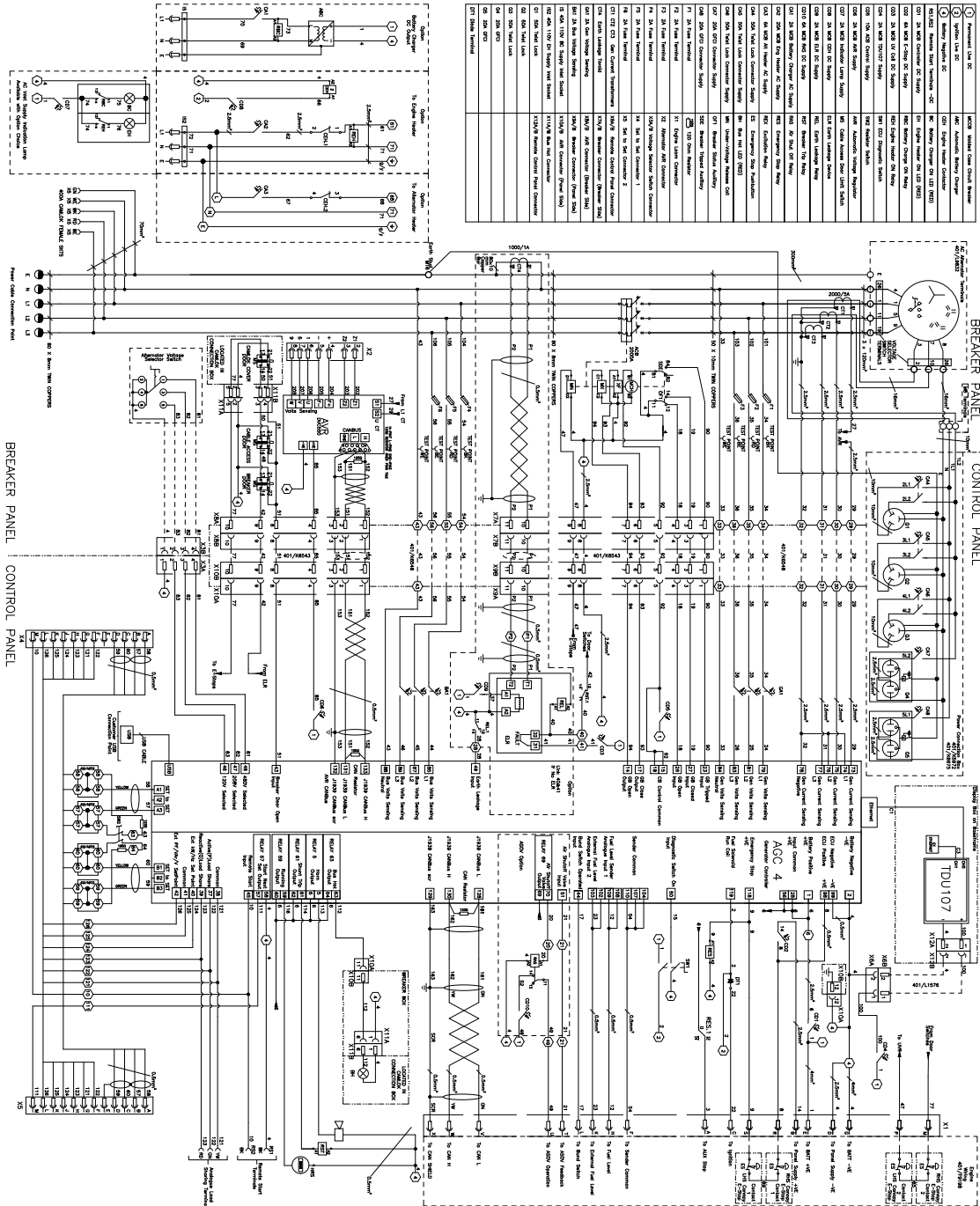

Engine

General

Table 50.

Manufacturer and Model	Volvo TWD1672GE
Fuel	Diesel
Injection	Direct
Aspiration	Turbocharged
Cylinders	6
Cooling	Water
Governor	Electronic
After treatment	SCR (Selective Catalytic Reduction)
Fuel consumption @ 75% PRP	25.8 g/h
Fuel autonomy	22h
DEF (Diesel Exhaust Fluid) consumption @75% PRP	1.83 g/h
DEF autonomy	23h

Engine Emissions

California Proposition 65

▲ WARNING Diesel engine exhaust and some of its constituents are known to the State of California to cause cancer, birth defects, and other reproductive harm.

Exhaust After Treatment (EAT)

Introduction

Your engine is equipped with an SCR (Selective Catalytic Reduction) after-treatment system. This is a fully automated system in which DEF (Diesel Exhaust Fluid) is fed into the exhaust to remove nitrogen oxides. It has a sophisticated system of self-monitoring and fault detection to ensure it is both reliable and compliant to applicable emissions legislation.

In order that the machine can be compliant across all duty cycles the performance of the SCR must be maintained. If a machine is used for a prolonged period (100s of hours) in light duties the SCR can become less efficient. Therefore the engine is equipped with a mode which runs the after-treatment system at typical operating temperatures whilst the machine is being lightly used. In this way the SCR is refreshed while the machine is running normally. This is automatic and seamless to the operator and the machine can continue to be operated normally while this is happening.

Table 51.

SCR poisoning level <95%	SCR poisoning level 95-97.5%	SCR poisoning level 97.5-98%	SCR poisoning level ≥98%	
Normal operation	Green lamp shown. Active refresh, normal operation. More load would be beneficial	Orange lamp shown. Active refresh, normal operation. More load would be beneficial	Control panel shuts engine down after 2 hrs	
			Operator restarts engine. More load would be beneficial	
			Is SCR poisoning level decreasing?	
			Yes	No
			SCR poisoning reduces, normal operation resumes	SCR poisoning level 100%
			Red lamp shown, engine begins de-rate strategy.	
			Refer to column 4	

				Control panel shuts down
				Generator is restarted but within 120 minutes the engine will severe torque and speed de-rate that will hinder the unit unusable
				Service Master unlock code to reduce SCR loading to 97.5%. Loadbank must be coupled with the generator within 120 minutes

DEF Levels

The engine or SCR will not be damaged when you run out of DEF. To protect itself the machine performance will be reduced. Refill the DEF tank to restore performance.

The engine will not shut down if you run out of DEF, however it will:

- Give the driver a warning when the remaining level falls low, which if continually ignored will progressively automatically reduce engine torque and reduce engine speed.
- Allow only enough power for 'limp home' i.e to move the machine to a safe area or onto a trailer.
- Restore power when the DEF tank is refilled.

DEF is required for type approval, operators attempting to operate the machine without DEF may be liable for civil and criminal prosecution in the European Union.

If there are no other engine or emission system faults, the information below explains when the engine power and speed de-ratings occur, according to DEF tank level.

Figure 73. DEF Level Warning Graph

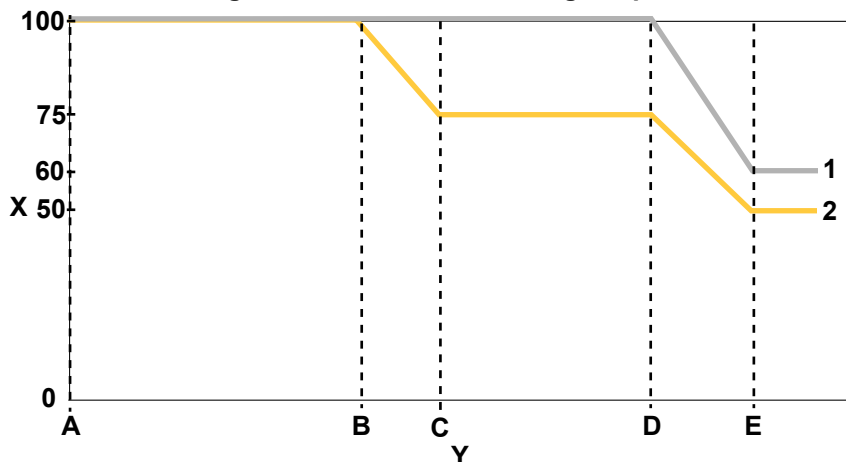

A 15% DEF level warning - Fill up this shift

B 5% DEF level - Machine starts to derate. Torque derates to 75% over 25min fill up now.

C Machine derated to 75% torque - Fill up now

D 0% DEF level - Engine torque derates to 50% and engine speed to 60% over 30min- Fill up now

E Engine derated and will remain at derated levels until filled up- Fill up now

1 Engine speed

2 Engine torque

X Percentage

Y Time

Emissions System- First Fault

The presence of emissions system related faults will result in (initially) warnings given and engine power reduction. If the warnings continue to be ignored, it will lead to the engine being only able to idle, and then only at reduced idle power.

If the engine is shut down by the operator during these steps, unless the fault is repaired, the duration of the step will resume from the point at which it was left.

If the fault is still detected again when the engine is restarted, the engine will continue at reduced power and torque.

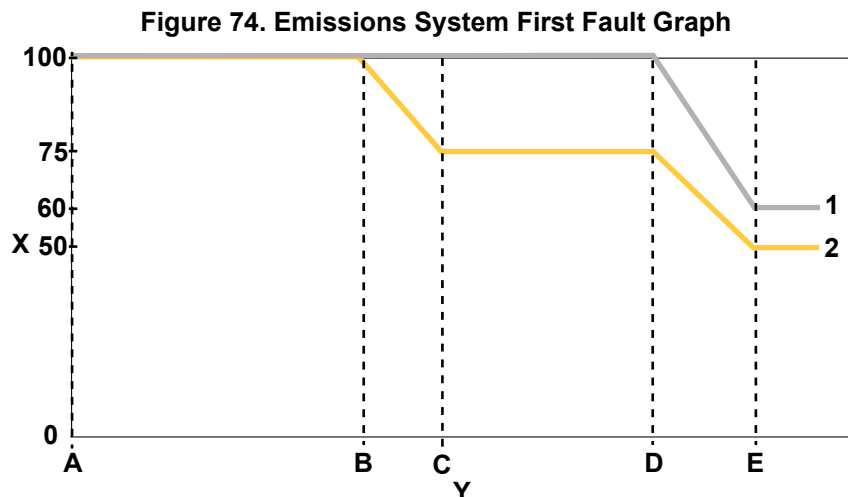

A Fault detected

B If fault is not rectified engine torque derates after 10h. Torque derates to 75% in 25min

C Engine torque derated to 75%

D Fault still not rectified. After another 10h engine speed derates to 60% and torque to 50% in 25min

E Engine torque will remain at 50% and engine speed 60% until fault is rectified

1 Engine speed

2 Engine torque

X Percentage

Y Time

Emissions Systems Faults - Additional Faults Within 40 Hours of The First Fault

If the emissions system detects a second fault within 40 engine hours of a previous fault occurring, the system will reduce power immediately to protect the engine, this is usually indicative of a more serious fault with the system. The system will return to normal operation when the fault(s) are repaired.

Table 52. Emissions system-Faults occurring in less than 40 hours

Parameter	Subsequent Fault Effects
Engine power output	Initial full power further reduces to limited power at reduced speed only over time.
Engine RPM limit	Reducing to reduced speed only over time
Driver/operator action needed	If appropriate to the application, park the machine in a safe place. Contact your JCB engines dealer immediately

DEF DO's and DON'Ts

DO's

- Before engine start up, locate and identify both separate diesel and DEF tanks, they do not share the same tank. Do not allow cross contamination between diesel and DEF.
- Act on machine warnings that DEF is running low.
- Ensure that there is sufficient DEF in the machine at all times.
- Use only high quality DEF to ISO 22241-1 from a reputable source.
- Keep all DEF, tanks, tank necks, drums and dispensing equipment clean to prevent contamination.

DON'Ts

- Don't allow contamination of your DEF by dirt or fluid as it will damage the SCR system.
- Don't mix DEF with your diesel; it is not a fuel additive.
- Don't put DEF in your diesel tank – if you do, do not start the engine, call your JCB dealer immediately.
- Don't add chemicals to your DEF to prevent freezing.
- Don't dilute DEF with water or any other fluids or the machine may stop or be permanently damaged.



Wheels and Tires

Tire Sizes and Pressures

Table 53.

ST235/85R16E	5.5bar (80psi)
--------------	----------------

Warranty Information

General

The machine must be maintained in accordance with the regular maintenance requirements detailed in this handbook. Only suitable trained personal should carry out the regular servicing.

Only Genuine JCB parts, or parts of equivalent quality should be used.

Installation Access

Your JCB Generator will need to be made available for scheduled and unscheduled maintenance work. Units should always be sited to enable reasonable unrestricted access for regular maintenance and repair work. Significant extra costs incurred for gaining access to a generator due to the installation are the responsibility of the customer and will not be covered by warranty.

Downtime Support

If you require a substitute power source during maintenance or repair then alternative power generation must be arranged. JCB do not provide replacement units under warranty, however your JCB dealer may be able to assist in sourcing a substitute generator during any periods of work.

Terms and Conditions

The following warranty terms and conditions are applicable, for further details please contact your JCB dealer:

- – 18 months from date of despatch from JCB or 12 months from first date in service (whichever is earlier).
- – Cross-hire, consequential damage and third party losses are not warrantable.
- – Extended warranty is available for up to 2 years from first date in service, contracts and conditions applicable and administered by JCB Service.

Emergency Standby Power (ESP)

Warranty is 18 months from date of despatch or 12 months from date of commissioning or whichever comes earlier. The unit should not be expected to run more than 200 hours per year.

Prime Power (PRP)

Warranty is 18 months from date of despatch or 12 months from date of commissioning or whichever comes earlier. The unit, operating on variable load, should have an average load not exceeding 75% of PRP rating

Continuous Power (COP) and Limited Time Running Power (LTP)

For machines to be used for such applications the application must first be approved by JCB and then a specific warranty period will be advised.



Notes:
