

# SERVICE MANUAL

MOBILE ELEVATING WORK PLATFORM  
**S1932E EDRV, S2632E EDRV,  
S2646E EDRV, S3246E EDRV,  
S4046E EDRV, S4550E EDRV**



EN - 9823/9150 - ISSUE 5 - 10/2025


This manual contains original instructions, verified by the manufacturer (or their authorized representative).

Copyright 2025 © JCB SERVICE  
All rights reserved. No part of this publication may be reproduced, stored in a retrieval system, or transmitted in any form or by any other means, electronic, mechanical, photocopying or otherwise, without prior permission from JCB SERVICE.

[www.jcb.com](http://www.jcb.com)

## Foreword

### The Operator's Manual

 You and others can be killed or seriously injured if you operate or maintain the machine without first studying the Operator's Manual. You must understand and follow the instructions in the Operator's Manual. If you do not understand anything, ask your employer or JCB dealer to explain it.

Do not operate the machine without an Operator's Manual, or if there is anything on the machine you do not understand.

Treat the Operator's Manual as part of the machine. Keep it clean and in good condition. Replace the Operator's Manual immediately if it is lost, damaged or becomes unreadable.

### Contents

- [01 - Machine](#)
- [06 - Body and Framework](#)
- [24 - Brake System](#)
- [25 - Steering System](#)
- [27 - Driveline](#)
- [30 - Hydraulic System](#)
- [33 - Electrical System](#)
- [72 - Fasteners and Fixings](#)
- [75 - Consumable Products](#)
- [78 - After Sales](#)



---

Notes:

---

---

---

---

---

---

---

---

---

---

---

---

---

---

---

---

---



**SERVICE MANUAL**  
Volume 1

S1932E EDRV, S2632E EDRV,  
S2646E EDRV, S3246E EDRV,  
S4046E EDRV, S4550E EDRV

EN 9823/9150



**SERVICE MANUAL**  
Volume 2

S1932E EDRV, S2632E EDRV,  
S2646E EDRV, S3246E EDRV,  
S4046E EDRV, S4550E EDRV

EN 9823/9150



**SERVICE MANUAL**  
Volume 3

S1932E EDRV, S2632E EDRV,  
S2646E EDRV, S3246E EDRV,  
S4046E EDRV, S4550E EDRV

EN 9823/9150



**SERVICE MANUAL**  
Volume 4

S1932E EDRV, S2632E EDRV,  
S2646E EDRV, S3246E EDRV,  
S4046E EDRV, S4550E EDRV

EN 9823/9150





# 01 - Machine

Contents	Page No.
Acronyms Glossary .....	01-2
01-03 Safety	
01-03-03 Safety - Yours and Others .....	01-3
01-03-06 Safety Warnings .....	01-4
01-03-09 General Safety .....	01-5
01-03-12 Maintenance Safety .....	01-6
01-03-18 Operating Safety .....	01-7
01-03-21 Worksite Safety .....	01-9
01-03-24 Risk Assessment .....	01-10
01-03-27 Maintenance Positions .....	01-11
01-06 About this Manual	
01-06-03 Model and Serial Number .....	01-14
01-06-06 Using the Manual .....	01-15
01-09 Description	
01-09-12 Main Component Locations .....	01-17
01-09-15 Service Point Locations .....	01-23
01-12 Operation	
01-12-00 General .....	01-29
01-27 Lifting the Machine	
01-27-00 General .....	01-58
01-33 Cleaning	
01-33-00 General .....	01-60
01-48 Specifications	
01-48-09 Static Dimensions .....	01-62
01-48-10 Weights .....	01-65
01-48-12 Lift Arm Dimensions and Performance .....	01-68



---

## Acronyms Glossary

AC	Alternating Current
DC	Direct Current
ECU	Electronic Control Unit
LCD	Liquid Crystal Display
LED	Light Emitting Diode
PIL	Parts Identification List
PPE	Personal Protective Equipment
RCD	Residual Current Device

## 03 - Safety

### 03 - Safety - Yours and Others

#### Introduction

All machinery can be hazardous. When a machine is correctly operated and maintained, it is a safe machine to work with. When it is carelessly operated or poorly maintained it can become a danger to you (the operator) and others.

In this manual and on the machine you will find warning messages, you must read and understand them. They inform you of potential hazards and how to avoid them. If you do not fully understand the warning messages, ask your employer or JCB dealer to explain them.

Safety is not just a matter of responding to the warnings. All the time you are working on or with the machine you must be thinking of what hazards there might be and how to avoid them.

Do not work with the machine until you are sure that you can control it.

Do not start any work until you are sure that you and those around you will be safe.

If you are not sure of anything, about the machine or the work, ask someone who knows. Do not assume anything.

Remember:

- Be careful.
- Be alert.
- Be safe.

## 06 - Safety Warnings

### Introduction

In this manual there are safety notices. Each notice starts with a signal word. The signal word meanings are given below.

The signal word 'DANGER' indicates a hazardous situation which, if not avoided, will result in death or serious injury.

The signal word 'WARNING' indicates a hazardous situation which, if not avoided, could result in death or serious injury.

The signal word 'CAUTION' indicates a hazardous situation which, if not avoided, could result in minor or moderate injury.

The signal word 'Notice' indicates a hazardous situation which, if not avoided, could result in machine damage.

The safety alert system symbol (shown) also helps to identify important safety messages in this manual. When you see this symbol your safety is involved, carefully read the message that follows.

**Figure 1. The safety alert system symbol**



## 09 - General Safety

### Introduction

#### Training

To operate the machine safely you must have received the appropriate training. The operator's manual instructs you on the machine, its controls and its safe operation; it is not a training manual. Ensure that you receive the correct training before operating the machine. Failure to do so will result in incorrect operation of the machine and you will be putting yourself and others at risk. You must abide by all local site regulations. Make sure that you and your machine comply with relevant local laws and jobsite requirements – it is your responsibility.

#### Care and Alertness

All the time you are working with or on the machine, take care and stay alert.

#### Clothing

You can be injured if you do not wear the correct clothing. Loose clothing can get caught in the machinery. Keep cuffs fastened. Do not wear a necktie or scarf. Keep long hair restrained. Remove rings, watches and personal jewellery.

#### Alcohol and Drugs

It is extremely dangerous to operate or work on machines when under the influence of drugs or alcohol. Do not consume alcoholic drinks or take drugs before or while operating any machinery. Medicines could reduce your ability to control the machine safely due to their possible side effects such as drowsiness, dizziness, loss of touch, blurred vision etc. This list is not totally exhaustive, consult your doctor if you are unsure.

#### Feeling Unwell

Do not attempt to operate the machine if you are feeling unwell. By doing so you could be a danger to yourself and those you work with. If you begin to feel unwell during operation stop using the machine immediately and seek help.

#### Mobile Phones

Switch off your mobile phone before entering an area with a potentially explosive atmosphere. Sparks in such an area could cause an explosion or fire resulting in death or serious injury.

#### Lifting Equipment

You can be injured if you use incorrect or faulty lifting equipment. You must identify the weight of the item to be lifted then choose lifting equipment that is strong enough and suitable for the job. Make sure that lifting equipment is in good condition and complies with all local regulations.

#### Raised Machine

Never position yourself or any part of your body inside the raised scissor pack which is not correctly supported. If the machine moves unexpectedly you could become trapped and suffer serious injury or be killed.

#### Lightning

Lightning can kill you. Do not use the machine if there is lightning in your area.

#### Machine Modifications

This machine is manufactured in compliance with prevailing legislative requirements. It must not be altered in any way which could affect or invalidate its compliance. For advice consult your JCB dealer.

## 12 - Maintenance Safety

### Introduction

#### Raised Machine

Never position yourself or any part of your body inside the raised scissor pack which is not correctly supported. If the machine moves unexpectedly you could become trapped and suffer serious injury or be killed.

#### Compressed Air

Compressed air is dangerous. Wear personal protective equipment. Never point a compressed air jet at yourself or others.

#### Springs

Always wear personal protective equipment when dismantling assemblies containing components under pressure from springs. This will protect against eye injury from components accidentally flying out.

#### Metal Splinters

You can be injured by flying metal splinters when driving metal pins in or out. Use a soft faced hammer or copper drift to remove and install metal pins. Always wear personal protective equipment.

#### Repairs

If your machine does not function correctly in any way, get it repaired straight away. Neglect of necessary repairs could result in an accident or affect your health. Do not try to do repairs or any other type of maintenance work you do not understand. To avoid injury and/or damage get the work done by a specialist engineer.

#### Hydraulic Pressure

Hydraulic fluid at system pressure can injure you. Before connecting or removing any hydraulic hose, residual hydraulic pressure trapped in the service hose line must be vented. Make sure the hose service line has been vented before connecting or removing hoses. Make sure the machine cannot be started while the hoses are open.

#### 'O' rings, Seals and Gaskets

Badly installed, damaged or rotted 'O' rings, seals and gaskets can cause leakages and possible accidents. Renew whenever disturbed unless otherwise instructed. Do not use Trichloroethane or paint thinners near 'O' rings and seals.

#### Soft Ground

A machine can sink into soft ground, never work under or on a machine parked on soft ground.

#### Working Under the Machine

Make the machine safe. Make sure the park brake is engaged and machine is fully isolated. Remove the machine key switch, disconnect the battery. Use blocks to prevent unintentional movement of the wheels.

#### Hydraulic Hoses

Never re-use hydraulic hose end crimps or use reusable hose end crimps.

#### Personal Protective Equipment

Use the appropriate personal protective equipment before performing maintenance on the machine, otherwise you could be injured.

#### Working at Height

Use appropriate access equipment such as ladders or a working platform if it is necessary to work at height to perform maintenance tasks on the machine. If you do not use suitable access equipment there is a risk of falling, resulting in personal injury or death.

## 18 - Operating Safety

### Introduction

#### Training

Make sure that you have had adequate training and that you are confident in your ability to operate the machine safely before you use it. Practice using the machine and its attachments until you are completely familiar with the controls and what they do. Where applicable you may be required to show competency to a national certification scheme. Ensure you comply with local legislation and jobsite rules. With a careful, well trained and experienced operator, your machine is a safe and efficient machine. With an inexperienced or careless operator, it can be dangerous. Do not put your life, or the lives of others, at risk by using the machine irresponsibly. Before you start to work, tell your colleagues what you will be doing and where you will be working. On a busy site, use a signalman.

Before doing any job not covered in this manual, find out the correct procedure. Your local JCB distributor will be glad to advise you.

#### Machine Condition

A defective machine can injure you or others. Do not operate a machine which is defective or has missing parts. Make sure the maintenance procedures in this manual are completed before using the machine.

#### Machine Limits

Operating the machine beyond its design limits can damage the machine, it can also be dangerous. Do not operate the machine outside its limits. Do not try to upgrade the machine performance with unapproved modifications or additional equipment.

#### Communications

Bad communications can cause accidents. Keep people around you informed of what you will be doing. If you will be working with other people, make sure any hand signals that may be used are understood by everybody. Worksites can be noisy, do not rely on spoken commands.

You must stop the machine operation, isolate the controls and turn off the machine when persons are required to interact with it.

#### Parking

An incorrectly parked machine can move without an operator. Follow the instructions in the Operator's Manual to park the machine correctly.

#### Banks and Trenches

Banked material and trenches can collapse. Do not work or drive too close to banks and trenches where there is danger of collapse.

#### Safety Barriers

Unguarded machines in public places can be dangerous. In public places, or where your visibility is reduced, place barriers around the work area to keep people away.

#### Sparks

Explosions and fire can be caused by sparks from the electrical system. Do not use the machine in closed areas where there is flammable material, vapour or dust.

#### Regulations

Obey all laws, worksite and local regulations which affect you and your machine.

#### Electrical Power Cables

You could be electrocuted or badly burned if you get the machine or its attachments too close to electrical power cables.

You are strongly advised to make sure that the safety arrangements on site comply with the local laws and regulations concerning work near electric power lines.

Before you start using the machine, check with your electricity supplier if there are any buried power cables on the site.

There is a minimum clearance required for working beneath overhead power cables. You must obtain details from your local electricity supplier.

#### Machine Safety

Stop work at once if a fault develops. Abnormal sounds and smells can be signs of trouble. Examine and repair before resuming work.

#### Travelling at High Speeds

Travelling at high speeds can cause accidents. Always travel at a safe speed to suit working conditions.

#### Travelling at Height

If it is not part of the work task, lower the platform before travelling. Only travel at height if it is necessary and the travel area has been inspected.

#### Confined Areas

Pay extra attention to proximity hazards when operating in confined areas. Proximity hazards include buildings, traffic and bystanders.

#### Safe Working Loads

Overloading the machine can damage it and make it unstable. Study the specifications in the Operator's Manual before using the machine.



### **Lightning**

If there is lightning, stay away from the machine and do not use the machine. If you are on the machine, exit the machine and get to safety. Do not attempt to mount or enter the machine.

If the machine is struck by lightning do not use the machine until it has been checked for damage and malfunction by trained personnel.

### **Tools and Objects**

Do not cover the platform sides or carry objects with a large surface area when operating outdoors.

### **Machine Safety**

If during operation an error code(s) is displayed you must lower the machine to the fully stowed position. If the error code(s) is still displayed after performing a key cycle stop using the machine immediately and contact your JCB dealer for assistance.

## 21 - Worksite Safety

### Introduction

"Workplace Inspection" will help operators to determine whether the workplace is suitable for operation. Operators must inspect the workplace before they move machines there. It is the operator's responsibility to understand and keep in mind the hazards in the workplace, He/she must pay attention and avoid these problems when moving, installing and operating the machine. Check for hazards such as but not limited to:

- Drop-offs, or potholes including those concealed by water mud, etc.
- Slopes.
- Bumps and floor obstructions.
- Debris.
- Over head obstructions and electrical conductors.
- Hazardous locations and atmospheres.
- Inadequate surface and support to withstand all load forces imposed by the platform in all operating configurations.
- Wind and weather conditions.
- Presence of unauthorized persons.
- Other possible unsafe conditions.
- Underground utilities and pipes.
- Overhanging objects, tree branches.

## 24 - Risk Assessment

### Introduction

It is the responsibility of the competent people that plan the work and operate the machine to make a judgement about the safe use of the machine, they must take into account the specific application and conditions of use at the time.

It is essential that a risk assessment of the work to be done is completed and that the operator obeys any safety precautions that the assessment identifies.

If you are unsure of the suitability of the machine for a specific task, contact your JCB dealer who will advise you.

The following considerations are intended as suggestions of some of the factors to be taken into account when a risk assessment is made. Other factors may need to be considered.

A good risk assessment depends on the training and experience of the operator. Do not put your life or the lives of others at risk.

### Personnel

- Are all persons who will take part in the operation sufficiently trained, experienced and competent? Are they fit and sufficiently rested? A sick or tired operator is a dangerous operator.
- Is supervision needed? Is the supervisor sufficiently trained and experienced?
- As well as the machine operator, are any assistants or lookouts needed?

### The Machine

- Is it in good working order?
- Have any reported defects been corrected?
- Have the daily checks been carried out?
- Are the tyres in good condition?
- Is the battery sufficiently charged to complete the job?

### Working Area

- Is it level?
- Is the ground solid? Will it support the weight of the machine when loaded?
- How rough is the ground? Are there any sharp projections which could cause damage, particularly to the tyres?
- Are there any obstacles or hazards in the area, for example, debris, excavations, manhole covers, power lines?
- Is the space sufficient for safe manoeuvring?
- Are any other machines or persons likely to be in or to enter the area while operations are in progress?

### The Route to be Travelled

- How solid is the ground, will it provide sufficient traction and braking? Soft ground will affect the stability of the machine and this must be taken into account.
- How steep are any slopes, up/down/across? A cross slope is particularly hazardous, is it possible to detour to avoid them?

### Weather

- How windy is it? High wind will adversely affect the stability of a loaded machine.
- Is it raining or is rain likely? The ground that was solid and smooth when dry will become uneven and slippery when wet, and it will not give the same conditions for traction, steering or braking.

### Emergency Plan

Make sure that emergency rescue plan is in place and understood by those involved, it is important to make sure that those involved in the rescue plan are aware of the location of the lowering controls and how to operating the machine from platform controller at height.

### Emergency Stop Check

The emergency stop or E-Stop is a round and red colour switch located on the base control panel as well as on the platform control unit. The button performs an instant shutdown operation of all functions in case of an emergency.

The usage of the emergency switch and the reactions triggered are as follows:

#### During Lift /lower

- Instant shutdown of the machine and stoppage of the lift/lower application.

#### During Drive

- Shutting down the machine and applying full brake force to bring the machine to a stop as quickly as possible.

A properly functioning E-Stop switch is necessary for the safe operation of the equipment. An improperly functioning switch may fail to shutoff the power or stop all machine functions, resulting in a hazardous situation.

The emergency stop button is to be used in case of an emergency only. It is not to be used as a regular switch for day-to-day operations.

## 27 - Maintenance Positions

### Introduction

Make the machine safe before you start a maintenance procedure.

1. Park the machine on level, solid (slabbed/paved) ground.
2. Turn off the machine and remove the key.  
[Refer to: PIL 33-24-04.](#)
3. Disconnect the battery to prevent accidental operation.  
[Refer to: PIL 33-05.](#)
4. Put wheel chocks on the front or rear side of all wheels.

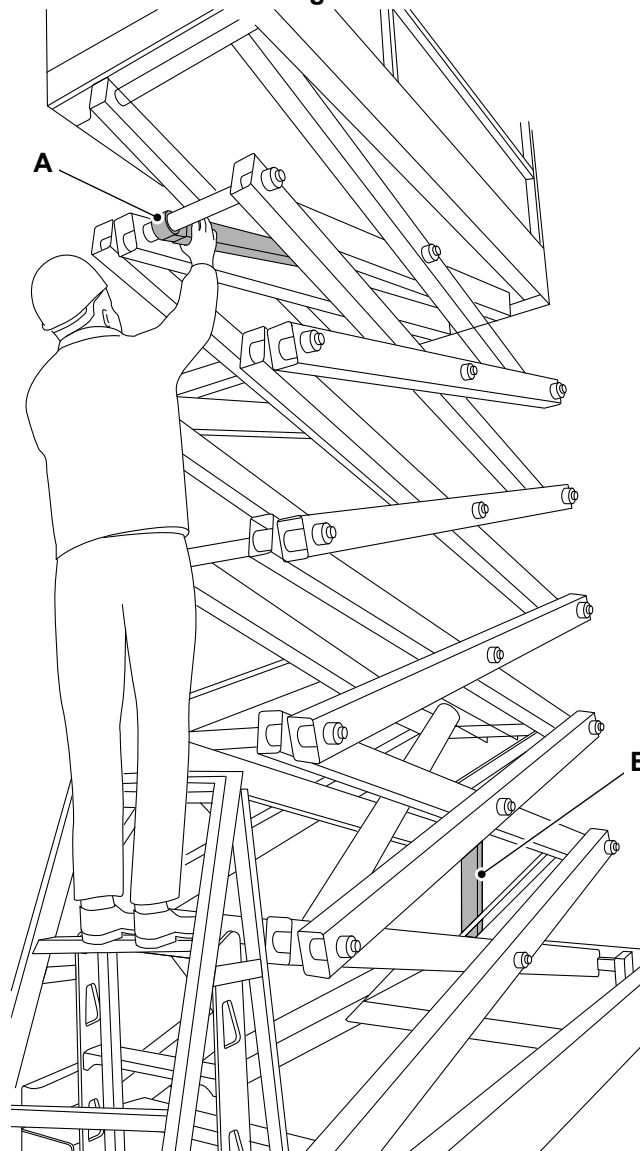
### Maintenance Position- Platform Raised

**▲ WARNING** If a second person is involved with the operation ensure that the machine controls are not operated whilst they are in the working envelope of the machine and attachment, otherwise the other person could be killed or injured if a control is moved accidentally.

Make sure that the safety strut is installed before performing any maintenance task on a raised platform.

When installing the upper safety strut always maintain three points of contact with the ladder and scissor end bars. Use the scissor end bars as handrails.

**Figure 2.**



**A** Upper safety strut

**B** Lower safety strut

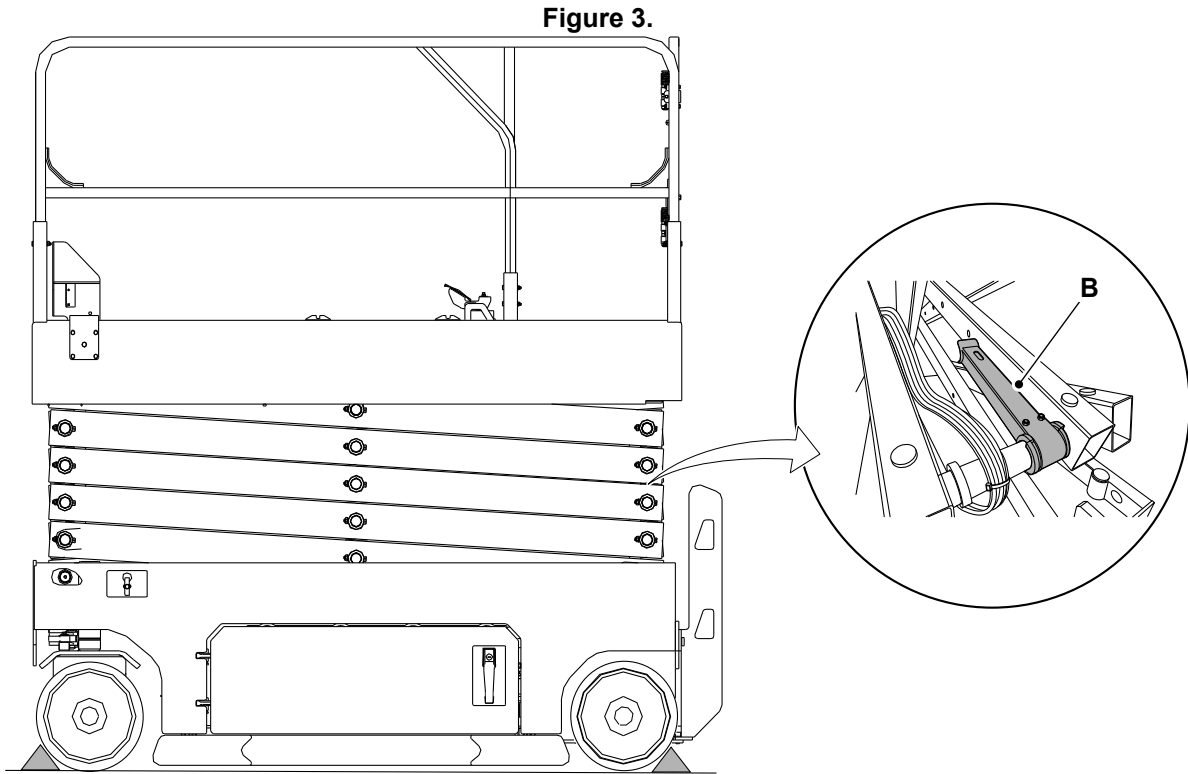
The minimum clearance height required to install the safety struts is shown. Refer to [Table 1](#).

**Table 1.**

Machine	Length
S1932 EDRV	3.61m
S2632 EDRV	3.75m
S2646 EDRV	3.75m
S3246 EDRV	4.2m
S4046 EDRV	4.6m
S4550 EDRV	4.6m

## Maintenance Position- Platform Lowered

Make sure that the safety strut is in its stowed position before lowering the platform.



**B** Safety strut stowage position



## 06 - About this Manual

### 03 - Model and Serial Number

#### Introduction

This manual provides information for the following model(s) in the JCB machine range:

Table 2.

Model	VIN Prefix. <a href="#">Refer to: PIL 06-63-03.</a>
S1932 EDRV	RAJA0151, RAJA0B51
S2632 EDRV	RAJA0452, RAJA0E52
S2646 EDRV	RAJA0552, RAJA0F52
S3246 EDRV	RAJA0653, RAJA0G53
S4046 EDRV	RAJA0753, RAJA0H53
S4550 EDRV	RAJA0854, RAJA0J54

## 06 - Using the Manual

### Introduction

Information in this manual conforms to a standard JCB service manual format. The format uses section headings taken from a PIL (Parts Identification

List). These headings are assigned numerical identification references.

**Table 3.**

Example	Section	Main Assembly / Heading	Component / Sub-heading
PIL reference	33	03	03
Heading	Electrical System	Battery	Isolator Switch

Information within each PIL reference is included under a set of standard headings such as Introduction, Health and Safety, Technical Data and Operation for example. Where additional relevant

information is contained within another PIL reference a cross reference is provided.

The main systems information is contained in the manual as follows.

**Table 4.**

System	PIL Reference	Heading
Hydraulic System	PIL 30-00-50	Schematic Circuit
Electrical System	PIL 33-03-03	Battery - Isolator Switch
	PIL 33-09-00	Power Distribution (including fuses and relays)
	PIL 33-00-50	Schematic Circuit
Electronic Diagnostic	PIL 33-57-00	Electronic Diagnostic (including Servicemaster)

### Machine Variants

Where information is different depending on machine variant, the applicable information sets are included within the same PIL reference. Headings are included to identify which information is for which variant. Make sure you use the correct information.

### Routine Maintenance

A dedicated section for routine maintenance procedures is not included. Instead, procedures are included in the relevant PIL headings. For example, procedures for the hydraulic oil filter are given in Hydraulic System, Filter (PIL 30-04).

Routine maintenance must be carried out in accordance with the applicable maintenance schedule.

Refer to: [PIL 78-24](#).

### Diagnostics

Information in this manual can help you diagnose machine faults.

Before attempting to diagnose possible faults check the following.

- Make sure that the operator understands the machine controls, functions and use. Refer to the applicable Operator Manual.
- Check that the maintenance record complies with the applicable schedule for the operating environment.
- Check that the fluids in use comply with the standards specified.
- Make sure that the machine electronic set-up is applicable. Use the applicable Servicemaster vehicle set-up tool.
- Use the applicable Servicemaster diagnostics tools.

### Remove and Install

Before removal of components or assemblies, clean the applicable parts of the machine. After removal cap open ports and hoses to prevent contamination. Refer to: [PIL 01-33-00](#).

Use new sealing elements such as gaskets and O-rings.

Do not install defective components or assemblies. if necessary replace them with new ones.

## Dismantle and Assemble

Before dismantling an assembly clean it.

After dismantling, clean the individual components and check them for wear and defects. If necessary replace them with new ones.

During assembly use new sealing elements such as gaskets and O-rings.

## Torque Tightening

When you replace components, always tighten the applicable fixings to the correct torque value. Use the torque tightening values contained in the individual procedures (Remove and Install, Disassemble and Assemble etc.). If no torque values are specified, use the standard torque tightening values. For the torque setting to be effective, do the following before you install the fixings.

[Refer to: PIL 72-00-00.](#)

- Make sure that all the applicable component assemblies are correct.
- Make sure that the applicable fixings are to the correct specification. If necessary discard the original fixings and replace them with new ones. The relevant procedures indicate when this is necessary.
- Make sure that the applicable fixings and threaded holes are free from contamination. This includes dirt, debris, old sealants and compounds, fluids and lubricants.

## Consumable Products

Some procedures require the use of consumable products such as lubricants, sealants, adhesives and locking fluids. Use the correct products. Where products are available from JCB the applicable part numbers are given in the procedures. A complete list of consumable products available from JCB is given in this manual.

[Refer to: PIL 75-00.](#)

## After Sales

Some procedures require the use of equipment such as special tools and PPE (Personal Protective Equipment). Where special tools are available from JCB the applicable part numbers are given in the procedures. Full details about the applicable special tools are given in this manual. Refer to (PIL 78-00).

Use the correct PPE to comply with local and employer regulations.



## 09 - Description

### 12 - Main Component Locations

#### Introduction

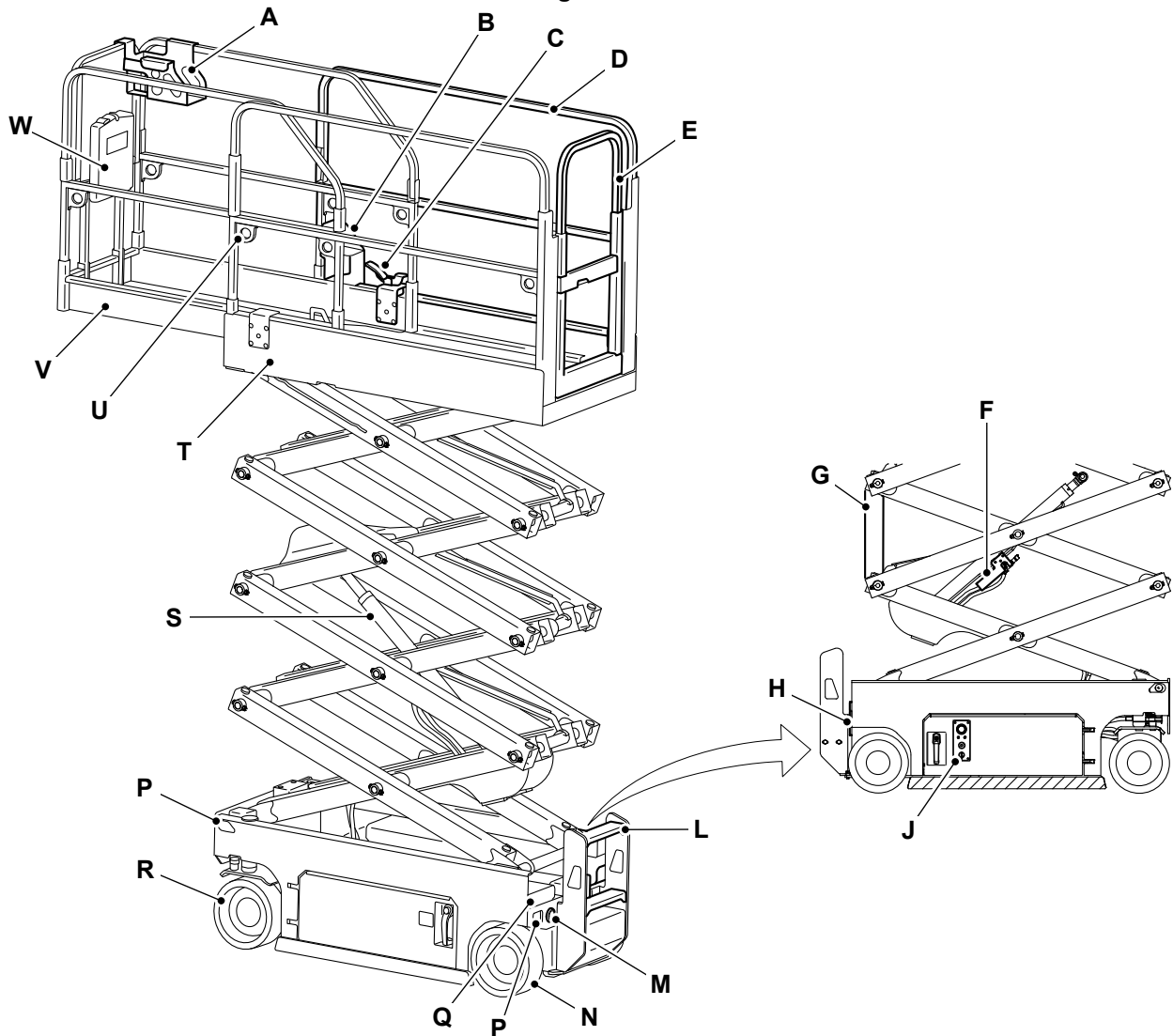
For: S1932E EDRV [RAJ], S2632E EDRV  
[RAJ], S2646E EDRV [RAJ] ..... Page 01-17

For: S3246E EDRV [RAJ], S4046E EDRV  
[RAJ], S4550E EDRV [RAJ] ..... Page 01-20

(For: S1932E EDRV [RAJ], S2632E EDRV  
[RAJ], S2646E EDRV [RAJ])

The illustration shows the typical machine. Number  
of scissor packs on your machine may be different.

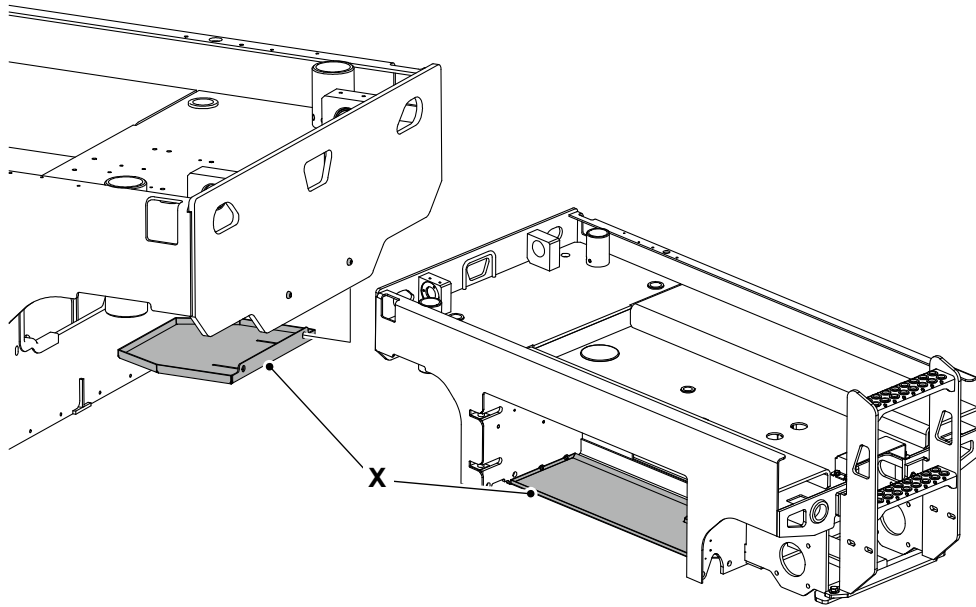
**Figure 4.**



- |   |   |
|---|---|
| <b>A</b> Platform controller                              | <b>B</b> AC (Alternating Current) power socket (option) |
| <b>C</b> Extension platform pedal                         | <b>D</b> Guardrail                                      |
| <b>E</b> Platform door                                    | <b>F</b> Lift control valve                             |
| <b>G</b> Safety strut                                     | <b>H</b> Power to platform plug                         |
| <b>J</b> Ground controller, key switch and emergency stop | <b>L</b> Ladder   |
| <b>M</b> Charging plug                                    | <b>N</b> Rear wheel                                     |
| <b>P</b> Lifting/tie-down point                           | <b>Q</b> Forklift pocket                                |
| <b>R</b> Front wheel (drive and brake)                    | <b>S</b> Lift ram                                       |
| <b>T</b> Main platform                                    | <b>U</b> Safety harness fastening point                 |
| <b>V</b> Platform extension                               | <b>W</b> Operator manual holder                         |

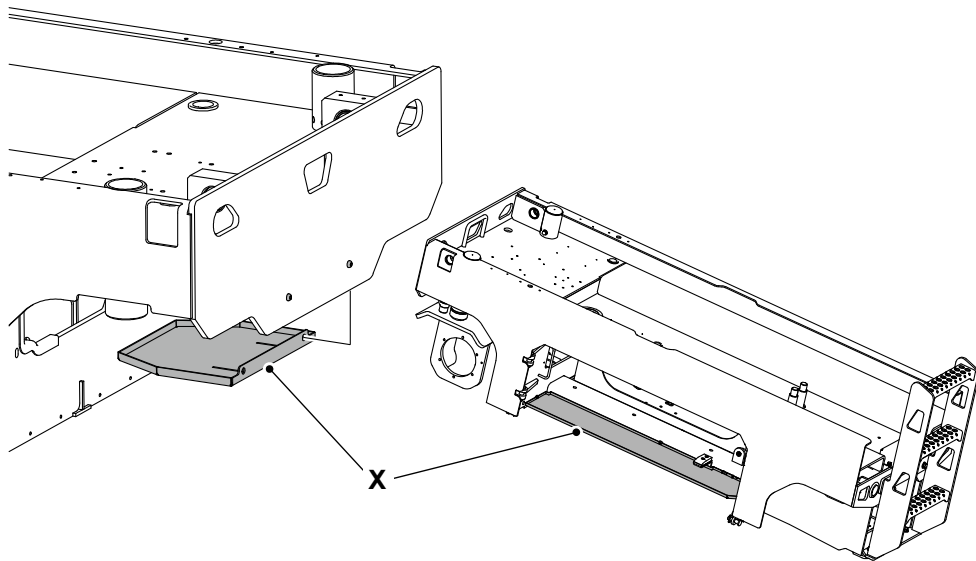
The illustration shows the typical spill kit (if fitted). Number of spill trays and its design on your machine may vary.

**Figure 5. S1932E EDRV**



**X** Spill kit

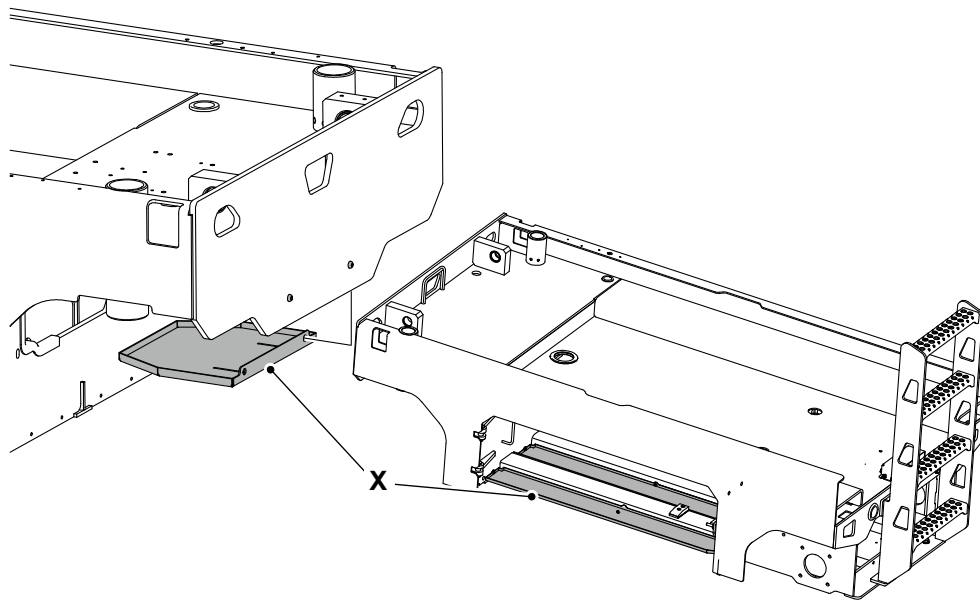
**Figure 6. S2632E EDRV**



**X** Spill kit

JCB © CONNOR STANMORE - 13/03/2026 07:57.

**Figure 7. S2646E EDRV**

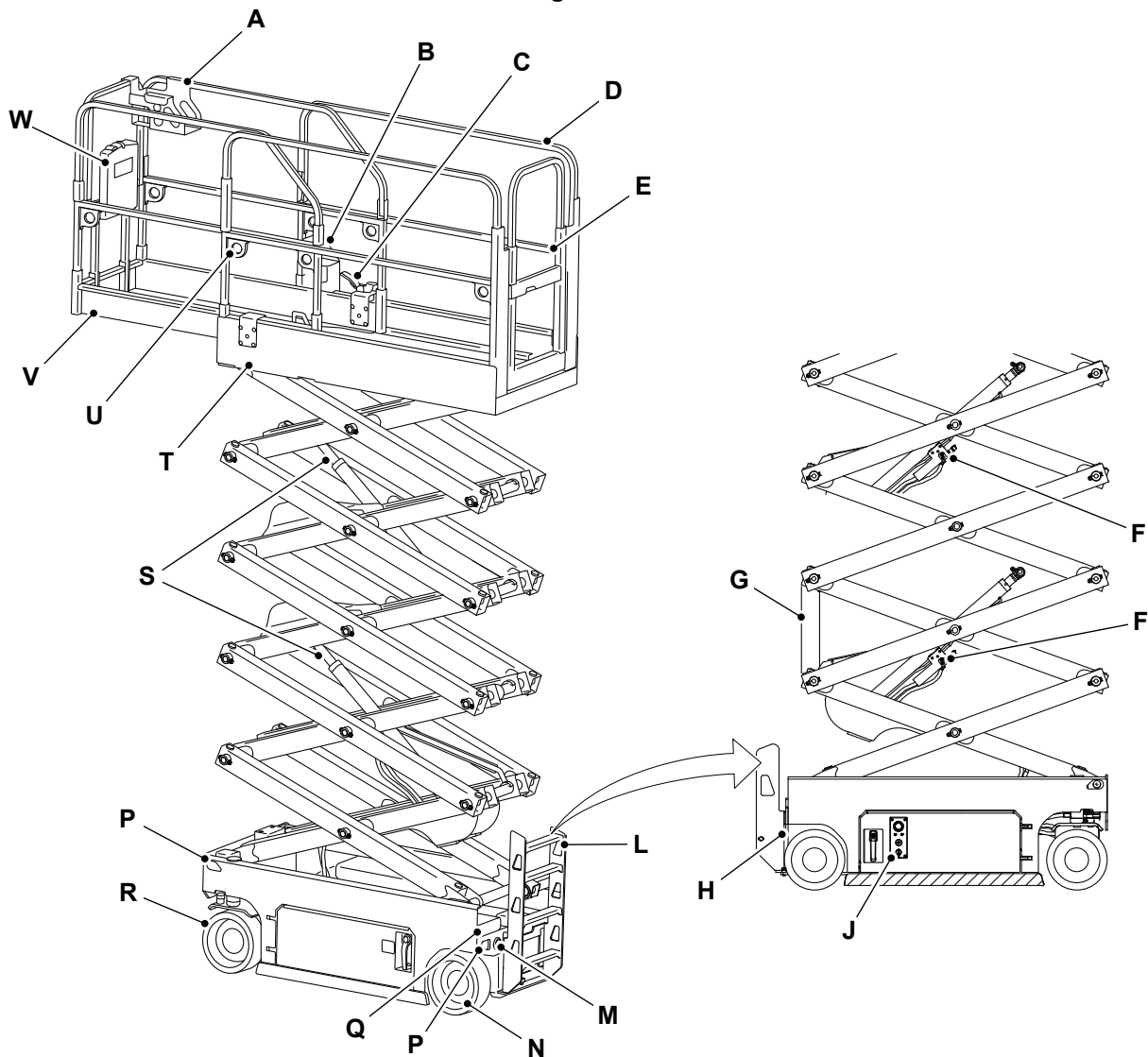


**X** Spill kit

(For: S3246E EDRV [RAJ], S4046E EDRV [RAJ], S4550E EDRV [RAJ])

The illustration shows the typical machine. Number of scissor packs on your machine may be different.

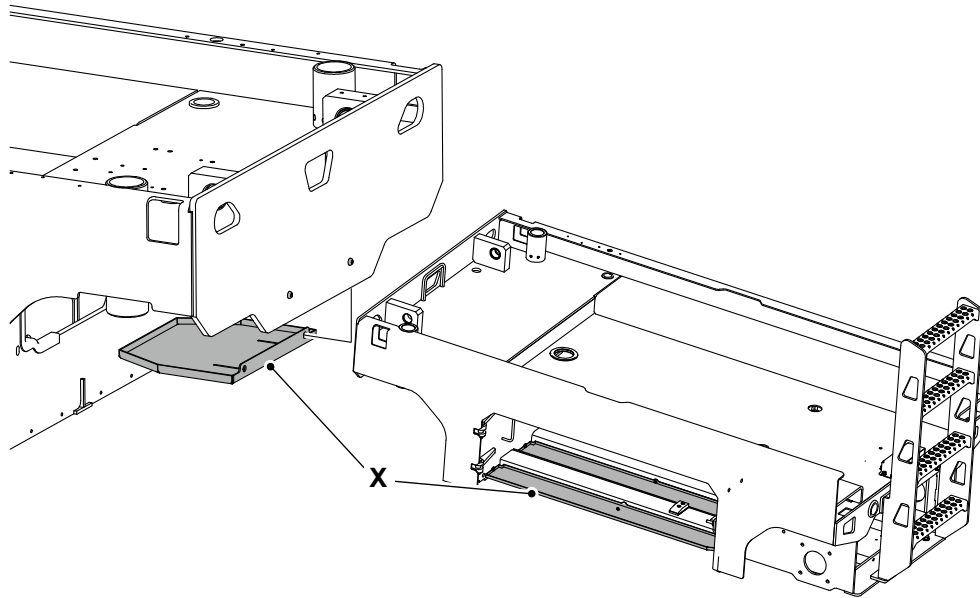
**Figure 8.**



- |   |   |
|---|---|
| <b>A</b> Platform controller                              | <b>B</b> AC power socket (option)       |
| <b>C</b> Extension platform pedal                         | <b>D</b> Guardrail                      |
| <b>E</b> Platform door                                    | <b>F</b> Lift control valve             |
| <b>G</b> Safety strut                                     | <b>H</b> Power to platform plug         |
| <b>J</b> Ground controller, key switch and emergency stop | <b>L</b> Ladder                         |
| <b>M</b> Charging plug                                    | <b>N</b> Rear wheel                     |
| <b>P</b> Lifting/tie-down point                           | <b>Q</b> Forklift pocket                |
| <b>R</b> Front wheel (drive and brake)                    | <b>S</b> Lift ram                       |
| <b>T</b> Main platform                                    | <b>U</b> Safety harness fastening point |
| <b>V</b> Platform extension                               | <b>W</b> Operator manual holder         |

The illustration shows the typical spill kit (if fitted). Number of spill trays and its design on your machine may vary.

**Figure 9. S3246E EDRV, S4046E EDRV and S4550E EDRV**



**X** Spill kit

JCB © CONNOR STANMORE - 13/03/2026 07:57.

## 15 - Service Point Locations

### Introduction

For: S1932E EDRV [RAJ] ..... Page 01-23

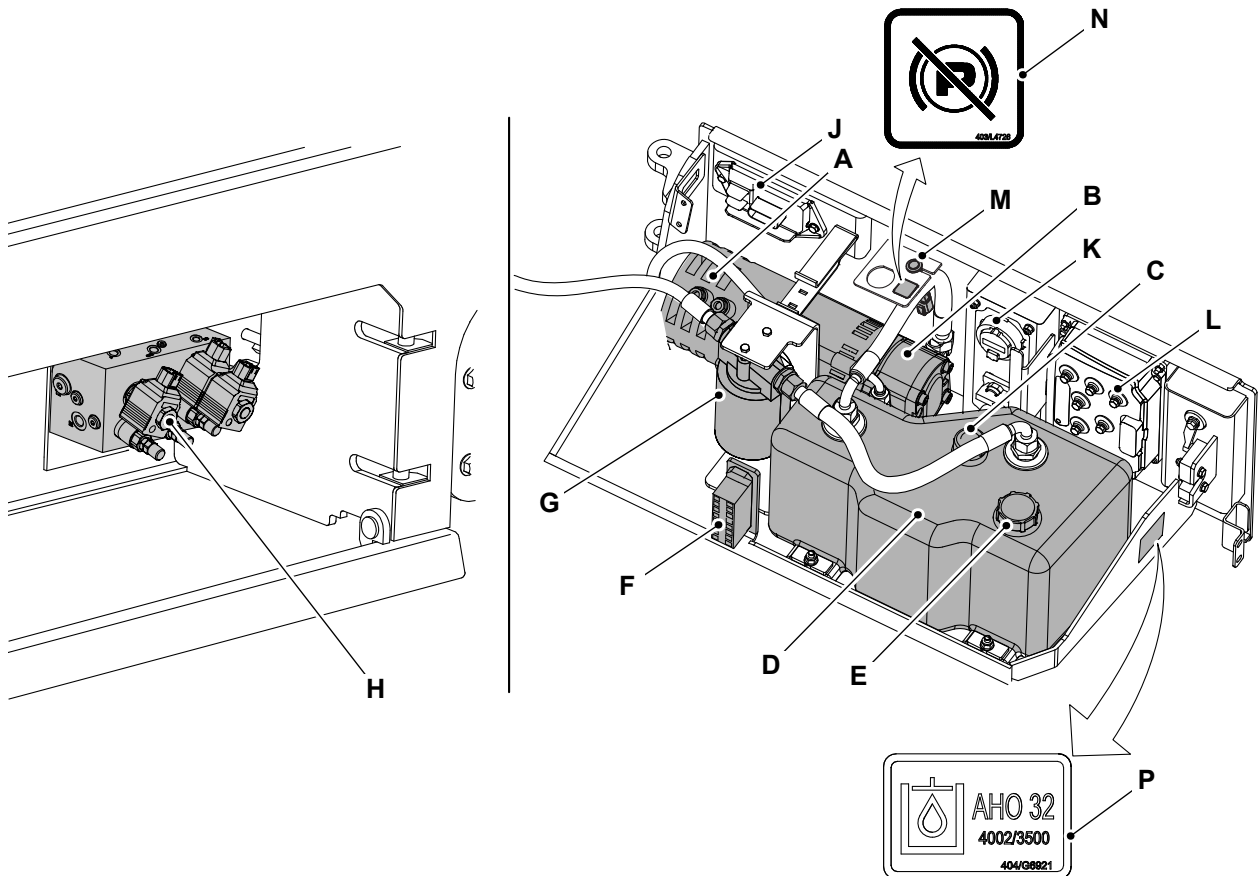
For: S2632E EDRV [RAJ], S2646E EDRV [RAJ], S3246E EDRV [RAJ], S4046E EDRV [RAJ] ..... Page 01-25

For: S4550E EDRV [RAJ] ..... Page 01-27

(For: S1932E EDRV [RAJ])

### Hydraulic Compartment

Figure 10.

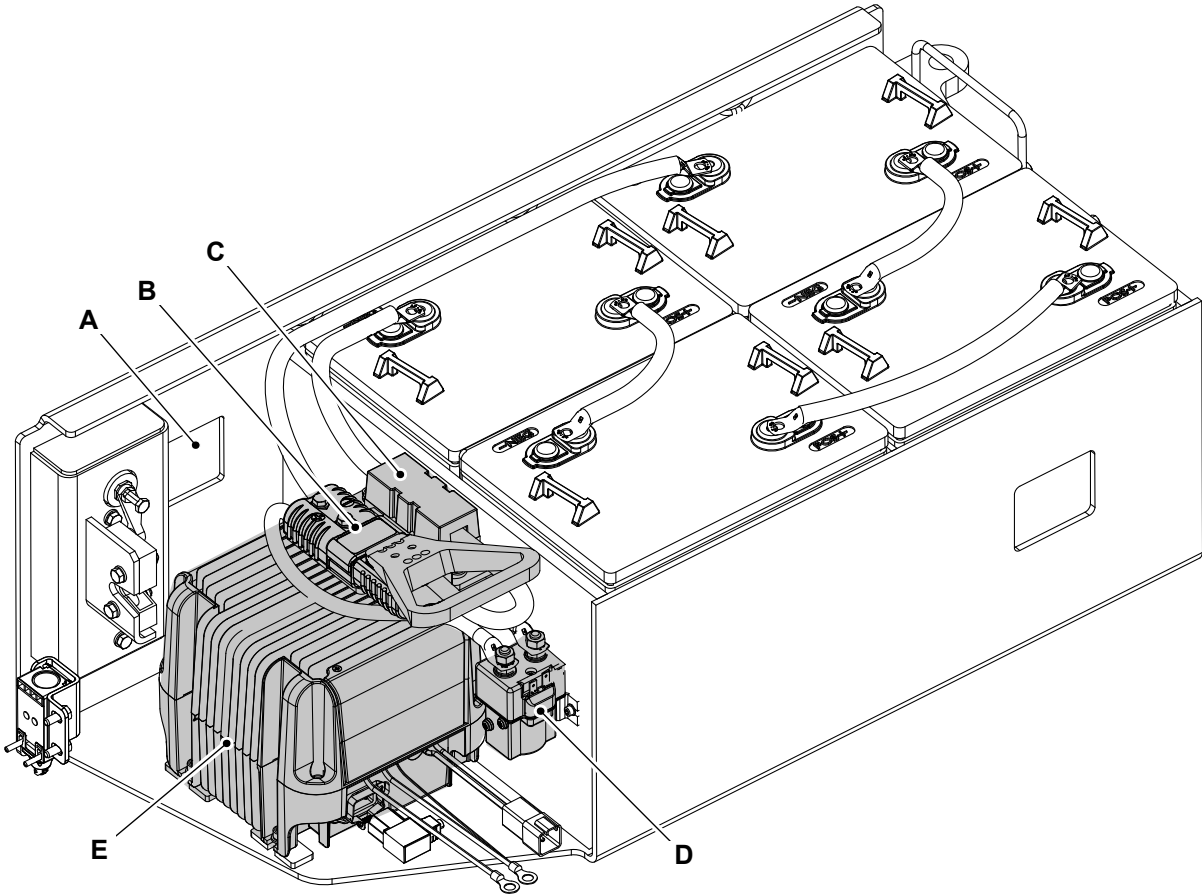


- A Motor
- C Hydraulic breather
- E Hydraulic oil filler cap
- G Hydraulic oil filter
- J ECU (Electronic Control Unit)
- L Motor controller/inverter
- N Park brake release decal (if fitted)

- B Gear pump
- D Hydraulic tank
- F Secondary fuses
- H Valve block
- K Ground control panel
- M Brake release switch (if fitted)
- P Arctic hydraulic oil 32 decal

**Battery Compartment**

**Figure 11.**



- A** Battery charger status sight hole
- C** Primary fuse (200A rating)
- E** Battery charger

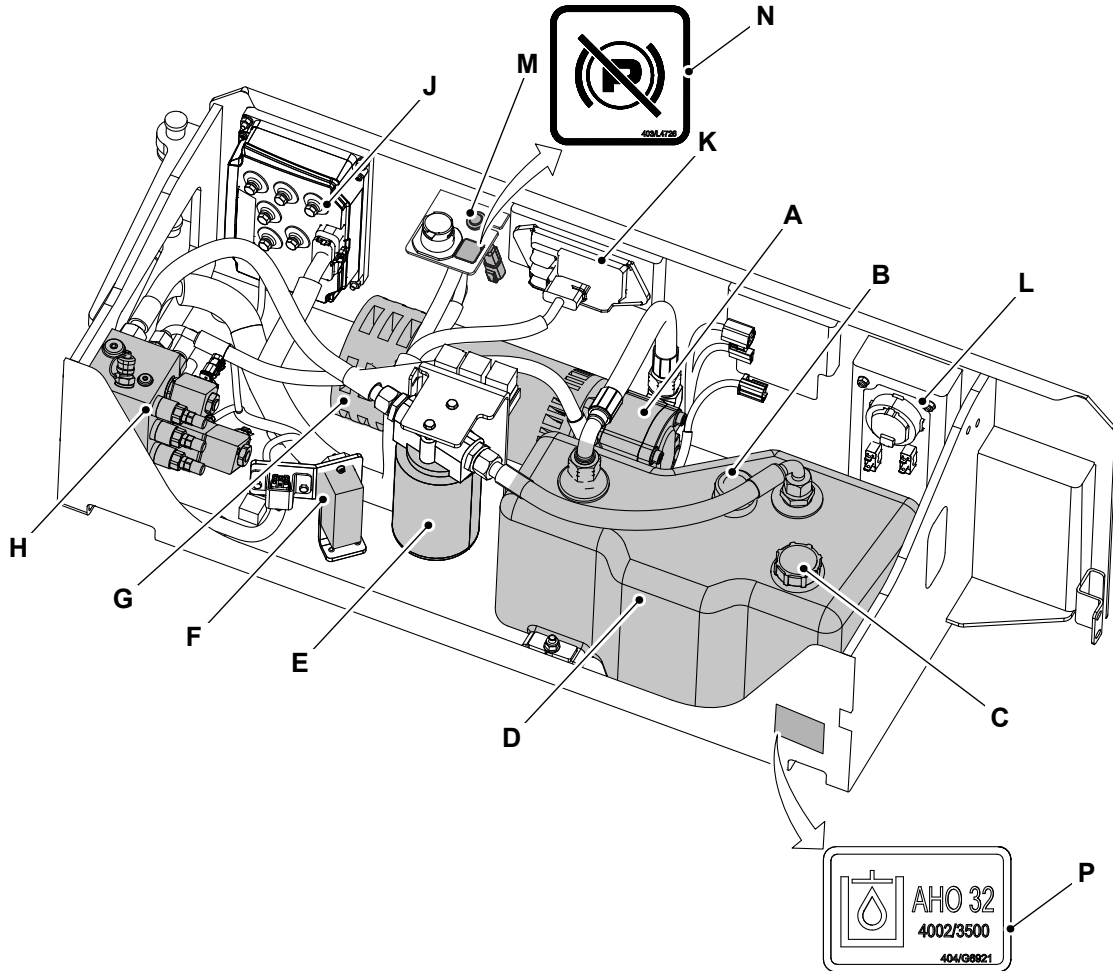
- B** Battery isolator (pull type)
- D** DC (Direct Current) contactor

JCB © CONNOR STANMORE - 13/03/2026 07:57.

(For: S2632E EDRV [RAJ], S2646E EDRV [RAJ], S3246E EDRV [RAJ], S4046E EDRV [RAJ])

**Hydraulic Compartment**

Figure 12.



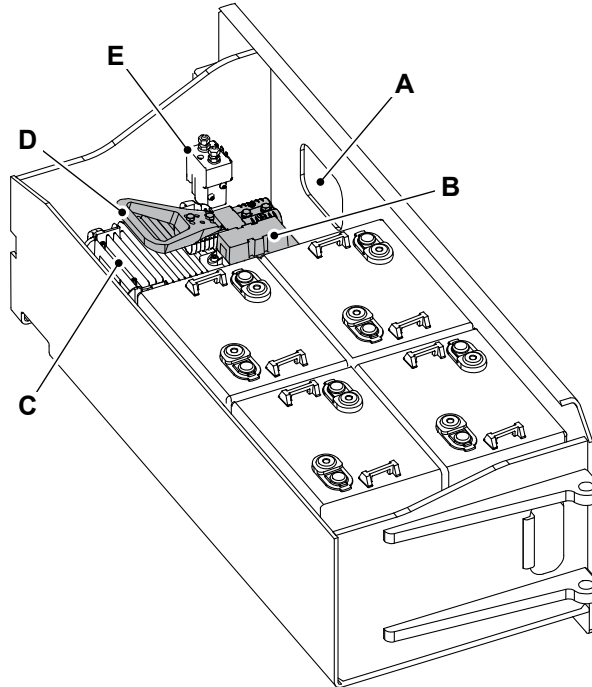
- A Gear pump
- C Hydraulic oil filler cap
- E Hydraulic oil filter
- G Motor
- J Motor controller/inverter
- L Ground control panel
- N Park brake release decal (if fitted)

- B Hydraulic breather
- D Hydraulic tank
- F Secondary fuses
- H Valve block
- K ECU
- M Brake release switch (if fitted)
- P Arctic hydraulic oil 32 decal

JCB © CONNOR STANMORE - 13/03/2026 07:57.

## Battery Compartment

Figure 13.



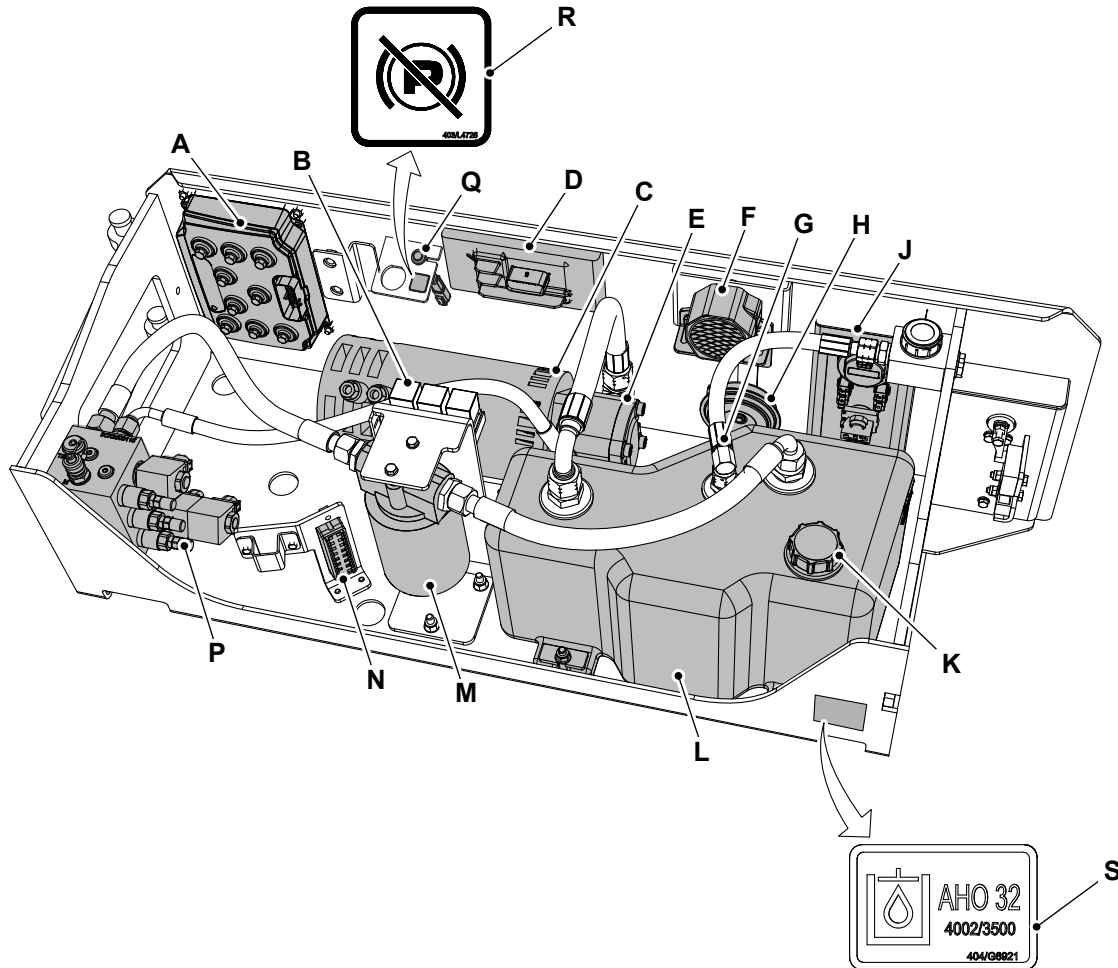
**A** Battery charger status sight hole  
**C** Battery charger  
**E** DC contactor

**B** Primary fuse (200A rating)  
**D** Battery isolator (pull type)

(For: S4550E EDRV [RAJ])

**Hydraulic Compartment**

Figure 14.

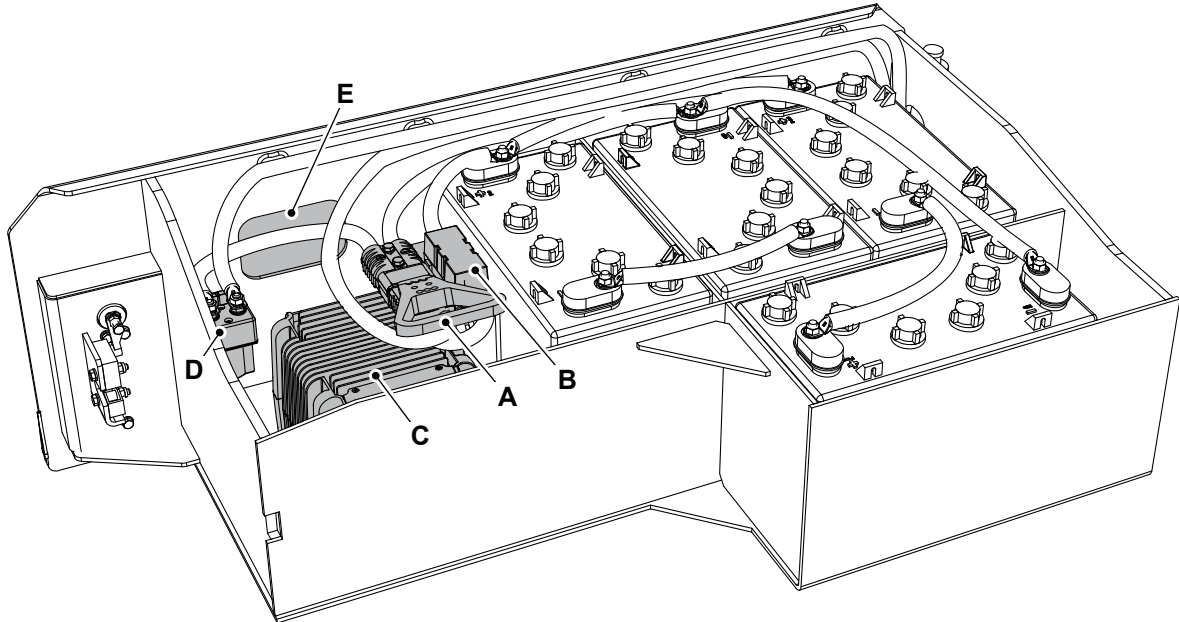


- A Motor controller
- C Motor
- E Gear pump
- G Hydraulic breather
- J Display switch
- L Hydraulic tank
- N Fuse
- Q Brake release switch (if fitted)
- S Arctic hydraulic oil 32 decal

- B Relay
- D ECU
- F White noise reverse alarm
- H Horn
- K Hydraulic oil filler cap
- M Hydraulic oil filter
- P Valve block
- R Park brake release decal (if fitted)

## Battery Compartment

Figure 15.



- A Battery isolator (pull type)
- C Battery charger
- E Battery charger status sight hole

- B Primary fuse (200A rating)
- D DC contactor



## 12 - Operation

### 00 - General

Health and Safety .....	01-29
Operation .....	01-34
Check (Operation) .....	01-37
Calibrate .....	01-40

### Health and Safety

#### Trip and Fall Hazards

- Prior to operation, make sure that platform door and all guardrails are fastened and secured.
- It is recommended that all persons in the platform wear full body harnesses with a short lanyard attached to a lanyard anchor point while operating this machine. For further information refer to JCB dealer.
- No more than one person should be attached to each lanyard anchor point.
- Keep both feet firmly on the platform floor at all times. Never position ladders, boxes, steps, planks or other similar items on unit to provide additional reach for any purpose.
- Never use the scissor arm assembly to gain access to or leave the platform.
- Keep your footwear and the platform floor clean of oil, mud and slippery substances.

#### Electrocution Hazards

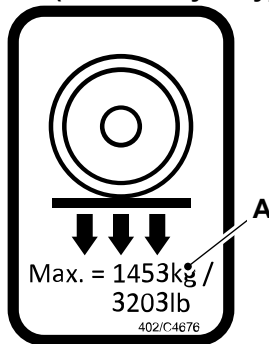
- This machine is not insulated and does not provide protection from contact or proximity to electrical current.
- Maintain distance from electrical lines, apparatus, or any energized (exposed or insulated) parts according to the minimum approach distance. [Refer to Table 5.](#)
- Allow for machine movement and electrical line swaying.
- Maintain a clearance of at least 3m between any part of the machine and its occupants, their tools, and their equipment from any electrical line or apparatus carrying up to 50,000V. One foot additional clearance is required for every additional 30,000V or less.
- The minimum approach distance may be reduced if insulating barriers are installed to prevent contact, and the barriers are rated for the voltage of the line being guarded. These barriers shall not be part of (or attached to) the machine. The minimum approach distance shall be reduced to a distance within the designed working dimensions of the insulating barrier. This determination shall be made by a qualified person in accordance with the employer, local, or governmental requirements for work practices near energized equipment.

**Table 5. Minimum Approach Distance**

Voltage Range	Minimum Approach Distance
0–50,000V	3m
50,000–200,000V	5m
200,000–350,000V	6m
350,000–500,000V	8m
500,000–750,000V	11m
750,000–1,000,000V	14m

### Tipping Hazards

- Make sure that the ground conditions are adequate to support the maximum tyre load indicated on the tyre load decals located on the chassis adjacent to each wheel. Do not travel on unsupported surfaces.

**Figure 16. Example De-  
cal (values may vary)**

**A Maximum tyre load**

- The user must be familiar with the driving surface before driving. Do not exceed the allowable sideslope and grade while driving.
- Do not raise the platform or drive with platform raised while on or near a sloping, uneven, or soft surface. Make sure that the machine is positioned on level, solid (slabbed or paved) ground before elevating the platform or driving with the platform in the elevated position.
- Before driving on floors, bridges, trucks, and other surfaces, check the allowable capacity of the surfaces.
- Never exceed the maximum work load as specified on the platform. Keep all loads within the confines of the platform. Evenly distribute the load across the platform, or the machine could become unstable.
- Do not operate the machine when wind conditions exceed the limit.
- Never attempt to use the machine as a crane. Do not tie-off machine to any adjacent structure. Never attach wire, cable, or any similar item to the platform.
- If the platform or scissor pack becomes stuck or snagged on an adjacent or overhead structure, do not try to free the machine until all personnel are removed from the platform.

- Do not push or pull from the platform against any adjacent or overhead structures.
- Do not cover platform sides or carry large surface area items in the platform when operating outdoors. The addition of such items increases the exposed wind area of the machine.
- Do not increase platform size with unauthorised deck extensions or attachments.
- Do not raise the platform with the access apertures open. Keep the access apertures closed whilst the platform is raised.
- Do not raise the platform with access apertures open and an operator is in the platform. Keep the access apertures closed whilst the platform is raised and an operator is in the platform.
- If the scissor arm or platform is caught so that one or more wheels are off the ground, all the persons and tools must be removed before attempting to free the machine. Use a crane, forklift truck, or other appropriate equipment to stabilise the machine and remove the personnel.

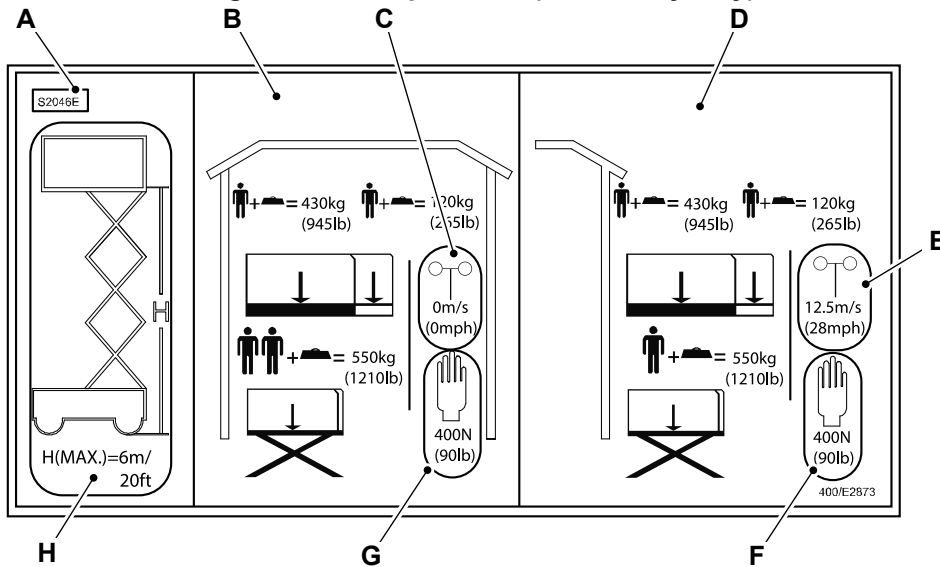
### Crushing and Collision Hazards

- Approved head protection must be worn by all operating and ground personnel.
- Keep hand and limbs out of the scissor arm assembly during operation and when raised for maintenance unless the safety strut is installed.
- Watch for obstructions around machine and overhead when driving. Check clearance above, to sides, at bottom of machine when lifting or lowering the platform.
- Always post a lookout when driving in areas where vision is obstructed.
- Keep non-operating personnel at least 1.8m away from machine during all operations.
- Under all travel conditions, the operator must limit travel speed according to conditions of the ground surface, congestion, visibility, slope, location of personnel, and other factors.
- Be aware of stopping distances in all drive speeds.
- Exercise extreme caution at all times to prevent obstacles from striking or interfering with operating controls and persons in the platform.
- Ensure that operators of other overhead and floor level machines are aware of the aerial work platform's presence. Disconnect power to overhead cranes. Barricade floor area if necessary.
- Do not operate over ground personnel. Warn personnel not to work, stand, or walk under a raised platform. Position barricades on the floor as necessary.

### Platform Information Decals

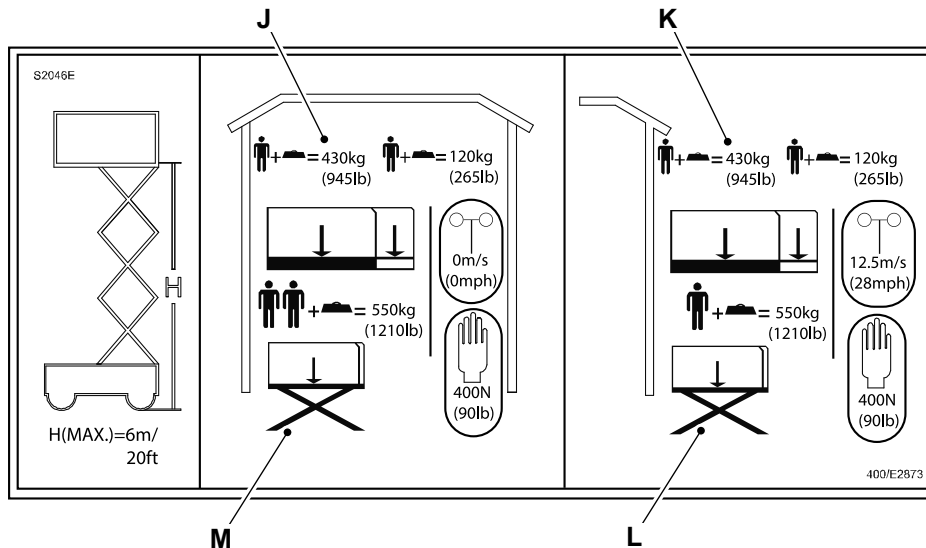
The decals are located at the backboard of the platform.

**Figure 17. Example Decal (values may vary)**



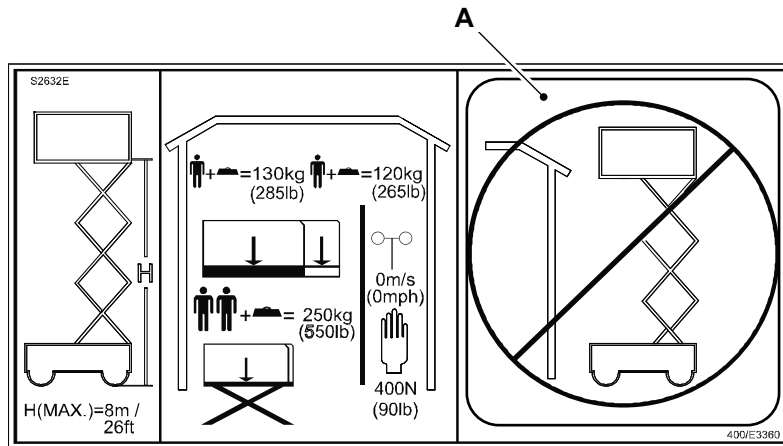
- |                               |                                  |
|-------------------------------|----------------------------------|
| <b>A</b> Machine model        | <b>B</b> Indoor rating           |
| <b>C</b> Maximum wind speed   | <b>D</b> Outdoor rating          |
| <b>E</b> Maximum wind speed   | <b>F</b> Maximum manual force    |
| <b>G</b> Maximum manual force | <b>H</b> Maximum platform height |

**Figure 18. Example Decal (values may vary)**



- |  |  |
|--|--|
| <b>J</b> Weight distribution on the extended platform  | <b>K</b> Weight distribution on the extended platform  |
| <b>L</b> Weight distribution on the retracted platform | <b>M</b> Weight distribution on the retracted platform |

**Figure 19. Example Decal (values may vary)**

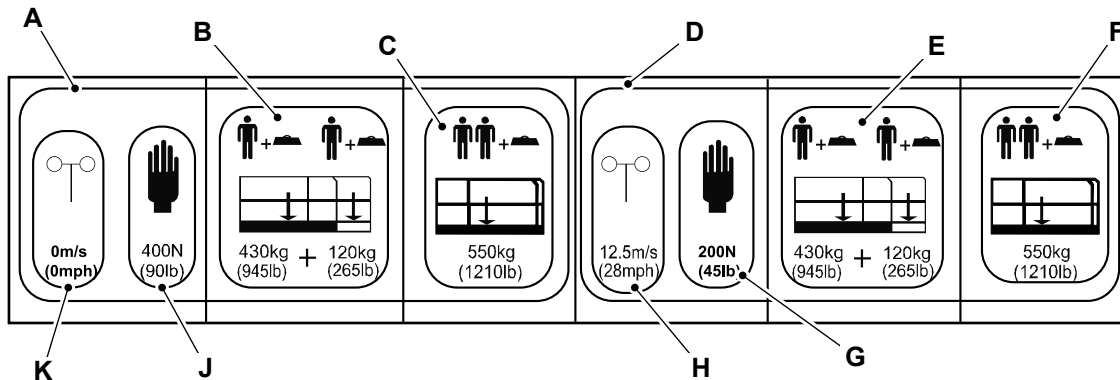


**A** Not suitable for outdoor use

The decals are located at the entry point of the platform.

For correct values refer Technical Data.  
 Refer to: [Technical Data \(PIL 01-48-12\)](#).

**Figure 20. Example Decal (values may vary)**



**A** Indoor rating (at 0m/s wind speed)

**B** Weight distribution on the extended platform

**C** Weight distribution on the retracted platform

**D** Outdoor Rating (at 12.5m/s wind speed)

**E** Weight distribution on the extended platform

**F** Weight distribution on the retracted platform

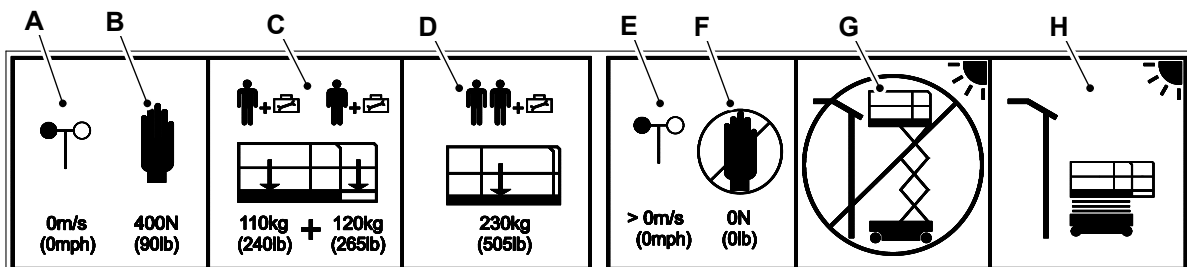
**G** Maximum manual force

**H** Wind speed

**J** Maximum manual force

**K** Wind speed

**Figure 21. Example Decal (values may vary)**



- A** Wind speed
- C** Weight distribution on the extended platform
- E** Wind speed
- G** Raised platform not suitable for outdoor use (with > 0m/s wind)
- B** Maximum manual force indoors (with 0m/s wind)
- D** Weight distribution on the retracted platform
- F** Maximum manual force outdoors (with > 0m/s wind)
- H** Fully lowered platform only may be driven outside (with > 0m/s wind)

### **Power to Platform**

- Maximum extension lead length from power to platform connectors to external power supply should not be more than 10m.
- Connect power to platform only to an external power supply with suitable RCD (Residual Current Device) rated 30 mA as per EN 60204-1-2019, Chapter 15.1 or BS 7671:2018 Regulation 411.3.3.

## Operation

**▲ WARNING** Watch for obstructions around machine and overhead when driving. Check clearance above, to sides, at bottom of machine when lifting or lowering the platform.

**WARNING** Keep hands and arms out of the path of the scissor arms when lowering the platform.

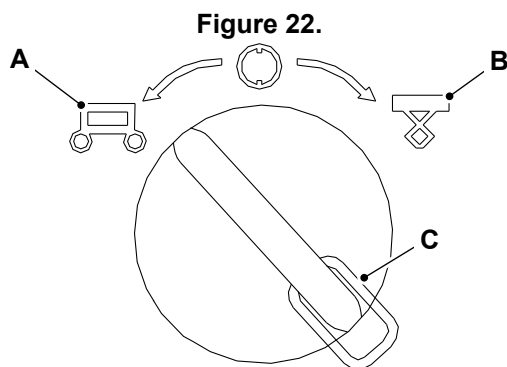
**WARNING** Do not use the platform controller to release the platform when it is stuck, snagged or caught. In this case, use the ground controller only when there are no persons on the platform.

**CAUTION** Do not raise platform with the guardrails folded down. The guardrails must be in their upright positions and properly secured when raising the platform.

### Raising and Lowering the Platform

#### Operation from the Ground

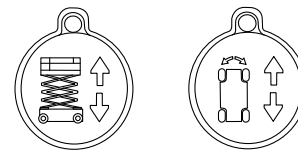
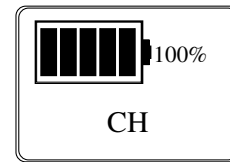
1. Turn the key switch to chassis control. Refer to Figure 22.



- A Chassis position
- B Platform position
- C Key switch

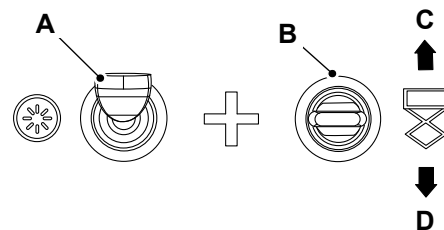
2. Make sure the ground and platform emergency stop buttons are pulled out.
3. Once chassis control mode is selected, the platform controller will show "CH" on display. Refer to Figure 23.

Figure 23.



4. Before trying to operate any controls, wait until the green LED (Light Emitting Diode) on platform controller turns solid, so that the machine can complete its start-up checks.
5. If there are any codes generated on the display, contact your nearest JCB dealer.
6. Press and hold the enable switch and move the toggle switch up to raise the platform. Refer to Figure 24.
7. Press and hold the enable switch and move the toggle switch down to lower the platform. Refer to Figure 24.

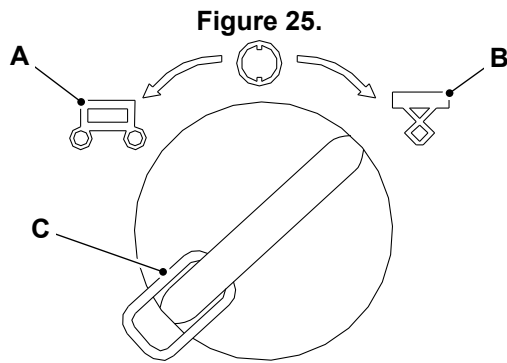
Figure 24.



- A Enable switch
- B Platform raise and lower toggle switch
- C Platform raising
- D Platform lowering

#### Operation from the Platform

1. Turn the key switch to platform control.



- A Chassis position
- B Platform position
- C Key switch

2. Make sure the ground and platform emergency stop buttons are pulled out.
3. Before trying to operate any controls, wait until the green LED at platform controller turns solid, so that the machine can complete its start-up checks.
4. If there are any codes generated on the display, contact your nearest JCB dealer.
  - 4.1. After machine startup - Drive/Lift LEDs will blink continuously indicating neutral mode. After mode selection LED will turn to solid for the selected mode and other will be off.
  - 4.2. After specified duration of inactivity the controller goes back to neutral mode and mode needs to be reselected for operation.
 

Duration: 10s
5. Press the raise/lower mode button on the platform controller. The button should illuminate.
6. Press and hold the enable switch. Refer to Figure 24.

7. Move the joystick forwards or backwards. Check the arrow colours on the joystick with the operating direction. Move forwards to lower the platform. Move backwards to raise the platform.
8. When lowering the platform the platform will stop part way down for safety. Release the joystick and check there are no obstructions in the scissors. Move the joystick down again to fully lower the platform. There maybe an intentional delay after the stop and after the joystick is pressed during lowering. Some models may not have this feature. For more details of this feature refer to 'Downward Decent Delay'.
  - 8.1. Intentional delay periods after the stop.
 

Duration: 3s
  - 8.2. Intentional delay after the joystick is pressed during lowering.
 

Duration: 1.5s

### Downward Decent Delay

When the platform is being lowered from above the decent delay height, the platform will automatically stop at the decent delay height. Refer to Table 6. Refer to Figure 26. An alarm will sound and lowering will be prevented. To continue lowering, the joystick/switch must be released, and re-activated. Refer to Figure 27. There will be a 3s delay, while the alarm continues, before the machine begins to lower. Continue to hold the joystick/switch during this delay. Refer to Figure 28.

When the platform is within the decent delay height, the decent delay also applies. When the joystick/switch is pressed to lower the platform, there will be a 3s delay, while the alarm continues, before the machine begins to lower. Continue to hold the joystick/switch during this delay. Refer to Figure 28.

Table 6. Platform Height at Downward Decent Delay

Model	S1932 EDRV	S2632 EDRV	S2646 EDRV	S3246 EDRV	S4046 EDRV	S4550 EDRV
Decent delay height	2.1m	2.4m	2.2m	2.6m	2.9m	3m

Figure 26.

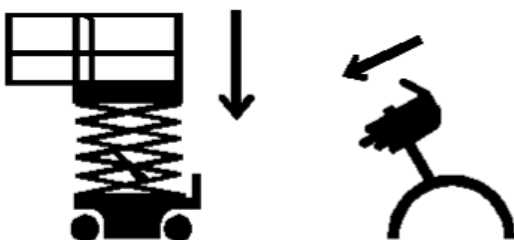


Figure 27. Release

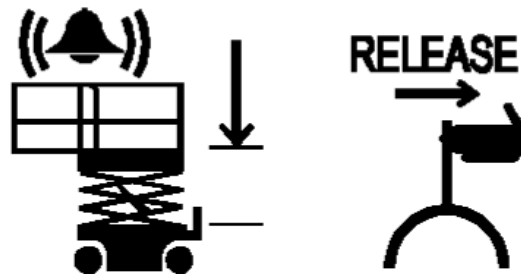
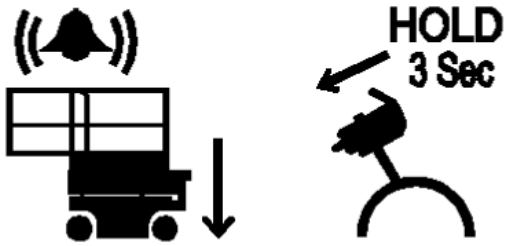


Figure 28. Hold



### Operation in Raised Position

The automatic pothole protection system folds down and drive speed is reduced when the platform is at or above descent delay height.

JCB © CONNOR STANMORE - 13/03/2026 07:57.

## Check (Operation)

You must check the machine and platform for correct operation at regular intervals.

Refer to: PIL 78-24.

## Raising and Lowering Platform

1. Make the machine safe.  
Refer to: PIL 01-03-27.
2. Park the machine in a solid and even test area free from any obstructions.
3. Pull out the ground emergency stop button to the ON position.
4. Pull out the platform emergency stop button to the ON position.
5. Turn the ignition switch to ground control position.
6. Raise the platform to its maximum height.
7. Make a note of the duration required for raising the platform.
8. Make sure that the duration is within the specified limits.  
Refer to: PIL 01-48.
9. Lower the platform to its stowed position.
10. Make a note of the duration required for lowering the platform.
11. Make sure that the duration is within the specified limits.  
Refer to: PIL 01-48.

## Driving

Make a note of the following.

- The correct drive function is necessary for safe machine operation.
- The drive function must respond quickly and smoothly to operator control.
- The drive performance must be free of hesitation, jerking and unusual noise over the entire proportionally controlled speed range.
- Do this procedure with the machine on a firm, level surface that is free of obstructions.

You must check the platform for correct operation in three different modes as follows.

## At fast speed and platform in lowered position

1. Make the machine safe with the platform lowered.  
Refer to: PIL 01-03-27.
2. Put marks on the ground for start and finish lines. Make sure that the distance between the lines is as specified.  
Distance: 10m
3. Turn the ignition switch to platform control position.
4. Pull out the ground emergency stop button to the ON position.
5. Pull out the platform emergency stop button to the ON position.
6. Make a note of the point on the machine (contact patch of a tyre) as a visual reference when you cross the test line.
7. Make sure that the low drive speed light is in OFF position.
  - 7.1. If the slow drive speed light is ON, press the drive speed select button to turn OFF the slow drive speed function.
8. Press the drive function button (if installed).
9. Press and hold the drive/steer function enable switch on the control handle.
10. Move the control lever in the forward direction.
11. Bring the machine to top drive speed before you reach the start line.
12. Start the timing when the selected reference point on the machine crosses the start line.
13. Continue at full speed and note the time when your reference point on the machine passes the finish line.
14. Make sure that the values are within the specified limits.  
Refer to: PIL 01-48.

## At slow speed and platform in lowered position

1. Make the machine safe with platform lowered.  
Refer to: PIL 01-03-27.
2. Put marks on the ground for start and finish lines. Make sure that the distance between the lines is as specified.  
Distance: 10m

3. Turn the ignition switch to platform control position.
4. Pull out the ground emergency stop button to the ON position.
5. Pull out the platform emergency stop button to the ON position.
6. Make a note of the point on the machine (contact patch of a tyre) as a visual reference when you cross the test line.
7. Make sure that the low drive speed light is in ON position.
  - 7.1. If the slow drive speed light is OFF, press the drive speed select button to turn ON the slow drive speed function.
8. Press the drive function button (if installed).
9. Press and hold the drive/steer function enable switch on the control handle.
10. Move the control lever in the forward direction.
11. Bring the machine to top drive speed before you reach the start line.
12. Start the timing when the selected reference point on the machine crosses the start line.
13. Continue at full speed and note the time when your reference point on the machine passes the finish line.
14. Make sure that the values are within the specified limits.  
[Refer to: PIL 01-48.](#)
6. Raise the platform to the specified height above the ground.  
Distance: 1.5m
7. Make sure that pothole protection system starts to work.
8. Make a note of the point on the machine (contact patch of a tyre) as a visual reference when you cross the test line.
9. Press the drive function button (if installed).
10. Press and hold the drive/steer function enable switch on the control handle.
11. Move the control lever in the forward direction.
12. Bring the machine to top drive speed before you reach the start line.
13. Start the timing when the selected reference point on the machine crosses the start line.
14. Continue at full speed and note the time when your reference point on the machine passes the finish line.
15. Calculate the speed of the machine.
16. Make sure that the speed is as specified limits.  
[Refer to: PIL 01-48.](#)

### At platform in raised position

When the platform is raised, the machine automatically goes to the slow speed mode.

1. Make the machine safe.  
[Refer to: PIL 01-03-27.](#)
2. Put marks on the ground for start and finish lines. Make sure that the distance between the lines is as specified.  
Distance: 10m
3. Turn the ignition switch to platform control position.
4. Pull out the ground emergency stop button to the ON position.
5. Pull out the platform emergency stop button to the ON position.

### Check Machine for Lateral Operation

1. Drive two side wheels up on to a suitable ramp so that the sideways chassis angle is as specified.  
Angle: 1.5°
2. Raise the platform with the ground controller.
3. Make sure that the platform automatically stops when the limit switch is released.
4. If necessary, calibrate the tilt sensor.  
[Refer to: Calibrate \(PIL 33-84-60\).](#)
5. Repeat this procedure for the other side.

### Check Machine for Longitudinal Operation

1. Drive two front wheels up on a suitable ramp so that the lengthways chassis angle is as specified.  
Angle: 3°
2. Raise the platform with the ground controller.
3. Make sure that the platform automatically stops when the limit switch is released.
4. If necessary, calibrate the tilt sensor.  
[Refer to: Calibrate \(PIL 33-84-60\).](#)



5. Repeat this procedure for the rear side.

## Calibrate

### Special Tools

Description	Part No.	Qty.
Tilt sensor calibration lead	400/J2673	1

If any component or part is changed on this machine, it is recommended to calibrate full machine in the specified sequence only. Refer to Table 7.

**Table 7. Machine Calibration Sequence**

Sequence	Check	Description
1	Angle sensor mounting position	Check the angle sensor. Check if the angle sensor bracket is mounted properly with angle sensor position at 45° angle ( fully tilted in bracket slot).
2	Tilt sensor calibration	As per procedure given below.
2.1	Lateral tilt test	Drive machine on 1.6° ramp such that machine is tilted laterally. LL error should occur.
2.2	Longitudinal tilt test	Drive machine on 3° ramp in forward and reverse. LL error should occur.
3	Descent delay height	Check the first descent limit automatically stops the platform descent from height. If the height is not in correct range, adjust it by varying the descent height parameter inside PCU menu height setting option. The value is shown as percentage of angle sensor. Reducing this value will reduce the descent height and vice versa.
4	Pot hole protection system	Check the pot hole protection system is deployed as the platform is raised both side.
4.1	Pot hole protection system	Pot hole switch check securely mounted.
5	Lower limit switch	Block the pothole guard and raise the platform from base and check the height at which DTC56 comes. This is the initial or preset height of down limit switch. Adjust the down limit switch using down limit switch screw and re-check the preset height again. Turning the down limit switch screw in clockwise direction from top will increase the height and vice versa.
5.1	Lower limit switch	Setting of lower limit switch in ECU (Electronic Control Unit) as per procedure given below.
6	Upper limit switch	Check the higher limit switch. Position it such that the motor should stop on maximum limit height.
6.1	Upper limit switch check	As per Model specification with +/- 1 inch.
7	No load calibration	As per procedure given below.
7.1	Structural check - No load	Raise and lower the platform to full working height 5 cycles with no load in the platform. Visual check for no evidence of structural damage /weakness in the scissor pack and hydraulic cylinder.
8	Full load calibration	As per SOP with 102% Rated Load.
8.1	Overload alarm check	Overload alarm should not activate at 95% load, but must activate at 105% load.

Sequence	Check	Description
8.2	Structural check - Full Load	Raise and lower the platform to full working height 5 cycles with full rated load in the platform. Visual check for no evidence of structural damage /weakness in the scissor pack and hydraulic cylinder.
9	Ascent / Descent speeds	On elevated with unladen descent speed unladen Orifice / Restrictor change.
10	Travel speed	Check and record maximum travel speed in Tortoise, Hare and elevated condition (eg. for S1932E above 2.1m it should be less than 0.8km/h (0.5mph) [10m distance in not less than 45 -0/+5s ].
10.1	Stopping distance test	The brake function must operate smoothly, free of hesitation, jerking and unusual noise and should come to complete stop on flat ground. Braking distance should not be more than 1m (testing to be done on hare mode).
11	Gradeability test	Check the machine can drive on 25% ramp.
11.1	Parking brake test	Check the parking brake holds the machine on 25% ramp.
12	Manual descent lever	Check the manual descent level is fully functional by lowering the machine with manual descent lever. Before operation, ensure the machine and surrounding area is safe to operate.
13	Hydraulic leak	Check for any hydraulic oil leaks.
14	Clear fault history	If necessary, delete all fault history.

### Angle Sensor Check (for S1932E EDRV)

Do the following steps to check angle sensor is working correctly.

If load sensing system is not calibrated, disable the load sensing in PCU.

[Refer to: Calibrate \(PIL 33-24-05\).](#)

1. Make the machine safe in raised position.  
[Refer to: PIL 01-03-27.](#)
2. Turn on the machine.
3. Get access to the angle sensor.  
[Refer to: PIL 33-84-63.](#)
4. Ensure plastic boss is not damaged and metal washer is placed behind the boss.
5. Ensure roll pin is fitted on angle sensor mounting pin of scissor pack.
6. Ensure angle sensor is mounted at 45 deg angle (fully rotated in mounting bracket).
7. If calibration is not performed, scissor pack can be moved up or down from the base position. Lift/ lower will not be allowed from PCU till complete calibration is not performed.

### Angle Sensor Check (for S2632E EDRV, S2646E EDRV, S3246E EDRV, S4046E EDRV, S4550E EDRV)

Do the following steps to check angle sensor is working correctly.

If load sensing system is not calibrated, disable the load sensing in PCU.

[Refer to: Calibrate \(PIL 33-24-05\).](#)

1. Make the machine safe in raised position.  
[Refer to: PIL 01-03-27.](#)
2. Turn on the machine.
3. Get access to the angle sensor.  
[Refer to: PIL 33-84-63.](#)
4. Ensure plastic boss is not damaged and metal washer is placed behind the boss.
5. Ensure roll pin is fitted on angle sensor mounting pin of scissor pack.
6. Check the angle sensor mounting bracket is properly fixed.
7. Ensure angle sensor is mounted at 45 deg angle (fully rotated in mounting bracket).

8. If calibration is not performed, scissor pack can be moved up or down from the base position. Lift/lower will not be allowed from PCU till complete calibration is not performed.

### Tilt Sensor Check

Do the following steps to check tilt sensor is working correctly.

If load sensing system is not calibrated, disable the load sensing in PCU.

Refer to: [Calibrate \(PIL 33-24-05\)](#).

1. Important: It is safety critical that the level of the ground is confirmed as flat during this calibration.
2. Make the machine safe with the platform raised.  
Refer to: [PIL 01-03-27](#).
3. When the machine is on level ground (specified angle in each direction), do the following.  
Angle: 0°
  - 3.1. Connect the tilt sensor calibration lead to the specified power supply.  
Voltage: 24V  
Special Tool: [Tilt sensor calibration lead \(Qty.: 1\)](#)
  - 3.2. Allow the lead to be connected with power supply for the specified duration.  
Duration: 3–7s
  - 3.3. This sets the zero position.
4. Disconnect the tilt sensor calibration lead from the power source.
  - 4.1. The green colour LED (Light Emitting Diode) must blink.

Figure 29.



A Spare cable

Do the following steps to check tilt sensor is qualified on the X-axis.

1. Put the right side machine tyres on blocks so that the machine is at specified angle to the ground.  
Angle: 1.6°
2. Put the machine to ground control mode.
3. Raise the platform.
  - 3.1. If the machine stops above the down limit height, the tilt sensor qualifies on X-axis.
4. Put the machine to platform control mode.
  - 4.1. Make sure that the error code 'LL' is displayed and alarm sounds.
5. Do the steps 1 to step 4.1 on the left side.

Do the following steps to check tilt sensor is qualified on the Y-axis.

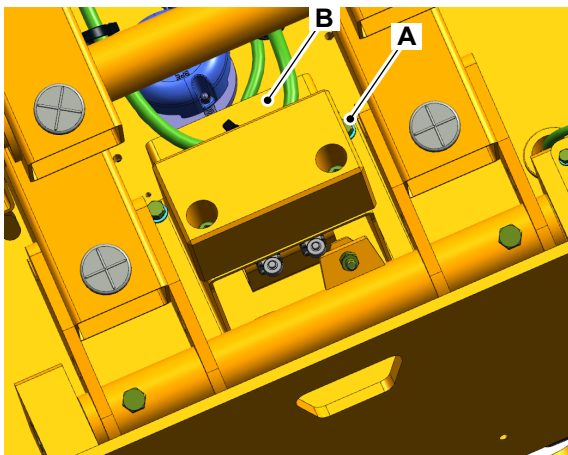
1. Put the front machine tyres on blocks so that the machine is at specified angle to the ground.  
Angle: 3.1°
2. Put the machine to ground control mode.
3. Raise the platform.

- 3.1. If the machine stops above the down limit height, the tilt sensor qualifies on X-axis.
4. Put the machine to platform control mode.
  - 4.1. Make sure that the error code 'LL' is displayed and alarm sounds.
5. Do the steps 1 to step 4.1 on the rear side.

### Platform Down Limit Height Setting

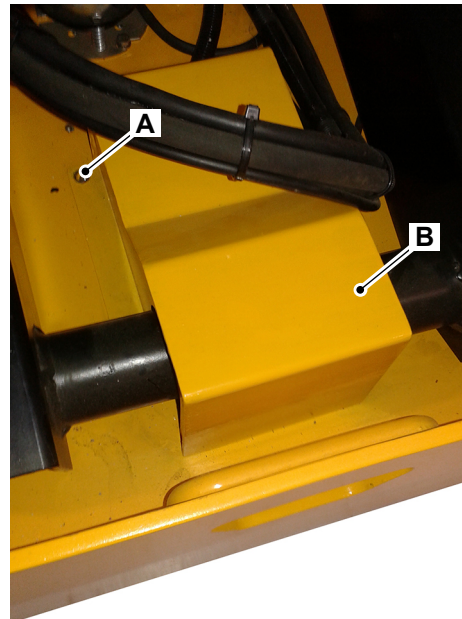
1. Make the machine safe.  
[Refer to: PIL 01-03-27.](#)
2. Lower the platform to the stowed position.
3. Make sure that there is no load on the platform.
4. Block the pothole guard using a wooden log.
5. Raise the platform from base switches till DTC 56 is triggered.
6. Measure the platform height.
  - 6.1. This should identify the switching position of the down limit switch.
  - 6.2. Remove the screw 1 (x4).
  - 6.3. Remove the bracket to access the platform down limit switch.

**Figure 30. For S1932E EDRV**



- A** Screw 1 (x4)
- B** Bracket

**Figure 31. For S2632E EDRV, S2646E EDRV, S3246E EDRV, S4046E EDRV, S4550E EDRV**



- A** Screw 1 (x4)
- B** Bracket

7. Adjust the down limit switch up or down position according to the platform height.
8. Set the down limit switch position as follows.
  - 8.1. Adjust the cam position to increase or decrease the switching position of the down limit switch according to the platform height.  
[Refer to Table 7.](#)
  - 8.2. Moving the down limit switch screw upwards will reduce the height and vice versa.
  - 8.3. Do the steps 2 to step 8.1 until the correct lower limit is set.
9. Unblock the pothole guard after the correct lower limit is set.

**Table 8. Down Limit Height**

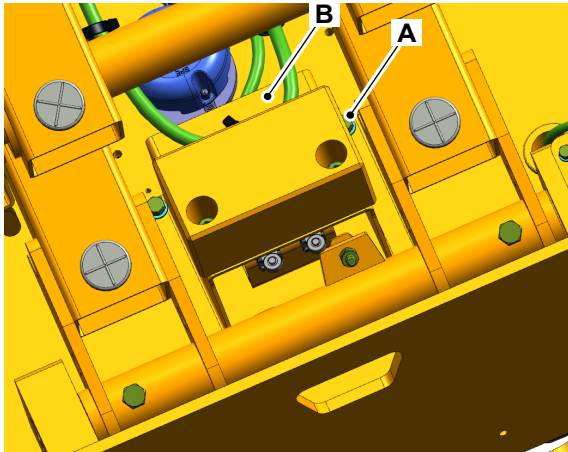
Machine Model	Down Limit Height <sup>(1)</sup>
S1932E EDRV	1.6–1.8m
S2632E EDRV	2.2–2.4m
S2646E EDRV	2.2–2.4m
S3246E EDRV	2.4–2.6m
S4046E EDRV	2.5–2.7m
S4550E EDRV	2.7–2.9m

*(1) Make a note that the heights are measured from the ground to the base of the platform.*

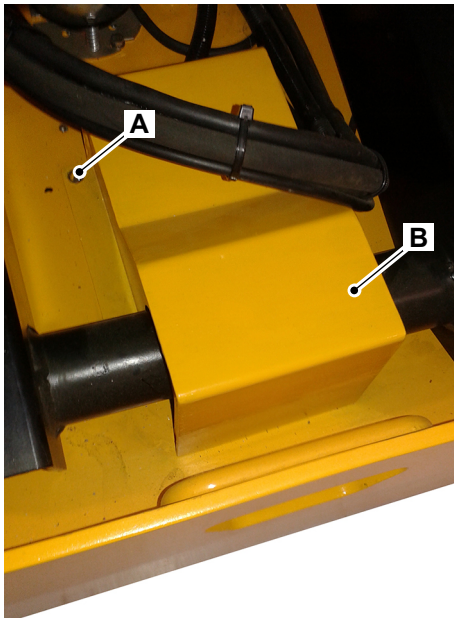
### Platform Upper Limit Height Setting

1. Make the machine safe.  
[Refer to: PIL 01-03-27.](#)

2. Raise the platform to full extension of the lift cylinder.
3. Remove the screw 1 (x4). Refer to Figure 32. Refer to Figure 33.
4. Remove the bracket to access the platform upper limit switch. Refer to Figure 32. Refer to Figure 33.

**Figure 32. For S1932E EDRV**


- A Screw 1 (x4)
- B Bracket

**Figure 33. For S2632E EDRV, S2646E EDRV, S3246E EDRV, S4046E EDRV, S455E0 EDRV**


- A Screw 1 (x4)
- B Bracket

5. Turn the upper limit switch screw in clockwise direction from top to fully release the limit switch plunger.
6. Lift the platform to the specified height. Refer to Table 9.

7. Turn the upper limit switch screw in counterclockwise direction from top to engage the limit switch plunger.

8. If 'DTC 5A' occurs, lower the platform manually by specified height.

Length: 1m

- 8.1. Turn ON the machine.

- 8.2. Lift the platform to verify the height where motor stops.

9. If 'DTC 5A' does not occur, proceed with step 10.

10. Turn ON the machine, lower the machine by specified height, and lift the platform to verify the height where motor stops.

Length: 1m

11. Adjust the upper limit switch screw clockwise or counterclockwise and repeat step 10 to make sure that the specified upper limit height is achieved.

12. Tighten the upper limit switch screw to the correct torque value.

13. If motor does not stop, check and make sure that the upper limit switch connections are in correct order.

Refer to: PIL 33-00-50.

**Table 9. Upper Limit Height**

Machine Model	Upper Limit Height <sup>(1)</sup>
S1932E EDRV	18ft-8in to 18ft-10in
S2632E EDRV	25ft-11in to 26ft-1in
S2646E EDRV	25ft-11in to 26ft-1in
S3246E EDRV	31ft-9in to 31ft-11in
S4046E EDRV	38ft-11in to 39ft-1in
S4550E EDRV	45ft-2in to 45ft-4in

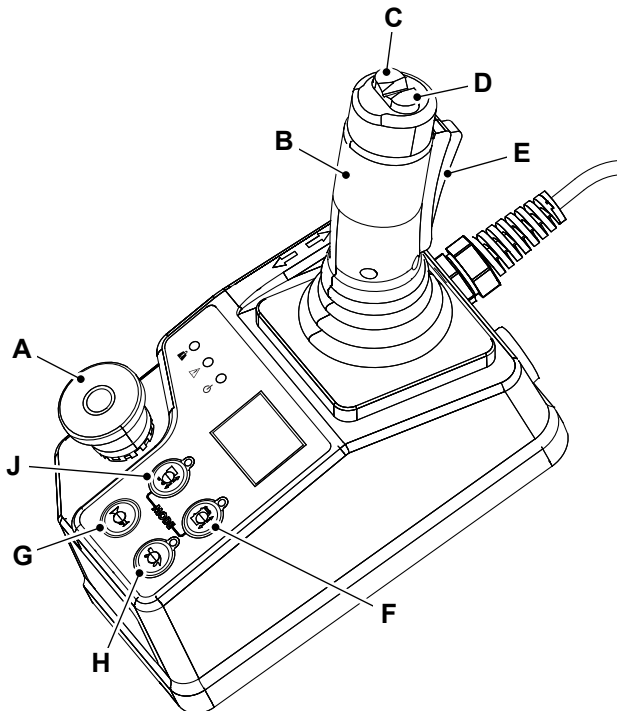
(1) Make a note that the heights are measured from the ground to the base of the platform.

### Diagnostic Menu

1. Press the Lift Mode and Drive Mode button of PCU together while startup. Refer to Figure 34.

1.1. PCU will enter into the diagnostic menu.

2. Button configuration to navigate the diagnostic menu is as follows Refer to Figure 34. -

**Figure 34.**


- A** Emergency stop switch
- B** Joystick (forwards/backwards)
- C** Turn left switch
- D** Turn right switch
- E** Safety trigger/enable switch
- F** Drive mode
- G** Horn button
- H** Tortoise mode
- J** Lift mode

- 2.1. Lift mode - UP
- 2.2. Horn button - DOWN
- 2.3. Drive mode - ENTER
- 2.4. Tortoise mode - BACK
- 2.5. Turn left switch - Value increment
- 2.6. Turn right switch - Value decrement
- 2.7. Safety trigger/enable switch - Cursor position change left to right

### Angle Sensor Calibration

Make sure to connect the joystick to the datalink interconnect inside the RH door.

1. The machine will be raised to the full height during the calibration procedure.
  - 1.1. Make sure that there is sufficient clearance above the platform before starting the calibration.
2. The calibration can be interrupted if there is a hazardous event by pressing an emergency stop.

3. Any button pressed outside of this time frame will nullify the sequence and require starting from the beginning.
4. Machine lift/lower operation from PCU will not work until machine is fully calibrated. Use base controls for lifting and lowering operations.
5. Take the machine to a suitable testing area.
6. Lower the platform to the stowed position.
7. Make sure that there is no load on the platform.
8. Make sure that the both (base and PCU) emergency switches are in the ON position.
9. Press the lift and travel button together on the PCU while switching ON the key to the platform control position.
10. The PCU LCD (Liquid Crystal Display) will display 'Menu'.
11. Select 'OEM settings' and press enter.
12. You will be asked to enter the password.
  - 12.1. Contact JCB service for password.
13. Move the platform raise/lower toggle switch to find 'Cal settings' function.
14. Press the enter button.
15. Scroll down and select 'Angle sensor', and press enter.
16. Select ON by pressing the left/right button for the angle sensor calibration and press enter.
17. Wait for the green light to blink once.
  - 17.1. Scroll up to enable and change the status to ON, and press enter.
18. Wait for the green light to blink.
  - 18.1. The calibration will start automatically and platform will move up and down twice.
19. Once the calibration is done, perform the key cycle to save the calibration.

### No Load Static Calibration

Make sure to connect the joystick to the datalink interconnect inside the RH door.

1. The machine will be raised to the full height during the calibration procedure.
  - 1.1. Make sure that there is sufficient clearance above the platform before starting the calibration.

2. The calibration can be interrupted if there is a hazardous event by pressing an emergency stop.
  3. Any button pressed outside of this time frame will nullify the sequence and require starting from the beginning.
  4. Take the machine to a suitable testing area.
  5. Lower the platform to the stowed position.
  6. Make sure that there is no load on the platform.
  7. Make sure that the both (base and PCU) emergency switches are in the ON position.
  8. Press the lift and travel button together on the PCU while switching ON the key to the platform control position.
  9. The PCU LCD will display 'Menu'.
  10. Select 'OEM settings' and press enter.
  11. You will be asked to enter the password.
    - 11.1. Contact JCB service for password.
  12. Move the platform raise/lower toggle switch to find 'Cal settings' function.
  13. Press the enter button.
  14. Scroll down and select 'NL Static', and press enter.
  15. Select ON by pressing the left/right button for the no load static calibration and press enter.
  16. Wait for the green light to blink once.
    - 16.1. Scroll up to enable and change the status to ON, and press enter.
  17. Wait for the green light to blink.
    - 17.1. The calibration will start automatically. Platform will move up and down once, and stop in between 25 times each cycle to save data.
  18. Once the calibration is done, perform the key cycle to save the calibration.
    - 18.1. If the calibration result shows errors, check error code and inspect condition of the corresponding sensors for correct working and do the calibration process again.
- 
1. The machine will be raised to the full height during the calibration procedure.
    - 1.1. Make sure that there is sufficient clearance above the platform before starting the calibration.
  2. The calibration can be interrupted if there is a hazardous event by pressing an emergency stop.
  3. Any button pressed outside of this time frame will nullify the sequence and require starting from the beginning.
  4. Take the machine to a suitable testing area.
  5. Lower the platform to the stowed position.
  6. Make sure that there is no load on the platform.
  7. Make sure that the both (base and PCU) emergency switches are in the ON position.
  8. Press the lift and travel button together on the PCU while switching ON the key to the platform control position.
  9. The PCU LCD will display 'Menu'.
  10. Select 'OEM settings' and press enter.
  11. You will be asked to enter the password.
    - 11.1. Contact JCB service for password.
  12. Move the platform raise/lower toggle switch to find 'Cal settings' function.
  13. Press the enter button.
  14. Scroll down and select 'NL Dynamic', and press enter.
  15. Select ON by pressing the left/right button for the no load dynamic calibration and press enter.
  16. Wait for the green light to blink once.
    - 16.1. Scroll up to enable and change the status to ON, and press enter.
  17. Wait for the green light to blink.
    - 17.1. The calibration will start automatically. Platform will move up and down 2 times continuously.
  18. Once the calibration is done, perform the key cycle to save the calibration.
    - 18.1. If the calibration result shows errors, check error code and inspect condition of the corresponding sensors for correct working and do the calibration process again.

### No Load Dynamic Calibration

Make sure to connect the joystick to the datalink interconnect inside the RH door.

## Full Load Static Calibration

1. The machine will be raised to full height during the calibration procedure.
2. Make sure that there is sufficient clearance above the platform before starting the calibration.
3. The calibration can be interrupted if there is a hazardous event by pressing an emergency stop.
4. Any button pressed outside of this time frame will nullify the sequence and require starting from the beginning.
5. Take the machine to suitable testing area.
6. Lower the platform to the stowed position.
7. Make sure that the platform is loaded to the 102% of rated load on the platform. [Refer to Table 10.](#)
8. Make sure that the both (Base and PCU) emergency switches are in 'ON' Position.
9. Press the lift and travel button together on PCU while switching on the key to platform control position.
10. The LCD will display 'Menu'.
11. Select 'OEM settings' and press enter
12. You will be asked to enter the password.
  - 12.1. Contact JCB service for password.
13. Move the platform raise/lower toggle switch to find 'Cal settings' function.
14. Press the enter button.
15. Scroll down and select 'Full load static', press enter.
16. Now that the 'OFF / ON' text is highlighted, change it to 'ON' position by pressing the left/right button. Press enter.
17. Wait for the green light to blink once. Scroll up to enable and change the status to 'ON' and press enter.
18. Wait for the green light to blink.
  - 18.1. The calibration will start automatically. Platform will raise and lower 2 times while stopping 25 times each cycle.
19. Once the calibration is done, perform the key cycle to save the calibration.
  - 19.1. If the calibration result shows errors, check error code and condition of the

sensors for correct working and do the calibration process again.

## Full Load Dynamic Calibration

1. The machine will be raised to full height during the calibration procedure.
2. Make sure that there is sufficient clearance above the platform before starting the calibration.
3. The calibration can be interrupted if there is a hazardous event by pressing an emergency stop.
4. Any button pressed outside of this time frame will nullify the sequence and require starting from the beginning.
5. Take the machine to suitable testing area.
6. Lower the platform to the stowed position.
7. Make sure that the platform is loaded to the 102% of rated load on the platform. [Refer to Table 10.](#)
8. Make sure that the both (base and PCU) emergency switches are in 'ON' position.
9. Press the lift and travel button together on PCU while switching on the key to platform control position.
10. The LCD will display 'menu'.
11. Select 'OEM settings' and press enter.
12. You will be asked to enter the password.
  - 12.1. Contact JCB service for password.
13. Move the platform raise/lower toggle switch to find 'Cal settings' function.
14. Press the enter button.
15. Scroll down and select 'Full load Dynamic', press enter.
16. Now that the 'OFF / ON' text is highlighted, change it to 'ON' position by pressing the left/right button. Press enter.
17. Wait for the green light to blink once. Scroll up to enable and change the status to 'ON' and press enter.
18. Wait for the green light to blink.
  - 18.1. The calibration will start automatically. Platform will raise and lower 2 times continuously.
19. Once the calibration is done, perform the key cycle to save the calibration.

19.1. If the calibration result shows errors, check error code and condition of the sensors for correct working and do the calibration process again.

**Table 10. Calibration Load**

Machine Model	102% Load (Without Joystick)
S1932E EDRV	235kg
S2632E EDRV	255kg
S2646E EDRV	459kg
S3246E EDRV	326kg
S4046E EDRV	326kg
S4550E EDRV	235kg

**Table 11. Rated Load Capacity**

Machine Model	100% Rated Load
S1932E EDRV	230kg
S2632E EDRV	250kg
S2646E EDRV	450kg
S3246E EDRV	320kg
S4046E EDRV	320kg
S4550E EDRV	230kg

**Overload Calibration - Upper Side**

The machine will be raised to full height during the calibration procedure. Make sure that there is sufficient clearance above the platform before starting the calibration. The calibration can be interrupted if there is a hazardous event by pressing an Emergency Stop.

Any button pressed outside of this time frame will nullify the sequence and require starting from the beginning.

1. Take the machine to suitable testing area.
2. Raise and lower the platform twice.
3. Lower the platform to the stowed position.
4. Add 105% rated load on the platform. [Refer to Table 12.](#)
5. Raise the platform.
6. Make sure that the platform should not raise to more than 50% of full height before the overload alarm sounds.
7. When the overload alarm occurs 'OL' error is displayed on the LCD.
8. Restart the machine. Wait for specified duration.
9. Make sure that the 'OL' alarm sound again activates.

**Table 12. Overload Check Weight**

Machine Model	105% Rated Load
S1932E EDRV	242kg
S2632E EDRV	263kg
S2646E EDRV	473kg
S3246E EDRV	336kg
S4046E EDRV	336kg
S4550E EDRV	241kg

**Overload Calibration - Lower Side**

The machine will be raised to full height during the calibration procedure. Make sure that there is sufficient clearance above the platform before starting the calibration. The calibration can be interrupted if there is a hazardous event by pressing an Emergency Stop.

Any button pressed outside of this time frame will nullify the sequence and require starting from the beginning.

1. Take the machine to suitable testing area.
2. Raise and lower the platform twice.
3. Lower the platform to the stowed position.
4. Add 95% rated load on the platform. [Refer to Table 13.](#)
5. Fully raise and lower the platform.
6. Make sure that no overload alarm sounds during the test.
7. If overload alarm sounds, contact JCB Service.
8. Raise and lower the platform to full working height for 5 cycles with 95% load in the platform.
9. Visually inspect the scissor pack, platform and hydraulic cylinders for structural damage or weakness.
10. Make sure that there are no hydraulic leaks.

**Table 13. False Overload Check Weight**

Machine Model	95% Rated Load
S1932E EDRV	218kg
S2632E EDRV	237kg
S2646E EDRV	427kg
S3246E EDRV	304kg
S4046E EDRV	304kg
S4550E EDRV	218kg

**Raising and Lowering Speed**

1. Make the machine safe.  
[Refer to: PIL 01-03-27.](#)

2. Park the machine in a solid and even test area free from any obstructions.
3. Pull out the ground emergency stop button to the 'ON' position.
4. Pull out the platform emergency stop button to the 'ON' position.
5. Turn the ignition switch to ground control position.
6. Raise the platform to its maximum height.
7. Make a note of the duration required for raising the platform.
8. Make sure that the duration is within the specified limits.  
[Refer to: Technical Data \(PIL 01-48-12\).](#)
9. Lower the platform to its stowed position.
10. Make a note of the duration required for lowering the platform.
11. Make sure that the duration is within the specified limits.  
[Refer to: Technical Data \(PIL 01-48-12\).](#)
12. If the platform raising and lowering speeds are not within the range, adjust the orifice. Refer to section below.

### Orifice Change

Machines are factory set to achieve the desired lowering speed. [Refer to Table 14.](#) If required, you may change the orifice to achieve the specified speed.

1. Keep extending scissor until the lift valve easy to access for orifice fitment.
2. Install the safety strut.
3. Disconnect the battery.
4. Replace the orifice as required.  
[Refer to: PIL 30-00-50.](#)
  - 4.1. Select from the available orifices. [Refer to Table 15.](#)
  - 4.2. If the speed observed is less than specification, install the higher size orifice.
  - 4.3. If the speed observed is higher than specification, install the lower size orifice.
5. Check the lowering speed as per above procedure.
6. If the lowering speed does not change, contact the JCB Service.

**Table 14. Lowering Times (Factory Set)**

Machine Model	Lowering time @ 100% Load
S1932E EDRV	25–30s
S2632E EDRV	32–38s
S2646E EDRV	30–36s
S3246E EDRV	40–46s
S4046E EDRV	46–54s
S4550E EDRV	40–46s

**Table 15. Orifice Settings (Available Orifices)**

JCB Part Number	Orifice Diameter
443/E1220	0.9mm
443/E1221	1.5mm
443/E1222	1.8mm
443/E1223	1.3mm
443/E1224	1.6mm
443/E1225	1.2mm
443/E1226	1.1mm
443/E1227	1mm
443/E1228	1.7mm
443/E1229	1.9mm

### Decent Delay Height Setting

1. Descent delay height is preset in machine software.
2. Raise the machine to around 50% of machine height and start lowering.
3. Machine will stop mid way while lowering, measure this height.
4. This height is your pre-set Descent delay height.
5. If it does not come in standard range, you can adjust this using PCU menu.
6. Press the lift and travel button together on PCU while switching on the key to platform control position.

7. The LCD will display 'menu'.
8. Select 'OEM settings' and press enter
9. You will be asked to enter the password.
  - 9.1. Contact JCB service for password.
10. Press the up/down switch to find 'Height settings' function.
11. Press the 'ENTER' button.
12. Scroll down and select Descent Height, press enter.
13. This parameter shows angle sensor percentage at which descent height is set.
14. Adjust this parameter using scroll and up/down switch.
15. Increasing this value will increase the descent height and vice versa.
16. Press enter to save the value and recheck the height as mentioned above.

**Table 16. Decent Height Limits**

Machine Model	Descent Height Limits
S1932E EDRV	2.1 ± 0.1m
S2632E EDRV	2.4 ± 0.1m
S2646E EDRV	2.2 ± 0.1m
S3246E EDRV	2.6 ± 0.1m
S4046E EDRV	2.9 ± 0.1m
S4550E EDRV	3 ± 0.1m

**Pothole Sensor Calibration**

1. Make sure that the pothole protection system is deployed as the platform is raised.
2. Make sure that the pothole protection fault code is activated if the plates are prevented from deploying.
  - 2.1. Place a wooden wage under the pothole protection plate.
  - 2.2. Raise the platform.
  - 2.3. The error code '56' should appear and raise function should stop.
  - 2.4. Do the steps 2.1 to step 2.3 for both side plates.
3. Make sure that the pothole sensors are correctly mounted and secured.

**Machine Travel Speed Calibration**

Make a note of the following.

- The correct drive function is necessary for safe machine operation.
- The drive function must respond quickly and smoothly to operator control.
- The drive performance must be free of hesitation, jerking and unusual noise over the entire proportionally controlled speed range.
- Do this procedure with the machine on a firm, level surface that is free of obstructions.

You must check the platform for correct operation in three different modes as follows.

**At fast speed and platform in lowered position**

1. Make the machine safe with the platform lowered.
 

[Refer to: PIL 01-03-27.](#)
2. Put marks on the ground for start and finish lines. Make sure that the distance between the lines is as specified.
 

Distance: 10m
3. Turn the ignition switch to platform control position.
4. Pull out the ground emergency stop button to the 'ON' position.
5. Pull out the platform emergency stop button to the 'ON' position.
6. Make a note of the point on the machine (contact patch of a tyre) as a visual reference when you cross the test line.
7. Make sure that the low drive speed light is in OFF position.
  - 7.1. If the slow drive speed light is ON, press the drive speed select button to turn OFF the slow drive speed function.
8. Press the drive function button (if installed).
9. Press and hold the drive/steer function enable switch on the control handle.
10. Move the control lever in the forward direction.
11. Bring the machine to top drive speed before you reach the start line.
12. Start the timing when the selected reference point on the machine crosses the start line.
13. Continue at full speed and note the time when your reference point on the machine passes the finish line.
14. Make sure that the values are within the specified limits.

Refer to: [Technical Data \(PIL 01-48-12\)](#).

### At slow speed and platform in lowered position

1. Make the machine safe with platform lowered.  
Refer to: [PIL 01-03-27](#).
2. Put marks on the ground for start and finish lines. Make sure that the distance between the lines is as specified.  
Distance: 10m
3. Turn the ignition switch to platform control position.
4. Pull out the ground emergency stop button to the 'ON' position.
5. Pull out the platform emergency stop button to the 'ON' position.
6. Make a note of the point on the machine (contact patch of a tyre) as a visual reference when you cross the test line.
7. Make sure that the low drive speed light is in 'ON' position.
  - 7.1. If the slow drive speed light is OFF, press the drive speed select button to turn 'ON' the slow drive speed function.
8. Press the drive function button (if installed).
9. Press and hold the drive/steer function enable switch on the control handle.
10. Move the control lever in the forward direction.
11. Bring the machine to top drive speed before you reach the start line.
12. Start the timing when the selected reference point on the machine crosses the start line.
13. Continue at full speed and note the time when your reference point on the machine passes the finish line.
14. Make sure that the values are within the specified limits.

Refer to: [Technical Data \(PIL 01-48-12\)](#).

### At platform in raised position

When the platform is raised, the machine automatically goes to the slow speed mode.

1. Make the machine safe.  
Refer to: [PIL 01-03-27](#).

2. Put marks on the ground for start and finish lines. Make sure that the distance between the lines is as specified.  
Distance: 10m
3. Turn the ignition switch to platform control position.
4. Pull out the ground emergency stop button to the 'ON' position.
5. Pull out the platform emergency stop button to the 'ON' position.
6. Raise the platform to the specified height above the ground.  
Distance: 1.5m
7. Make sure that pothole protection system starts to work.
8. Make a note of the point on the machine (contact patch of a tyre) as a visual reference when you cross the test line.
9. Press the drive function button (if installed).
10. Press and hold the drive/steer function enable switch on the control handle.
11. Move the control lever in the forward direction.
12. Bring the machine to top drive speed before you reach the start line.
13. Start the timing when the selected reference point on the machine crosses the start line.
14. Continue at full speed and note the time when your reference point on the machine passes the finish line.
15. Calculate the speed of the machine.
16. Make sure that the speed is as specified limits.

Refer to: [Technical Data \(PIL 01-48-12\)](#).

### Brake Test

The brakes must be able to hold the machine upto 25% slope. Refer to operators manual.

Make a note of the following.

- You must check the brakes for correct operation at regular intervals. Refer to Maintenance Schedules.
- The correct brake function is necessary for safe machine operation.
- The brake function must operate smoothly, free of hesitation, jerking and unusual noise.
- Do this procedure with the machine on a firm, level surface that is free of obstructions.

1. Make the machine safe with the platform lowered.  
[Refer to: PIL 01-03-27.](#)
2. Make sure that the platform extension is in the fully retracted position.
3. Put a mark on the ground to use as a test line.
4. Turn the ignition switch to platform control.
5. Pull out the ground emergency stop button to the 'ON' position.
6. Pull out the platform emergency stop button to the 'ON' position.
7. Make a note of the point on the machine (contact patch of a tyre) as a visual reference when you cross the test line.
8. Press the drive function button (if installed).
9. Press and hold the drive/steer function enable switch on the control handle.
10. Move the control lever in the forward direction.
11. Bring the machine to top drive speed before you reach the test line.
12. Release the control lever when the selected reference point on the machine crosses the test line.
13. Measure the distance between the test line and the machine reference point.
14. Make sure that the braking distance is within the specified limits.  
[Refer to: Technical Data \(PIL 01-48-12\).](#)
15. Raise the platform.
16. Do the steps 3 to 13 with the platform raised.
17. Make sure that the braking distance is within the specified limits.  
[Refer to: Technical Data \(PIL 01-48-12\).](#)

### Gradeability Test

Make a note that the machine will take on ramp with operator weight only in fully stowed position.

1. Start the machine on specified slope ramp from start point and slowly took upward side.
2. Hold/Park the machine on ramp for specified duration.  
Duration: 5s
  - 2.1. The Machine should stop on ramp.
3. Drive the machine on straight platform and slowly downward.
4. Hold/Park the machine on ramp for specified duration.  
Duration: 5s
  - 4.1. The Machine should stop on ramp.

### Manual Brake Release Test

1. Please refer the procedure to manually release the brakes.  
[Refer to: Operation \(PIL 24-00-00\).](#)
2. After following the manual brake release procedure, adjust the wheel chocks and manually push or pull the machine to test brakes are released.

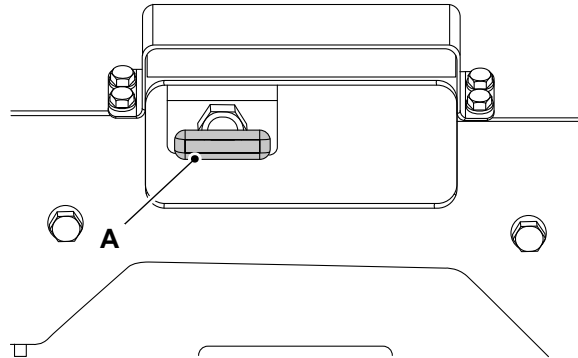
### Manual Descent Lower Test

The lowering alarm does not sound while lowering but if the machine is switched on the fault alarm will sound due to lowering without electrical controls. Lowering may continue.

To lower the platform in emergency conditions:

1. Make the machine safe.  
[Refer to: PIL 01-03-27.](#)
2. Raise the machine to full height.
3. Pull out the emergency lowering lever. [Refer to Figure 35.](#)
4. Release the lever to stop the operation.
5. Measure the lowering speed. Make sure that it is within the specified limits.  
[Refer to: Technical Data \(PIL 01-48-12\).](#)

**Figure 35.**



**A** Emergency lowering lever

### Hydraulic Leak Test

After the calibration and testing is completed, check the hydraulic system for leaks.

1. Check for signs of hydraulic oil leaks, dripping or residue on or around the following components.
  - 1.1. Hydraulic tank and filter.
  - 1.2. Gear pump and main control valve block.
  - 1.3. Cylinder rams and hydraulic hoses.
2. Replace the O-rings wherever there are leaks.
3. Replace any damaged hoses or components.
4. Tighten the hydraulic adaptors to required torque.

### Clear Fault History (If required)

1. Enter the ECU display menu.
  - 1.1. Press and hold the 'Enter' button on the ECU.
  - 1.2. Switch the machine 'ON' in the chassis control position.
  - 1.3. Release the 'Enter' button when the display changes to the menu.
2. Delete the fault history.
  - 2.1. Select and Enter the Fault History section in the display menu.
  - 2.2. When you view the Fault History, hold the 'Enter' button for specified duration until it displays 'Clear History Fault?'.  
 Duration: 5s

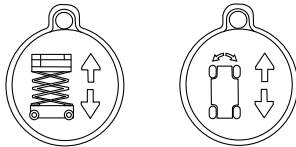
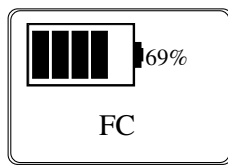
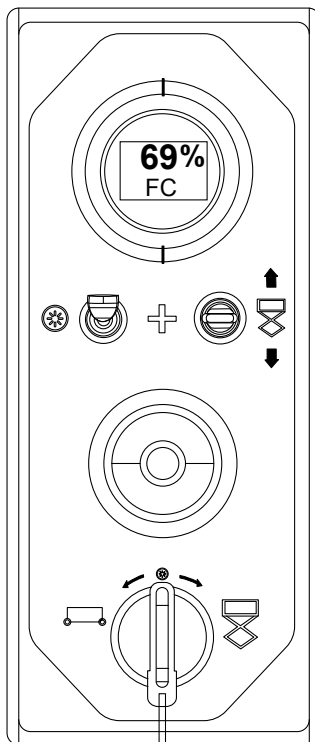
- 2.3. Hold the 'Enter' button for another specified duration to delete the fault history.  
 Duration: 5s

### Field Calibration - OPR Settings

When the load sensing system of a machine (angle sensor/pressure sensor) is repaired/reworked, field calibration can help to restore machine functionality with a de-rated capacity temporarily until the machine is fully calibrated with the rated load. Machine load capacity after field calibration will be reduced to approximately 75%-85% of the rated load.

It is always recommended to do the full calibration sequence on machine whenever required. However, in case of non-availability of the suitable weights, field calibration can be performed (lift capacity will be reduced). The machine must be calibrated as per sequence given in the specified table. [Refer to Table 7.](#)

To indicate the machine is running in no load (NL) field calibration, the platform and base display will show 'FC' while raising and lowering operation. [Refer to Figure 36.](#) [Refer to Figure 37.](#)

**Figure 36.**

**Figure 37.**


A standard calibration will restore the 100% load capacity, and 'FC' indication will no longer be visible on the platform or base control panel display.

Field calibration must be completed in one go with all the three below steps in sequence.

### Angle Sensor Calibration

1. The machine will be raised to the full height during the calibration procedure.
  - 1.1. Make sure that there is sufficient clearance above the platform before starting the calibration.

2. The calibration can be interrupted if there is a hazardous event by pressing an emergency stop.
3. Any button pressed outside of this time frame will nullify the sequence and require starting from the beginning.
4. Take the machine to a suitable testing area.
5. Lower the platform to the stowed position.
6. Make sure that there is no load on the platform.
7. Make sure that the both (base and PCU) emergency switches are in the ON position.
8. Press the lift and travel button together on the PCU while switching ON the key to the platform control position.
9. The PCU display will display 'Menu'.
10. Select 'OPR settings' and press enter.
11. Move the platform raise/lower toggle switch to select 'Field cal' function.
12. Press the enter button.
13. Scroll down and select 'Angle sensor', and press enter.
14. Select ON by pressing the left/right button for the angle sensor calibration and press enter.
15. Wait for the green light to blink once.
  - 15.1. Scroll up to enable and change the status to ON, and press enter.
16. Wait for the green light to blink.
  - 16.1. The calibration will start automatically and platform will move up and down once.
17. Once the calibration is complete, the base display will show 'FC AS OK'. Perform a key cycle to save the calibration.
18. If the calibration result shows 'FC AS NOK' error, do the steps that follow:
  - 18.1. Check the error code.
  - 18.2. Inspect the condition of the corresponding sensors to ensure correct operation.
  - 18.3. Perform the calibration process again.

### No Load Static Calibration

1. The machine will be raised to the full height during the calibration procedure.

- 1.1. Make sure that there is sufficient clearance above the platform before starting the calibration.
2. The calibration can be interrupted if there is a hazardous event by pressing an emergency stop.
  - 2.1. If field calibration is aborted for any reason, the machine will display 'FC reqd' and cannot be operated until field calibration is finished.
3. Any button pressed outside of this time frame will nullify the sequence and require starting from the beginning.
4. Take the machine to a suitable testing area.
5. Lower the platform to the stowed position.
6. Make sure that there is no load on the platform.
7. Make sure that the both (base and PCU) emergency switches are in the ON position.
8. Press the lift and travel button together on the PCU while switching ON the key to the platform control position.
9. The PCU display will display 'Menu'.
10. Select 'OPR settings' and press enter.
11. Move the platform raise/lower toggle switch to select 'Field cal' function.
12. Press the enter button.
13. Scroll down and select 'NL Static', and press enter.
14. Select ON by pressing the left/right button for the no load static calibration and press enter.
15. Wait for the green light to blink once.
  - 15.1. Scroll up to enable and change the status to ON, and press enter.
16. Wait for the green light to blink.
  - 16.1. The calibration will start automatically. The platform will raise and lower once, and then stop periodically to capture calibration data.
17. Once the calibration is complete, the base display will show 'FC NL OK'. Perform a key cycle to save the calibration.
18. If the calibration result shows 'FC NL NOK' error, do the steps that follow:
  - 18.1. Check the error code.

- 18.2. Inspect the condition of the corresponding sensors to ensure correct operation.
- 18.3. Perform the calibration process again.

### **No Load Dynamic Calibration**

1. The machine will be raised to the full height during the calibration procedure.
  - 1.1. Make sure that there is sufficient clearance above the platform before starting the calibration.
2. The calibration can be interrupted if there is a hazardous event by pressing an emergency stop.
  - 2.1. If field calibration is aborted for any reason, the machine will display 'FC reqd' and cannot be operated until field calibration is finished.
3. Any button pressed outside of this time frame will nullify the sequence and require starting from the beginning.
4. Take the machine to a suitable testing area.
5. Lower the platform to the stowed position.
6. Make sure that there is no load on the platform.
7. Make sure that the both (base and PCU) emergency switches are in the ON position.
8. Press the lift and travel button together on the PCU while switching ON the key to the platform control position.
9. The PCU display will display 'Menu'.
10. Select 'OPR settings' and press enter.
11. Move the platform raise/lower toggle switch to select 'Field cal' function.
12. Press the enter button.
13. Scroll down and select 'NL Dynamic', and press enter.
14. Select ON by pressing the left/right button for the no load dynamic calibration and press enter.
15. Wait for the green light to blink once.
  - 15.1. Scroll up to enable and change the status to ON, and press enter.
16. Wait for the green light to blink.
  - 16.1. The calibration will start automatically. The platform will raise and lower once continuously.

17. Once the calibration is complete, the base display will show 'FC NL OK'. Perform a key cycle to save the calibration.
18. If the calibration result shows 'FC NL NOK' error, do the steps that follow:
  - 18.1. Check the error code.
  - 18.2. Inspect the condition of the corresponding sensors to ensure correct operation.
  - 18.3. Perform the calibration process again.

### Rapid Calibration - OPR Settings

Machine software must be version A115 or above and joystick firmware version 00.00.29 or above to perform rapid calibration.

Rapid calibration works similar to field calibration, except the requirement of lifting the machine to full height. Machine load capacity after rapid calibration reduces to 65%-75% of the rated load.

A minimum ceiling height should be provided for smooth completion. Refer to Table 17.

Table 17.

Model	Minimum Ceiling Height Required
S1932E EDRV	3.5m
S2632E EDRV	4.5m
S2646E EDRV	4.5m
S3246E EDRV	4.5m
S4046E EDRV	4.5m
S4550E EDRV	5m

It is always recommended to do the full calibration sequence on machine whenever required. However in case of non-availability of suitable weights and ceiling height not sufficient to lift the machine to full height, rapid calibration can be performed.

To indicate the machine is running on rapid calibration, the platform and base display will show 'RC'. Refer to Figure 38. Refer to Figure 39.

Figure 38.

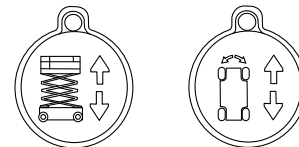
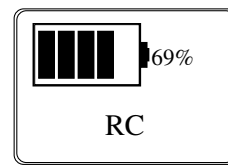
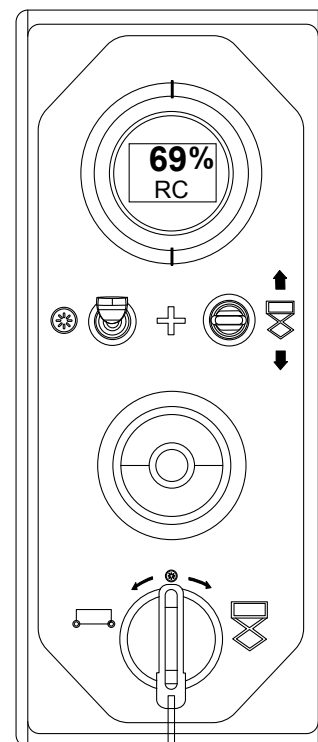


Figure 39.



The calibration can be interrupted if there is a hazardous event by pressing an emergency stop.

Any button pressed outside of this time frame will nullify the sequence and require starting from the beginning.

### Rapid Calibration

1. Take the machine to a suitable testing area.
2. Lower the platform to the stowed position.
3. Make sure that there is no load on the platform.

4. Make sure that the both (base and PCU) emergency switches are in the ON position.
5. Press the lift and travel button together on the PCU while switching ON the key to the platform control position.
6. The PCU display will display 'Menu'.
7. Select 'OPR settings' and press enter.
8. Move the platform raise/lower toggle switch to select 'Rapid cal' function.
9. Press the enter button.
10. Scroll down and select 'Rapid cal', and press enter.
11. Select ON by pressing the left/right button for the angle sensor calibration and press enter.
12. Wait for the green light to blink once.
  - 12.1. Scroll up to enable and change the status to ON, and press enter.
13. Wait for the green light to blink.
  - 13.1. The calibration will start automatically and platform will move up to some height and down once.
14. Once the calibration is complete, base display will show 'RC OK'. Perform a key cycle to save the calibration.
15. If the calibration result shows 'RC NOK' error, do the steps that follow:
  - 15.1. Check the error code.
  - 15.2. Inspect the condition of the corresponding sensors to ensure correct operation.
  - 15.3. Perform the calibration process again.

## 27 - Lifting the Machine

### 00 - General

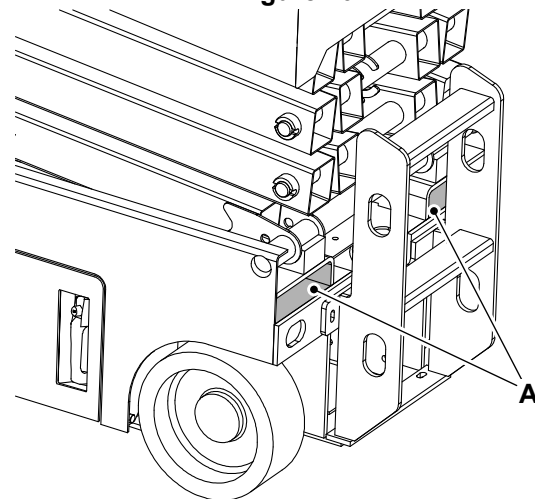
#### Introduction

##### Lifting by Forklift

▲ **Notice:** Do not lift the machine from the side. Lifting the machine from the side will cause damage to the pothole protection system.

1. Make the machine safe with the platform lowered.  
[Refer to: PIL 01-03-27.](#)
2. Check the extension platform, controller and chassis parts are correctly secured.
3. Remove any loose items from the machine.
4. Keep the machine in the lowered position while lifting with the forklift.
5. Use the forklift slots / fork pockets at the ladder side at the end of the machine.
  - 5.1. Align the forks with the forklift slots / fork pockets at the end of the machine.
  - 5.2. Drive the forklift forwards until the forks carriage almost touches the ladder
  - 5.3. When lifting the machine tilt the forks back slightly to ensure the machine will not slide off the forks. Travel with the machine at the specified distance from the ground.  
Length/Dimension/Distance: 0.4m
  - 5.4. Level the forks before landing the machine.

Figure 40.

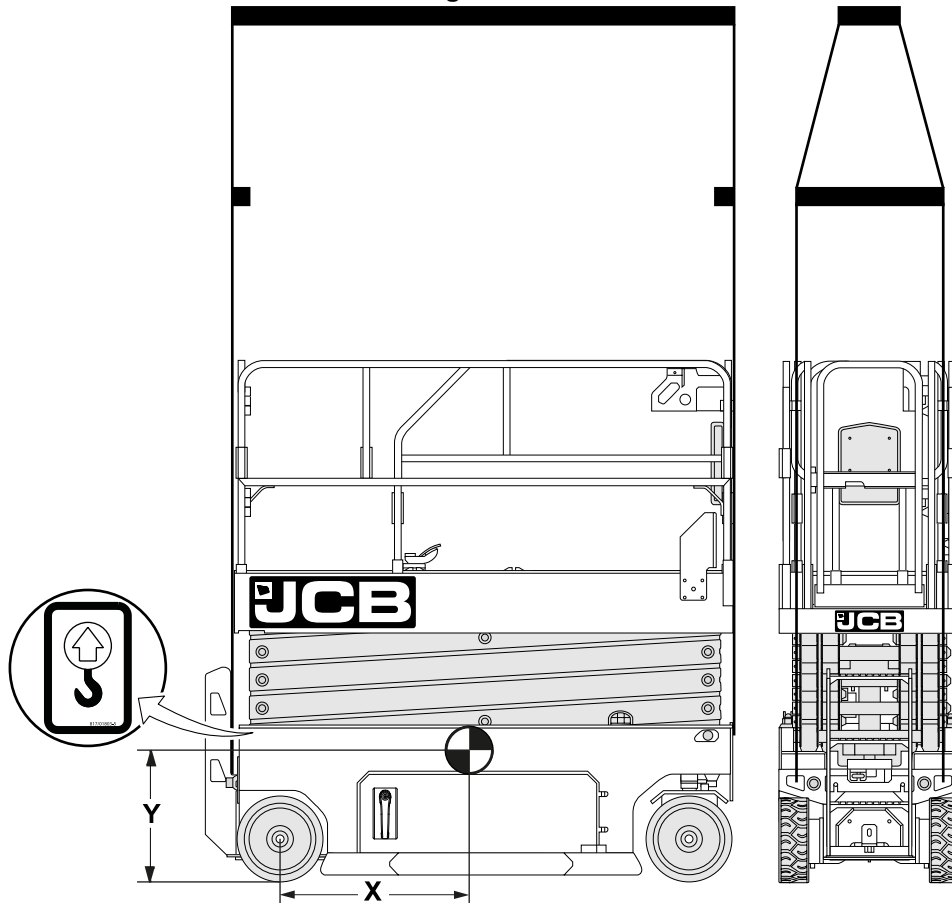


A Forklift slots / fork pockets

##### Lifting by Hoist

1. Make the machine safe with the platform lowered.  
[Refer to: PIL 01-03-27.](#)
2. Check the extension platform, controller and chassis parts are correctly secured.
3. Remove any loose items from the machine.
4. Use the correct length of hoisting rope to prevent damage to the platform base and guardrail.
5. Make sure the hoist rigging is in the correct position. Adjust the hoist rigging to prevent machine damage and keep the machine in the level position.

Figure 41.



X X axis distance

Y Y axis distance

5.1. You must consider the location of the centre of gravity on the machine, when you lift the machine. Refer to Table 18.

Table 18. Location of the Centre of Gravity

Machine Model	X axis	Y axis
S1932 EDRV	582mm	515mm
S2632 EDRV	927mm	664mm
S2646 EDRV	808mm	610mm
S3246 EDRV	841mm	689mm
S4046 EDRV	842mm	720mm
S4550 EDRV	1,070mm	780mm

## 33 - Cleaning

### 00 - General

Introduction .....	01-60
Preparation .....	01-61

### Introduction

**▲ WARNING** When using cleaning agents, solvents or other chemicals, you must adhere to the manufacturer's instructions and safety precautions.

**CAUTION** To avoid burning, wear personal protective equipment when handling hot components. To protect your eyes, wear goggles when using a brush to clean components.

**Notice:** Cleaning metal parts with incorrect solvents can cause corrosion. Use only recommended cleaning agents and solvents.

**Notice:** The efficiency of the rams will be affected if they are not kept free of solidified dirt. Clean dirt from around the rams regularly. When leaving or parking the machine, close all rams if possible to reduce the risk of weather corrosion.

**Notice:** Never use water or steam to clean inside the battery compartment. The use of water or steam could damage the machine electrics and render the machine inoperable. Remove dirt using a brush or damp cloth.

Clean the product with water and/or steam. Do not let mud, debris etc. to collect on the product.

Before you do any service procedures that require components to be removed:

- The cleaning must be done in the area of components to be removed, or in the case of major work, the surrounding product must be cleaned.
- When cleaning is complete, move the product away from the wash area or alternatively, remove the material washed from the product.

When you remove components, be aware of exposure to dirt and debris. Cover any open ports and remove the deposits before proceeding.

### Detergents

Do not use a full strength detergent. Always dilute the detergents as per the manufacturer's recommendations, or damage to the paint finish can occur.

Always obey the local regulations regarding the disposal of debris created from cleaning the product.

## Pressure Washing and Steam Cleaning

**▲ CAUTION** When using a steam cleaner, wear safety glasses or a face shield as well as protective clothing. Steam can cause personal injury.

The electrical components could be damaged by high pressure washing systems. Special precautions must be taken if the machine is to be washed using a high pressure system. Make sure that the electrical components are shielded and not directly cleaned by the high pressure cleaning system. Do not aim the water jet directly at internal surface of the machine.

Use a low pressure water jet and brush to remove dried mud or dirt.

Use a pressure washer to remove soft dirt and oil.

The product must always be greased (if appropriate) after pressure washing or steam cleaning.

**Table 19. Pressure Washing**

Nozzle size	Distance	Water flow rate
6mm	2.5–3m	12.5L/min not exceeding 3

## Preparation

1. Make the machine safe. Stop the machine and let it cool for at least one hour. Do not try to clean any part of the machine while it is running.
2. Make sure that all of the electrical connectors are correctly coupled.
3. If the connectors are open, attach the correct caps or seal with waterproof tape.

## 48 - Specifications

### 09 - Static Dimensions

#### Technical Data

- For: S1932E EDRV [RAJ] ..... Page 01-62
- For: S2632E EDRV [RAJ] ..... Page 01-62
- For: S3246E EDRV [RAJ] ..... Page 01-63
- For: S2646E EDRV [RAJ] ..... Page 01-63
- For: S4046E EDRV [RAJ] ..... Page 01-63
- For: S4550E EDRV [RAJ] ..... Page 01-64

(For: S1932E EDRV [RAJ])

**Table 20.**

Description	Dimension
Maximum platform height	5.71m (18ft-9in)
Maximum working height <sup>(1)</sup>	7.71m (24ft-9in)
Platform size (L x W x H) <sup>(2)</sup>	1.64m (5ft-5in) x 0.77m (2ft-6.5in) x 1.1m (3ft-7in)
Ground clearance	0.04m (1.5in)
Wheelbase	1.33m (4ft 4in)
Extension outreach	0.9m (2ft-11in)
Overall length (stowed)	1.78m (5ft-10in)
Overall width (stowed)	0.82m (2ft-8.3in)
Overall height (stowed, guardrail folded)	1.85m (6ft-1in)
Overall height (stowed, guardrail unfolded) <sup>(3)</sup>	2.12m (6ft-11in)

*(1) Maximum working height adds 2m to the metric platform height, and adds 6ft to the imperial platform height, based on regional norms.*

*(2) For Australia, New Zealand and South-East Asia, platform height will be 1m (3ft-4in).*

*(3) For Australia, New Zealand and South-East Asia, overall height (stowed, guardrail unfolded) will be 2.02m (6ft-7in).*

(For: S2632E EDRV [RAJ])

**Table 21.**

Description	Dimension
Maximum platform height	7.92m (26ft)
Maximum working height <sup>(1)</sup>	9.92m (32ft)
Platform size (L x W x H)	2.25m (7ft-5in) x 0.83m (2ft-8.5in) x 1.1m (3ft-7in)
Ground clearance	0.06m (2.3in)
Wheelbase	1.85m (6ft)
Extension outreach	0.9m (2ft-11in)
Overall length (stowed)	2.39m (7ft-10in)
Overall width	0.83m (2ft-8.5in)

Description	Dimension
Overall height (stowed, guardrail folded)	1.96m (6ft-5in)
Overall height (stowed, guardrail unfolded)	2.33m (7ft-8in)

(1) Maximum working height adds 2m to the metric platform height, and adds 6ft to the imperial platform height, based on regional norms

(For: S3246E EDRV [RAJ])

**Table 22.**

Description	Dimension
Maximum platform height	9.68m (31ft-9in)
Maximum working height <sup>(1)</sup>	11.68m (37ft-9in)
Platform size (L x W x H)	2.25m (7ft-5in) x 1.17m (3ft-10in) x 1.1m (3ft-7in)
Ground clearance	0.1m (3in)
Wheelbase	1.85m (6ft-1in)
Extension outreach	0.9m (2ft-11in)
Overall length (stowed)	2.39m (7ft-10in)
Overall width (stowed)	1.18m (3ft-10.5in)
Overall height (stowed, guardrail folded)	1.86m (6ft-1in)
Overall height (stowed, guardrail unfolded)	2.48m (8ft-2in)

(1) Maximum working height adds 2m to the metric platform height, and adds 6ft to the imperial platform height, based on regional norms.

(For: S2646E EDRV [RAJ])

**Table 23.**

Description	Dimension
Maximum platform height	7.90m (25.9ft)
Maximum working height <sup>(1)</sup>	9.9m (32.4ft)
Platform size (L x W x H)	2.25m (7ft-5in) x 1.15m (3ft-9in) x 1.1m (3ft-7in)
Ground clearance	0.1m (4in)
Wheelbase	1.85m (6ft-1in)
Extension outreach	0.95m (3ft-1in)
Overall length (stowed)	2.39m (7ft-10in)
Overall width	1.18m (3ft-10.5in)
Overall height (stowed, guardrail folded)	1.73m (5ft-9in)
Overall height (stowed, guardrail unfolded)	2.35m (7ft-8in)

(1) Maximum working height adds 2m to the metric platform height, and adds 6ft to the imperial platform height, based on regional norms.

(For: S4046E EDRV [RAJ])

**Table 24.**

Description	Dimension
Maximum platform height	11.9m (40ft)
Maximum working height <sup>(1)</sup>	13.9m (45ft)
Platform size (L x W x H)	2.25m (7ft-5in) x 1.15m (3ft-9in) x 1.1m (3ft-7in)
Ground clearance	0.1m (4in)
Wheelbase	1.85m (6ft)
Extension outreach	0.9m (3ft)
Overall length (stowed)	2.39m (7ft-10in)



Description	Dimension
Overall width	1.18m (3ft-10.5in)
Overall height (stowed, guardrail folded)	1.98m (6ft-6in)
Overall height (stowed, guardrail unfolded)	2.6m (8ft-6in)

*(1) Maximum working height adds 2m to the metric platform height, and adds 6ft to the imperial platform height, based on regional norms.*

(For: S4550E EDRV [RAJ])

**Table 25.**

Description	Dimension
Maximum platform height	13.8m (45.3ft)
Maximum working height <sup>(1)</sup>	15.8m (51ft-3in)
Platform size (L x W x H)	2.64m (8ft-8in) x 1.15m (3ft-9in) x 1.1m (3ft-7in)
Ground clearance	0.1m (4in)
Wheelbase	2.22m (87in)
Extension outreach	0.9m (35in)
Overall length (stowed)	2.76m (9ft-1in)
Overall width (stowed)	1.27m (4.16ft)
Overall height (stowed, guardrail folded)	2.2m (7ft-3in)
Overall height (stowed, guardrail unfolded)	2.6m (8ft-6in)

*(1) Maximum working height adds 2m to the metric platform height, and adds 6ft to the imperial platform height, based on regional norms.*

## 10 - Weights

### Technical Data

- For: S1932E EDRV [RAJ] ..... Page 01-65
- For: S2632E EDRV [RAJ] ..... Page 01-65
- For: S3246E EDRV [RAJ] ..... Page 01-66
- For: S2646E EDRV [RAJ] ..... Page 01-66
- For: S4046E EDRV [RAJ] ..... Page 01-66
- For: S4550E EDRV [RAJ] ..... Page 01-67

(For: S1932E EDRV [RAJ])

**Table 26.**

Description	Dimension
Overall weight	1,590kg
Load capacity	230kg
Maximum platform occupants (indoor)	2 persons
Maximum platform occupants (outdoor)	1 person
Maximum allowable side force (indoor)	400N
Maximum allowable side force (outdoor)	200N
Maximum wheel loads <sup>(1, 2)</sup>	603kg
Ground pressure per tyre <sup>(1, 2)</sup>	1135kN/m <sup>2</sup>

(1) This assumes the typical wheel surface area in contact with the ground is approximately 15% wheel diameter x wheel width.

(2) Wheel loads and pressures are approximate and only cover standard manufacturer wheel configurations. These figures should only be used with adequate safety factors.

(For: S2632E EDRV [RAJ])

**Table 27.**

Description	Dimension
Overall weight	2,180kg
Load capacity <sup>(3)</sup>	250kg
Extension desk maximum load capacity	120kg
Maximum platform occupants (indoor)	2 persons
Maximum platform occupants (outdoor)	N/A
Maximum allowable side force (indoor)	400N
Maximum allowable side force (outdoor)	N/A
Maximum wheel loads <sup>(1, 2)</sup>	1,135kg
Localized pressure per tyre <sup>(1, 2)</sup>	1469 kN/m <sup>2</sup>

(1) This assumes the typical wheel surface area in contact with the ground is approximately 15% wheel diameter x wheel width.

(2) Wheel loads and pressures are approximate and only cover standard manufacturer wheel configurations. These figures should only be used with adequate safety factors.

(3) Mass of all additional accessories must be considered as part of platform load capacity for use and load calibration.

(For: S3246E EDRV [RAJ])

**Table 28.**

Description	Dimension
Overall weight	2,865kg
Load capacity	320kg
Maximum platform occupants (indoor)	2 persons
Maximum platform occupants (outdoor)	1 person
Maximum allowable side force (indoor)	400N
Maximum allowable side force (outdoor)	200N
Maximum wheel loads <sup>(1, 2)</sup>	1,268kg
Localized pressure per tyre <sup>(1, 2)</sup>	1632 kN/m <sup>2</sup>

(1) This assumes the typical wheel surface area in contact with the ground is approximately 15% wheel diameter x wheel width.

(2) Wheel loads and pressures are approximate and only cover standard manufacturer wheel configurations. These figures should only be used with adequate safety factors.

(For: S2646E EDRV [RAJ])

**Table 29.**

Description	Dimension
Overall weight	2,647kg
Load capacity	450kg
Extension desk maximum load capacity	120kg
Maximum platform occupants (indoor)	2 persons
Maximum platform occupants (outdoor)	2 persons
Maximum allowable side force (indoor)	400N
Maximum allowable side force (outdoor)	400N
Maximum wheel loads <sup>(1, 2)</sup>	1,453kg
Localized pressure per tyre <sup>(1, 2)</sup>	1880kN/m <sup>2</sup>

(1) This assumes the typical wheel surface area in contact with the ground is approximately 15% wheel diameter x wheel width.

(2) Wheel loads and pressures are approximate and only cover standard manufacturer wheel configurations. These figures should only be used with adequate safety factors.

(For: S4046E EDRV [RAJ])

**Table 30.**

Description	Dimension
Overall weight	3,060kg
Load capacity	320kg
Extension desk maximum load capacity	120kg
Maximum platform occupants (indoor)	2 persons
Maximum platform occupants (outdoor)	N/A
Maximum allowable side force (indoor)	400N
Maximum allowable side force (outdoor)	N/A



Description	Dimension
Maximum wheel loads <sup>(1, 2)</sup>	1,206kg
Localized pressure per tyre <sup>(1, 2)</sup>	1561 kN/m <sup>2</sup>

(1) This assumes the typical wheel surface area in contact with the ground is approximately 15% wheel diameter x wheel width.

(2) Wheel loads and pressures are approximate and only cover standard manufacturer wheel configurations. These figures should only be used with adequate safety factors.

(For: S4550E EDRV [RAJ])

**Table 31.**

Description	Dimension
Overall weight	3,538kg
Load capacity	230kg
Extension desk maximum load capacity	120kg
Maximum platform occupants (indoor)	2 persons
Maximum platform occupants (outdoor)	N/A
Maximum allowable side force (indoor)	400N
Maximum allowable side force (outdoor)	N/A
Maximum wheel loads <sup>(1, 2)</sup>	1,212kg
Localized pressure per tyre <sup>(1, 2)</sup>	15.73bar (228.1psi)

(1) This assumes the typical wheel surface area in contact with the ground is approximately 15% wheel diameter x wheel width.

(2) Wheel loads and pressures are approximate and only cover standard manufacturer wheel configurations. These figures should only be used with adequate safety factors.

## 12 - Lift Arm Dimensions and Performance

### Technical Data

For: S1932E EDRV [RAJ] ..... Page 01-68  
 For: S2632E EDRV [RAJ] ..... Page 01-68  
 For: S3246E EDRV [RAJ] ..... Page 01-69  
 For: S2646E EDRV [RAJ] ..... Page 01-69  
 For: S4046E EDRV [RAJ] ..... Page 01-70  
 For: S4550E EDRV [RAJ] ..... Page 01-70

(For: S1932E EDRV [RAJ])

**Table 32.**

Description	Dimension
Maximum allowable wind speed (outdoor)	12.5m/s (1 person only)
Maximum allowable slope (front/back) <sup>(1)</sup>	3°
Maximum allowable slope (side/side) <sup>(1)</sup>	1.5°
Turning radius (outside)	1.54m (5ft-1in)
Turning radius (inside)	0.06m (2.4in)
Gradeability <sup>(2, 3, 4)</sup>	25%
Elevated driving speed/time over 10m <sup>(1)</sup>	0.8km/h (0.5mph)/42–49s
Hare speed/time over 10m <sup>(2)</sup>	4km/h (2.5mph)/10–12s
Tortoise speed/time over 10m <sup>(2)</sup>	1.8km/h (1.1mph)/19–23s
Rising speed (full load)	20–25s
Lowering speed (full load)	25–30s
Rising speed (no load)	15–20s
Lowering speed (no load)	30–35s
Drive, steer and brake	2, front-wheel
Brake distance (level ground)	0.4 ± 0.1m

(1) Platform in raised condition.

(2) Platform in stowed condition.

(3) Gradeability is subject to ground conditions with one person in the platform and adequate traction. Additional platform weight may reduce gradeability.

(4) Limit the travel speed to tortoise mode while coming down a slope/grade.

(For: S2632E EDRV [RAJ])

**Table 33.**

Description	Dimension
Maximum allowable wind speed (outdoor)	0m/s (Indoor only)
Maximum allowable slope (front/back) <sup>(1)</sup>	3°
Maximum allowable slope (side/side) <sup>(1)</sup>	1.5°
Turning radius (outside)	2.1m (6ft-10.68in)
Turning radius (inside)	0m (0ft-0in)
Gradeability <sup>(2, 3, 4)</sup>	25%
Elevated driving speed/time over 10m <sup>(1)</sup>	0.8km/h (0.5mph)/45–49s
Hare speed/time over 10m <sup>(2)</sup>	4.5km/h (2.8mph)/10–14s
Tortoise speed/time over 10m <sup>(2)</sup>	1.8km/h (1.1mph)/19–23s



Description	Dimension
Rising speed (full load)	28–34s
Lowering speed (full load)	32–38s
Rising speed (no load)	25–31s
Lowering speed (no load)	38–44s
Drive, steer and brake	2, front-wheel
Brake distance (level ground)	0.8 ± 0.1m

(1) Platform in raised condition.

(2) Platform in stowed condition.

(3) Gradeability is subject to ground conditions with one person in the platform and adequate traction. Additional platform weight may reduce gradeability.

(4) Limit the travel speed to tortoise mode while coming down a slope/grade.

(For: S3246E EDRV [RAJ])

**Table 34.**

Description	Dimension
Maximum allowable wind speed (outdoor)	12.5m/s (1 person only)
Maximum allowable slope (front/back) <sup>(1)</sup>	3°
Maximum allowable slope (side/side) <sup>(1)</sup>	1.5°
Turning radius (outside)	2.35m (7ft-8.5in)
Turning radius (inside)	0m (0ft-0in)
Gradeability <sup>(2, 3, 4)</sup>	25%
Elevated driving speed/time over 10m <sup>(1)</sup>	0.8km/h (0.5mph)/45–49s
Hare speed/time over 10m <sup>(2)</sup>	4.5km/h (2.8mph)/10–14s
Tortoise speed/time over 10m <sup>(2)</sup>	1.8km/h (1.1mph)/19–23s
Rising speed (full load)	49–54s
Lowering speed (full load)	40–46s
Rising speed (no load)	44–50s
Lowering speed (no load)	47–53s
Drive, steer and brake	2, front-wheel
Brake distance (level ground)	0.8 ± 0.1m

(1) Platform in raised condition.

(2) Platform in stowed condition.

(3) Gradeability is subject to ground conditions with one person in the platform and adequate traction. Additional platform weight may reduce gradeability.

(4) Limit the travel speed to tortoise mode while coming down a slope/grade.

(For: S2646E EDRV [RAJ])

**Table 35.**

Description	Dimension
Maximum allowable wind speed (outdoor)	12.5m/s
Maximum allowable slope (front/back) <sup>(1)</sup>	3°
Maximum allowable slope (side/side) <sup>(1)</sup>	1.5°
Turning radius (outside)	2.35m (7ft-8in)
Turning radius (inside)	0m (0ft-0in)
Gradeability <sup>(2, 3, 4)</sup>	25%
Elevated driving speed/time over 10m	0.8km/h (0.5mph)/45–49s
Hare speed/time over 10m	4.5km/h (2.8mph)/7–9s
Tortoise speed/time over 10m	2.2km/h (1.4mph)/14–17s



Description	Dimension
Raising speed (full load)	43–49s
Lowering speed (full load)	30–36s
Rising speed (no load)	34–40s
Lowering speed (no load)	42–48s
Drive, steer and brake	2, front-wheel
Brake distance (level ground)	0.76 ± 0.1m

(1) Platform in raised condition.

(2) Platform in stowed condition.

(3) Gradeability is subject to ground conditions with one person in the platform and adequate traction. Additional platform weight may reduce gradeability.

(4) Limit the travel speed to tortoise mode while coming down a slope/grade.

(For: S4046E EDRV [RAJ])

**Table 36.**

Description	Dimension
Maximum allowable wind speed (outdoor)	0m/s, Indoor Only
Maximum allowable slope (front/back) <sup>(1)</sup>	3°
Maximum allowable slope (side/side) <sup>(1)</sup>	1.5°
Turning radius (outside)	2.35m (7ft-8in)
Turning radius (inside)	0m (0ft-0in)
Gradeability <sup>(2, 3, 4)</sup>	25%
Elevated driving speed/time over 10m	0.8km/h (0.5mph)/45–49s
Hare speed/time over 10m	4.5km/h (2.8mph)/7–9s
Tortoise speed/time over 10m	2.2km/h (1.4mph)/14–17s
Raising speed (full load)	62–67s
Lowering speed (full load)	46–54s
Rising speed (no load)	57–62s
Lowering speed (no load)	52–60s
Drive, steer and brake	2, front-wheel
Brake distance (level ground)	0.62 ± 0.1m

(1) Platform in raised condition.

(2) Platform in stowed condition.

(3) Gradeability is subject to ground conditions with one person in the platform and adequate traction. Additional platform weight may reduce gradeability.

(4) Limit the travel speed to tortoise mode while coming down a slope/grade.

(For: S4550E EDRV [RAJ])

**Table 37.**

Description	Dimension
Maximum allowable wind speed (outdoor)	0m/s (Indoor only)
Maximum allowable slope (front/back) <sup>(1)</sup>	3°
Maximum allowable slope (side/side) <sup>(1)</sup>	1.5°
Turning radius (outside)	2.56m (8ft-5in)
Turning radius (inside)	0m (0ft-0in)
Gradeability <sup>(2, 3, 4)</sup>	25%
Elevated driving speed/time over 10m	0.8km/h (0.5mph)/45–49s
Hare speed/time over 10m	4.5km/h (2.8mph)/7–9s
Tortoise speed/time over 10m	2.2km/h (1.4mph)/14–17s
Raising speed (full load)	73–83s



<b>Description</b>	<b>Dimension</b>
Lowering speed (full load)	56–66s
Rising speed (no load)	63–73s
Lowering speed (no load)	65–75s
Drive, steer and brake	2, front-wheel
Brake distance (level ground)	0.77 ± 0.1m

(1) Platform in raised condition.

(2) Platform in stowed condition.

(3) Gradeability is subject to ground conditions with one person in the platform and adequate traction. Additional platform weight may reduce gradeability.

(4) Limit the travel speed to tortoise mode while coming down a slope/grade.



Notes:

---



---



---



---



---



---



---



---



---



---



---



---



---



---



---



---



---



---



---



---



## 06 - Body and Framework

Contents	Page No.
Acronyms Glossary .....	06-2
06-00 Body and Framework	
06-00-00 General .....	06-3
06-06 Moveable Panel and Cover	
06-06-00 General .....	06-4
06-06-03 Battery Compartment .....	06-10
06-06-09 Hydraulic Compartment .....	06-11
06-14 Scissor Arm	
06-14-00 General .....	06-12
06-14-60 Slider Block .....	06-23
06-14-81 Bush .....	06-25
06-30 Pivot Pins	
06-30-00 General .....	06-26
06-45 Gas Strut	
06-45-45 Pothole Protection .....	06-28
06-47 Ladder	
06-47-00 General .....	06-29
06-57 Counterweight	
06-57-00 General .....	06-30
06-63 Identification Label	
06-63-00 General .....	06-34
06-63-03 Machine .....	06-35
06-66 Tools	
06-66-00 General .....	06-37
06-93 Emergency Lower System	
06-93-00 General .....	06-38
06-93-03 Cable .....	06-41
06-94 Pothole Protection System	
06-94-00 General .....	06-44
06-94-04 Actuator Rod .....	06-49
06-94-06 Plate .....	06-50
06-97 Platform	
06-97-00 General .....	06-51
06-97-03 Platform Extension .....	06-58
06-97-06 Guardrail .....	06-61
06-97-09 Gate .....	06-65
06-97-12 Gate Hinge .....	06-66
06-97-30 Extension Pedal .....	06-67
06-97-50 Wear Pads .....	06-69



---

## Acronyms Glossary

AC	Alternating Current
PIN	Product Identification Number

## 00 - Body and Framework

### 00 - General

#### Check (Condition)

1. Make sure that all of the guards and protective devices are in position, secured by their locking devices and free from damage.
2. Inspect all of the steelwork for damage. Include the following:
  - 2.1. Examine all of the pivot point welds.
  - 2.2. Examine the condition of all the pivot pins.
  - 2.3. Check that the pivot pins are correctly in position and secured by their locking devices.
3. Check the steps and guardrails are undamaged and correctly attached.
4. Check that all of the safety and instructional labels are undamaged and in position. Install new labels where necessary.
5. Note any damaged paintwork for future repair.
6. Inspect the machine for broken or loose fasteners.
7. Raise the platform until pot hole protection is activated.
8. Check the condition of the pot hole protection bars and the pothole protection decal.



## 06 - Moveable Panel and Cover

### 00 - General

Introduction .....	06-4
Remove and Install .....	06-5

### Introduction

Access panels provide easy access to the machine major components test and service points and other parts which require routine testing, servicing, adjusting, replacement or repair.

Before you operate the machine, make sure that all of the access panels are in their operation position and secure.

JCB © CONNOR STANMORE - 13/03/2026 07:57.

## Remove and Install

For: S1932E EDRV [RAJ] ..... Page 06-5

For: S2632E EDRV [RAJ] ..... Page 06-6

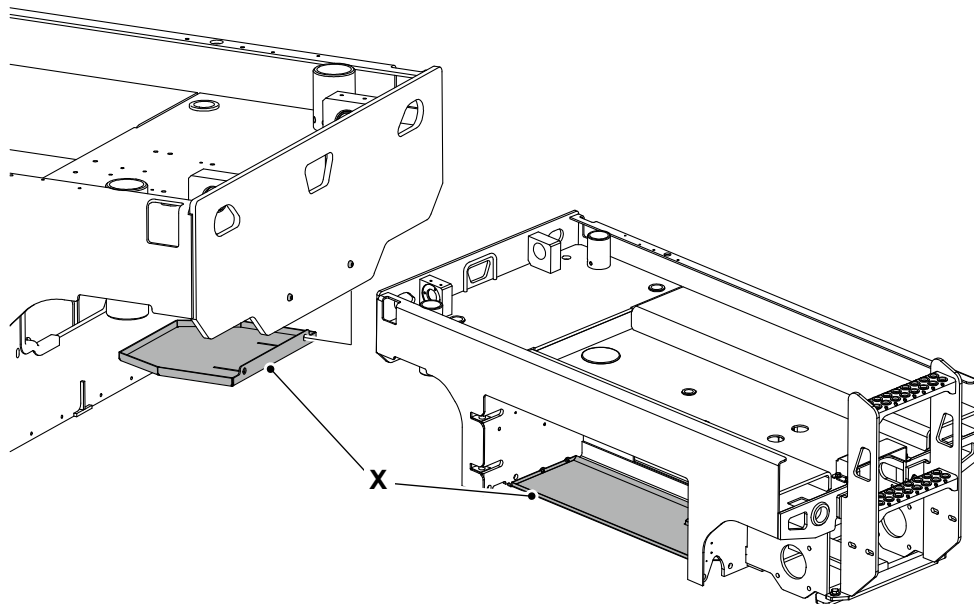
For: S2646E EDRV [RAJ], S3246E EDRV [RAJ], S4046E EDRV [RAJ], S4550E EDRV [RAJ] ..... Page 06-8

(For: S1932E EDRV [RAJ])

The illustration shows the typical spill kit (if fitted). Number of spill trays and its design on your machine may vary.

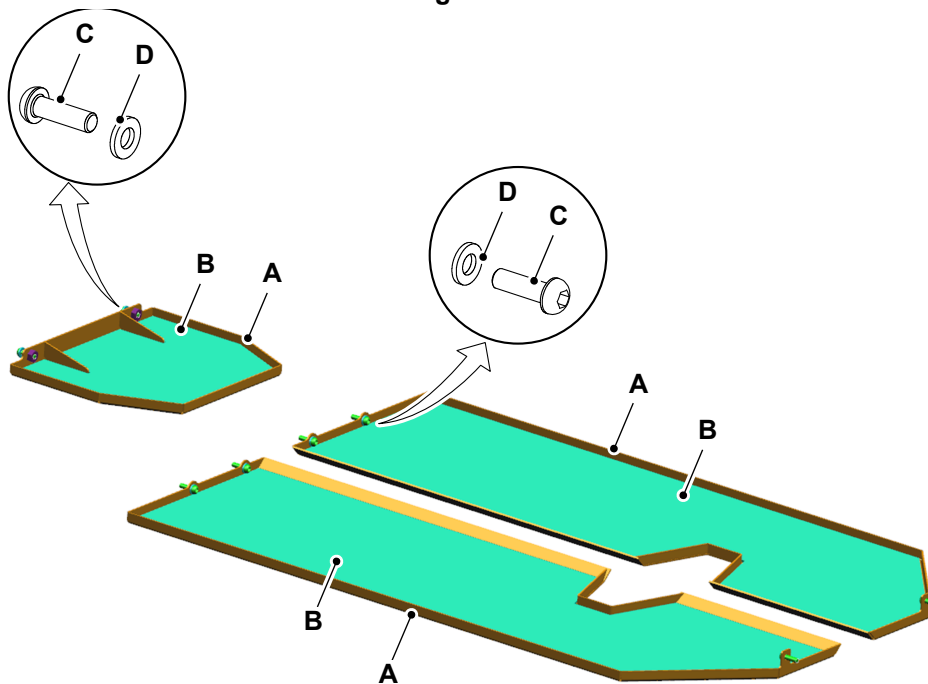
### Spill Kit (If Fitted)

Figure 42.



X Spill kit

Figure 43.



- A** Spill tray (x3)
- C** Capscrew (x8)

- B** Absorbent pad (x3)
- D** Washer (x8)

**Remove**

1. Make the machine safe.  
[Refer to: PIL 01-03-27.](#)
2. Disconnect the battery quick disconnect handle.  
[Refer to: PIL 33-05-00.](#)
3. Get access to the spill kit located at the bottom of the chassis and below the steering cylinder.  
[Refer to Figure 42.](#)
4. Remove the capscrew (x8) and washer (x8) from the spill kit located at the bottom of the chassis and below the steering cylinder (as per the requirement). [Refer to Figure 43.](#)

5. Remove the spill kit.

**Install**

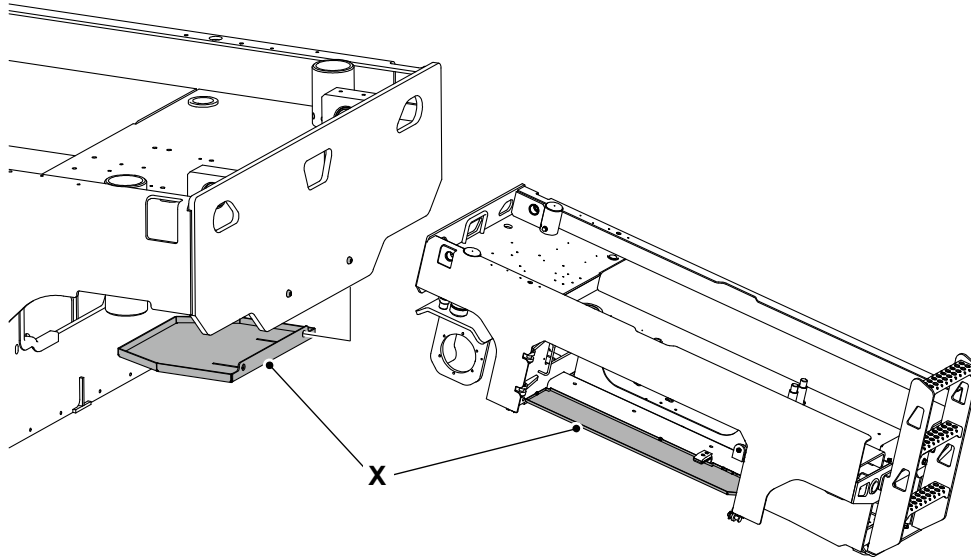
1. The installation procedure is the opposite of the removal procedure. Additionally do the following step.
2. Tighten the fasteners to the correct torque value.  
[Refer to: PIL 72.](#)

(For: S2632E EDRV [RAJ])

The illustration shows the typical spill kit (if fitted). Number of spill trays and its design on your machine may vary.

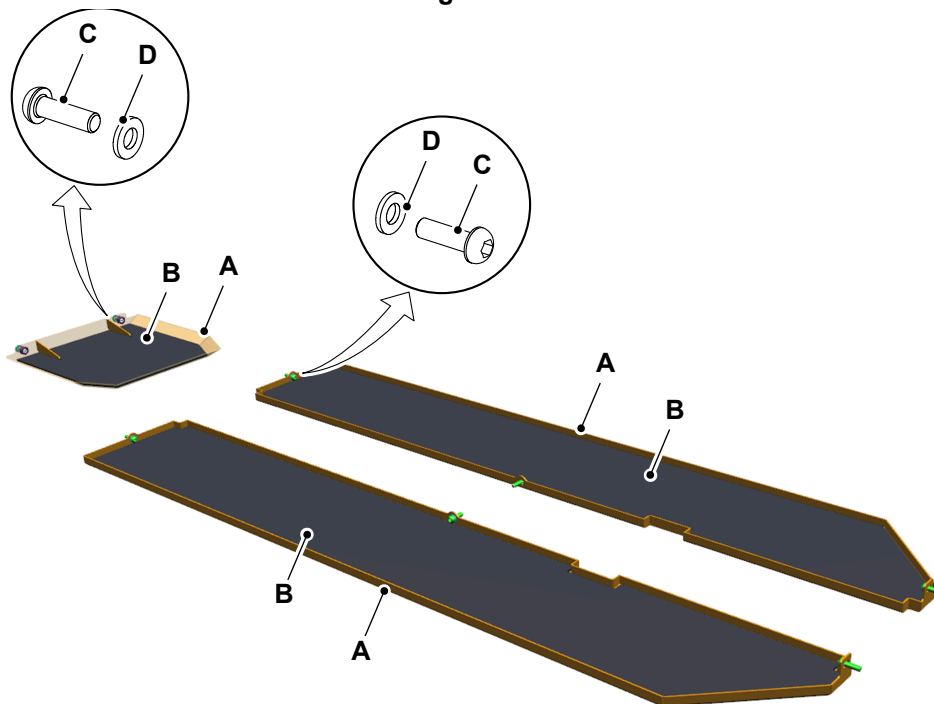
**Spill Kit (If Fitted)**

**Figure 44.**



**X** Spill kit

**Figure 45.**



- A** Spill tray (x3)
- C** Capscrew (x8)

- B** Absorbent pad (x3)
- D** Washer (x8)

**Remove**

1. Make the machine safe.  
[Refer to: PIL 01-03-27.](#)

2. Disconnect the battery quick disconnect handle.  
[Refer to: PIL 33-05-00.](#)

3. Get access to the spill kit located at the bottom of the chassis and below the steering cylinder. Refer to Figure 44.
4. Remove the capscrew (x8) and washer (x8) from the spill kit located at the bottom of the chassis and below the steering cylinder (as per the requirement). Refer to Figure 45.
5. Remove the spill kit.

2. Tighten the fasteners to the correct torque value.  
 Refer to: PIL 72.

(For: S2646E EDRV [RAJ], S3246E EDRV [RAJ], S4046E EDRV [RAJ], S4550E EDRV [RAJ])

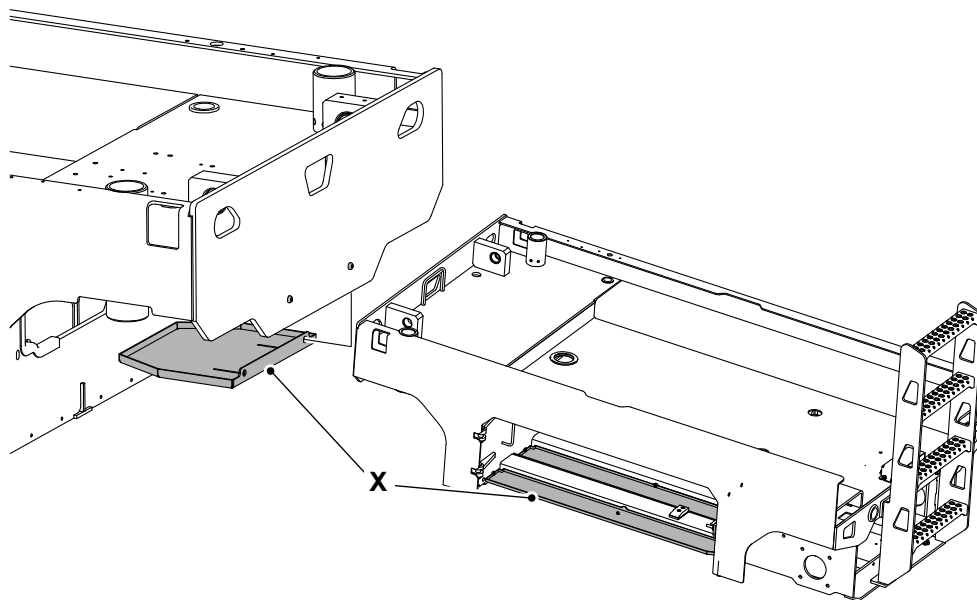
The illustration shows the typical spill kit (if fitted). Number of spill trays and its design on your machine may vary.

**Install**

1. The installation procedure is the opposite of the removal procedure. Additionally do the following step.

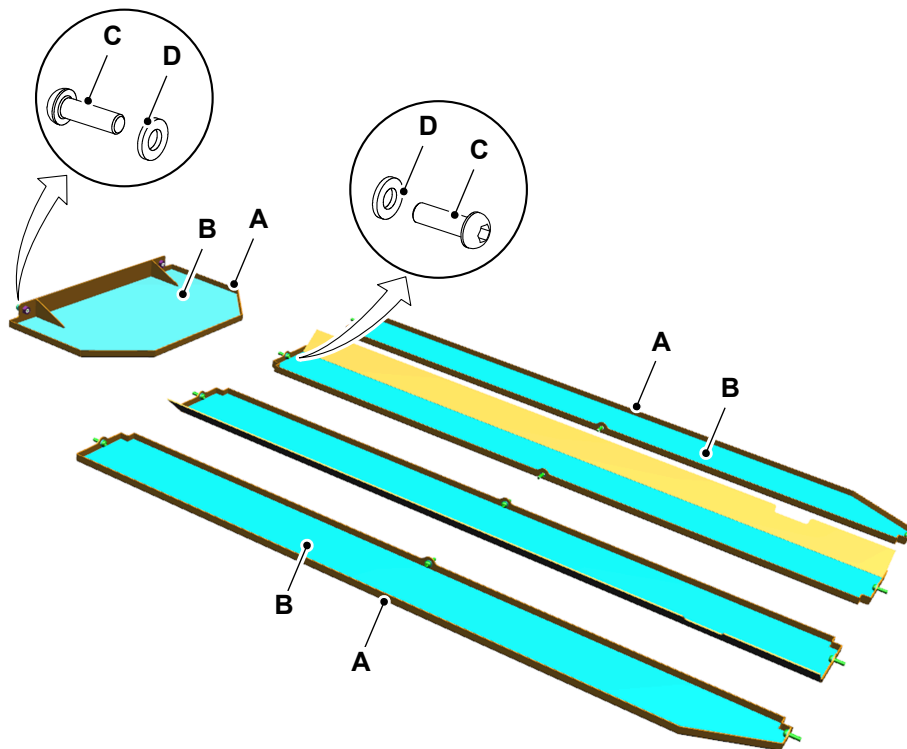
**Spill Kit (If Fitted)**

**Figure 46.**



**X** Spill kit

Figure 47.



- A Spill tray (5)
- C Capscrew (x14)

- B Absorbent pad (5)
- D Washer (x14)

**Remove**

1. Make the machine safe.  
 Refer to: [PIL 01-03-27](#).
2. Disconnect the battery quick disconnect handle.  
 Refer to: [PIL 33-05-00](#).
3. Get access to the spill kit located at the bottom of the chassis and below the steering cylinder.  
 Refer to [Figure 46](#).
4. Remove the capscrew (x14) and washer (x14) from the spill kit located at the bottom of the chassis and below the steering cylinder (as per the requirement). Refer to [Figure 47](#).
5. Remove the spill kit.

**Install**

1. The installation procedure is the opposite of the removal procedure. Additionally do the following step.
2. Tighten the fasteners to the correct torque value.  
 Refer to: [PIL 72](#).

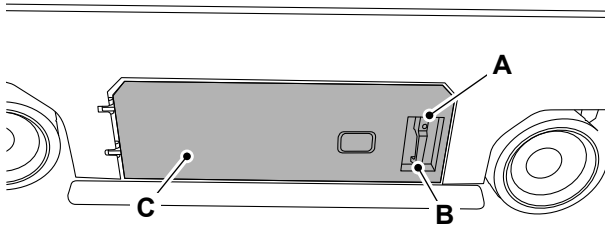
## 03 - Battery Compartment

### Open and Close

#### Open

1. Make the machine safe.
2. Remove the key from the machine.
3. Use the key to unlock the battery compartment door.
4. Press the lock and pull the handle to open the door. [Refer to Figure 48.](#)

**Figure 48.**



- A** Lock
- B** Handle
- C** Battery compartment door

#### Close

1. Close the battery compartment door.
2. Make sure the door is closed correctly.
3. Use the key to lock the door. [Refer to Figure 48.](#)

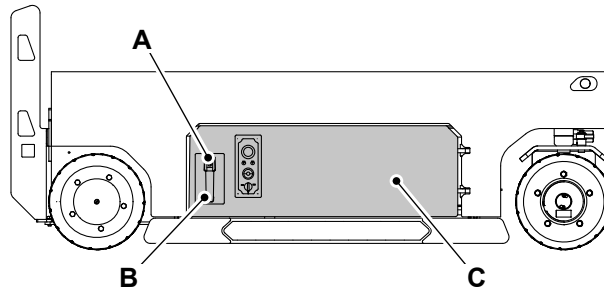
## 09 - Hydraulic Compartment

### Open and Close

#### Open

1. Make the machine safe.
2. Remove the key from the machine.
3. Use the key to unlock the hydraulic compartment door.
4. Press the lock and pull the handle to open the door.

Figure 49.



- A** Lock  
**C** Hydraulic compartment door

**B** Handle

#### Close

1. Close the hydraulic compartment door.
2. Make sure the door is secured correctly.
3. Use the key to lock the door.



## 14 - Scissor Arm

### 00 - General

Introduction .....	06-12
Health and Safety .....	06-13
Component Identification .....	06-14
Operation .....	06-16
Check (Condition) .....	06-18
Remove and Install .....	06-18
Disassemble and Assemble .....	06-20

### Introduction

The scissor lift mechanism is used to move the platform in a vertical direction. The mechanism to achieve this is the use of linked, folding supports in a criss-cross 'X' pattern, known as a scissor mechanism.

The upward motion is achieved by the application of hydraulic cylinders to propel the work platform.

JCB © CONNOR STANMORE - 13/03/2026 07:57.

## Health and Safety

### **Raised Machine**

Never position yourself or any part of your body inside the raised scissor pack which is not correctly supported. If the machine moves unexpectedly you could become trapped and suffer serious injury or be killed.

**CAUTION!** *The scissor arm is potentially dangerous, when pivoting about their centre they form a scissor point. Make sure that the scissor arm is securely blocked when working in the scissor arm area.*

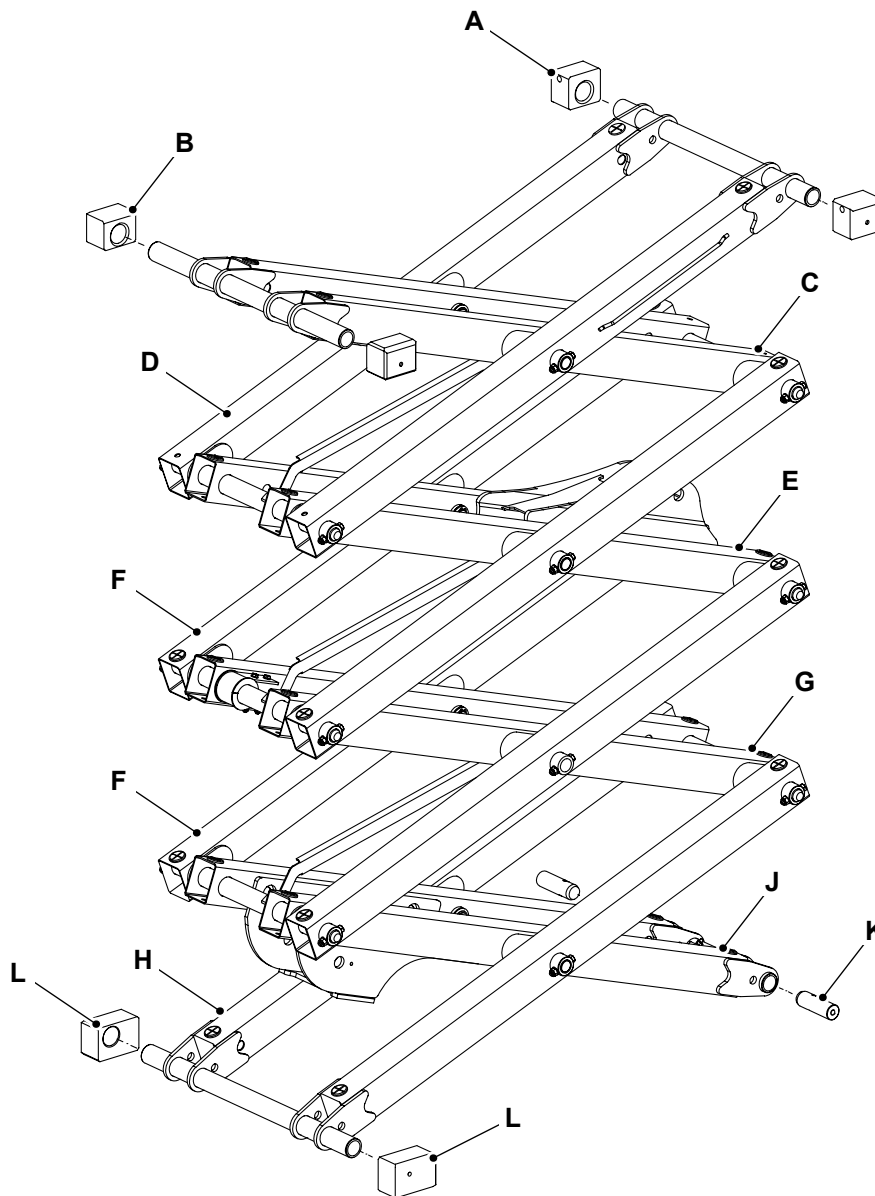
### Component Identification

For: S1932E EDRV [RAJ], S2632E EDRV [RAJ], S2646E EDRV [RAJ] ..... Page 06-14

For: S3246E EDRV [RAJ], S4046E EDRV [RAJ], S4550E EDRV [RAJ] ..... Page 06-15

(For: S1932E EDRV [RAJ], S2632E EDRV [RAJ], S2646E EDRV [RAJ])

Figure 50.



A Top fixed block (x2)

C Inner arm 4 (x2)

E Inner arm 3 (x2)

G Inner arm 2 (x2)

J Inner arm 1 (x2)

B Top slider block (x2)

D Outer arm 4 (x2)

F Outer arm 2 and 3 (x4)

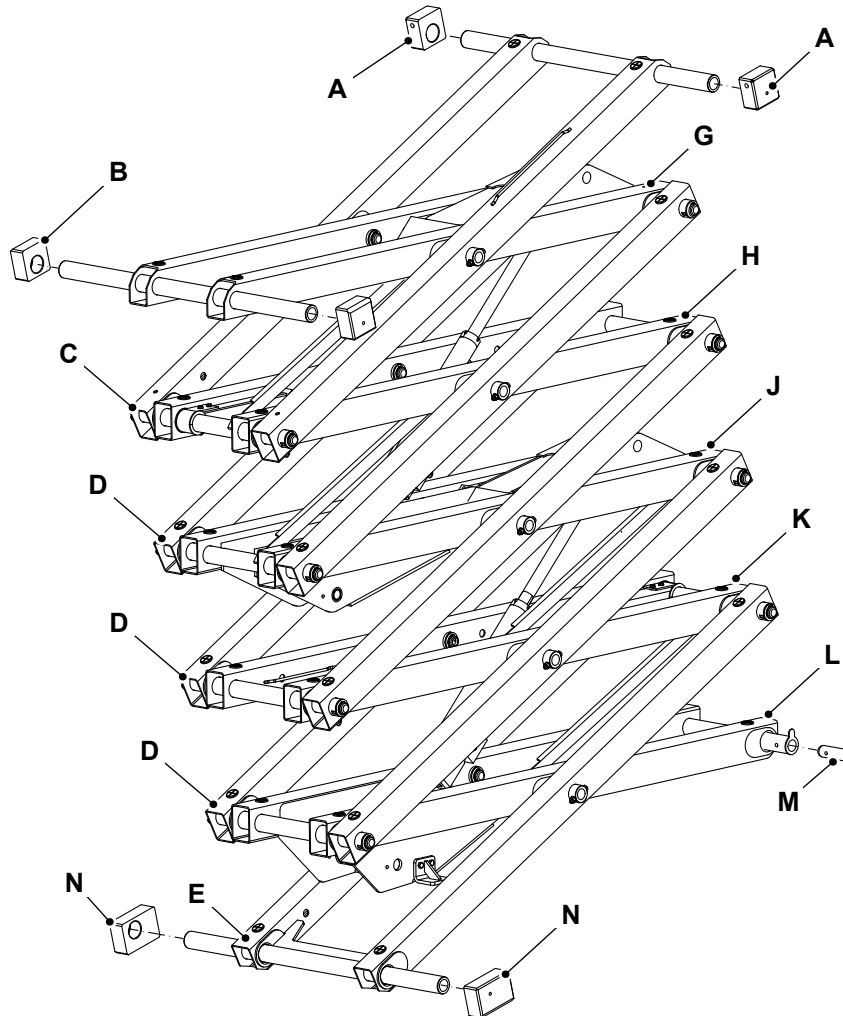
H Outer arm 1(x2)

K Pivot pin (x2)

L Bottom slider block (x2)

(For: S3246E EDRV [RAJ], S4046E EDRV [RAJ], S4550E EDRV [RAJ])

Figure 51.



- A Top fixed block (x2)
- C Outer arm 5 (x2)
- E Outer arm 1 (x2)
- H Inner arm 4 (x2)
- K Inner arm 2 (x2)
- M Pivot pin (x2)
- N Bottom slider block (x2)

- B Top slider block (x2)
- D Outer arm 2,3 and 4 (x6)
- G Inner arm 5 (x2)
- J Inner arm 3 (x2)
- L Inner arm 1 (x2)

## Operation

For: S1932E EDRV [RAJ], S2632E EDRV [RAJ], S2646E EDRV [RAJ] ..... Page 06-16

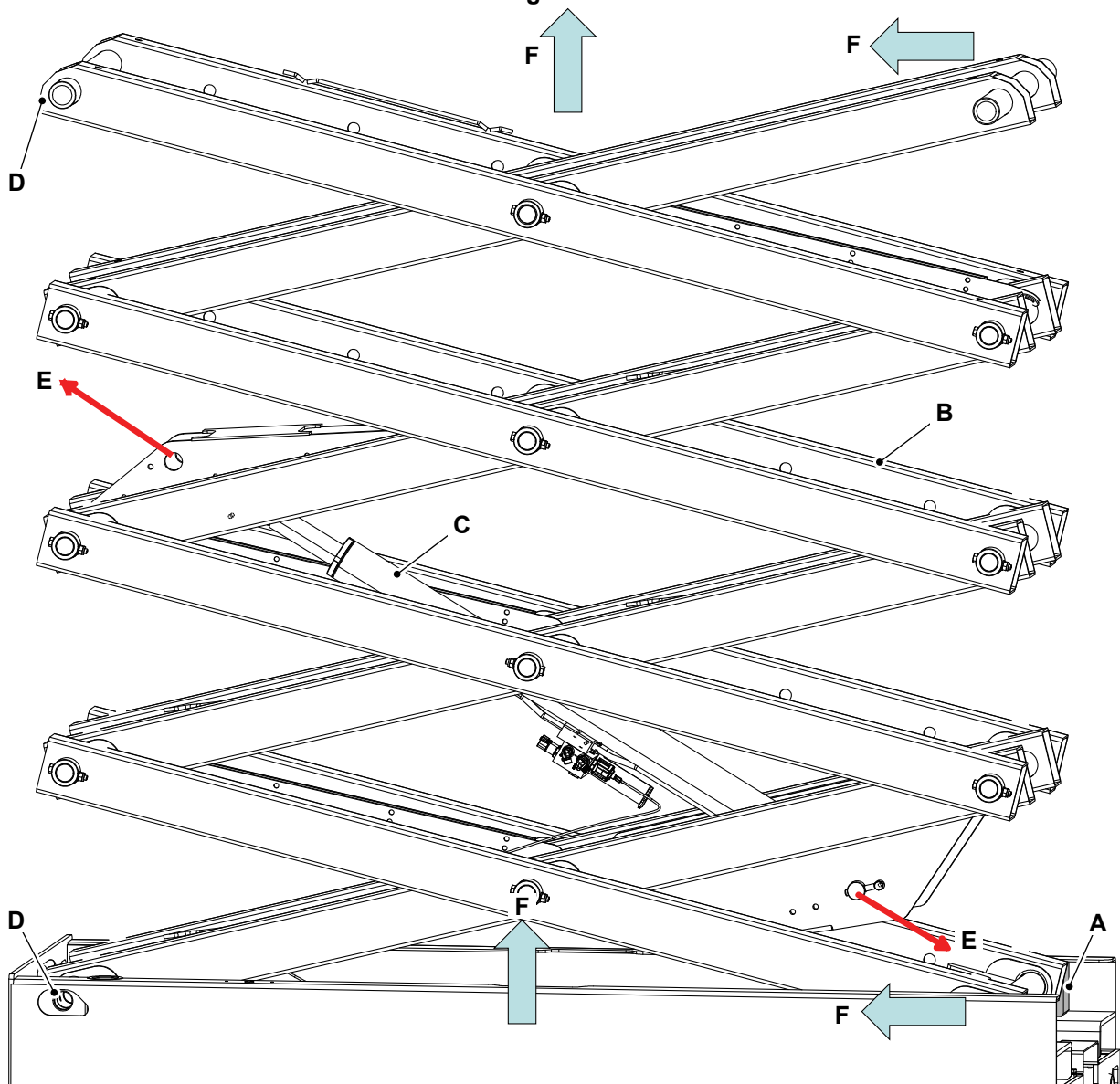
For: S3246E EDRV [RAJ], S4046E EDRV [RAJ], S4550E EDRV [RAJ] ..... Page 06-17

the scissor arms are raised, and the sliding blocks are moved inwards. The platform is raised by the scissors. Refer to Figure 52.

(For: S1932E EDRV [RAJ], S2632E EDRV [RAJ], S2646E EDRV [RAJ])

When the hydraulic pressure is supplied to the cylinder ram, it extends. As the lift cylinder extends,

Figure 52.



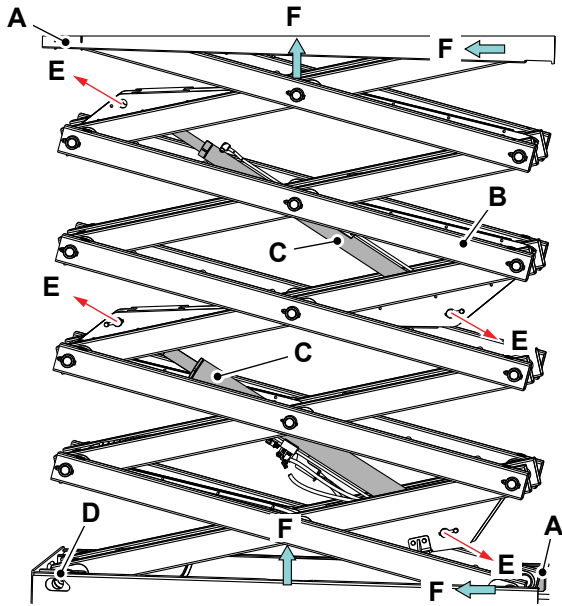
- A Sliding block
- C Cylinder ram
- E Direction of force acting

- B Scissor arm
- D Fixed pivot
- F Direction of movement

(For: S3246E EDRV [RAJ], S4046E EDRV [RAJ], S4550E EDRV [RAJ])

When the hydraulic pressure is supplied to the cylinder ram, it extends. As the lift cylinder extends, the scissor arms are raised, and the sliding blocks are moved inwards. The platform is raised by the scissors. Refer to Figure 53.

Figure 53.



- A Sliding block
- B Scissor arm
- C Cylinder ram
- D Fixed pivot
- E Direction of force acting
- F Direction of movement

JCB © CONNOR STANMORE - 13/03/2026 07:57.

## Check (Condition)

1. Make the machine safe with the platform raised.  
[Refer to: PIL 01-03-27.](#)
2. Make sure that the scissor arm assembly is free from cracks, damages and dents.
3. Make sure that all welds on the scissor arm are free from cracks and damage.
4. Make sure that all fasteners are correctly installed.
5. Make sure that all pivot pins are correctly secured.
6. Note any damaged paintwork for future repair.

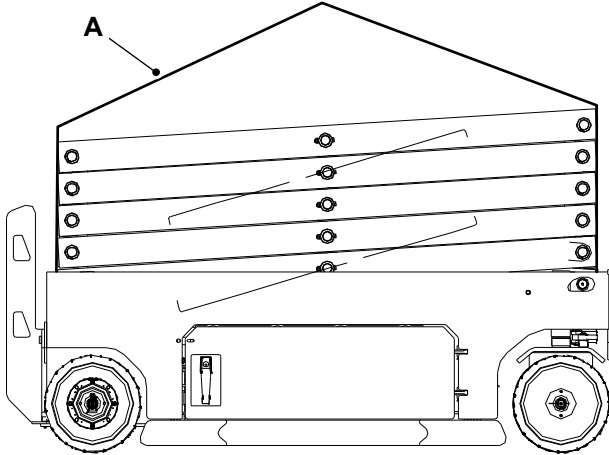
## Remove and Install

**▲ CAUTION** This component is heavy. It must only be removed or handled using a suitable lifting method and device.

### Remove

1. Make the machine safe with the platform lowered.  
[Refer to: PIL 01-03-27.](#)
2. Disconnect the platform control panel from the platform control connection.
3. Plug the platform control panel into the ground control connection.
4. Remove the ladder from the machine.  
[Refer to: Remove and Install \(PIL 06-47-00\).](#)
5. Use the platform control panel to raise the scissor arm.
6. Insert the safety strut.  
[Refer to: PIL 01-03-27.](#)
7. Lower the scissor arm on to the safety strut.
8. Support the scissor arm with suitable lifting equipment. Put suitable wedges under the scissor arm.
9. Put a label on the electrical connectors and hydraulic hoses to help installation.
10. Disconnect the quick disconnect handle.  
[Refer to: Disconnect and Connect \(PIL 33-05-00\).](#)
11. Disconnect all the electrical connectors, remove the scissor arm harness.  
[Refer to: Remove and Install \(PIL 33-95-75\).](#)
12. Disconnect the hydraulic hoses from the scissor arm.
13. Put suitable container underneath the hydraulic connections to collect the hydraulic fluid.
14. Drain the hydraulic oil from the cylinder ram.
  - 14.1. Do not plug the open ports of ram at this stage to allow the extension and retraction of cylinder rams.
15. Remove the platform from the machine.  
[Refer to: Remove and Install \(PIL 06-97-00\).](#)
16. Remove the bolts from the stop pin.

17. Remove the stop pin with a suitable hammer and mandrel.
18. Dismount the scissor arm assembly from the chassis.
19. Remove the scissor arm assembly from the machine.
20. Plug all the open ports and hoses to prevent contamination.

**Figure 54.**

**A** Lifting sling

**Install**

1. The installation procedure is the opposite of the removal procedure.

## Disassemble and Assemble

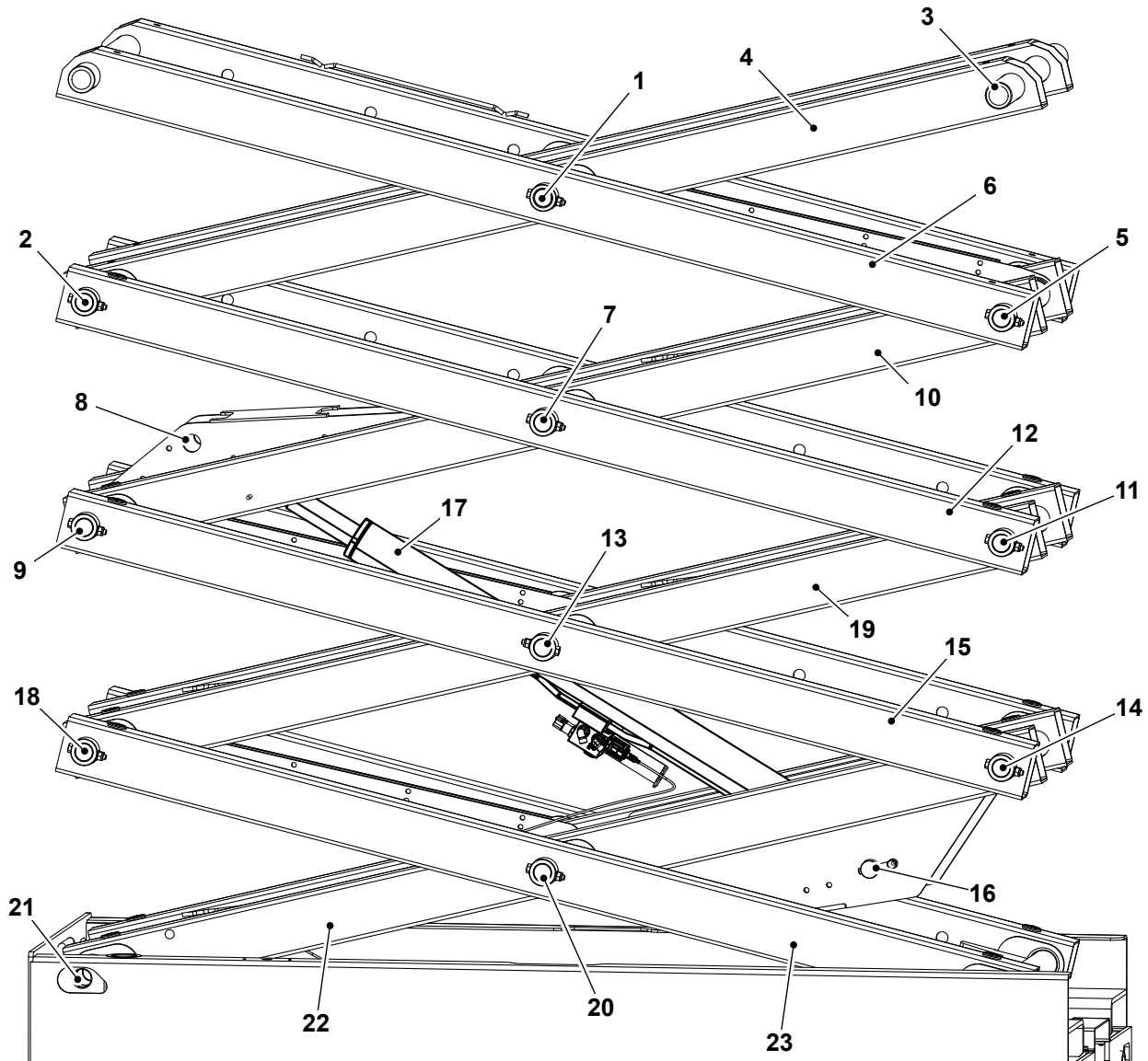
**▲ CAUTION** The scissor arm is potentially dangerous, when pivoting about their centre they form a scissor point. Make sure that the scissor arm is securely blocked when working in the scissor arm area.

### Disassemble

1. Make the machine safe.  
[Refer to: PIL 01-03-27.](#)
2. Remove the platform.

3. Remove the scissor arm assembly.  
[Refer to: Remove and Install \(PIL 06-97-00\).](#)
4. Use the numerical sequence shown on the illustration as a guide to disassembly.
5. Remove the relevant pivot pin.  
[Refer to: Remove and Install \(PIL 06-30-00\).](#)
6. Remove the relevant section of the scissor arm.

Figure 55. Scissor Arm - Single Cylinder

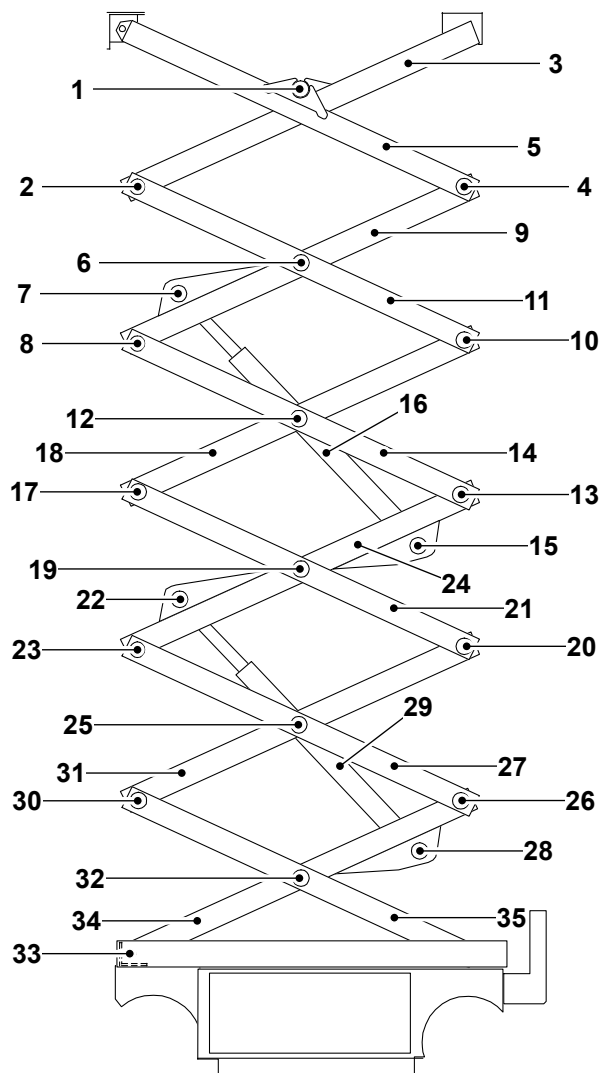


1 Pivot pin 11

2 Pivot pin 9

- |    |                             |    |                                    |
|----|-----------------------------|----|------------------------------------|
| 3  | Pivot pin 12                | 4  | Inner arm 4                        |
| 5  | Pivot pin 10                | 6  | Outer arm 4                        |
| 7  | Pivot pin 8                 | 8  | Lift cylinder rod-end pivot pin    |
| 9  | Pivot pin 6                 | 10 | Inner arm 3                        |
| 11 | Pivot pin 7                 | 12 | Outer arm 3                        |
| 13 | Pivot pin 4                 | 14 | Pivot pin 3                        |
| 15 | Outer arm 2                 | 16 | Lift cylinder barrel-end pivot pin |
| 17 | Lift cylinder               | 18 | Pivot pin 5                        |
| 19 | Inner arm 2                 | 20 | Pivot pin 2                        |
| 21 | Pivot pin 1 (non-steer end) | 22 | Inner arm 1                        |
| 23 | Outer arm 1                 |    |                                    |

**Figure 56. Scissor Arm - Double Cylinder**



- |    |                                       |    |                         |
|----|---------------------------------------|----|-------------------------|
| 1  | Pivot pin 6                           | 2  | Inner pivot pin 5 (x2)  |
| 3  | Upper lift cylinder rod-end pivot pin | 4  | Pivot pin 5 (steer end) |
| 5  | Inner pivot pin 4 (x2)                | 6  | Pivot pin 4 (steer end) |
| 7  | Outer arm 3                           | 8  | Inner pivot pin 3 (x2)  |
| 9  | Lower lift cylinder rod-end pivot pin | 10 | Pivot pin 3 (steer end) |
| 11 | Inner pivot pin 2 (x2)                | 12 | Pivot pin 2 (steer end) |



- |           |                              |           |  |
|-----------|------------------------------|-----------|--|
| <b>13</b> | Inner pivot pin 1 (x2)       | <b>14</b> | Inner arm 1                              |
| <b>15</b> | Pivot pin 1 (steer end) (x2) | <b>16</b> | Inner arm 5                              |
| <b>17</b> | Outer arm 5                  | <b>18</b> | Pivot pin 5 (non-steer end)              |
| <b>19</b> | Inner arm 4                  | <b>20</b> | Outer arm 4                              |
| <b>21</b> | Pivot pin 4 (non-steer end)  | <b>22</b> | Upper lift cylinder barrel-end pivot pin |
| <b>23</b> | Inner arm 3                  | <b>24</b> | Pivot pin 3 (non-steer end)              |
| <b>25</b> | Inner arm 2                  | <b>26</b> | Outer arm 2                              |
| <b>27</b> | Pivot pin 2 (non-steer end)  | <b>28</b> | Lower lift cylinder barrel-end pivot pin |
| <b>29</b> | Outer arm 1                  |           |  |

### Assembly

1. The assembly procedure is the opposite of the disassembly procedure.

## 60 - Slider Block

Check (Condition) ..... 06-23  
 Remove and Install ..... 06-24

## Check (Condition)

### Consumables

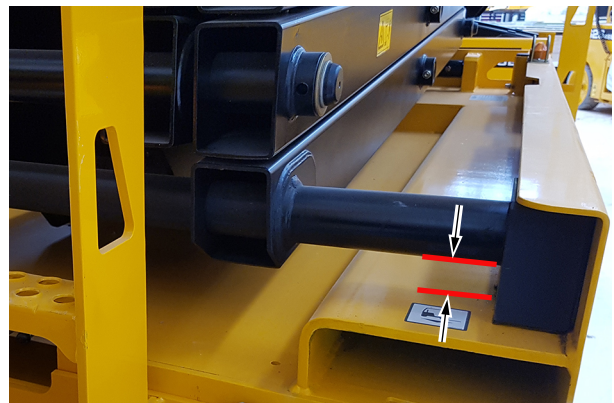
Description	Part No.	Size
Special HP Grease	4003/2020	0.5kg
	4003/2017	0.4kg
	4003/2006	12.5kg
	4003/2005	50kg

1. Make the machine safe with the platform lowered.

Refer to: [Introduction \(PIL 01-03-27\)](#).

2. Check the distance from the shaft to the base of the slider block, for each side of the machine.

**Figure 57.**



3. Check the distance between the fixed end pivot and the bottom mounting plate.

**Figure 58.**



4. Compare the values obtained in step 2 and step 3.
5. If the difference between the values obtained in step 2 and step 3 is more than the specified, replace the slider block.

Dimension: 0.5mm

- Apply specified grease to the scissor sliding area on the chassis and beneath the platform.

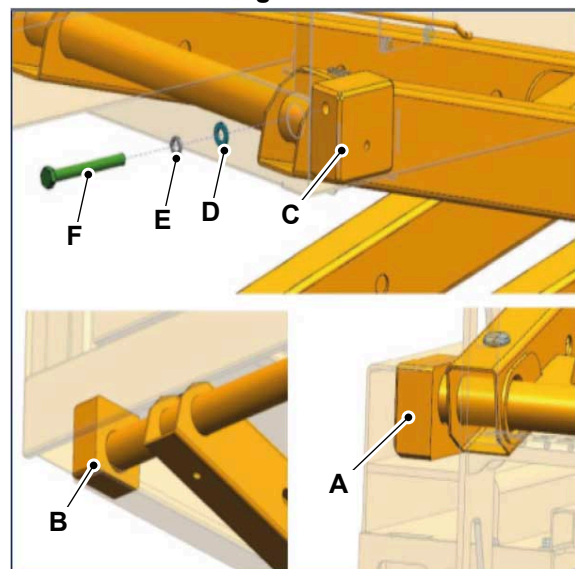
Consumable: Special HP Grease

## Remove and Install

### Remove

- Make the machine safe.  
[Refer to: Introduction \(PIL 01-03-27\).](#)
- Lower the platform to the stowed position.
- Remove the platform.  
[Refer to: Remove and Install \(PIL 06-97-00\).](#)
- Remove the top slider block from the scissor arm.  
[Refer to Figure 59.](#)
- Remove the scissor arm.  
[Refer to: Remove and Install \(PIL 06-14-00\).](#)
- Remove the bottom slider block from the scissor arm.

**Figure 59.**



- A** Bottom slider block (x2)
- B** Top slider block (x2)
- C** Top fixed block (x2)
- D** Plain Washer
- E** Spring Washer
- F** Bolt (x2)

### Install

- The installation procedure is the opposite of the removal procedure.

## 81 - Bush

### Check (Condition)

1. Make the machine safe with the platform lowered.

[Refer to: Introduction \(PIL 01-03-27\).](#)

2. Check the condition of the bush. If damaged, replace it.
3. Check the clearance between the shaft and the bush with a suitable thickness gauge.
4. Make sure that the clearance between the shaft and bush is within the specified limits.

Dimension: 0.1mm



## 30 - Pivot Pins

### 00 - General

Introduction ..... 06-26  
Remove and Install ..... 06-27

### Introduction

The pivot pins are a short shaft or pin that supports something that turns. The pivot pins are installed in numerous positions on the machine.

The ram pivot points installed on these machines are maintenance free and do not required any lubrication.

JCB © CONNOR STANMORE - 13/03/2026 07:57.

## Remove and Install

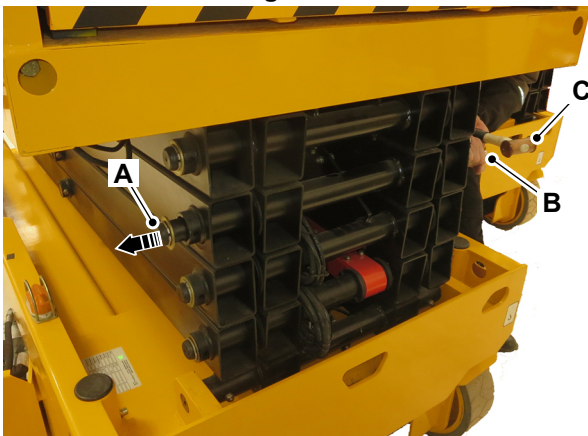
### Remove

The illustration shows a typical pivot pin. The actual pivot pin installed on the machine may look different.

#### Outer Pivot Pin

1. Make the machine safe with the platform lowered.  
[Refer to: Introduction \(PIL 01-03-27\).](#)
2. Prepare the outer pivot pin for removal.
  - 2.1. Remove the outer pivot pin retaining nuts and bolts.
3. Use a suitable hammer and drift to hit the outer pivot pin.
4. Repeat step 3 until the outer pivot pin is released.

**Figure 60.**



- A** Outer pivot pin
- B** Drift
- C** Hammer

#### Inner Pivot Pin

1. Make the machine safe with the platform lowered.  
[Refer to: Introduction \(PIL 01-03-27\).](#)
2. Prepare the inner pivot pin for removal.
3. Use a suitable lifting device to support the scissor arm.
4. Remove the inner pivot pin retaining nuts and bolts.
5. Use a suitable hammer and drift to hit the inner pivot pin.
6. Do the step 5 until the inner pivot pin is released.

**Figure 61.**



- A** Inner pivot pin

### Install

1. The installation procedure is the opposite of the removal procedure.
2. Apply grease to the pivot pins before installation.

## 45 - Gas Strut

### 45 - Pothole Protection

#### Remove and Install

Take care when you remove the gas strut it is under load.

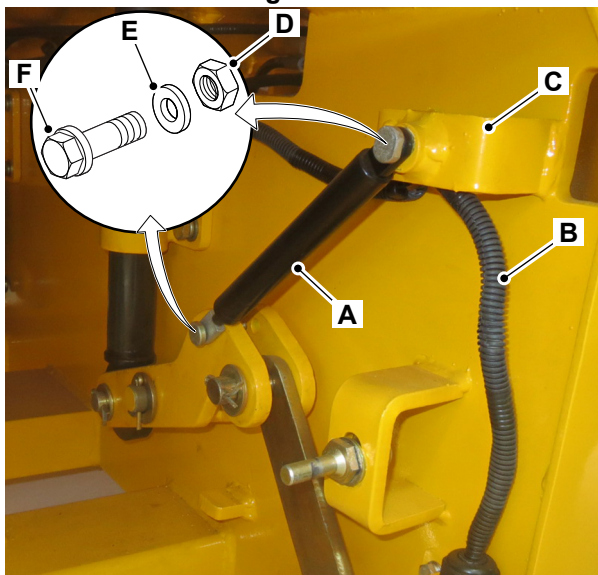
#### Remove

1. Make the machine safe with the platform lowered.  
[Refer to: Introduction \(PIL 01-03-27\).](#)
2. Disconnect the battery quick disconnect handle.  
[Refer to: Disconnect and Connect \(PIL 33-05-00\).](#)
3. Remove the limit switch harness from the bracket.
4. Remove the nut (x2), washer (x2) and bolt (x2).
5. Remove the gas strut.

#### Install

1. The installation procedure is the opposite of the removal procedure.
2. Do not overtighten the nuts.

**Figure 62.**



- A** Gas strut
- B** Limit switch harness
- C** Bracket
- D** Nut
- E** Washer
- F** Bolt

## 47 - Ladder

### 00 - General

#### Remove and Install

For: S1932E EDRV [RAJ] ..... Page 06-29

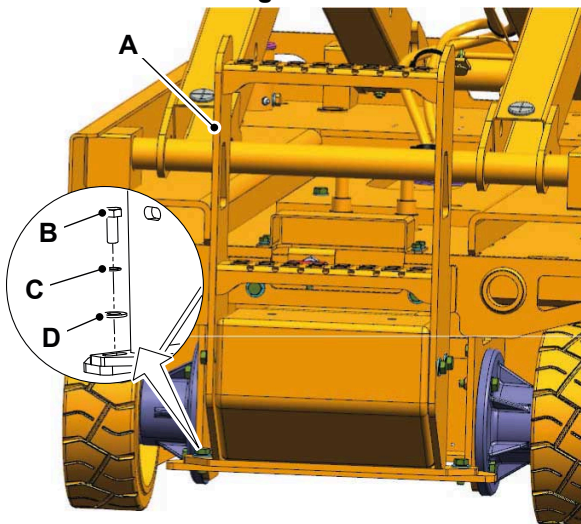
For: S2632E EDRV [RAJ], S2646E EDRV [RAJ], S3246E EDRV [RAJ], S4046E EDRV [RAJ], S4550E EDRV [RAJ] ..... Page 06-29

(For: S1932E EDRV [RAJ])

#### Remove

1. Make the machine safe with the platform lowered.
2. Support the ladder with a suitable lifting equipment.
3. Remove the bolt 1 (x4).
4. Remove the bolt from counterweight.  
[Refer to: PIL 06-57.](#)
5. Remove the ladder away from the machine.

Figure 63.



- A Ladder
- B Bolt (X4)
- C Spring washer (X4)
- D Plan washer (X4)

#### Install

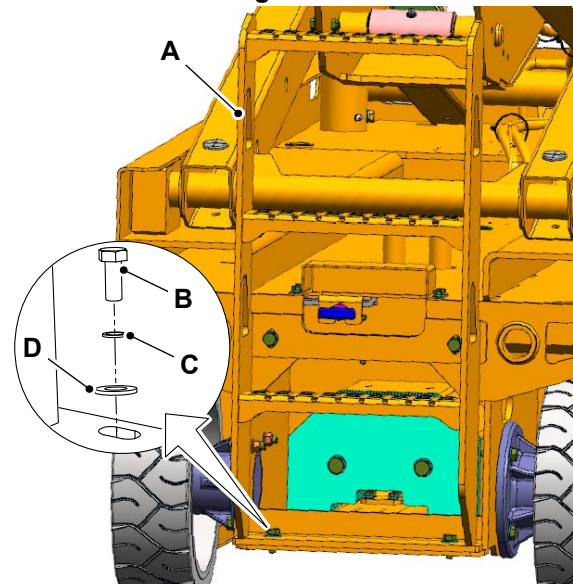
1. The installation procedure is the opposite of the removal procedure.

(For: S2632E EDRV [RAJ], S2646E EDRV [RAJ], S3246E EDRV [RAJ], S4046E EDRV [RAJ], S4550E EDRV [RAJ])

#### Remove

1. Make the machine safe with the platform lowered.
2. Support the ladder with a suitable lifting equipment.
3. Remove the bolt (x4).
4. Remove the ladder away from the machine.

Figure 64.



- A Ladder
- B Bolt (X4)
- C Spring washer (X4)
- D Plan washer (X4)

#### Install

1. The installation procedure is the opposite of the removal procedure.



## 57 - Counterweight

### 00 - General

Introduction .....	06-30
Technical Data .....	06-31
Remove and Install .....	06-31

### Introduction

The counterweights are heavy metal blocks installed in the ladder. The purpose of the counterweights is to provide stability to the machine while in operation.

JCB © CONNOR STANMORE - 13/03/2026 07:57.

## Technical Data

Table 38.

Machine Model	Counterweight
S1932 EDRV	255kg
S2632 EDRV	121kg
S2646 EDRV	415kg
S3246 EDRV	311kg
S4046 EDRV	356kg
S4550 EDRV	193kg

## Remove and Install

For: S1932E EDRV [RAJ] ..... Page 06-31

For: S2632E EDRV [RAJ] ..... Page 06-32

For: S2646E EDRV [RAJ], S3246E EDRV [RAJ], S4046E EDRV [RAJ], S4550E EDRV [RAJ] ..... Page 06-32

(For: S1932E EDRV [RAJ])

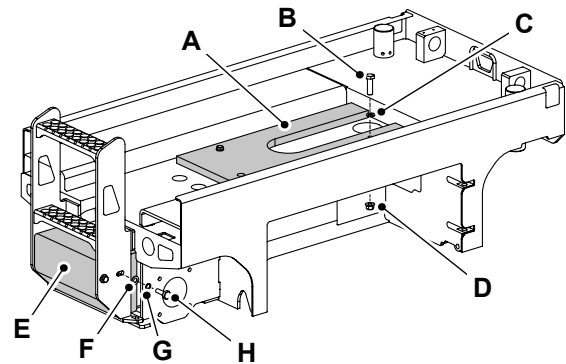
**▲ WARNING** Do not use the machine with the counterweights removed. The counterweights are critical to the stability of machine.

**CAUTION** This component is heavy. It must only be removed or handled using a suitable lifting method and device.

### Remove

1. Make the machine safe.
2. Remove the fastener.
3. Remove the ladder.
4. Remove the counterweight 1 and 2 carefully.
  - 4.1. Make a note of the positions of the counterweights to help installation.

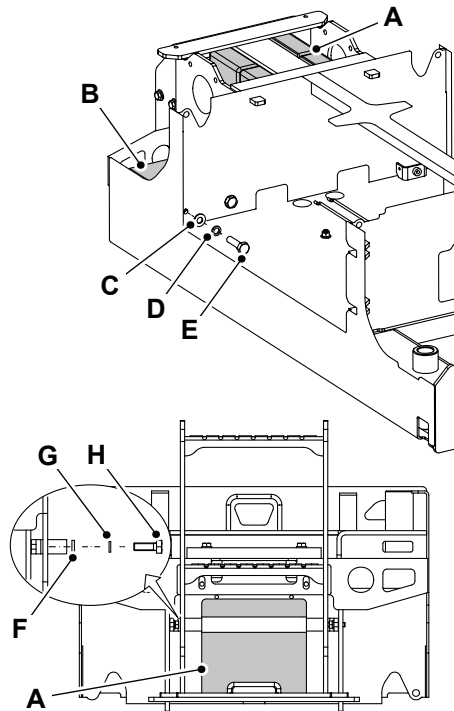
Figure 65.



- A Counterweight 1
- B Bolt 1 (x2)
- C Spring washer 1 (x2)
- D Lock nut 1 (x2)
- E Counterweight 2
- F Bolt 2 (x4)
- G Spring washer 2 (x4)
- H Plain washer 2 (x4)

5. Remove the counterweight 3 and 4 carefully.

Figure 66.



- A Counterweight 3
- B Counterweight 4
- C Plain washer 4 (x3)
- D Spring washer 4 (x3)
- E Bolt 4 (x3)
- F Plain washer 3 (x2)
- G Spring washer 3 (x2)
- H Bolt 3 (x2)

**Install**

1. The installation procedure is the opposite of the removal procedure. Additionally do the following step.
2. Make a note that the weights of the counterweights are different, you must not interchange them.

(For: S2632E EDRV [RAJ])

**▲ WARNING** Do not use the machine with the counterweights removed. The counterweights are critical to the stability of machine.

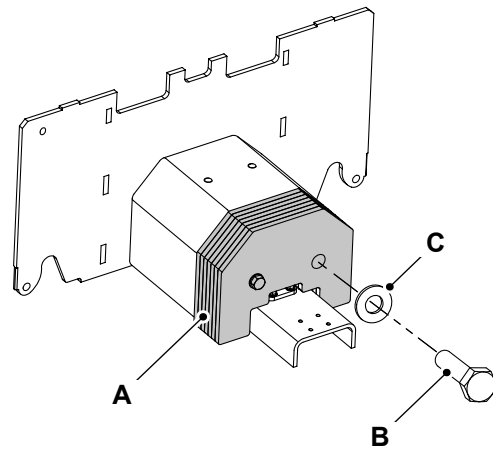
**CAUTION** This component is heavy. It must only be removed or handled using a suitable lifting method and device.

**Remove**

1. Make the machine safe.
2. Remove the fastener.
3. Remove the bracket from counterweight and chassis.

4. Remove the counterweight from chassis.

Figure 67.



- A Counterweight
- B Bolt
- C Washer

**Install**

1. The installation procedure is the opposite of the removal procedure. Additionally do the following step.
2. Make a note that the weights of the counterweights are different, you must not interchange them.

(For: S2646E EDRV [RAJ], S3246E EDRV [RAJ], S4046E EDRV [RAJ], S4550E EDRV [RAJ])

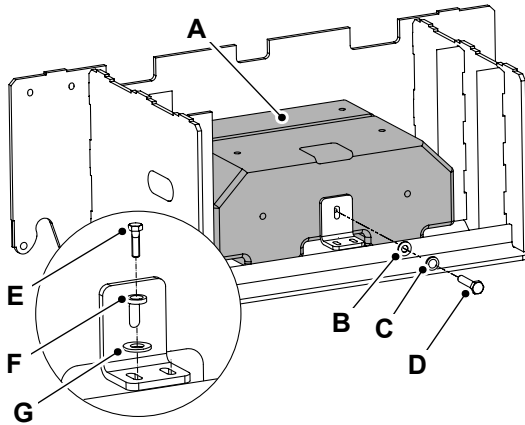
**▲ WARNING** Do not use the machine with the counterweights removed. The counterweights are critical to the stability of machine.

**CAUTION** This component is heavy. It must only be removed or handled using a suitable lifting method and device.

**Remove**

1. Make the machine safe.
2. Remove the fastener.
3. Remove the bracket from counterweight and chassis.
4. Remove the counterweight from chassis.

Figure 68.



- A Counterweight
- B Washer 1
- C Spring washer 1
- D Bolt 1
- E Bolt 2 (X2)
- F Spring washer 2 (X2)
- G Washer 2 (X2)

**Install**

1. The installation procedure is the opposite of the removal procedure. Additionally do the following step.
2. Make a note that the weights of the counterweights are different, you must not interchange them.



## **63 - Identification Label**

### **00 - General**

#### **Introduction**

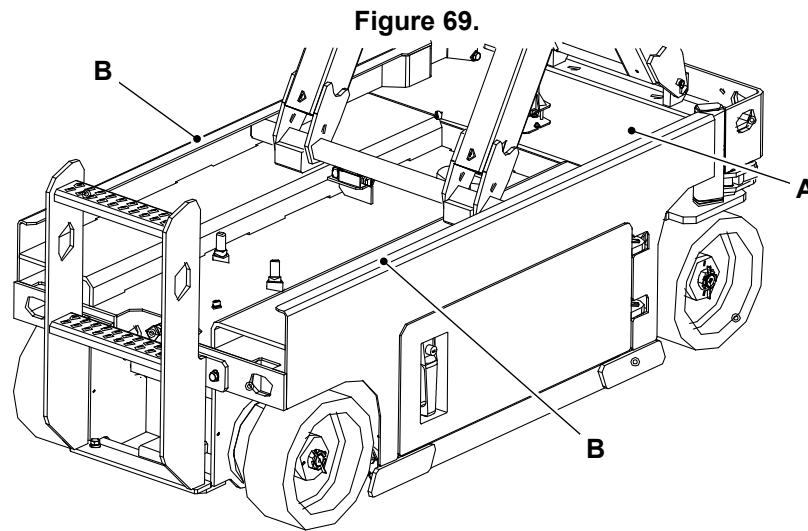
The machine has identification plates that contain important information relating to the specific machine details, for example VIN or PIN number. These serial numbers can help you identify exactly what equipment has been installed on the machine.

## 03 - Machine

### Introduction

Your machine has an identification plate as shown.

Refer to Figure 69.

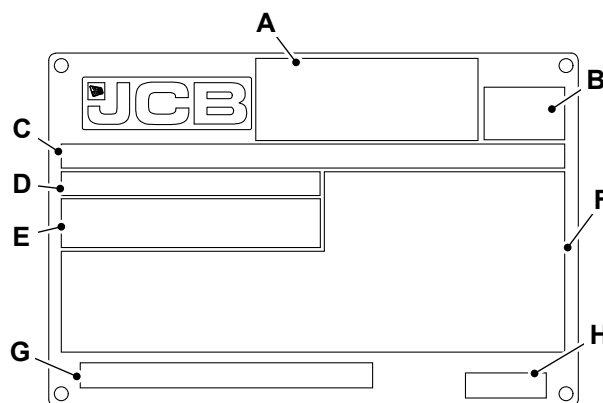


**A** Machine identification plate location

**B** VIN Stamping location

### Explanation of Machine Identification Plate

**Figure 70.**



**Table 39.**

A	Manufacturers address
B	Regional certification mark (if applicable) <sup>(1)</sup>
C	PIN (Product Identification Number) ISO10261
D	Model
E	Model and manufacture year <sup>(2)</sup>
F	Model data



## 06 - Body and Framework

63 - Identification Label

03 - Machine

---

G	Product description and relevant design standards
H	Part number

*(1) This only applies to markets requiring a certification mark. example a CE mark.*

*(2) This only applies to markets requiring a model and manufacture year.*

## **66 - Tools**

### **00 - General**

#### **Introduction**

When you carry tools onto the machine, you must keep three points of contact with the machine at all times. If necessary, lift the tools on to the machine in intervals. Put the tools down before you adjust your grips on the machine. Do not try to adjust your grips on the machine while holding tools.



## 93 - Emergency Lower System

### 00 - General

Introduction .....	06-38
Check (Operation) .....	06-39

### Introduction

The emergency lower system allows the user to lower the platform from the ground in the event of a primary power failure.

Pull the emergency lower handle to lower the platform in an emergency. Before you lower the platform with the emergency lower lever, do the following.

- Make sure that the lowering of the platform is not hindered by obstructions under the scissor arm.
- It may be necessary to retract the extension platform.
- Refer to the applicable Operator's Manual for correct procedure of using emergency lower lever.

## Check (Operation)

**▲ WARNING** Keep hands and arms out of the path of the scissor arms when lowering the platform.

The lowering alarm does not sound while lowering but if the machine is switched ON the fault alarm will sound due to lowering without electrical controls. Lowering may continue.

1. Make the machine safe with the platform lowered.

Refer to: [Introduction \(PIL 01-03-27\)](#).

2. Make sure that the platform extension is in the fully retracted position.

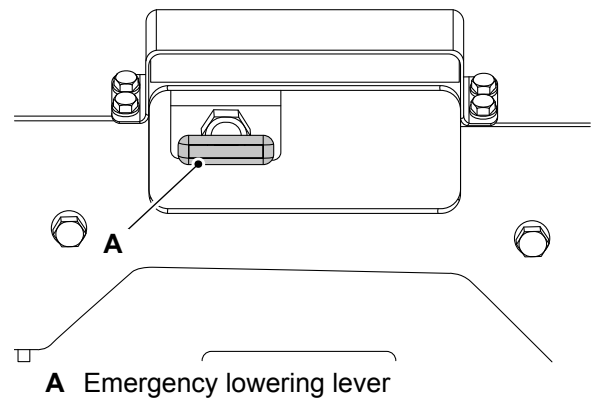
3. Turn the key switch to the ground control position.

4. On the ground controller press the raise/up button to raise the platform.

5. Make sure that the platform is raised to its full height.

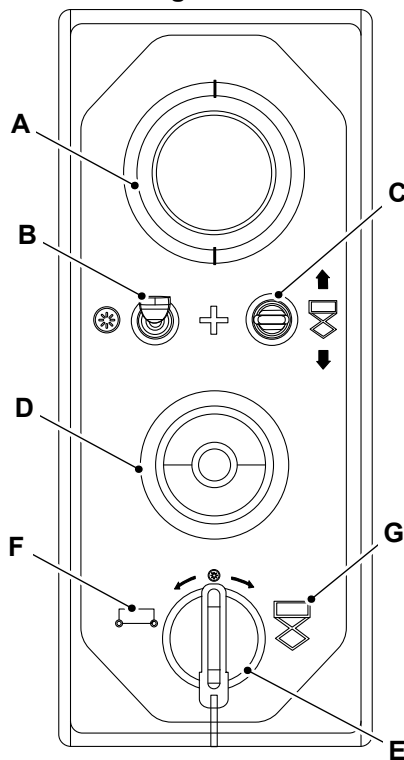
6. Pull the emergency lowering lever.

**Figure 72.**



7. Make sure that the platform is lowered.

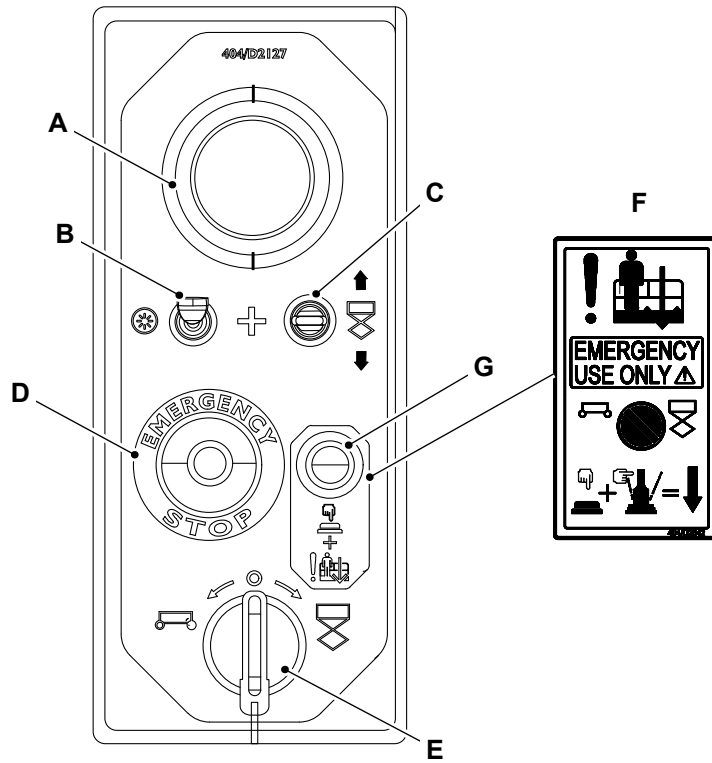
**Figure 71.**



- A Base display
- B Enable switch
- C Up/down switch
- D Emergency stop switch
- E Ignition ON/OFF switch
- F Ground control position
- G Platform control position

Override Function (If Fitted)

Figure 73.



- |   |                                 |
|---|---------------------------------|
| <b>A</b> Base display                             | <b>B</b> Enable switch          |
| <b>C</b> Toggle switch (platform raise and lower) | <b>D</b> Emergency stop switch  |
| <b>E</b> Ignition ON/OFF switch                   | <b>F</b> Emergency decent decal |
| <b>G</b> Override button                          |                                 |

- Press the override button to turn ON the ground controller display.
- When the ground controller display shows 'ORD ACT', press the lower toggle switch along with the override button, and the machine will start lowering
- Releasing the override button will shut down the machine at any time.

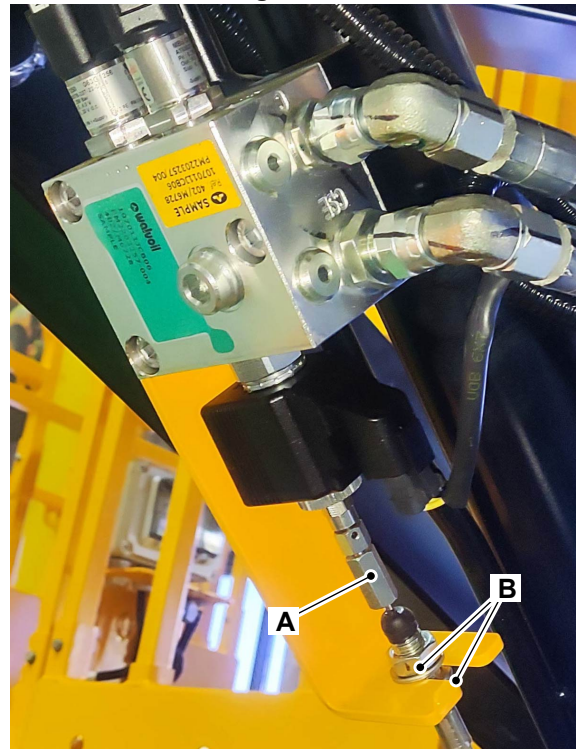
### 03 - Cable

Adjust ..... 06-41  
 Remove and Install ..... 06-42

### Adjust

1. Make the machine safe with the platform raised.  
 Refer to: [Introduction \(PIL 01-03-27\)](#).
2. Install the maintenance strut. Danger or injury will result if the scissor arm is not supported fully.  
 Refer to: [Introduction \(PIL 01-03-27\)](#).
3. Disconnect the quick disconnect handle.  
 Refer to: [Disconnect and Connect \(PIL 33-05-00\)](#).
4. Loosen the locknut (x2).
5. Adjust the cable length as required so that the emergency lower function operates correctly.

**Figure 74.**



- A** Cable
- B** Locknut (x2)

6. Check the operation of the emergency lower system.  
 Refer to: [Check \(Operation\) \(PIL 06-93-00\)](#).
7. If necessary, do the step 1 to 5 again.
8. Tighten the locknut (x2) to lock the position of the cable.
9. Install the maintenance strut.  
 Refer to: [Introduction \(PIL 01-03-27\)](#).
10. Connect the quick disconnect handle.

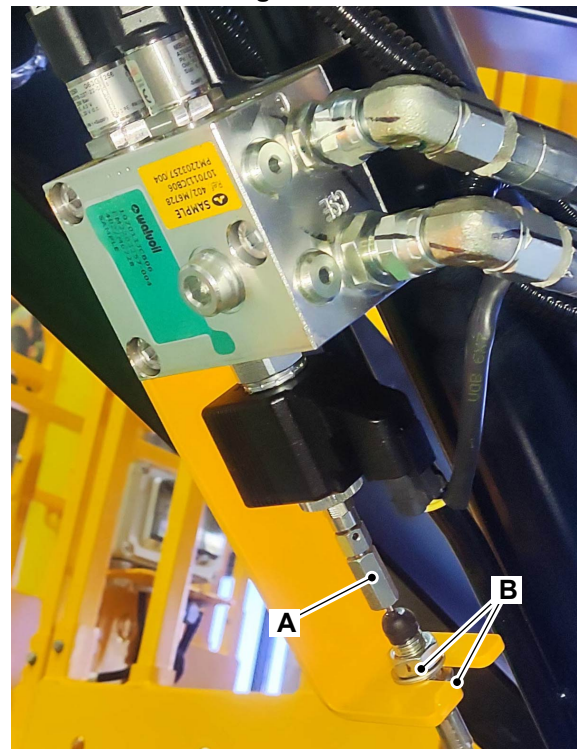
Refer to: Disconnect and Connect (PIL 33-05-00).

## Remove and Install

### Remove

1. Make the machine safe with the platform raised.  
 Refer to: Introduction (PIL 01-03-27).
2. Install the maintenance strut. Danger or injury will result if the scissor arm is not supported fully.  
 Refer to: Introduction (PIL 01-03-27).
3. Disconnect the quick disconnect handle.  
 Refer to: Disconnect and Connect (PIL 33-05-00).
4. Loosen the nut 1 (x2). Refer to Figure 75.
5. Pull out the inside fitting to release the cable at the top.

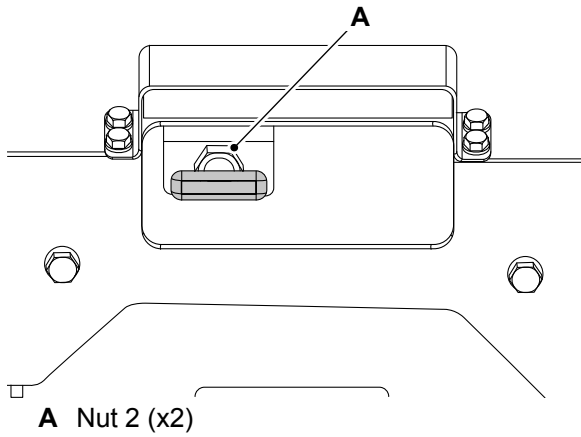
**Figure 75.**



- A** Cable
- B** Nut 1 (x2)

6. Remove the cable ties that secure the cable to the scissor arm.
7. Remove the nut 2 (x2). Refer to Figure 76.
8. Remove the cable slowly through the release handle aperture.

**Figure 76.**



**Install**

1. The installation procedure is the opposite of the removal procedure.
2. Adjust the cable.  
[Refer to: Adjust \(PIL 06-93-03\).](#)

JCB © CONNOR STANMORE - 13/03/2026 07:57.



## 94 - Pothole Protection System

### 00 - General

Introduction .....	06-44
Component Identification .....	06-45
Operation .....	06-47
Check (Operation) .....	06-48

### Introduction

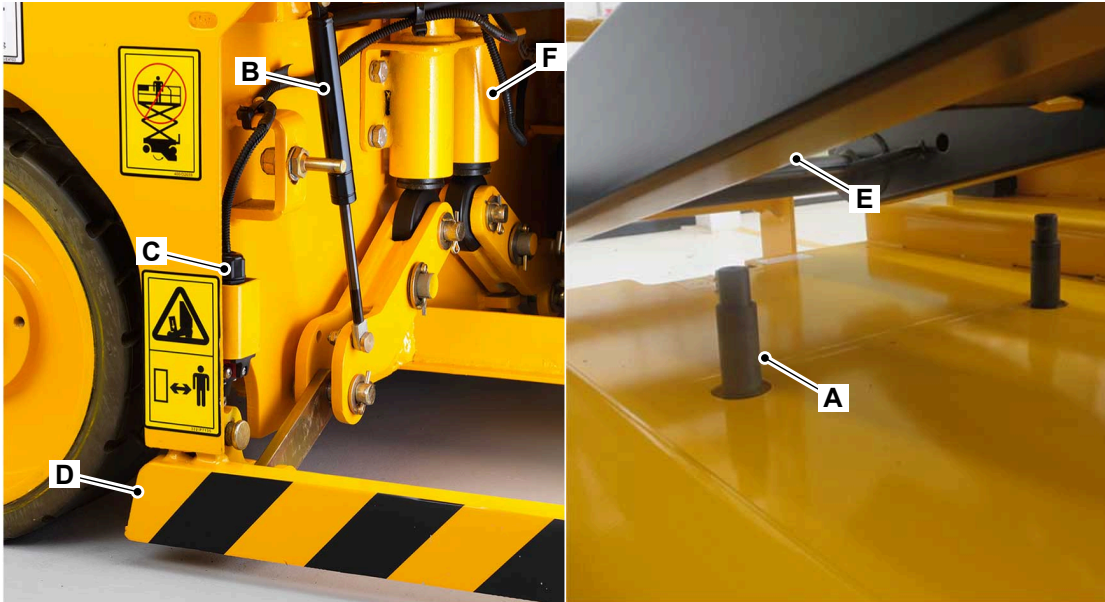
The pothole protection system on these machines helps to prevent the machine from tipping over when one wheel drives off a depression, such as a pothole.

A typical pothole protection system consists of a protection plate, actuator and supporting linkages. The protection plates are extended when the platform is raised, and the protection plates are retracted when the platform is lowered to allow the machine to drive over ramps or obstacles.

JCB © CONNOR STANMORE - 13/03/2026 07:57.

## Component Identification

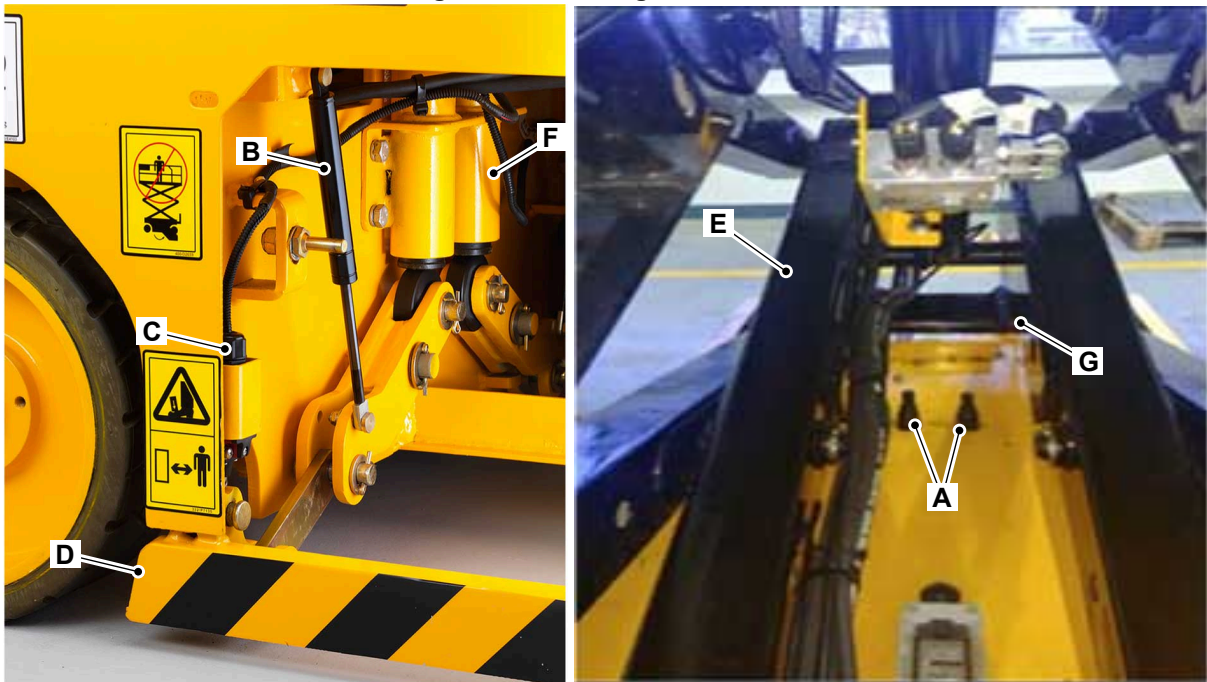
**Figure 77. For Smaller Machines**



- A Actuator rods
- C Protection sensor

- B Gas strut
- D Protection plate
- F Actuator case

**Figure 78. For Larger Machines**



- A Actuator rods

- B Gas strut



**C** Protection sensor  
**E** Scissor arm  
**G** Bracket

**D** Protection plate  
**F** Actuator case

## Operation

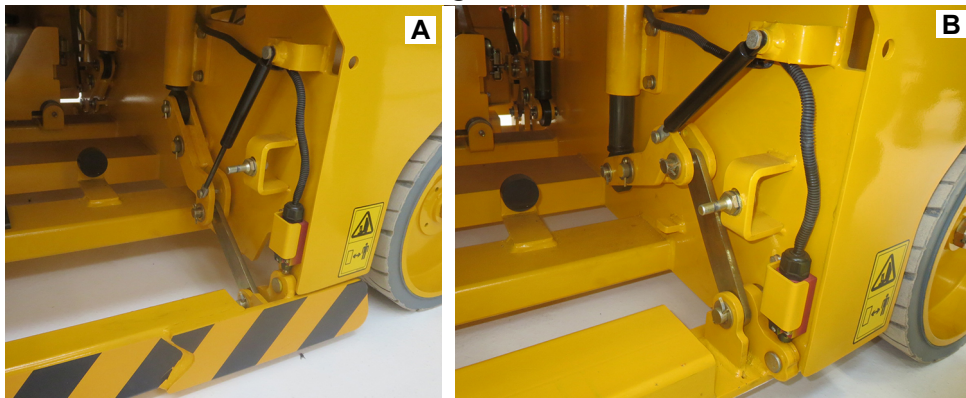
The pothole protection system consists of sensors (x2) and actuator rods (x2).

When the platform rises, the protection plate will open under the action of the weight of the plates and the force of the gas strut. When the platform lowers, the lower scissor arm will press the actuator,

the actuator rod will move downwards, and the protection plate will retract automatically.

You must check the operation of the pothole protection daily to confirm whether the protection plate retracts and extends normally.

**Figure 79.**



**A** Protection plate in extended position (Platform raised)

**B** Protection plate in retracted position (Platform lowered)

### Pothole Protection System - Activation

The pothole protection system should be activated when the platform is elevated. The pothole

protection system is monitored by two limit switches to ensure correct deployment. If the pothole protection system does not activate, the alarm will sound and the platform will not raise any higher.

**Table 40. Disable Raise Pothole Fault (Optional)**

The machine is default set with raise 'Disabled'.	Contact your JCB dealer for configuration.
If the option raise is 'Disabled'.	The machine will stop raising and show error (DTC 56) after the detection of a pothole fault.
If the option raise is 'Enabled'.	The machine will continue to raise even after the detection of a pothole fault.
Drive is disabled on both modes until the fault is cleared. <sup>(1)</sup>	

(1) This feature is available on software version A115 and above.

## Check (Operation)

1. Make the machine safe.  
[Refer to: Introduction \(PIL 01-03-27\).](#)
2. Lower the platform to the stowed position.
3. Place a block under the pothole plate on one side.
4. Use the ground controls to raise the platform.
  - 4.1. The pothole protection alarm should trigger when the scissor is raised off the down limit switch.
5. Check the machine operation.
  - 5.1. All functions except lowering should be disabled.

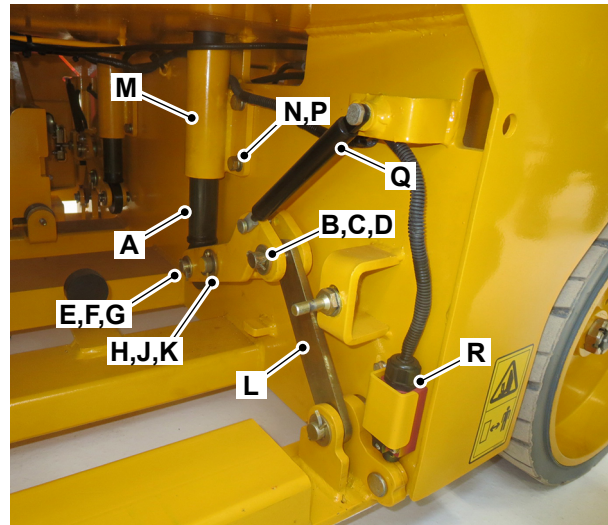
## 04 - Actuator Rod

### Remove and Install

#### Remove

1. Make the machine safe with the platform raised.  
[Refer to: Introduction \(PIL 01-03-27\).](#)
2. Disconnect the battery quick disconnect handle.  
[Refer to: Disconnect and Connect \(PIL 33-05-00\).](#)
3. If necessary, remove the pothole protection switch.  
[Refer to: Remove and Install \(PIL 33-84-82\).](#)
4. Remove the gas strut.  
[Refer to: Remove and Install \(PIL 06-45-45\).](#)
5. Remove the split pin 1 (x2) and washer 1 (x2).
6. Lever out the pivot pin 1 (x2).
7. Disconnect the lever link arm (x2) from the pivot link arm.
8. Remove the split pin 2 (x2) and washer 2 (x3).
9. Support the actuator rod suitably.
10. Lever out the pivot pin 2 (x2).
11. Slowly remove the actuator rod (x2) from the guide sleeve (x2).
12. If necessary, remove the pivot link arm as follows.
  - 12.1. Remove the split pin 3 (x2) and washer 3 (x3).
  - 12.2. Remove the pivot link arm from the machine.
  - 12.3. Lever out the pivot pin 3 (x2).
13. If necessary, remove the guide sleeve as follows.
  - 13.1. Remove the bolt (x4), washer 4 (x8)
  - 13.2. Remove the guide sleeve (x2) from the machine.

Figure 80.



- A** Actuator rod
- B** Split pin 1 (x2)
- C** Washer 1 (x2)
- D** Pivot pin 1 (x2)
- E** Split pin 2 (x2)
- F** Washer 2 (x2)
- G** Pivot pin 2 (x2)
- H** Split pin 3 (x2)
- J** Washer 3 (x2)
- K** Pivot pin 3 (x2)
- L** Lever link arm
- M** Guide sleeve
- N** Bolts (x4)
- P** Washers 4 (x8)
- Q** Gas strut
- R** Pothole protection switch (x2)

#### Install

1. The installation procedure is the opposite of the removal procedure.
2. Apply grease to the pivot pins in accordance with the maintenance schedules.

[Refer to: PIL 78-24.](#)

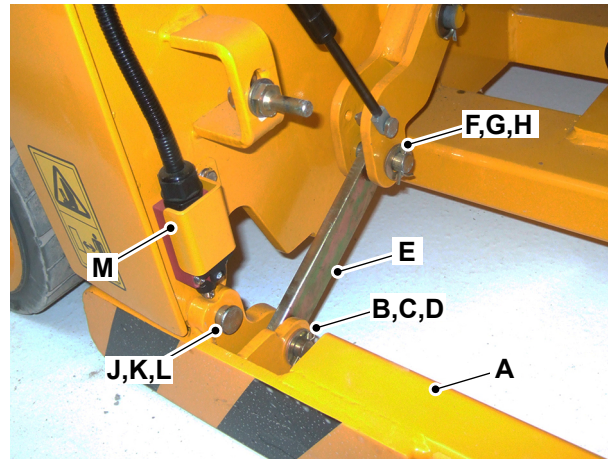
## 06 - Plate

### Remove and Install

#### Remove

1. Make the machine safe with the platform lowered.  
[Refer to: Introduction \(PIL 01-03-27\).](#)
2. Disconnect the battery quick disconnect handle.  
[Refer to: Disconnect and Connect \(PIL 33-05-00\).](#)
3. If necessary, remove the pothole protection switch.  
[Refer to: Remove and Install \(PIL 33-84-82\).](#)
4. Remove the split pin 1 (x2) and washer 1 (x2).
5. Lever out the pivot pin 1 (x2).
6. Disconnect the lever link (x2) from the pothole protection plate.
7. If necessary, remove the lever links as follows.
  - 7.1. Remove the split pin 2 (x2) and washer 2 (x2).
  - 7.2. Lever out the pivot pin 2 (x2).
  - 7.3. Remove the lever link (x2).
8. Remove the split pin 3 (x2) and washer 3 (x3).
9. Lever out the pivot pin 3 (x2).
10. Remove the pothole protection plate from the machine.

Figure 81.



- A** Pothole protection plate
- B** Split pin 1 (x2)
- C** Washer 1 (x2)
- D** Pivot pin 1 (x2)
- E** Lever link
- F** Split pin 2 (x2)
- G** Washer 2 (x2)
- H** Pivot pin 2 (x2)
- J** Split pin 3 (x2)
- K** Washer 3 (x2)
- L** Pivot pin 3 (x2)
- M** Pothole protection switch (x2)

#### Install

1. The installation procedure is the opposite of the removal procedure.
2. Apply specified grease to the pivot pins in accordance with the Maintenance Schedules.  
[Refer to: Technical Data \(PIL 75-00-00\).](#)



## 97 - Platform

### 00 - General

Introduction .....	06-51
Health and Safety .....	06-52
Check (Condition) .....	06-53
Remove and Install .....	06-54

### Introduction

The platform is mounted on top of the lift or scissor arm. The platform consists of the following parts:

- Gate.
- Guardrail.
- Main platform.
- Platform extension.

The machine is equipped with the optional features given below for the platform safety. The optional features can be accessed through passcode only.

[Refer to: Operation \(PIL 06-97-00\).](#)

- Over-rise system (only for South-East Asia).
- Elevated drive prevention (only for South-East Asia).

## Health and Safety

▲ **WARNING** Control lever/switch action may vary on machines, instructional labels near the levers/switches show by symbols, which levers/switches cause what actions. Before operating control levers/switches check the instructional label to make sure you select the desired action.

**WARNING** To operate the machine safely you must have received the appropriate training. The operator's manual instructs you on the machine, its controls and its safe operation; it is not a training manual. Ensure that you receive the correct training before operating the machine. Failure to do so will result in incorrect operation of the machine and you will be putting yourself and others at risk. You must abide by all local site regulations. Make sure that you and your machine comply with relevant local laws and jobsite requirements – it is your responsibility.

**WARNING** Make sure it is clear overhead before raising the platform. Keep an adequate safe distance from all electrical power lines. Contact your local power company for safety procedures.

**WARNING** Notice boards or panels must not be installed on the platform because they will increase wind resistance.

**WARNING** Do not use the platform as a crane.

**WARNING** Do not extend the reach or height of the platform by the use of ladders or other equipment.

**WARNING** Do not use the platform when the wind speed exceeds the rated limit, stated in the operators manual.

**WARNING** Do not allow the machine to come in to contact with fixed objects, buildings etc.

**WARNING** Do not allow the machine to come in to contact with moving objects, vehicles, cranes etc.

**WARNING** Do not exceed the maximum rated load stated on the platform.

**WARNING** All operators must be adequately trained and authorised to use the machine.

**WARNING** All operators must make sure there is a restricted area under or around the platform to safeguard against falling objects injuring bystanders or colleagues.

**WARNING** All operators must use the correct safety harnesses when operating from the platform. Hard hats with chin straps must also be worn.

**WARNING** Do not operate the machine from the base controls with personnel in the platform, except when you need to lower the platform in an

emergency using the procedure in the operators manual.

If the platform cannot be lowered by the use of the emergency controls, personnel must be removed using other means.

You must not work on the machine whilst personnel are in the platform.

## Check (Condition)

**▲ WARNING** If one or more of these faults are found, make sure the machine is not used until the fault has been correctly repaired or the component replaced.

**Notice:** These checks do not replace inspections that are necessary to obey local or national regulations applicable in your area.

## Remote Mode Pre- Operation Checks

Prior to commencing work from the platform, the following functions must be checked (refer to the Operators Manual):

1. Machine isolation from the operator station.
2. Machine isolation from the platform.
3. Emergency Lowering.

## Checking For Damage

1. These checks are not a substitute for inspections to meet the prevailing regulations in your territory.
  - 1.1. Platforms should be inspected daily prior to use to ensure structural soundness and correct operation.

## Check the Platform Structure

1. Inspect all steelwork for damage. Pay particular attention to the following:
  - 1.1. Inspect all lifting point welds.
  - 1.2. Inspect all pivot point welds.
  - 1.3. Inspect all lanyard anchor points.
  - 1.4. Inspect the condition of all pivot pins.
  - 1.5. Check pivot pins are correctly in place and secured by their locking devices.
2. Check handrails and toeplates are undamaged and secure.
3. Check gates are undamaged and secure.
4. Check all safety and instructional labels are in place and undamaged. Install new labels where necessary.
5. Note damaged paintwork for future repair.

## Check the Electrical Circuits

1. Inspect the electrical circuits regularly for:
  - 1.1. Damaged connectors.
  - 1.2. Loose connections.
  - 1.3. Chafing on wiring harnesses.
  - 1.4. Corrosion.
  - 1.5. Missing insulation.
  - 1.6. Incorrect routing of harness.
2. Do not use the machine if one or more of these faults are found. You must make sure that the electrical circuit is repaired immediately.
3. Perform the daily checks as stated in the machine operator's manual.

## Pipe Cradle Post (Accessory)

1. Inspect the condition of the welds on the pipe cradle post.
2. Check that the safety and instructional labels are in place and undamaged.
  - 2.1. Replace damaged labels with new ones when required.
3. Check for missing or damaged components. Replace, if necessary.
4. Check the condition of fasteners. Replace, if necessary.

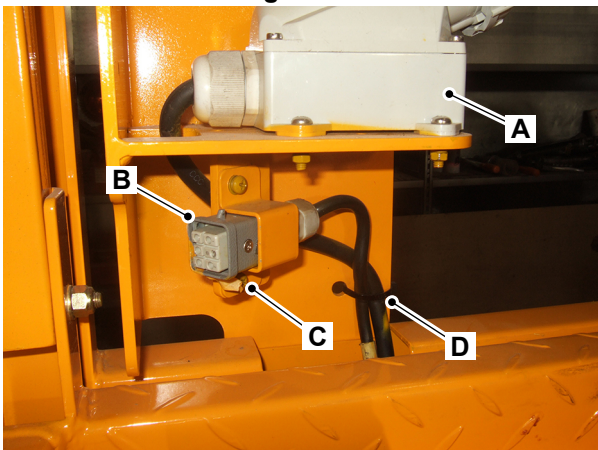
## Remove and Install

**▲ CAUTION** This component is heavy. It must only be removed or handled using a suitable lifting method and device.

### Remove

1. Make the machine safe with the platform lowered.  
[Refer to: Introduction \(PIL 01-03-27\).](#)
2. Disconnect the external power supply, and set the emergency stop switches of the platform and ground control panels at the OFF position.
3. Find the cable connected to the bottom of the platform control box assembly.
4. Remove the cable ties.
5. Disconnect the cable from the bottom of the control box.
6. Remove the screws, remove the platform control box assembly and mounting brackets, and remove the control cable away from the working platform.
7. (If installed) Remove the screws, remove the AC (Alternating Current) power socket away from the mounting bracket.

**Figure 82.**



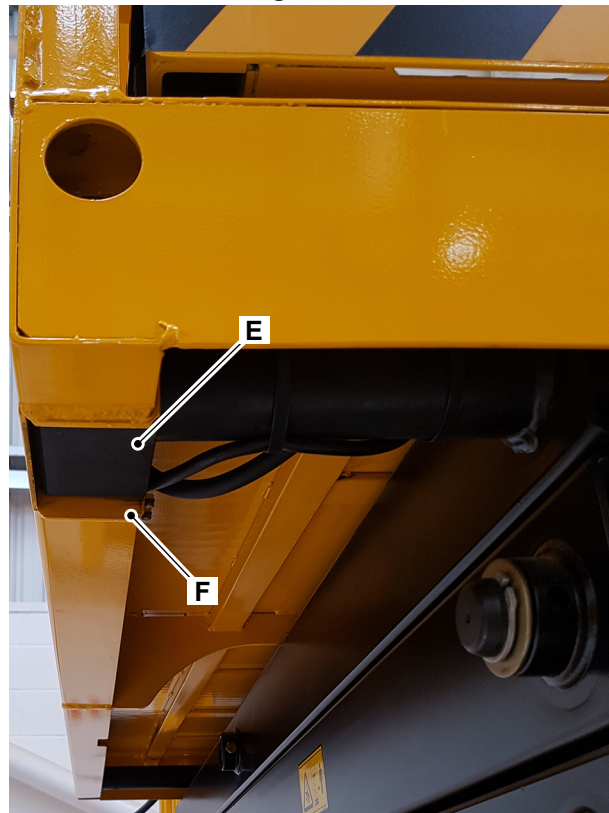
- A AC power socket
- B Platform controller power socket
- C Screws (x2)
- D Cable Tie

8. Disassemble the AC and platform power socket. Disconnect the harnesses and feed through the aperture in the base of the platform.

[Refer to: Remove and Install \(PIL 33-95-75\).](#)

9. Use a suitable lifting hoist with straps positioned under the platform base to carefully raise the platform slightly.
10. Raise and push the platform forwards to allow the slider block to clear the gap at the rear of the platform base.
11. Remove the platform away from the machine.

**Figure 83.**



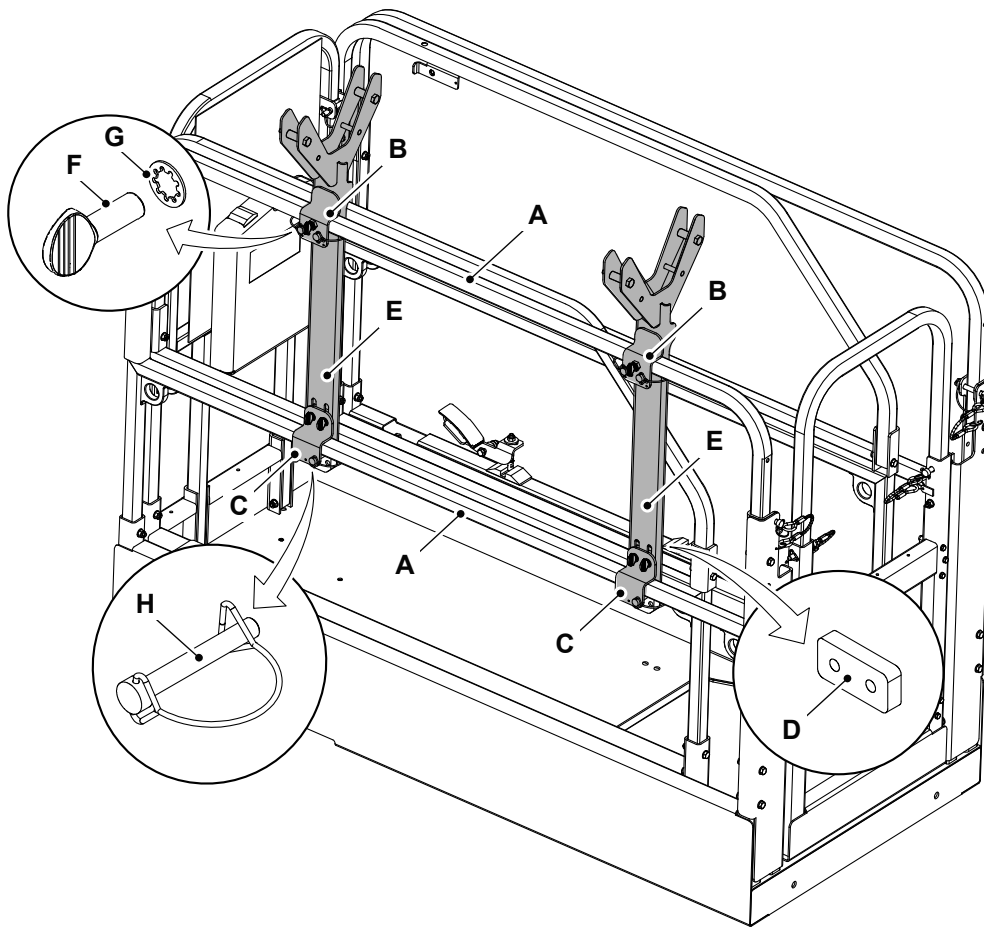
- E Rear slider
- F Gap at rear of platform base

### Install

1. The installation procedure is the opposite of the removal procedure.

### Pipe Cradle Post (Accessory)

It is important to ensure that precautions are taken and two service personnel are available during this procedure.

**Figure 84.**


- A** Guardrails
- C** Bottom bracket (x2)
- E** Pipe cradle post (x2)
- G** Toothed lock washer (x6)

- B** Upper bracket (x2)
- D** Back plate (x2)
- F** Thumb screw (x6)
- H** Shaft locking pin (x6)

**Install**

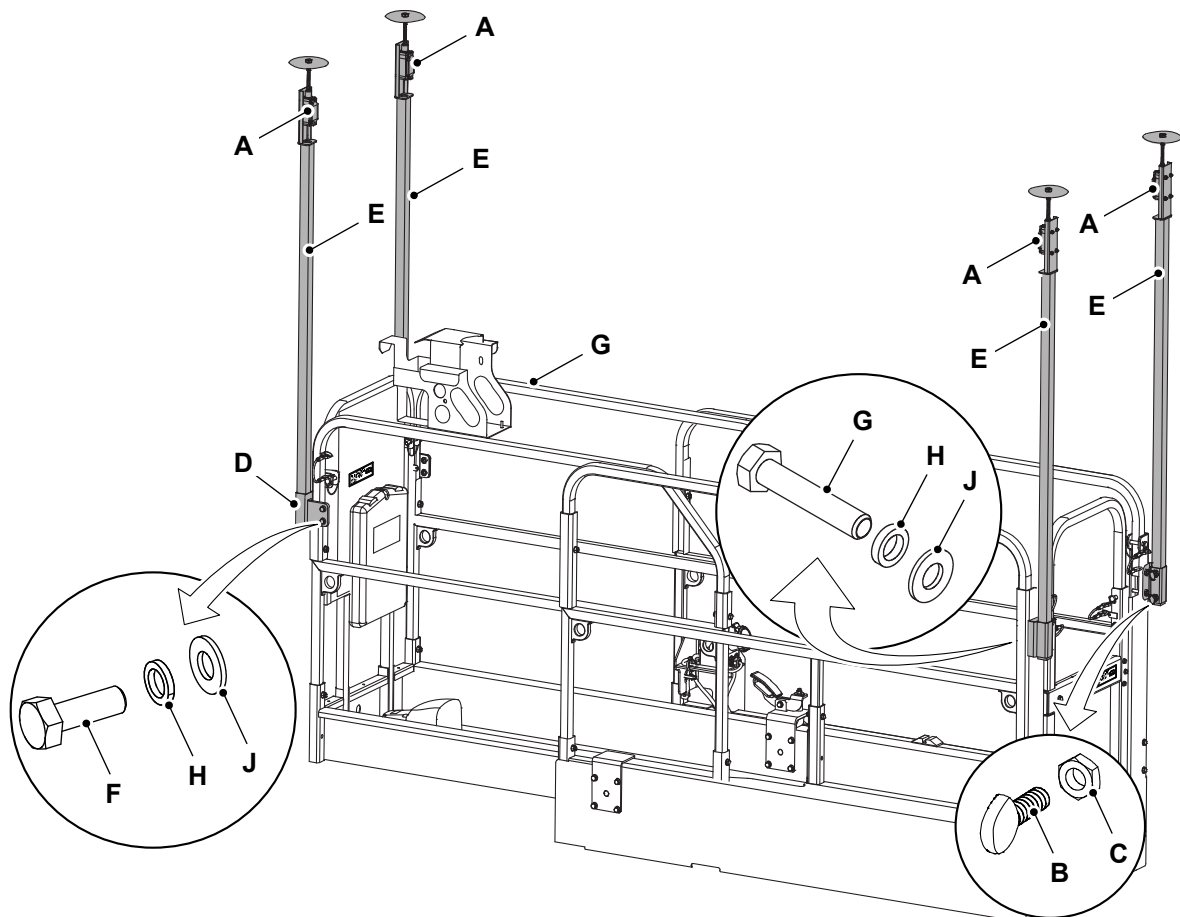
1. Make the machine safe.  
[Refer to: PIL 01-03-27.](#)
2. Get access to the platform to install the pipe cradle post (x2) on the guardrails. [Refer to Figure 84.](#)
3. Safely hang the pipe cradle post (x2) on the guardrails with the upper bracket (x2). [Refer to Figure 84.](#)
4. Match the holes on the upper bracket (x2) with the holes on the guardrails and install the thumb

screw (x2) and toothed lock washer (x2). [Refer to Figure 84.](#)

5. Use the thumb screw (x4) and toothed lock washer (x4) to install the bottom bracket (x2) and back plate (x2). [Refer to Figure 84.](#)
6. Install the shaft locking pin (x6) on the upper and bottom brackets of the pipe cradle post (x2). [Refer to Figure 84.](#)

**Remove**

1. The removal procedure is the opposite of the installation procedure.

**Overrise System (Only for South-East Asia)**
**Remove**
**Figure 85.**

**A** Limit switch (x4)

**C** Thin nut (x8)

**E** Overrise prevention post (x4)

**G** Bolt (x4)

**J** Washer (x8)

**B** Thumb screw (x8)

**D** Bracket (x4)

**F** Setscrew (x4)

**H** Spring washer (x8)

1. Make the machine safe with the platform lowered.  
[Refer to: PIL 01-03-27.](#)
2. Disconnect the battery quick disconnect handle.  
[Refer to: PIL 33-05-00.](#)
3. Disconnect the external power supply, and set the emergency stop switches of the platform and ground control panels to the OFF position.
4. Access the overrise system mounted onto the top of the platform.
5. Disconnect the electrical connections from the limit switch (x4). [Refer to Figure 85.](#)
6. Loosen and remove the thumb screw (x8) and thin nut (x8) from the bracket (x4). [Refer to Figure 85.](#)
7. Remove the over-raise prevention post (x4) along with the limit switch (x4) from the bracket (x4). [Refer to Figure 85.](#)
8. If necessary, remove the bolt (x4), spring washer (x4) and washer (x4) from the fixed platform fence to remove the rear bracket (x2). [Refer to Figure 85.](#)

9. If necessary, remove the setscrew (x4), spring washer (x4) and washer (x4) from the extension platform fence to remove the front bracket (x2). Refer to [Figure 85](#).

**Install**

1. The installation procedure is the opposite of the removal procedure. Additionally do the following step.
2. Tighten the fasteners to the specified torque value. Refer to [Table 40](#).

**Table 40. Torque Values**

Item	Nm
F	22
G	22



### 03 - Platform Extension

Introduction ..... 06-58  
Open and Close ..... 06-59  
Remove and Install ..... 06-60

### Introduction

The platform extension allows the operator to laterally increase the walking area on the platform.

Due to space restrictions, the machine cannot be parked immediately adjacent to the work at ground level, but at some height above the ground this restriction is no longer an issue. At such instances you may use the platform extension to get better access to the work place.

Press the platform extension pedal and push the platform extension forwards as required to extend the platform extension.

JCB © CONNOR STANMORE - 13/03/2026 07:57.

## Open and Close

**▲ WARNING** Do not exceed the maximum rated load stated on the platform.

**WARNING** Do not stand on the extension platform while it is moving or not fixed.

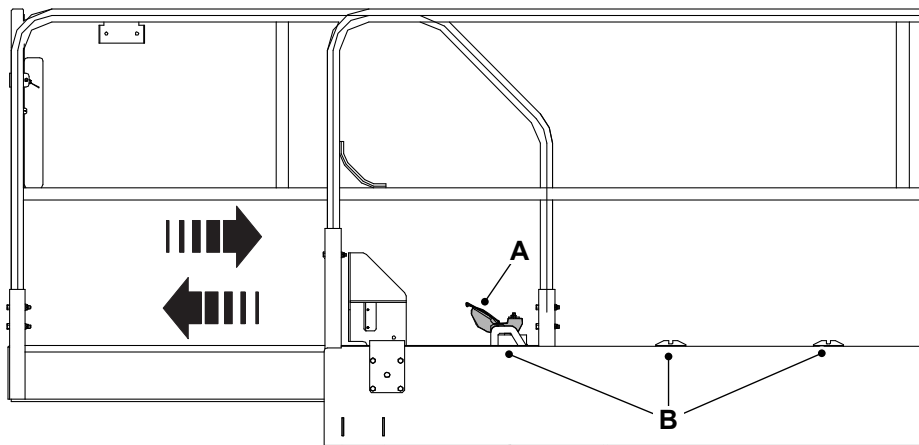
**CAUTION** Do not lower the platform without completely retracting the platform extension.

Make sure that platform door is latched correctly before extending or retracting the platform.

There are three fixing positions for the extending platform

1. Press the pedal.
2. Hold and push the extension platform guard rail.
3. Release the pedal when the rail is in one of the three fixing positions. Make sure that it is engaged correctly.

Figure 86.



**A** Pedal

**B** Fixing positions

4. Press the pedal and pull the extended guardrail to retract the platform.

### Remove and Install

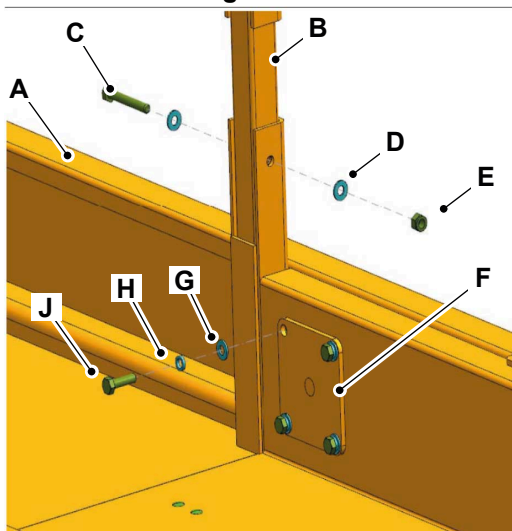
(For: S1932E EDRV, S2632E EDRV, S3246E EDRV)

**▲ CAUTION** This component is heavy. It must only be removed or handled using a suitable lifting method and device.

#### Remove

1. Make the machine safe.  
[Refer to: PIL 01-03-27.](#)
2. Disconnect the battery quick disconnect handle.  
[Refer to: Disconnect and Connect \(PIL 33-05-00\).](#)
3. Remove the AC (Alternating Current) connector and the mounting bracket from the platform.  
[Refer to: Remove and Install \(PIL 33-95-75\).](#)
4. Remove the platform control cradle from the platform position.
5. Remove the platform extension pedal.  
[Refer to: Remove and Install \(PIL 06-97-30\).](#)
6. Remove the fasteners from the lock plate.

**Figure 87.**



- A Platform extension
- B Guardrails
- C Bolts
- D Washers
- E Nuts
- F Lock plate
- G Washers (X4)
- H Spring washers (X4)
- J Bolts (X4)

7. Support the platform extension with suitable lifting equipment.
8. Carefully slide out the platform extension forwards.

**Figure 88.**



- A Platform extension
- J Platform

9. Remove the platform extension from the platform.
10. If necessary, remove the guardrails.
  - 10.1. Remove the fastener.
  - 10.2. Remove the guardrails from the platform extension.

#### Install

1. The installation procedure is the opposite of the removal procedure.



## 06 - Guardrail

Open and Close ..... 06-61  
 Remove and Install ..... 06-64

## Open and Close

For: S1932E EDRV [RAJ] ..... Page 06-61

For: S1932E EDRV [RAJ], S2632E EDRV [RAJ], S2646E EDRV [RAJ], S3246E EDRV [RAJ], S4046E EDRV [RAJ], S4550E EDRV [RAJ] ..... Page 06-62

(For: S1932E EDRV [RAJ])

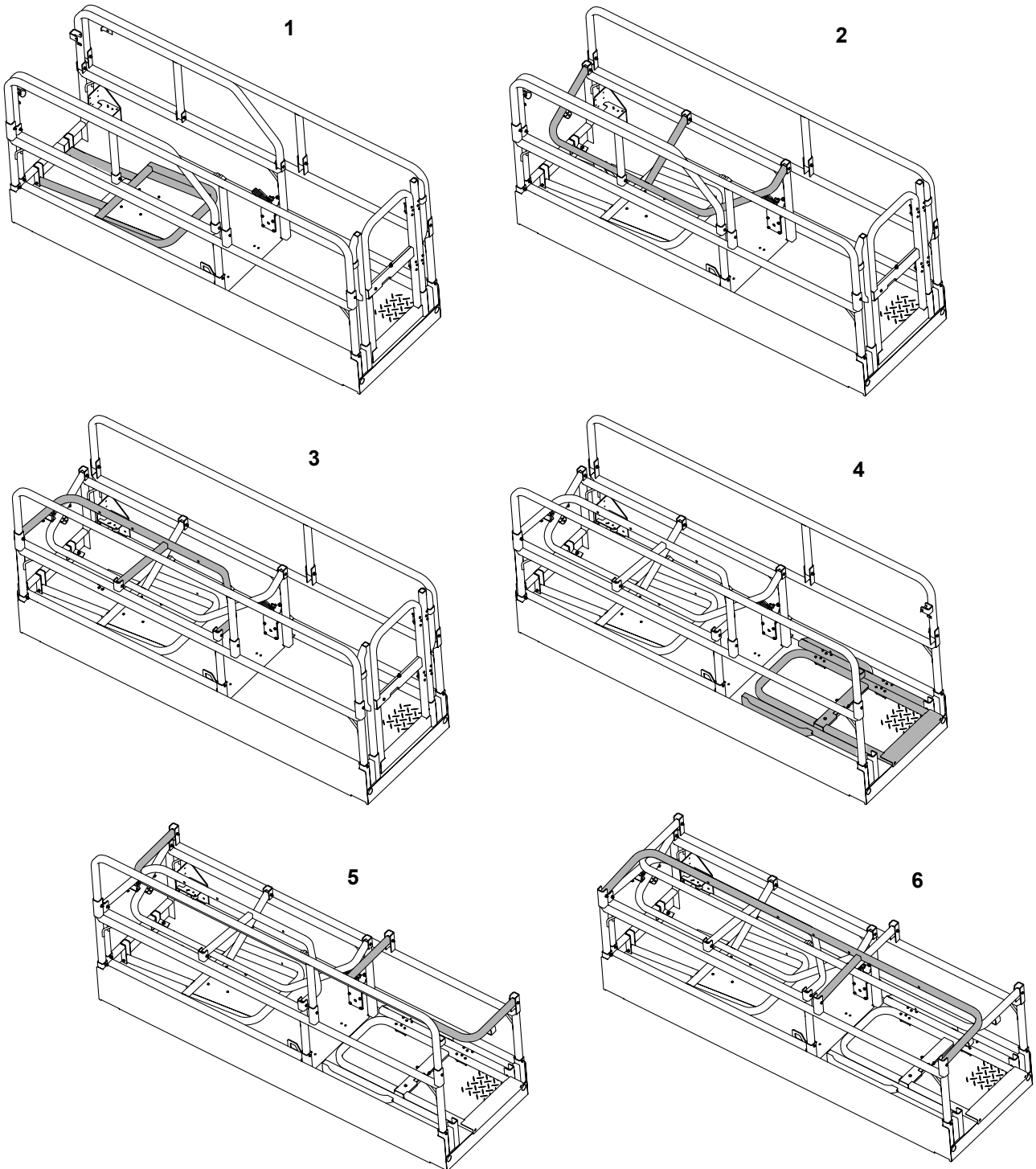
**▲ CAUTION** If the guardrails have been folded down, use extreme caution when entering and leaving the operator station. Do not operate the controls from the platform when the guard rails are folded.

Fold the guardrails in order as shown. [Refer to Figure 89.](#)

1. To fold down each of guardrail, remove the lock pin for that guardrail.
2. Take a firm hold on the top of the guardrail, carefully lower it until it is fully folded. Follow the sequence of folding order

For unfolding the guardrails, follow the reverse sequence of folding order. Make sure that each lock pin is installed when guardrails are unfolded.

Figure 89.



(For: S1932E EDRV [RAJ], S2632E EDRV [RAJ], S2646E EDRV [RAJ], S3246E EDRV [RAJ], S4046E EDRV [RAJ], S4550E EDRV [RAJ])

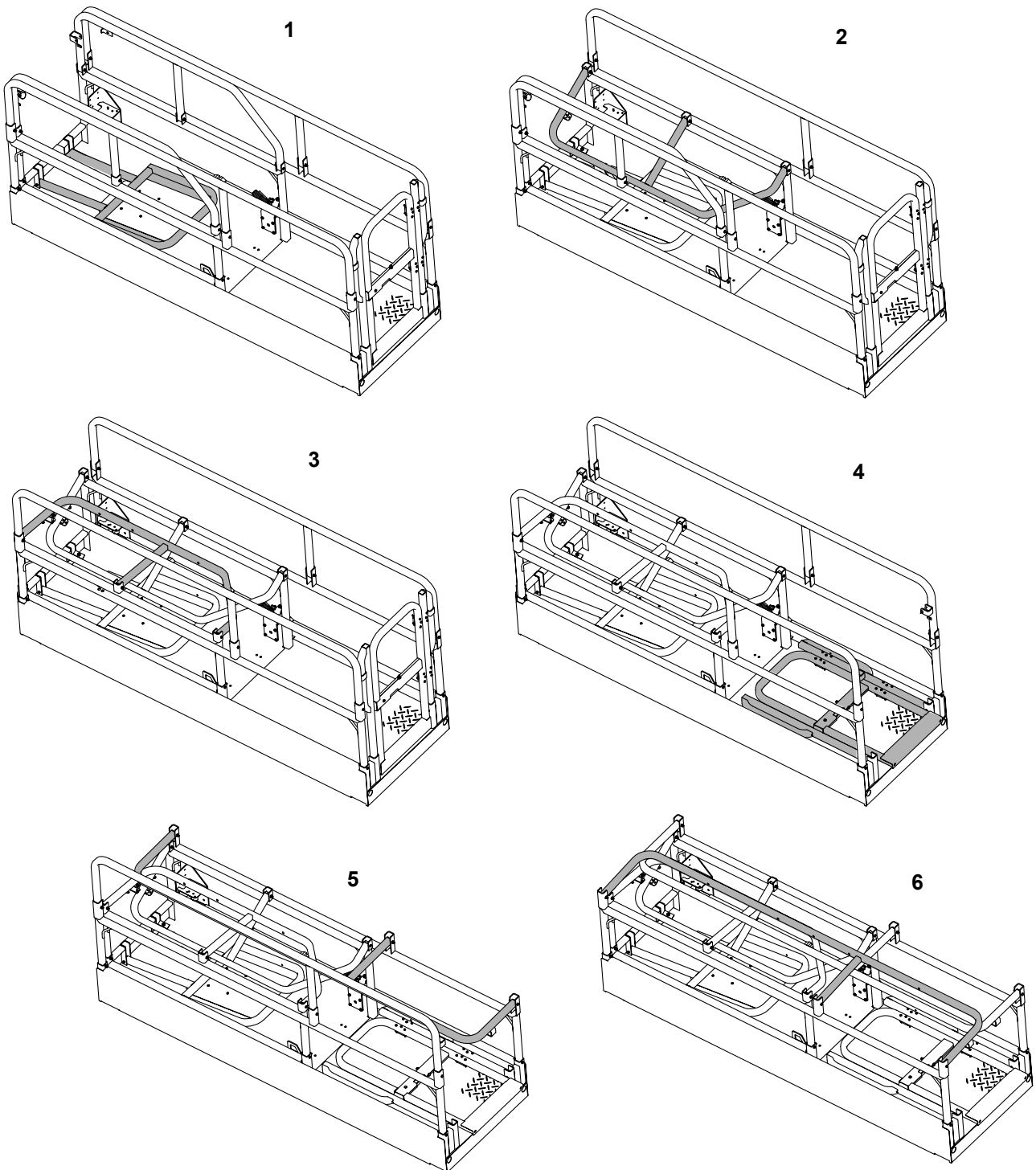
**▲ CAUTION** If the guardrails have been folded down, use extreme caution when entering and

leaving the operator station. Do not operate the controls from the platform when the guard rails are folded.

Fold the guardrails in order as shown. Refer to [Figure 90](#).

1. To fold down each of guardrail, remove the lock pin for that guardrail.
2. Take a firm hold on the top of the guardrail, carefully lower it until it is fully folded. Follow the sequence of folding order

For unfolding the guardrails, follow the reverse sequence of folding order. Make sure that each lock pin is installed when guardrails are unfolded.

**Figure 90.**

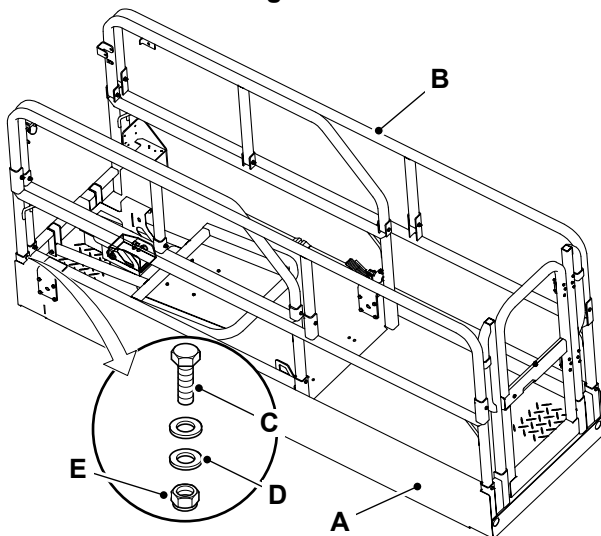
## Remove and Install

**▲ CAUTION** This component is heavy. It must only be removed or handled using a suitable lifting method and device.

### Remove

1. Make the machine safe.  
Refer to: [Introduction \(PIL 01-03-27\)](#).
2. Disconnect the battery quick disconnect handle.  
Refer to: [Disconnect and Connect \(PIL 33-05-00\)](#).
3. Remove the platform control cradle from the platform position.
4. Support the guardrails with suitable lifting equipment.
5. Remove the bolts, nuts and washers from the relevant guardrails.

**Figure 91.**



- A Platform
- B Guardrail
- C Bolts
- D Washers
- E Nuts

6. Remove the locking pins.
7. Slowly remove the each guardrail.

**Figure 92.**



**F** Locking pin

### Install

1. The installation procedure is the opposite of the removal procedure. Additionally do the following steps.
2. Tighten the nuts to the correct torque value.
3. Check the operation of folding guardrails.

## 09 - Gate

### Remove and Install

#### Remove

1. Make the machine safe with the platform lowered.

[Refer to: PIL 01-03-27.](#)

2. Close the platform gate and make sure it latches correctly.

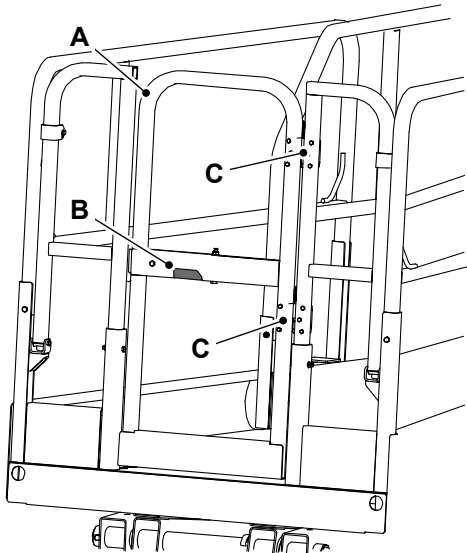
3. Remove the gate hinges.

[Refer to: Remove and Install \(PIL 06-97-12\).](#)

4. Depress the lever.

5. Remove the gate from the machine.

**Figure 93.**



- A** Gate
- B** Lever
- C** Hinge

#### Install

1. The installation procedure is the opposite of the removal procedure.

## 12 - Gate Hinge

### Remove and Install

The following procedure is for the removal of one gate hinge, the procedure for the other gate hinge is similar.

#### Remove

1. Make the machine safe with the platform lowered.  
[Refer to: Introduction \(PIL 01-03-27\).](#)
2. Remove the bolts (x6), nuts (x6) and washers.
3. Support the gate.
4. Remove the gate hinge.

**Figure 94.**



- A Gate hinge
- B Bolts (x6)
- C Nuts (x6)
- D Gate

#### Install

1. The installation procedure is the opposite of the removal procedure.
2. Tighten the bolts to the correct torque value.

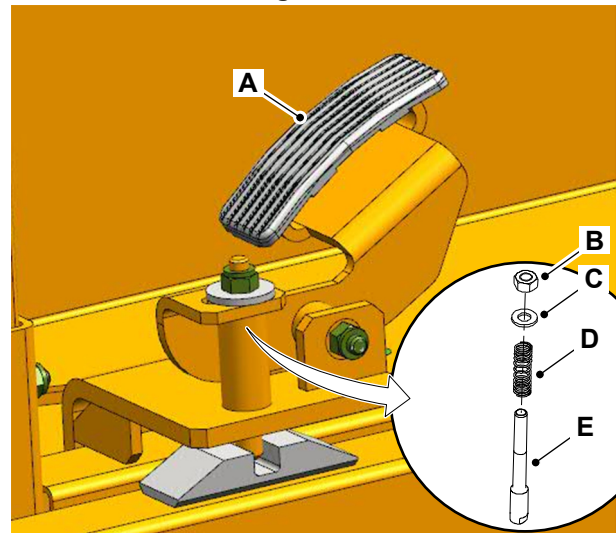
### 30 - Extension Pedal

Lubricate .....	06-67
Remove and Install .....	06-68

### Lubricate

1. Make the machine safe.  
[Refer to: PIL 01-03-27.](#)
2. Press and hold the extension pedal.
3. Apply grease on the pin.
4. If necessary, do the following.
  - 4.1. Remove the nut, washer, spring and pin.
  - 4.2. Apply grease to the pin.
  - 4.3. Install the pin, spring washer and nut.

**Figure 95.**



- A Pedal
- B Nut
- C Washer
- D Spring
- E Pin

## Remove and Install

### Remove

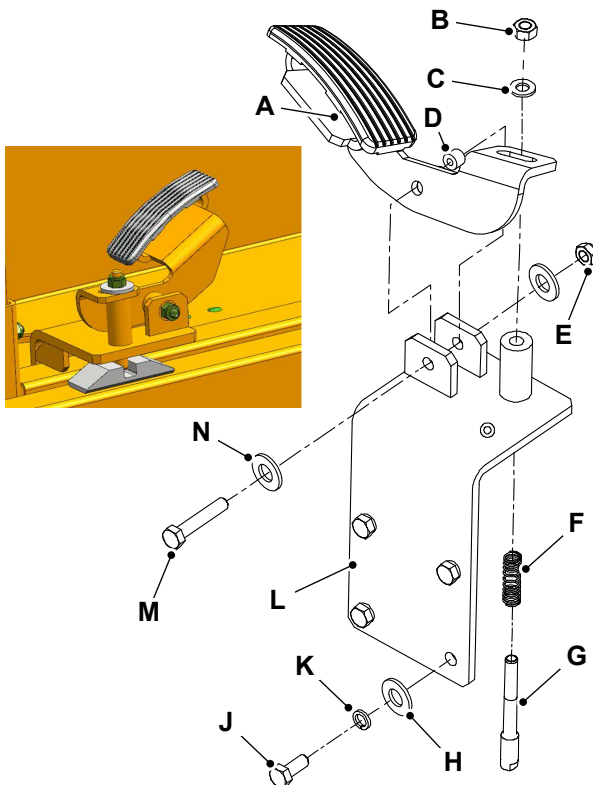
1. Make the machine safe with the platform lowered.  
Refer to: [PIL 01-03-27](#).
2. Remove the nut 1 and washer 1.
3. Remove the nut 2, washer 3 (x2) and bolt 2.
4. Remove the pedal from the machine.
5. Collect the boss.
6. Remove the bolt 1 (x4), spring washer (x4) and washer 2 (4).
7. Remove the bracket from the machine.
8. Collect the spring and pin.

- L** Bracket
- M** Bolt 2
- N** Washer 3 (x2)

### Install

1. The installation procedure is the opposite of the removal procedure.

**Figure 96.**



- A** Pedal
- B** Nut 1
- C** Washer 1
- D** Boss
- E** Nut 2
- F** Spring
- G** Pin
- H** Washer 2 (x4)
- J** Bolt 1 (x4)
- K** Spring washer (x4)

## 50 - Wear Pads

### Remove and Install

It is recommended that the wear pads are replaced in complete sets.

#### Remove

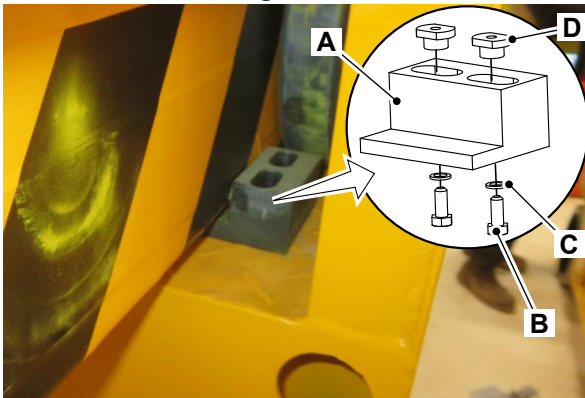
1. Make the machine safe with the platform lowered.

Refer to: [PIL 01-03-27](#).

2. Remove the front wear pads.

- 2.1. Remove the setscrew (x4) from the front wear pads (x2).

**Figure 97.**



- A** Front wear pads
- B** Setscrew (x2)
- C** Washer (x2)
- D** Wear pad nut (x2)

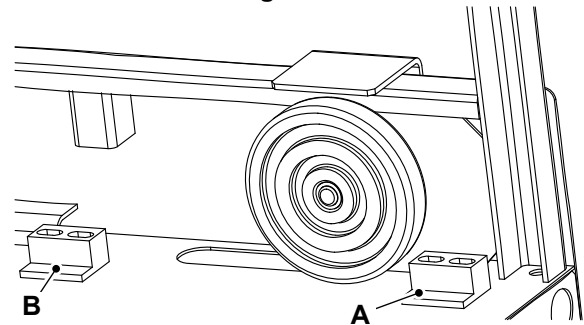
3. Remove the rear wear pads.

- 3.1. Remove the platform extension from the platform.

Refer to: [Remove and Install \(PIL 06-97-03\)](#).

- 3.2. Remove the setscrews (x4) from the rear wear pads (x2).

**Figure 98.**



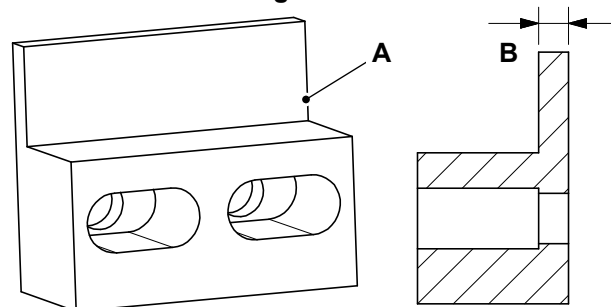
- A** Front wear pads
- C** Rear wear pads

4. Examine the pads for wear, cracks or damage. Replace as necessary.

5. Make sure that wear is within the specified limits. Dimension: 3mm

- 5.1. The original dimensions (as of new) are shown. Refer to [Figure 99](#).

**Figure 99.**



- A** Wear pad
- B** Thickness (6mm)

#### Install

1. The installation procedure is the opposite of the removal procedure.



---

Notes:

---

---

---

---

---

---

---

---

---

---

---



---

# 24 - Brake System

Contents	Page No.
Acronyms Glossary .....	24-2
24-00 Brake System	
24-00-00 General .....	24-3

JCB © CONNOR STANMORE - 13/03/2026 07:57.



---

## Acronyms Glossary

LED      Light Emitting Diode



## 00 - Brake System

### 00 - General

Introduction .....	24-3
Health and Safety .....	24-4
Operation .....	24-5
Check (Operation) .....	24-11
Disassemble and Assemble .....	24-12

### Introduction

This machine has park brake installed on the front wheels only.

The park brake will release automatically during travel, the brake will not release during lifting.

JCB © CONNOR STANMORE - 13/03/2026 07:57.

## Health and Safety

### Working Under the Machine

Make the machine safe. Make sure the park brake is engaged and machine is fully isolated. Remove the machine key switch, disconnect the battery. Use blocks to prevent unintentional movement of the wheels.

### Springs

Always wear personal protective equipment when dismantling assemblies containing components under pressure from springs. This will protect against eye injury from components accidentally flying out.

**WARNING!** Before working on the brake system, make sure that the machine is on solid level ground. Put blocks on all wheels to prevent the machine rolling.

**WARNING!** Before testing the park brake make sure the area around the machine is clear of people.

**WARNING!** Do not use a machine with a faulty park brake.

**WARNING!** Do not use the machine with any part of its brake system disconnected or inoperative. When the test has been completed, make sure all brake system components are installed and the system is operating correctly.

## Operation

For: S1932E EDRV [RAJ], S2632E EDRV [RAJ], S2646E EDRV [RAJ], S3246E EDRV [RAJ], S4046E EDRV [RAJ], S4550E EDRV [RAJ], Manual Release ..... Page 24-5

For: S1932E EDRV [RAJ], S2632E EDRV [RAJ], S2646E EDRV [RAJ], S3246E EDRV [RAJ], S4046E EDRV [RAJ], S4550E EDRV [RAJ], Electric Release ..... Page 24-8

(For: S1932E EDRV [RAJ], S2632E EDRV [RAJ], S2646E EDRV [RAJ], S3246E EDRV [RAJ], S4046E EDRV [RAJ], S4550E EDRV [RAJ], Manual Release)

**▲ WARNING** Do not use the platform controller to release the platform when it is stuck, snagged or caught. In this case, use the ground controller only when there are no persons on the platform.

**Notice:** Following any incident, thoroughly inspect the machine. Do not raise the platform until you are sure that all damage has been repaired and that all controls are operating correctly. Test all functions first from the ground controller, then from the platform controller.

If the machine becomes disabled, the machine must be made safe, lifted onto a transporter and moved to a location where it can be repaired.

Towing, winching or pushing the machine without following the correct procedure will damage parts of the machine. If possible, repair the disabled machine where it stands.

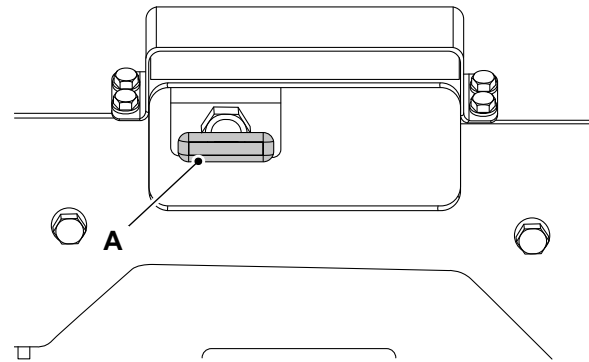
### Lower the Platform (Emergency Operation)

The lowering alarm does not sound while lowering but if the machine is switched ON, the fault alarm will sound due to lowering without electrical controls. Lowering may continue.

To lower the platform in emergency conditions:

1. Pull out the emergency lowering lever. Refer to Figure 100.
2. Release the lever to stop the operation.

Figure 100.



A Emergency lowering lever

### Manual Brake Release (for S1932E EDRV)

**▲ WARNING** Make the machine safe. Make sure the park brake is engaged. Use wheel chocks to prevent unintentional movement of the wheels.

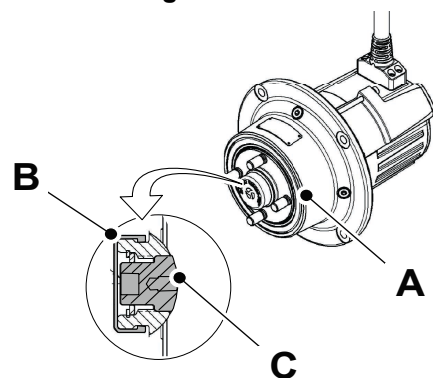
1. The manual brake release system is located in the front wheels of the machine.
2. Remove the rubber cap.
3. Use a 3/8" square drive to turn the brake release cap counterclockwise to disconnect.
4. Turn the brake release cap clockwise to reconnect after the machine is recovered to reapply the brakes.

- 4.1. Tighten it to the specified torque value.

Torque: 40–68N·m

5. Install the rubber cap again.

Figure 101.

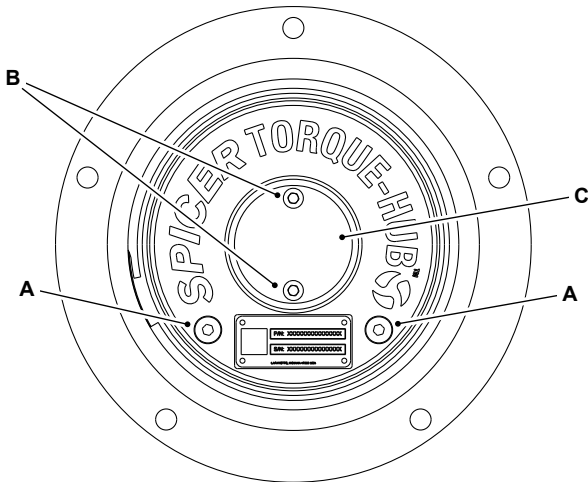


A Wheel motor  
B Rubber cap  
C Brake release cap

**Manual Brake Release (for S2632E EDRV, S2646E EDRV, S3246E EDRV, S4046E EDRV, S4550E EDRV)**

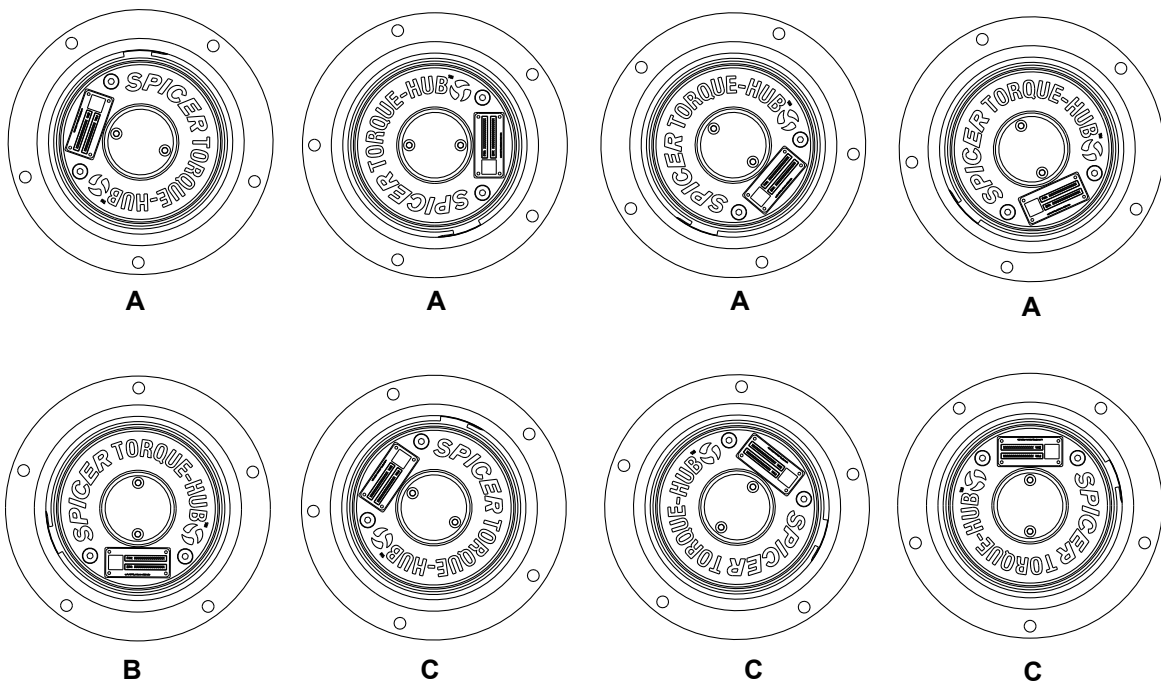
The brakes are designed to be engaged when the machine is not running. To manually release the brake, if the machine is disabled, the sun gears must be removed which are located in the front wheel motors.

**Figure 102. Component Identification**



- A Oil plug (x2)
- B Capscrew (x2)
- C Cover cap

**Figure 103. Oil plug positions with respect to the bottom of the cover cap**



A Scenario-1

B Scenario-2

When the machine is unable to move, there are three possible positions of the oil plugs with respect to the bottom of the cover cap:

- One oil plug is below the bottom of the cover cap and the other oil plug is above the bottom of cover cap.
- Both oil plugs are below the bottom of the cover cap.
- Both oil plugs are above the bottom of the cover cap.

The procedure to drain oil and remove the sun gear varies slightly as per the three possible positions.

### C Scenario-3

#### Before Starting the Procedure

**▲ WARNING** Make sure wheel chocks are installed to the wheels before releasing the park brake, otherwise the machine could roll away.

**WARNING** Take care when disconnecting hydraulic hoses and fittings as the oil will be hot.

1. Make the machine safe.  
Refer to: [Introduction \(PIL 01-03-27\)](#).

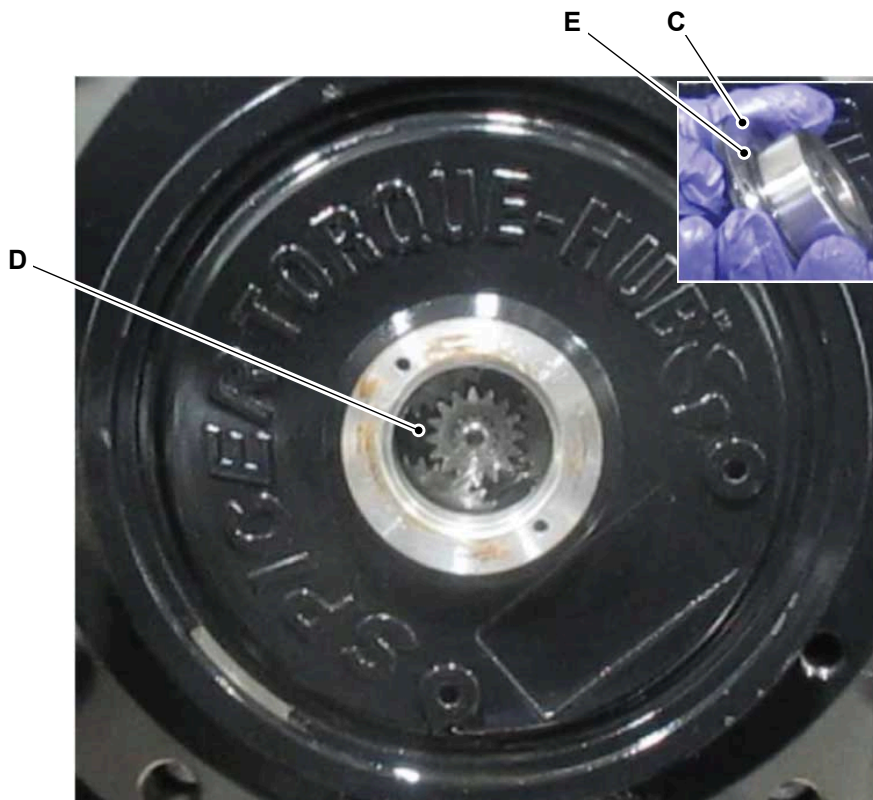
2. Allow the machine to cool.

#### Scenario-1

1. Remove the upper oil plug.
2. Remove the lower drain plug and drain the oil into a container.
  - 2.1. Measure the oil removed if it is not necessary to perform a complete oil change.
3. Install the oil plugs and tighten it to specified torque value.  
Torque: 14.6–16.2N·m

4. Use a 2.5mm hex wrench to remove the capscrew (x2). Refer to [Figure 102](#).
5. Remove the cover cap.
  - 5.1. The O-ring should remain within the cover cap. Refer to [Figure 104](#).
6. Use a magnet or plastic pliers to remove the sun gear from the gearbox.
  - 6.1. As the gearbox may be under some load, you may need to move the machine backward or forward to free the sun gear.
7. After the sun gear is removed, the unit will be in freewheel state.
8. Install the cover cap along with the O-ring and tighten the capscrew (x2) to the specified torque value. Refer to [Figure 102](#).  
Torque: 2.8–3.4N·m
9. Repeat steps 1 to 8 for the other wheel of the machine.
10. The machine can now be towed or pushed as required.

Figure 104.



- C** Magnet  
**E** O-ring

### Scenario-2

In this case, remove both oil plugs at the bottom to drain the oil and continue with the rest of the steps of scenario 1.

### Scenario-3

1. Remove the upper most oil plug to remove any pressure.
2. Use a 2.5mm hex wrench to remove the capscrew (x2).
3. Remove the cover cap and the drain oil into a container.
  - 3.1. Measure the oil removed if it is not necessary to perform a complete oil change.
4. Install the oil plug and tighten to the specified torque value.  
 Torque: 14.6–16.2N·m
5. Use a magnet or plastic pliers to remove sun gear from gearbox.
  - 5.1. As the gearbox may be under some load, you may need to move the machine backward or forward to free the sun gear.
6. After the sun gear is removed, the unit will be in freewheel state.
7. Install the cover cap along with the O-ring and tighten the capscrew (x2) to the specified torque value.  
 Torque: 2.8–3.4N·m
8. Repeat steps 1 to 7 for the other wheel of the machine.
9. The machine can now be towed or pushed as required.

### Re-engaging the Brakes

Either replace the same amount of oil removed or drain all oil out before re-installation of the sun gear for complete oil change. If you are re-using the removed oil, skip to step 2.

1. While still in freewheel mode, position one of the oil plugs to lower most position and drain the oil into a container.
2. While still in freewheel mode position both the plugs to the top most position.

### D Sun gear

3. Remove cover cap.
4. Use a magnet to install the sun gear into the gear mesh.
  - 4.1. If required, move the machine backward and forward to allow the splines and gear teeth to align with the sun gear.
  - 4.2. Once the sun gear is installed, the machine will not freewheel.
5. Install the cover cap along with O-ring and tighten the capscrew (x2) to the specified torque value.  
 Torque: 2.8–3.4N·m
6. Remove both the oil plugs.
7. Refill the same amount of oil removed previously or for complete oil drain, refill with the specified quantity of the approved oil.  
 Volume: 0.3L
8. Install both the oil plugs and tighten to the specified torque value.  
 Torque: 14.6–16.2N·m
9. Repeat steps 1 to 8 for the other wheel of the machine.

(For: S1932E EDRV [RAJ], S2632E EDRV [RAJ], S2646E EDRV [RAJ], S3246E EDRV [RAJ], S4046E EDRV [RAJ], S4550E EDRV [RAJ], Electric Release)

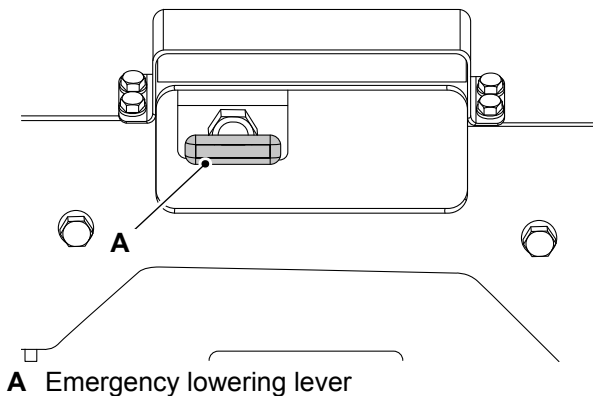
### Lower the Platform (Emergency Operation)

The lowering alarm does not sound while lowering but if the machine is switched on the fault alarm will sound due to lowering without electrical controls. Lowering may continue.

To lower the platform in emergency conditions:

1. Pull out the emergency lowering lever. [Refer to Figure 105.](#)
2. Release the lever to stop the operation.

Figure 105.



A Emergency lowering lever

### Electric Brake Release (Through Platform Controller Menu)

**▲ WARNING** Do not use the platform controller to release the platform when it is stuck, snagged or caught. In this case, use the ground controller only when there are no persons on the platform.

**Notice:** Following any incident, thoroughly inspect the machine. Do not raise the platform until you are sure that all damage has been repaired and that all controls are operating correctly. Test all functions first from the ground controller, then from the platform controller.

**WARNING** Make the machine safe. Make sure the park brake is engaged. Use wheel chocks to prevent unintentional movement of the wheels.

The brake can be released electrically in emergency situations by accessing the main menu as shown in the menu structure.

Refer to: [Calibrate \(PIL 33-24-05\)](#).

When the Brake Release mode is active, the chassis display will show the following screen flashing at a rate of 0.5s.

Figure 106.



Also, when the Brake Release mode is active, the chassis buzzer will beep for 0.5s, then mute for 1s, and repeat.

When the E-stop is pressed or the ignition switch is operated, the brakes will be engaged again.

### Electric Brake Release (Through Brake Release Switch, If Fitted)

**▲ WARNING** Make the machine safe. Make sure the park brake is engaged. Use wheel chocks to prevent unintentional movement of the wheels.

For model specific brake release switch illustrations, Refer to: [Introduction \(PIL 01-09-15\)](#).

The brake can be released electrically by accessing the brake release switch inside the RH door.

Refer to: [Introduction \(PIL 01-09-15\)](#).

1. Make the machine safe with the platform lowered.

Refer to: [PIL 01-03-27](#).

2. Put the machine in the chassis control mode.

Refer to: [Operation \(PIL 01-12-00\)](#).

3. Open the RH door.

4. To release the brake, press and hold the brake release switch for more than the specified duration, and an alarm will sound.

Duration: 3s

5. When brake release is active, 'BRK RELS' will flash on the base display.

When the Brake Release mode is active, the chassis display will show the screen flashing at a rate of 0.5s. Also, the chassis buzzer will beep for 0.5s, then mute for 1s, and repeat.

When the E-stop is pressed or the ignition switch is operated, the brakes will be engaged again.

### Service Mode

The service mode is only intended for use by an authorised and trained service engineers. It is not required for normal machine operation.

In addition to the entry from joystick, service mode can also be entered through base.

Follow the below steps for base entry:

1. Make sure that machine software must be version A115 or above and joystick firmware version must be 00.00.30.

2. Turn the key switch to the chassis position.

3. Press and hold enable key till amber LED (Light Emitting Diode) starts blinking (approx 11 sec).

4. Turn the ignition key to the OFF position within specified time.

Duration: 5s



5. Turn ON the ignition key at chassis side.
6. Make sure that the chassis display will show the screen "SER INPROG" (service mode active).

**Live Value Display**

Make sure that machine software must be version A115 or above and joystick firmware version must be 00.00.30.

1. Enter the service mode with either platform or base mode.
2. After performing a key cycle, make sure that the key switch is set to the chassis position.
3. Use lift/lower toggle to scroll through the values.
  - 3.1. Values can be seen in base display during service mode. [Refer to Table 41.](#)

**Table 41.**

Name	Value Type	Display Format
Angle sensor voltage	Millivolts	AS xxx
Pressure sensor 1 voltage	Millivolts	P1 xxx
Pressure sensor 2 voltage	Millivolts	P2 xxx
Limit switches	<Digit1><Digit2><Digit3> Range: 000 - 111	LM xxx
Digit 1 - Lower limit switch NC	0= Switch OFF	
Digit 2 - Lower limit switch NO	1= Switch ON	
Digit 3 - Upper limit switch NC		
Pothole guard switches	<Digit1><Digit2><Digit3> Range: 000 - 111	PH xxx
Digit 1 - Left pothole switch NO	0= Switch OFF	
Digit 2 - Right pothole switch NO	1= Switch ON	
Digit 3 - Left-right pothole series		
Chassis control switches	<Digit1><Digit2><Digit3> Range: 000 - 111	CH xxx
Digit 1 - Base enable switch	0= Switch OFF	
Digit 2 - Base raise switch	1= Switch ON	
Digit 3 - Base lower switch		
Tilt switch	ON: Within Inclination Limit OFF: Out of Inclination Limit	TL xxx
Raise/Lower solenoids	<Digit1><Digit2><Digit3> Range: 000 - 111	RL xx
Digit 1- Raise solenoid	0= Switch OFF	
Digit 2- Lower solenoid	1= Switch ON	
DC contactor coil	ON/OFF	DC xxx
Battery voltage	Volts	BV xxx

JCB © CONNOR STANMORE - 13/03/2026 07:57.

## Check (Operation)

The brakes must be able to hold the machine on any slope it is able to climb. Refer to operators manual.

Make a note of the following.

- You must check the brakes for correct operation at regular intervals. Refer to Maintenance Schedules.
- The correct brake function is necessary for safe machine operation.
- The brake function must operate smoothly, free of hesitation, jerking and unusual noise.
- Do this procedure with the machine on a firm, level surface that is free of obstructions.

1. Make the machine safe with the platform lowered.

[Refer to: PIL 01-03-27.](#)

2. Make sure that the platform extension is in the fully retracted position.

3. Put a mark on the ground to use as a test line.

4. Turn the ignition switch to platform control.

5. Pull out the ground emergency stop button to the ON position.

6. Pull out the platform emergency stop button to the ON position.

7. Make a note of the point on the machine (contact patch of a tyre) as a visual reference when you cross the test line.

8. Press the drive function button.

9. Press and hold the drive/steer function enable switch on the control handle.

10. Move the control lever in the forward direction.

11. Bring the machine to top drive speed before you reach the test line.

12. Release the control lever when the selected reference point on the machine crosses the test line.

13. Measure the distance between the test line and the machine reference point.

14. Make sure that the braking distance is within the specified limits.

[Refer to: PIL 01-48.](#)

15. Raise the platform.

16. Do the steps 3 to 13 with the platform raised.

17. Make sure that the braking distance is within the specified limits.

[Refer to: PIL 01-48.](#)



## **Disassemble and Assemble**

This is a non-serviceable part, replace the complete assembly.



---

# 25 - Steering System

## Contents

## Page No.

25-00 Steering System	
25-00-00 General .....	25-2

JCB © CONNOR STANMORE - 13/03/2026 07:57.



## 00 - Steering System

### 00 - General

Introduction .....	25-2
Component Identification .....	25-3
Operation .....	25-4
Lubricate .....	25-5

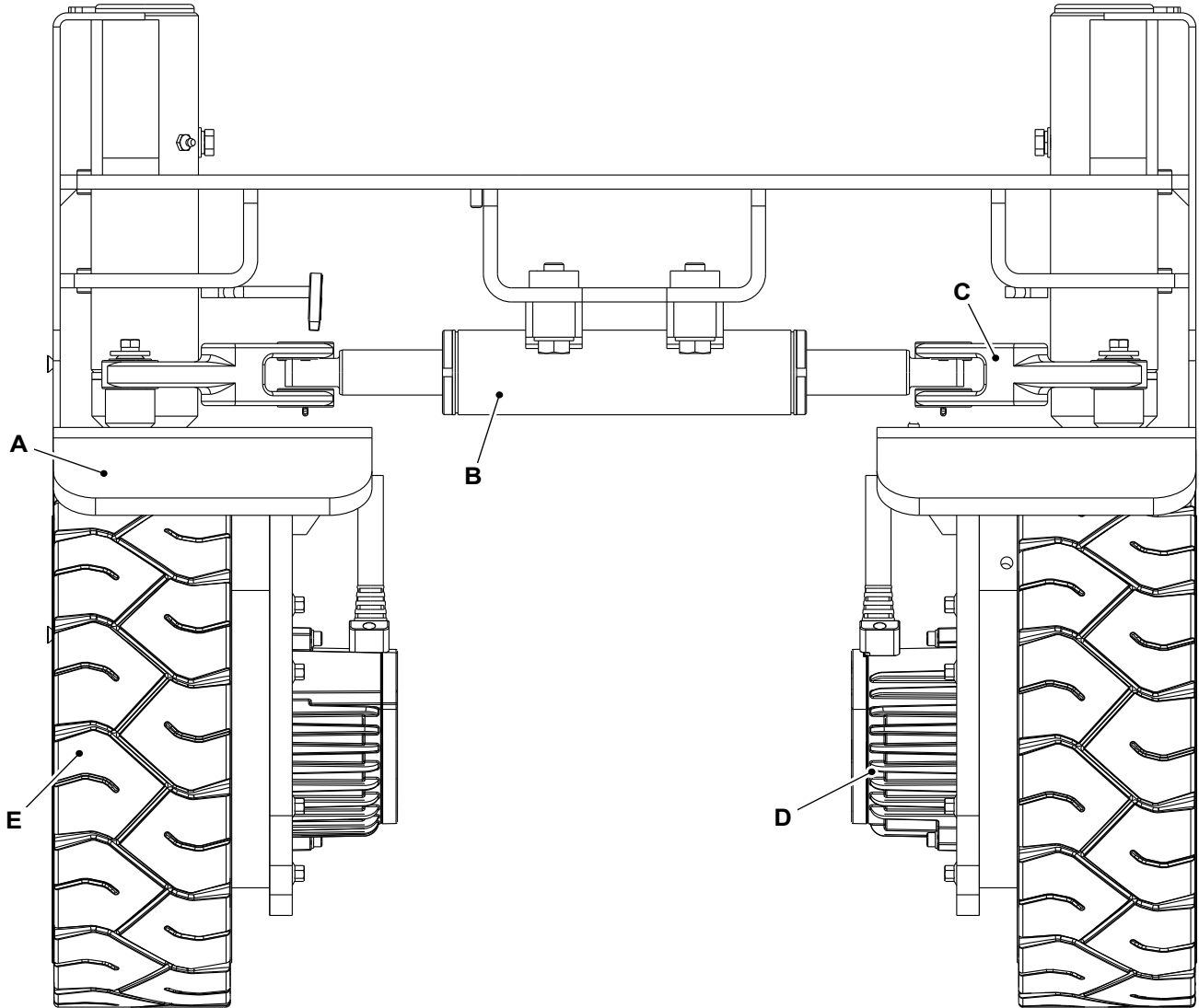
### Introduction

The steering is controlled by the hydraulic system and the main hydraulic pump through the control valve block. There is a double acting double end steering ram. The ram drives the action of a connecting rod and the spindle rotates to achieve the steering action.

JCB © CONNOR STANMORE - 13/03/2026 07:57.

**Component Identification**

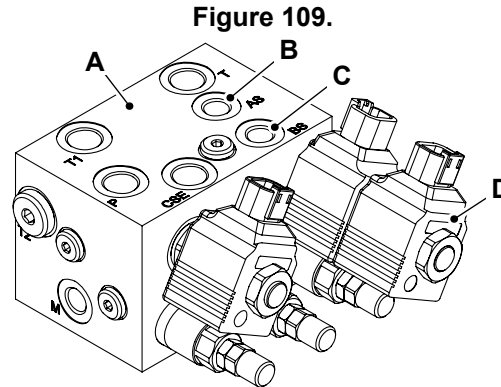
**Figure 107.**



- A** Wheel carrier
- C** Connecting rod
- E** Wheel

- B** Steering cylinder ram
- D** Wheel drive motor

## Operation



**A** Control valve  
**C** Port - steer to right

**B** Port - steer to left  
**D** Steering solenoid

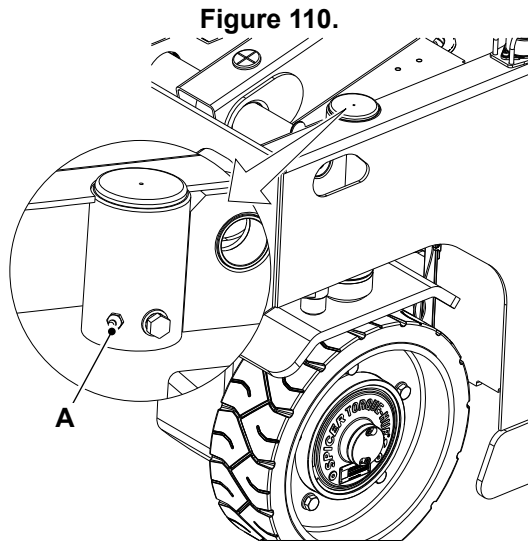
You must read the following description with reference to the hydraulic schematic circuit diagram.  
[Refer to: Diagram \(PIL 30-00-50\).](#)

When right steering button is pressed, the pressurised oil flows through steering solenoid valve into the left cavity (port 'AS') of the steering cylinder ram and the oil in the right cavity of steering cylinder flows into the tank through the steering solenoid valve.

When left steering button is pressed, the pressurised oil flows through steering solenoid valve into the right cavity (port 'BS') of the steering cylinder ram and the oil in the left cavity of steering cylinder flows into the tank through the steering solenoid valve.

## Lubricate

There is one grease point for each wheel pivot. Refer to [Figure 110](#).



A Grease point



---

Notes:

---

---

---

---

---

---

---

---

---

---

---

---

---

---

---

---

---

---

---

---

---

---

---

---



---

## 27 - Driveline

Contents	Page No.
Acronyms Glossary .....	27-2
27-00 Driveline	
27-00-00 General .....	27-3
27-27 Hub	
27-27-00 General .....	27-4
27-29 Wheel	
27-29-00 General .....	27-7
27-32 Wheel Drive Motor	
27-32-00 General .....	27-12
27-33 Tyre	
27-33-00 General .....	27-19



---

## Acronyms Glossary

RMS	Root Mean Square
RPM	Revolutions Per Minute

## 00 - Driveline

### 00 - General

#### Introduction

The driveline system installed on this machine is an electrically operated and driven system. It consists of the following components:

- Wheel drive motor.  
[Refer to: PIL 27-32-00.](#)
- Wheel.  
[Refer to: PIL 27-29-00.](#)
- Tyre.  
[Refer to: PIL 27-33-00.](#)

## 27 - Hub

### 00 - General

Component Identification ..... 27-4  
Remove and Install ..... 27-5

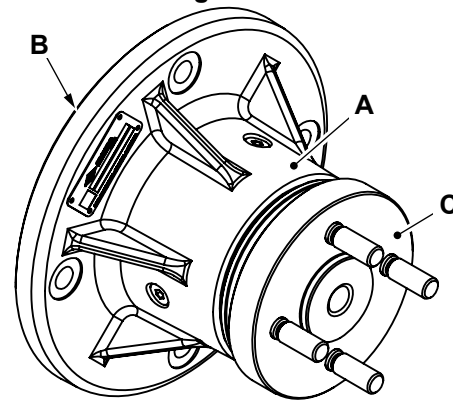
### Component Identification

For: S1932E EDRV [RAJ] ..... Page 27-4

For: S2632E EDRV [RAJ], S2646E EDRV [RAJ], S3246E EDRV [RAJ], S4046E EDRV [RAJ], S4550E EDRV [RAJ] ..... Page 27-4

(For: S1932E EDRV [RAJ])

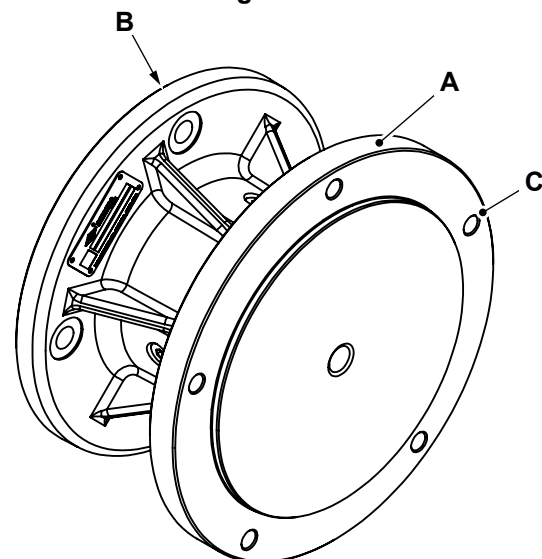
Figure 112.



- A Wheel hub
- B Frame mounting face
- C Wheel mounting face

(For: S2632E EDRV [RAJ], S2646E EDRV [RAJ], S3246E EDRV [RAJ], S4046E EDRV [RAJ], S4550E EDRV [RAJ])

Figure 113.



- A Wheel hub
- B Frame mounting face
- C Wheel mounting face

## Remove and Install

For: S1932E EDRV [RAJ] ..... Page 27-5

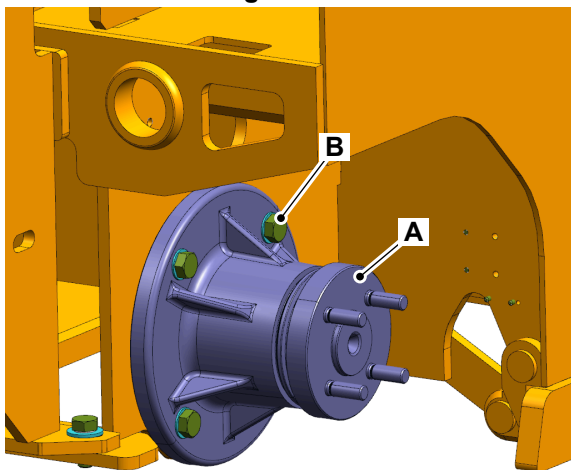
For: S2632E EDRV [RAJ], S2646E EDRV [RAJ], S3246E EDRV [RAJ], S4046E EDRV [RAJ], S4550E EDRV [RAJ] ..... Page 27-5

(For: S1932E EDRV [RAJ])

### Remove

1. Make the machine safe.  
Refer to: [PIL 01-03-27](#).
2. Remove the relevant rear wheel.  
Refer to: [PIL 27-29-00](#).
3. Remove the bolts (x4).
4. Remove the wheel hub.

**Figure 114.**



- A** Wheel hub
- B** Bolt (x4)

### Install

1. The installation procedure is the opposite of the removal procedure. Additionally do the following steps.
2. Tighten the bolts to the correct torque value.
  - 2.1. Make sure that you follow the symmetrical pattern for the tightening sequence.
3. Check the condition of wheel mounting studs, if necessary replace or tighten to the specified torque.  
Torque: 6.78–9.49N·m
  - 3.1. Use the specified tool for tightening the stud.

## Wheel Stud

### Install

1. Apply Loctite SF 7649 on the threads of the stud (x4).
2. Apply Loctite 243 to the same threads on the stud (x4) and to the spindle thread holes.
3. Install the stud (x4) in the spindle thread holes.
4. Tighten the studs to the specified torque.  
Torque: 6.78–9.49N·m

**Table 41. Torque Values**

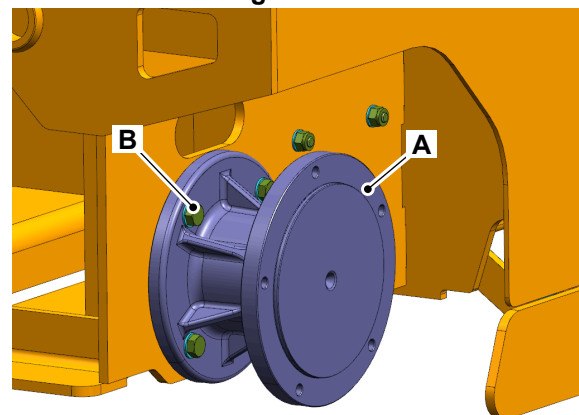
Item	Nm
B	110

(For: S2632E EDRV [RAJ], S2646E EDRV [RAJ], S3246E EDRV [RAJ], S4046E EDRV [RAJ], S4550E EDRV [RAJ])

### Remove

1. Make the machine safe.  
Refer to: [PIL 01-03-27](#).
2. Remove the relevant rear wheel.  
Refer to: [Remove and Install \(PIL 27-29-00\)](#).
3. Remove the bolts (x4).
4. Remove the wheel hub.

**Figure 115.**



- A** Wheel hub
- B** Bolt (x4)

### Install

1. The installation procedure is the opposite of the removal procedure. Additionally do the following steps.
2. Tighten the bolts to the correct torque value.



2.1. Make sure that you follow the symmetrical pattern for the tightening sequence.

**Table 41. Torque Values**

<b>Item</b>	<b>Nm</b>
B	110

## 29 - Wheel

### 00 - General

Introduction .....	27-7
Health and Safety .....	27-8
Technical Data .....	27-8
Check (Condition) .....	27-9
Remove and Install .....	27-9

### Introduction

The machine uses solid tyres, which do not need inflating. The wheel and tyre assemblies are complete units, if damaged they must be replaced as a complete assembly.

Refer to: [Health and Safety \(PIL 27-29-00\)](#).

Make sure that the tyres are kept in good condition.

Refer to: [Check \(Condition\) \(PIL 27-29-00\)](#).

## Health and Safety

▲ **WARNING** Do not install pneumatic tyres on a wheel made for a solid tyre. Do not install a solid tyre on a wheel made for a pneumatic tyre. If you are unsure of the correct specification for your machine, contact your local JCB dealer or a trained specialist.

**WARNING** Wheels and tyres are heavy. Take care when lifting or moving them. Store with care to ensure that they cannot fall and cause injury. Use suitable lifting equipment if necessary.

## Technical Data

**Table 42.**

Wheel Nut Torque	380–460N·m
------------------	------------

## Check (Condition)

Always drive with consideration for the condition of the tyres. Check the tyres daily for the signs of damage and wear. For example:

- Signs of distortion
- Cuts
- Embedded objects (nails, etc.)
- Continuous tread
- Edge damage
- Uneven wear
- Compare wear between tyres

Never modify tyres or install tyres which are not intended for use on this machine. Contact you local JCB dealer to replace the parts.

## Remove and Install

For: S1932E EDRV [RAJ] ..... Page 27-9

For: S2632E EDRV [RAJ], S2646E EDRV [RAJ], S3246E EDRV [RAJ], S4046E EDRV [RAJ], S4550E EDRV [RAJ] ..... Page 27-10

(For: S1932E EDRV [RAJ])

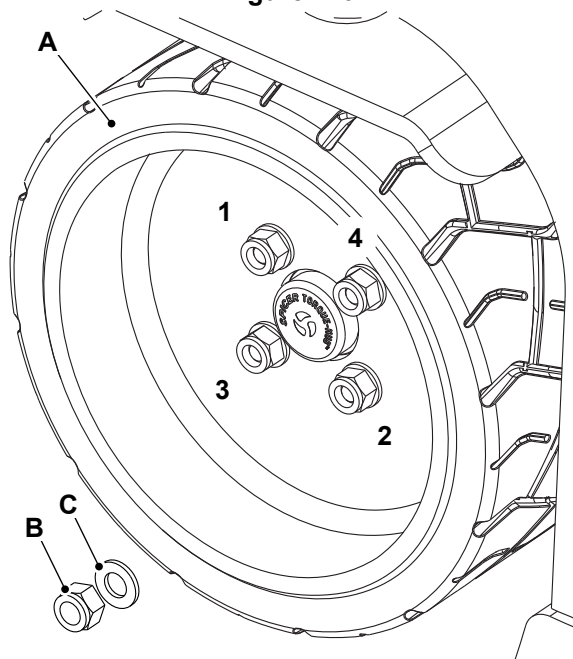
### Special Tools

Description	Part No.	Qty.
Wheel Chock - JC/405217		6
Forklift Jack	334/F1285	1

**▲ CAUTION** This component is heavy. It must only be removed or handled using a suitable lifting method and device.

### Remove

1. Make the machine safe.  
[Refer to: PIL 01-03-27.](#)
2. Disconnect the battery quick disconnect handle.  
[Refer to: Disconnect and Connect \(PIL 33-05-00\).](#)
3. Chock all wheels except the one to be removed.  
[Special Tool: Wheel Chock - JC/405217 \(Qty.: 6\)](#)
4. Loosen the wheel nut (x4) in the sequence shown. [Refer to Figure 116.](#)

**Figure 116.**


- A** Wheel
- B** Wheel nut (x4)
- C** Washer (x4)

5. Use a suitable Jack to raise the machine at the end of the required wheel.  
**Special Tool: Forklift Jack (Qty.: 1)**
6. Remove the wheel nut (x4) and washer (x4).
7. Support the wheel with suitable lifting equipment.
8. Remove the wheel from the hub.

### Install

1. The installation procedure is the opposite of the removal procedure. Additionally do the following steps.
2. Tighten the wheel nut (x4) in the sequence shown to the specified torque value. **Refer to Figure 116.**

Torque: 123N·m

(For: S2632E EDRV [RAJ], S2646E EDRV [RAJ], S3246E EDRV [RAJ], S4046E EDRV [RAJ], S4550E EDRV [RAJ])

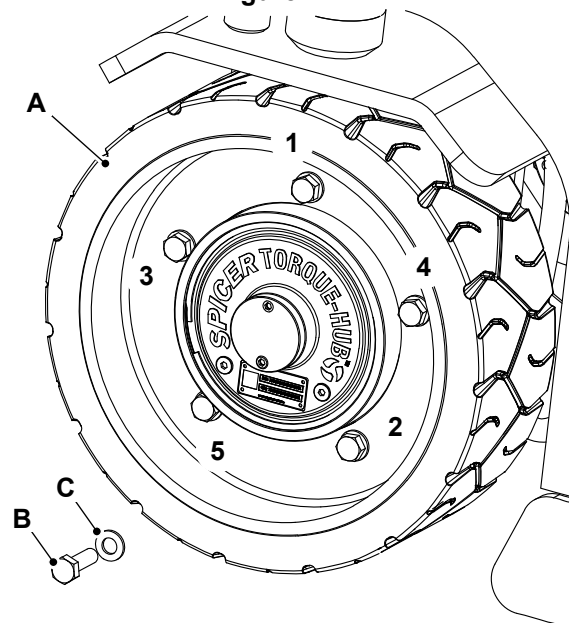
### Special Tools

Description	Part No.	Qty.
<a href="#">Wheel Chock - JC/405217</a>		6
<a href="#">Forklift Jack</a>	<a href="#">334/F1285</a>	1

**▲ CAUTION** This component is heavy. It must only be removed or handled using a suitable lifting method and device.

### Remove

1. Make the machine safe.  
**Refer to: PIL 01-03-27.**
2. Disconnect the battery quick disconnect handle.  
**Refer to: Disconnect and Connect (PIL 33-05-00).**
3. Chock all wheels except the one to be removed.  
**Special Tool: Wheel Chock - JC/405217 (Qty.: 6)**
4. Loosen the wheel bolt (x5) in the sequence shown. **Refer to Figure 117.**

**Figure 117.**


- A** Wheel
- B** Wheel bolt (x5)
- C** Washer (x5)

5. Use a suitable Jack to raise the machine at the end of the required wheel.  
**Special Tool: Forklift Jack (Qty.: 1)**
6. Remove the wheel bolt (x5) and washer (x5).
7. Support the wheel with suitable lifting equipment.
8. Remove the wheel from the hub.

### Install

1. The installation procedure is the opposite of the removal procedure. Additionally do the following steps.

2. Tighten the wheel bolt (x5) in the sequence shown to the specified torque value. [Refer to Figure 117.](#)

Torque: 123N·m



## 32 - Wheel Drive Motor

### 00 - General

Introduction .....	27-12
Technical Data .....	27-13
Component Identification .....	27-13
Drain and Fill .....	27-15
Remove and Install .....	27-17

### Introduction

The wheel drive motor installed on these machines is AC Wheel Drive motor.

JCB © CONNOR STANMORE - 13/03/2026 07:57.

## Technical Data

Table 43. Electric Motor Data

Description	Data
Input voltage	24V DC
Maximum speed	5000 RPM (Revolutions Per Minute)
Maximum torque	20N·m @ 200A RMS (Root Mean Square)

Table 44. Input Parking Brake

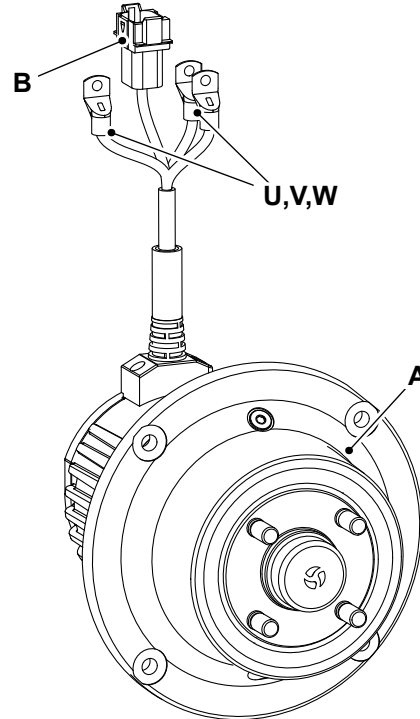
Description	Data		
	S1932 EDRV	S2632 EDRV	S3246 EDRV
Input voltage	24V DC		
Maximum speed	5000 RPM	5400 RPM	
Maximum torque	20N·m @ 200A RMS	30N·m @ 200A RMS	

Table 45. Input Parking Brake

Description	Data		
	S1932 EDRV	S2632 EDRV	S3246 EDRV
Release voltage	24 ± 2.4V DC		
Minimum static torque rating	20N·m	30N·m	
Nominal coil resistance	17–22Ω		
Holding voltage	12–18V DC	16V DC	

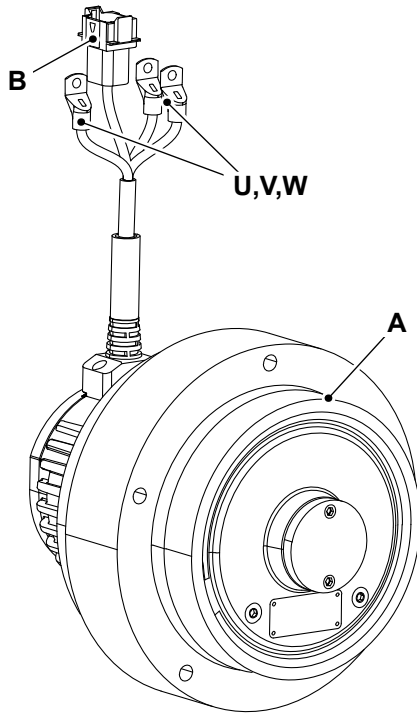
## Component Identification

Figure 120. Component Identification of Wheel Drive Motor(S1932E EDRV)



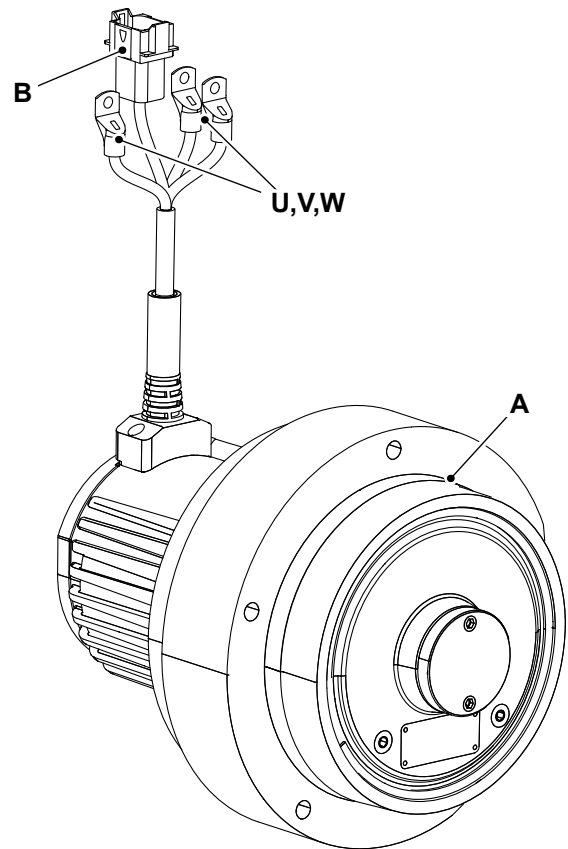
- A** Motor
- B** Sensor Connector
- U** Terminal (Green)
- V** Terminal (Black)
- W** Terminal (White)

**Figure 121. Component Identification of Wheel Drive Motor (S2632E EDRV)**



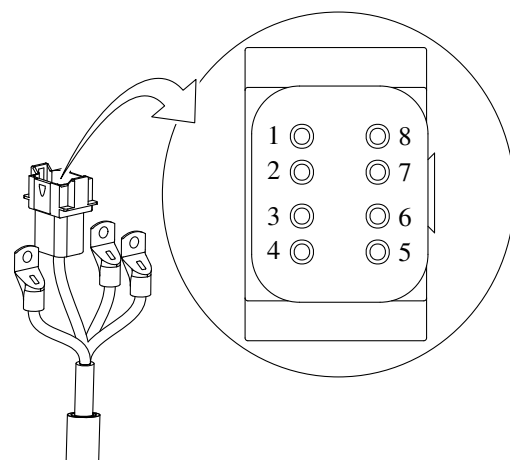
- A** Motor
- B** Sensor Connector
- U** Terminal (Green)
- V** Terminal (Black)
- W** Terminal (White)

**Figure 122. Component Identification of Wheel Drive Motor (S2646E EDRV, S3246E EDRV, S4046E EDRV, S4550E EDRV)**



- A** Motor
- B** Sensor Connector
- U** Terminal (Green)
- V** Terminal (Black)
- W** Terminal (White)

**Figure 123. Sensor connector pin out for encoder**



JCB © CONNOR STANMORE - 13/03/2026 07:57.

**Table 46.**

<b>Connecting instruction for Encoder, Temp sensor, and Brake</b>		
<b>Connector part number</b>	<b>Pin number</b>	<b>Description</b>
DT04-08PA	1	Encoder +5V
	2	Signal A(sin)
	3	Signal B (cos)
	4	Ground Shield
	5	Temperature +5V
	6	Not connected
	7	Brake +24V
	8	Brake ground

## Drain and Fill

For: S1932E EDRV [RAJ] ..... Page 27-15

For: S2632E EDRV [RAJ], S2646E EDRV [RAJ], S3246E EDRV [RAJ], S4046E EDRV [RAJ], S4550E EDRV [RAJ] ..... Page 27-16

(For: S1932E EDRV [RAJ])

**▲ CAUTION** It is illegal to pollute drains, sewers or the ground. Clean up all spilt fluids and/or lubricants.

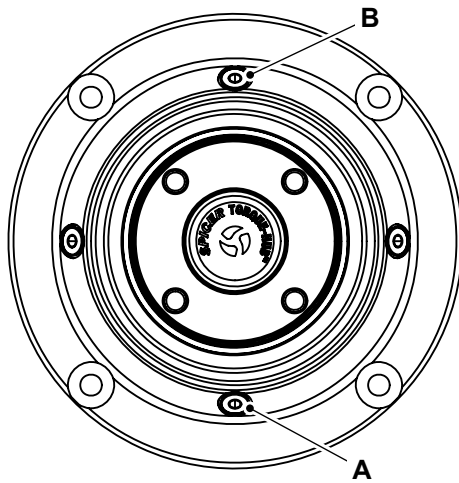
Used fluids and/or lubricants, filters and contaminated materials must be disposed of in accordance with local regulations. Use authorised waste disposal sites.

**CAUTION** Oil will gush from the hole when the drain plug is removed. Keep to one side when you remove the plug.

### Drain

1. Make the machine safe.  
[Refer to: PIL 01-03-27.](#)
2. Disconnect the battery quick disconnect handle.  
[Refer to: Disconnect and Connect \(PIL 33-05-00\).](#)
3. Remove the relevant wheel.  
[Refer to: Remove and Install \(PIL 27-29-00\).](#)
4. Position the hub as shown. [Refer to Figure 124.](#)
5. Remove the oil plugs at 6 o'clock and 12 o'clock position with 5mm hex wrench. [Refer to Figure 124.](#)
  - 5.1. Oil will drain through the 6 o'clock port and 12 o'clock port is a vent.
6. Drain the oil into a container. Contamination is removed more effectively when the oil is warm.

Figure 124.

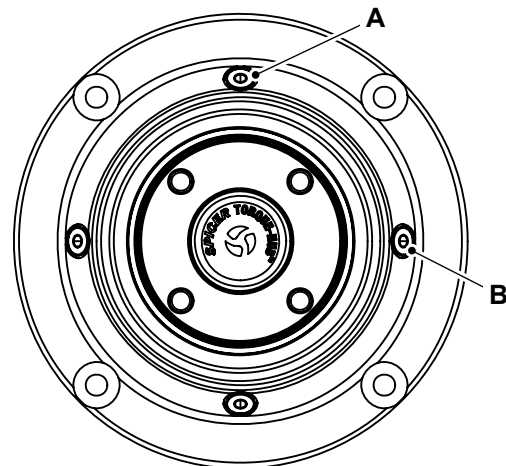


- A Oil plug (drain)
- B Oil plug (vent)

### Fill

1. Remove the oil plugs at 12 o'clock and 3 o'clock position with 5mm hex wrench. Refer to Figure 125.
2. Clean the oil plugs.
3. Check the condition of the seal. If necessary, replace.
4. Install the oil plug at 6 o'clock with seal, if removed to drain oil. Refer to Figure 124.
5. Fill with the correct oil through the 12 o'clock port until the oil starts to come out from the 3 o'clock port.
  - 5.1. Use ISO VG68 - 80W Gear oil.  
Volume: 0.15L
6. Install the oil plugs with seal.
7. Tighten the oil plugs to the specified torque.  
Torque: 6.7–9.5N·m

Figure 125.



- A Oil plug (fill)
- B Oil plug (level check)

(For: S2632E EDRV [RAJ], S2646E EDRV [RAJ], S3246E EDRV [RAJ], S4046E EDRV [RAJ], S4550E EDRV [RAJ])

**CAUTION** It is illegal to pollute drains, sewers or the ground. Clean up all spilt fluids and/or lubricants.

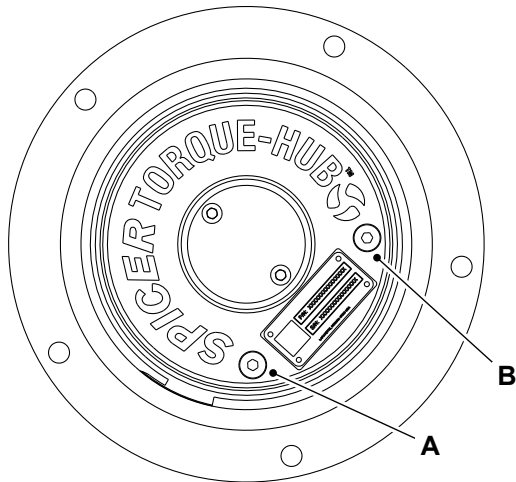
Used fluids and/or lubricants, filters and contaminated materials must be disposed of in accordance with local regulations. Use authorised waste disposal sites.

**CAUTION** Oil will gush from the hole when the drain plug is removed. Keep to one side when you remove the plug.

### Drain

1. Make the machine safe.  
Refer to: PIL 01-03-27.
2. Disconnect the battery quick disconnect handle.  
Refer to: Disconnect and Connect (PIL 33-05-00).
3. Remove the relevant wheel.  
Refer to: Remove and Install (PIL 27-29-00).
4. Position the hub as shown. Refer to Figure 126.
5. Remove the oil plugs with a 5mm hex wrench.
  - 5.1. Oil will drain through the bottom port and other port is a vent. Refer to Figure 126.
6. Drain the oil into a container. Contamination is removed more effectively when the oil is warm.

Figure 126.

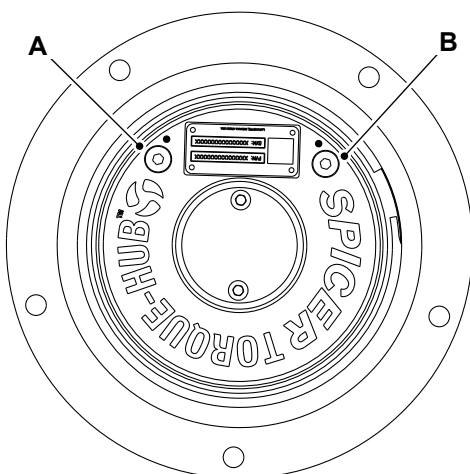


- A Oil plug (drain)
- B Oil plug (vent)

**Fill**

1. Position the hub as shown. [Refer to Figure 127.](#)
2. Refill with specified oil.
  - 2.1. Use ISO VG68 - 80W Gear oil  
Volume: 0.3L
3. Install both oil plugs and tighten to specified torque.  
Torque: 14.6–16.2N·m

Figure 127.



- A Oil plug (fill)
- B Oil plug (level check)

**Remove and Install**

For: S1932E EDRV [RAJ] ..... Page 27-17  
 For: S2632E EDRV [RAJ], S2646E EDRV [RAJ], S3246E EDRV [RAJ], S4046E EDRV [RAJ], S4550E EDRV [RAJ] ..... Page 27-18

(For: S1932E EDRV [RAJ])

**▲ WARNING** You could get killed or injured if you touch the Battery positive and Battery negative terminals of the motor controller. The controller is installed with energy storing devices (capacitors). You must discharge the controller before you remove or install.

**Remove**

1. Obey all electrical system health and safety information.  
[Refer to: Health and Safety \(PIL 33-00-00\).](#)
2. Make the machine safe.  
[Refer to: PIL 01-03-27.](#)
3. Disconnect the quick disconnect handle.  
[Refer to: Disconnect and Connect \(PIL 33-05-00\).](#)
4. Disconnect the batteries.  
[Refer to: Disconnect and Connect \(PIL 33-03-00\).](#)
5. Remove the relevant front wheel.  
[Refer to: Remove and Install \(PIL 27-29-00\).](#)
6. Disconnect the electrical terminals.
7. Remove the bolts (x4).
8. Remove the wheel drive motor.

**Install**

1. The installation procedure is the opposite of the removal procedure. Additionally do the following steps.
2. Tighten the bolts to the correct torque value.
  - 2.1. Make sure that you follow the symmetrical pattern for the tightening sequence.
3. Check the condition of wheel mounting studs, replace if necessary or tighten to the specified torque.  
Torque: 6.78–9.49N·m
  - 3.1. Use the specified tool for tightening the stud.

## Wheel Stud

### Install

1. Apply Loctite SF 7649 on the threads of the stud (x4).
2. Apply Loctite 243 to the same threads on the stud (x4) and to the spindle thread holes.
3. Install the stud (x4) in the spindle thread holes.
4. Tighten the studs to the specified torque.  
Torque: 6.78–9.49N·m

**Table 46. Torque Values**

Item	Nm
B	110

(For: S2632E EDRV [RAJ], S2646E EDRV [RAJ], S3246E EDRV [RAJ], S4046E EDRV [RAJ], S4550E EDRV [RAJ])

**⚠ WARNING** You could get killed or injured if you touch the Battery positive and Battery negative terminals of the motor controller. The controller is installed with energy storing devices (capacitors). You must discharge the controller before you remove or install.

### Remove

1. Obey all electrical system health and safety information.  
[Refer to: Health and Safety \(PIL 33-00-00\).](#)
2. Make the machine safe.  
[Refer to: PIL 01-03-27.](#)
3. Disconnect the quick disconnect handle.  
[Refer to: Disconnect and Connect \(PIL 33-05-00\).](#)
4. Disconnect the batteries.  
[Refer to: Disconnect and Connect \(PIL 33-03-00\).](#)
5. Remove the relevant front wheel.  
[Refer to: Remove and Install \(PIL 27-29-00\).](#)
6. Disconnect the electrical terminals.
7. Remove the bolts (x4).
8. Remove the wheel drive motor.

### Install

1. The installation procedure is the opposite of the removal procedure. Additionally do the following steps.
2. Tighten the bolts to the correct torque value.
  - 2.1. Make sure that you follow the symmetrical pattern for the tightening sequence.

**Table 46. Torque Values**

Item	Nm
B	110

## 33 - Tyre

### 00 - General

#### Introduction

The wheel and tyre assemblies are a complete unit.  
[Refer to: PIL 27-29-00.](#)



Notes:

---



---



---



---



---



---



---



---



---



---



---



---



---



---



---



---



# 30 - Hydraulic System

Contents	Page No.
Acronyms Glossary .....	30-2
30-00 General	
30-00-00 General .....	30-3
30-00-49 Schematic Symbols .....	30-12
30-00-50 Schematic Circuit .....	30-16
30-03 Tank	
30-03-00 General .....	30-27
30-03-24 Breather .....	30-29
30-04 Filter	
30-04-00 General .....	30-31
30-04-09 Return Line .....	30-32
30-11 Gear Pump	
30-11-00 General .....	30-34
30-15 Cylinder / Ram	
30-15-00 General .....	30-37
30-15-34 Steering .....	30-40
30-15-75 Scissor Arm .....	30-42
30-15-99 Seal Kit .....	30-43
30-56 Main Control Valve Block	
30-56-00 General .....	30-46
30-60 Directional Control Valve	
30-60-51 Lift Cylinder .....	30-52
30-93 Hose	
30-93-00 General .....	30-57
30-97 Connectors	
30-97-00 General .....	30-60



---

## Acronyms Glossary

ARV	Auxiliary Relief Valve
MRV	Main Relief Valve
QRC	Quick Release Coupling
RPM	Revolutions Per Minute

## 00 - General

### 00 - General

Introduction .....	30-3
Health and Safety .....	30-4
Technical Data .....	30-5
Operation .....	30-6
Discharge and Pressurise .....	30-7
Drain and Fill .....	30-7
Clean .....	30-8
Check (Leaks) .....	30-9
Check (Level) .....	30-9
Check (Operation) .....	30-10
Check (Pressure) .....	30-10

### Introduction

The hydraulic system is a power transmission system that uses the force of flowing liquids to transmit power to specific components in a machine.

To help you trace specific hydraulic problems to a faulty unit (valve, actuator, ram etc.), refer to Fault finding. Once you have traced the faulty unit, refer to the relevant section for removal, disassembly and checking instructions.

To help identify circuits, valves, rams etc. mentioned in the fault finding procedures.

[Refer to: Diagram \(PIL 30-00-50\).](#)

- Before you begin fault finding, read the Health and Safety Information.  
[Refer to: Health and Safety \(PIL 30-00-00\).](#)
- Make simple checks before you remove or disassemble a major component.
- Make sure that the hydraulic fluid is at the correct working temperature 20°C (68.0°F)
- Whatever the fault, check the condition of the hydraulic fluid. Drain and replace if necessary. Refer to Hydraulic fluid quality in this procedure and Hydraulic System - Clean.  
[Refer to: Clean \(PIL 30-00-00\).](#)
- Make sure you remove ALL contamination and if possible identify its origin. It may be part of a component from elsewhere in the circuit.

### Hydraulic Contamination

Once inside the system, hydraulic circuit contaminants greatly affect the performance and life of hydraulic equipment. For example, contaminants in a hydraulic pump develop internal wear to cause internal leakage and hence lower discharges. Wear particles generated will circulate with the hydraulic fluid to cause further deterioration in the performance of this and other equipment. Contaminants also enter principal sliding sections of the equipment causing temporary malfunction, scuffing, sticking and leakage and can lead to major problems. The main contaminants can be classified as follows:

1. Solid Particles - Sand, fibres, metallic particles, welding scale, sealing materials and wear particles etc.
2. Liquid - Usually water and incompatible oils and greases.
3. Gases - Air, sulphur dioxide etc. which can create corrosive compounds if dissolved in the fluid.

These contaminants can appear during manufacture, assembly and operation.

## Health and Safety

### Hydraulic Pressure

Hydraulic fluid at system pressure can injure you. Before connecting or removing any hydraulic hose, residual hydraulic pressure trapped in the service hose line must be vented. Make sure the hose service line has been vented before connecting or removing hoses. Make sure the machine cannot be started while the hoses are open.

**WARNING!** *Fine jets of fluid at high pressure can penetrate the skin. Keep face and hands well clear of pressurised fluid and wear protective glasses. If fluid penetrates your skin, get medical help immediately.*

**WARNING!** *Take care when disconnecting hydraulic hoses and fittings as the oil will be hot.*

**WARNING!** *Damaged hoses can cause fatal accidents. Examine the hoses regularly. Do not use the machine if a hose or hose fixture is damaged.*

**Notice:** *Using incorrect fluid could damage the system. See Fluids, Capacities and Lubricants for the correct fluid. The fluid can harm your skin. Wear rubber gloves. Cover cuts or grazes.*

**Notice:** *Do not allow dirt to enter the system. Before disconnecting any part of the system, thoroughly clean around the connection. When a component has been disconnected, always install protective caps and plugs to prevent dirt ingress. Failure to follow these instructions will lead to dirt entering the system. Dirt in the system may seriously damage the systems components and could be expensive to repair.*

**CAUTION!** *The temperature of the hydraulic oil will be high soon after stopping the machine. Wait until it cools before beginning maintenance.*

**Notice:** *Using incorrect fluid could damage the system. See Fluids, Capacities and Lubricants for the correct fluid. The fluid can harm your skin. Wear rubber gloves. Cover cuts or grazes.*

**Technical Data**

- For: S1932E EDRV [RAJ] ..... Page 30-5
- For: S2632E EDRV [RAJ] ..... Page 30-5
- For: S3246E EDRV [RAJ] ..... Page 30-5
- For: S2646E EDRV [RAJ] ..... Page 30-5
- For: S4046E EDRV [RAJ] ..... Page 30-6
- For: S4550E EDRV [RAJ] ..... Page 30-6

(For: S1932E EDRV [RAJ])

**Table 47.**

Description	Data
Hydraulic oil	
Grade	ISO 32 or ISO 46 (As per requirement)
Operating temperature	For ISO 32: -20–30°C (-4.0–86.0°F)
	For ISO 46: -12–51°C (10.4–123.7°F)
Hydraulic pump	
Type	Gear, constant displacement
Flow rate at 3000 RPM (Revolutions Per Minute)	12L/min
Main control valve block	
MRV (Main Relief Valve) pressure	210bar (3,045.8psi)
Steering ARV (Auxiliary Relief Valve)	150bar (2,175.6psi)
Lowering restrictor size	1.5mm and 0.9mm in series
Oil return filter	
Type	10 Micron
Bypass pressure	1.7bar (24.7psi)

(For: S2632E EDRV [RAJ])

**Table 48.**

Description	Data
Hydraulic oil	
Grade	ISO 32 or ISO 46 (As per requirement)
Operating temperature	For ISO 32: -20–30°C (-4.0–86.0°F)
	For ISO 46: -12–51°C (10.4–123.7°F)
Hydraulic pump	
Type	Gear, constant displacement
Flow rate at 3000 RPM	12L/min
Main control valve block	
MRV pressure	210bar (3,045.8psi)

Description	Data
Steering ARV	150bar (2,175.6psi)
Lowering restrictor size	2.5mm and 1.3mm in series
Oil return filter	
Type	10 Micron
Bypass pressure	1.7bar (24.7psi)

(For: S3246E EDRV [RAJ])

**Table 49.**

Description	Data
Hydraulic oil	
Grade	ISO 32 or ISO 46 (As per requirement)
Operating temperature	For ISO 32: -20–30°C (-4.0–86.0°F)
	For ISO 46: -12–51°C (10.4–123.7°F)
Hydraulic pump	
Type	Gear, constant displacement
Flow rate at 3000 RPM	12L/min
Main control valve block	
MRV pressure	210bar (3,045.8psi)
Steering ARV	150bar (2,175.6psi)
Lowering restrictor size	1mm for upper 1.5mm for lower
Oil return filter	
Type	10 Micron
Bypass pressure	1.7bar (24.7psi)

(For: S2646E EDRV [RAJ])

**Table 50.**

Description	Data
Hydraulic oil	
Grade	ISO 32 or ISO 46 (As per requirement)
Operating temperature	For ISO 32: -20–30°C (-4.0–86.0°F)
	For ISO 46: -12–51°C (10.4–123.7°F)
Hydraulic pump	
Type	Gear, constant displacement
Flow rate at 3000 RPM	12L/min
Main control valve block	
MRV pressure	210bar (3,045.8psi)
Steering ARV	150bar (2,175.6psi)
Lowering restrictor size	1.5mm
Oil return filter	

Description	Data
Type	10 Micron
Bypass pressure	1.7bar (24.7psi)

(For: S4046E EDRV [RAJ])

**Table 51.**

Description	Data
Hydraulic oil	
Grade	ISO 32 or ISO 46 (As per requirement)
Operating temperature	For ISO 32: -20–30°C (-4.0–86.0°F)
	For ISO 46: -12–51°C (10.4–123.7°F)
Hydraulic pump	
Type	Gear, constant displacement
Flow rate at 3000 RPM	12L/min
Main control valve block	
MRV pressure	210bar (3,045.8psi)
Steering ARV	150bar (2,175.6psi)
Lowering restrictor size	1.2mm for upper
	1.4mm for lower
Oil return filter	
Type	10 Micron
Bypass pressure	1.7bar (24.7psi)

(For: S4550E EDRV [RAJ])

**Table 52.**

Description	Data
Hydraulic oil	
Grade	ISO 32 or ISO 46 (As per requirement)
Operating temperature	For ISO 32: -20–30°C (-4.0–86.0°F)
	For ISO 46: -12–51°C (10.4–123.7°F)
Hydraulic pump	
Type	Gear, constant displacement
Flow rate at 3000 RPM	12L/min
Main control valve block	
MRV pressure	210bar (3,045.8psi)
Steering ARV	150bar (2,175.6psi)
Lowering restrictor size	1.2mm for upper
	1.3mm for lower
Oil return filter	
Type	10 Micron
Bypass pressure	1.7bar (24.7psi)

## Operation

The main components of the hydraulic system are:

- Main valve block.  
[Refer to: PIL 30-56-00.](#)
- Gear pump.  
[Refer to: PIL 30-11-00.](#)
- Cylinder rams.  
[Refer to: PIL 30-15-00.](#)
- Hydraulic filter.  
[Refer to: PIL 30-04-00.](#)
- Hydraulic tank.  
[Refer to: PIL 30-03-00.](#)
- Lift cylinder valves.  
[Refer to: PIL 30-60-51.](#)

The hydraulic system is divided into two parts.

1. For steer operations.
2. For platform raise and lower operations.

The gear pump is driven by the control motor to supply pressurised oil to the hydraulic system. The pressurised hydraulic oil is supplied to the main control valve block, which directs this oil to different cylinder ram as per the inputs from the controller through the solenoid valves.

Relief valves in the system prevent undue pressure increases.

## Discharge and Pressurise

1. Make the machine safe with the platform lowered.  
[Refer to: PIL 01-03-27.](#)
2. Disconnect the speed control signal on the motor controller.
3. Operate the controls to remove the hydraulic pressure from the service hose lines.
4. Turn the machine key to position 0.
5. Remove the machine key.

## Drain and Fill

### Drain

1. Make the machine safe with the platform lowered.  
[Refer to: PIL 01-03-27.](#)
2. Discharge the hydraulic system.  
[Refer to: Discharge and Pressurise \(PIL 30-00-00\).](#)
3. Remove the hydraulic tank.  
[Refer to: Remove and Install \(PIL 30-03-00\).](#)
4. Drain the hydraulic oil into a suitable container.

### Fill

1. Install the hydraulic tank.  
[Refer to: Remove and Install \(PIL 30-03-00\).](#)
2. Fill the tank with the correct quantity and grade of hydraulic oil.  
[Refer to: PIL 75-00-00.](#)
3. Check the hydraulic oil level.  
[Refer to: Check \(Level\) \(PIL 30-00-00\).](#)

## Clean

### Special Tools

Description	Part No.	Qty.
Hydraulic Flushing Rig	892/01255	1

### Cleaning Operation

The purpose of cleaning oil is to remove contaminants of all types and sludge by filtering hydraulic fluid through a cleaning unit. Follow the instructions in the Hydraulic flushing rig instruction manual.

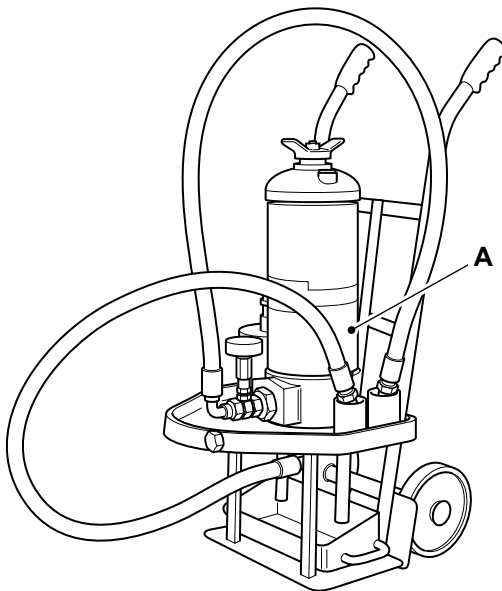
### Procedure

1. Connect the Hydraulic flushing rig in place of the hydraulic filter.  
**Special Tool: Hydraulic Flushing Rig (Qty.: 1)**
2. Run the system for sufficient time to pump all the hydraulic fluid through the unit.
3. Disconnect the cleaning unit and reconnect the filter.
4. Top up the system with clean hydraulic fluid as required.

- Red Blood Cell = 8 microns (0.008 mm, 0.000315 in)
- Human Hair = 70 microns (0.07 mm, 0.00275 in)
- Grain of Salt = 100 microns (0.1 mm, 0.00394 in)

The smallest particle visible to the naked eye is 40 microns (0.00157) approximately. Standards will often be quoted to ISO (International Standards Organisation) for which literature can be obtained.

**Figure 128.**



**A** Hydraulic flushing rig

### Contaminant Standards

Dirt that damages your system is in many cases too small to be seen with the eye. The particle size is measured in microns (1 micron = 0.001 mm (0.0000394 in)).

Listed below are a few typical comparisons:

## Check (Leaks)

**▲ WARNING** Fine jets of fluid at high pressure can penetrate the skin. Keep face and hands well clear of fluid under pressure and wear personal protective equipment. Hold a piece of cardboard close to suspected leaks and then examine the cardboard for signs of fluid. If fluid penetrates your skin, get medical help immediately.

**Notice:** If the fluid is cloudy, then water or air has contaminated the system. This could damage the hydraulic pump. Contact your JCB dealer immediately.

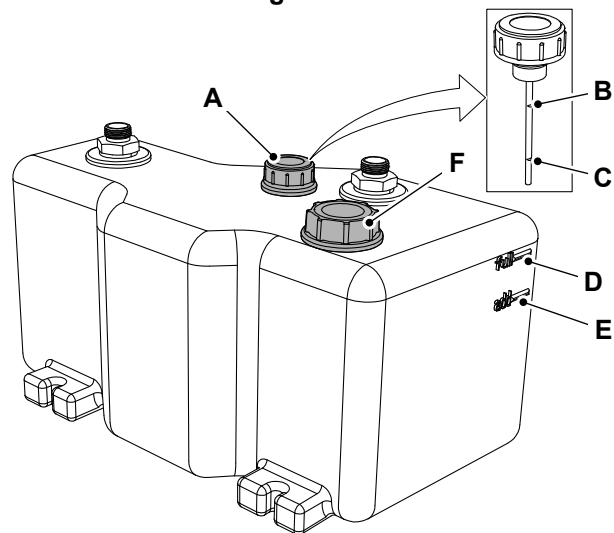
1. Make the machine safe with the platform raised.  
[Refer to: PIL 01-03-27.](#)
2. Open the hydraulic compartment door.  
[Refer to: Open and Close \(PIL 06-06-09\).](#)
3. Check for signs of hydraulic oil leaks, dripping or residue on or around the following components.
  - 3.1. Hydraulic tank and filter.
  - 3.2. Gear pump and main control valve block.
  - 3.3. Cylinder rams and hydraulic hoses.
4. Replace the O-rings wherever there are leaks.
5. Replace any damaged hoses or components.
6. Tighten the hydraulic adaptors as required.

## Check (Level)

**▲ Notice:** If the fluid is cloudy, then water or air has contaminated the system. This could damage the hydraulic pump. Contact your JCB dealer immediately.

1. Make the machine safe with the platform stowed.
2. Get access to the hydraulic compartment.
3. Check the oil level.
  - 3.1. Look at the Add/Full mark on the hydraulic oil tank. The hydraulic oil level must be between the marks. [Refer to Figure 129.](#)
  - 3.2. Alternatively, remove the breather cap. Check that the hydraulic oil level is between the two marks on the dipstick. [Refer to Figure 129.](#)
4. If necessary, add the recommended hydraulic fluid.
  - 4.1. Open the hydraulic oil filler cap.
  - 4.2. Use a suitable container to add the hydraulic fluid through the filler port.
  - 4.3. Check the level of hydraulic fluid.
  - 4.4. Close the filler cap.

**Figure 129.**



- A** Hydraulic breather
- B** Upper mark - maximum
- C** Lower mark - minimum
- D** Oil Full mark
- E** Oil Add mark
- F** Hydraulic oil filler cap

## Check (Operation)

Check the operation of all the hydraulic services.  
Check for:

- Speed of operation
- Strength of operation
- Juddering
- Abnormal noises.

Do not use the machine if one or more of these faults are found. You must make sure that the hydraulic service is repaired immediately.

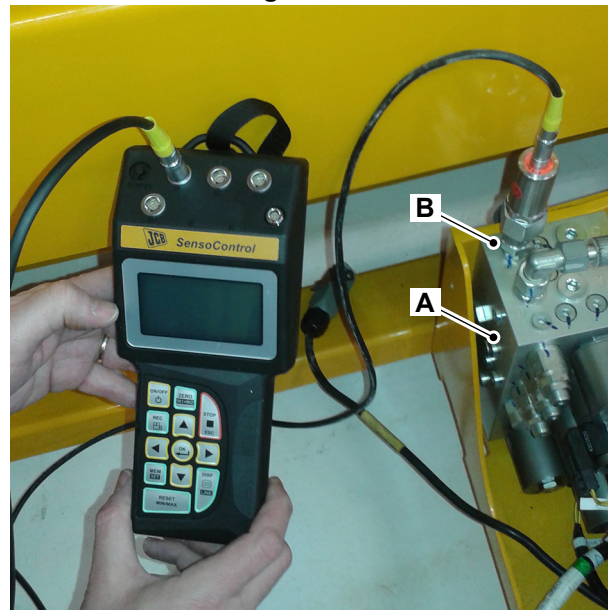
## Check (Pressure)

### Special Tools

Description	Part No.	Qty.
Digital Pressure Gauge 0-400 bar	892/01268	1
Hose for Pressure Gauge	892/01271	1
Digital Hydraulic Pressure Test Kit	998/11051	1

1. Make the machine safe with the platform lowered.  
[Refer to: PIL 01-03-27.](#)
2. Open the hydraulic compartment door.  
[Refer to: Open and Close \(PIL 06-06-09\).](#)
3. Connect the specified digital hydraulic pressure test kit to the pressure port on the main control valve block. [Refer to Figure 130.](#)  
**Special Tool: Digital Hydraulic Pressure Test Kit (Qty.: 1)**

**Figure 130.**



- A** Main control valve block
- B** Pressure port

- 3.1. If the digital hydraulic pressure test kit is not available, you can use the specified analogue pressure gauge and test hose.  
**Special Tool: Digital Pressure Gauge 0-400 bar (Qty.: 1)**  
**Special Tool: Hose for Pressure Gauge (Qty.: 1)**

4. Check the machine lift operating pressure as follows.

- 4.1. Lower the platform.
- 4.2. Put the rated load on the platform.
- 4.3. It is recommended to partially close the hydraulic compartment door for stability issues. You may route the hoses through the hole to close the hydraulic compartment door fully.
- 4.4. Raise the platform to approximately specified height.  
Distance: 3m
- 4.5. Observe the pressure gauge reading while raising the platform.
- 4.6. Make sure that the pressure readings are within the specified limits.  
[Refer to: Technical Data \(PIL 30-00-00\).](#)
5. Check the machine steer operating pressure as follows.
  - 5.1. Remove the wooden blocks from the front wheels.
  - 5.2. Steer the machine to left and right alternatively to full lock position.
  - 5.3. Observe the pressure gauge reading when the steering is on full lock.
  - 5.4. Make sure that the pressure readings are within the specified limits.  
[Refer to: Technical Data \(PIL 30-00-00\).](#)
6. Check the machine steer ARV (Auxiliary Relief Valve) pressure as follows.
  - 6.1. Disconnect the hydraulic hose from the AS and BS port of the main control valve block. Alternatively, you can disconnect the hoses from steer ram.  
[Refer to: Component Identification \(PIL 30-56-00\).](#)
  - 6.2. Plug the open hoses and ports to prevent contamination. Alternatively, you can use a suitable T-adaptor.
  - 6.3. Connect the specified pressure gauge to both the ports on the main control valve block or to both hoses (if you disconnect the hoses from steer ram).
  - 6.4. Operate the platform control unit left and right alternately.
  - 6.5. Observe the pressure gauge reading.
  - 6.6. Make sure that the pressure readings are within the specified limits.  
[Refer to: Technical Data \(PIL 30-00-00\).](#)



## 49 - Schematic Symbols

Introduction .....	30-12
Diagram .....	30-13

### Introduction

Complex hydraulic components and circuits can be described to the engineer by using graphical symbols. The tables illustrate and give a brief description for some of the more common symbols used.

There are many symbols in use and it would be impossible to include them all here. However it should be noted that most are only variations or refinements on the basic principles explained here. If more detailed information is required you are recommended to obtain a copy of BS2917 or ISO1219.

Once familiar with the symbols, the engineer can use hydraulic circuit diagrams as an aid to fault finding. It will be possible to see the complete hydraulic circuit and decipher the relationship between hydraulic components.

JCB © CONNOR STANMORE - 13/03/2026 07:57.

**Diagram**
**Table 53. General**

Symbol	Description
	Spring
	Flow restriction affected by viscosity
	Direction of flow
	Indication of rotation
	Indication of direction and paths of flow
	Variable control

**Table 54. Cylinder Rams**

Symbol	Description
	Single acting
	Double acting
	Double ended
	Double acting with damping at rod area end

**Table 55. Pumps and Motors**

Symbol	Description
	Variable capacity pump two directions of flow
	Fixed capacity motor one direction of flow
	Fixed capacity motor two directions of flow
	Variable capacity motor one direction of flow
	Variable capacity motor two directions of flow

**Table 56. Directional control valves**

Symbol	Description
	Used to enclose several valves indicating they are supplied as one unit
	3-Position, 4-port spring centered pilot operated valve
	3-position, 6-port spring centered manually operated valve
	3-Position, 4-port spring centered solenoid & pilot pressure operated valve
	3-Position, 4-port spring centered detent hand operated valve
	Non-return valve
	Non-return valve with back pressure spring
	Pilot operated non-return valve
	One way restrictor
	High pressure selector (shuttle valve)
	Throttling orifice - normally closed
	Throttling orifice - normally open
	Relief valve
	Variable restrictor




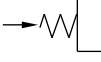



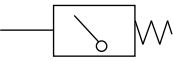
**Table 57. Energy Transmissions and Conditioning**

Symbol	Description
	Working line, return or feed
	Pilot control
	Drain lines
	Flexible pipe
	Line junction
	Crossing lines
	Air bleed
	Line plugged, also pressure test point
	Line plugged with take-off line
	QRC (Quick Release Coupling) - connected
	QRC - disconnected
	Tank - return line above fluid level
	Tank - return line below fluid level
	Header tank
	Pressure sealed tank
	Accumulator

Symbol	Description
	Filter or strainer
	Water trap
	Cooler - with no indication of coolant flow
	Cooler - indicating direction of coolant flow
	Heater

**Table 58. Control Mechanisms**

Symbol	Description
	Rotating shaft - one direction
	Rotating shaft - two directions
	Detent
	Locking device
	Over centre device
	Simple linkage
	General control
	Push button operated
	Lever operated
	Pedal operated
	Stem operated
	Spring operated
	Roller operated
	Roller trip operated (one directional)
	Solenoid one winding
	Solenoid two windings

Symbol	Description
	Electric motor operated
	Internal pressure pilot operated
	External pressure pilot operated
	Pressure operated spring release
	Pilot operated by solenoid pilot valve
	Pilot operated by a solenoid or separate pilot valve
	Pressure gauge
	Pressure switch



## 50 - Schematic Circuit

Introduction ..... 30-16  
Diagram ..... 30-17

## Introduction

A schematic diagram is a simplified pictorial representation of the machines hydraulic circuit. It shows the components of the circuit as simplified hydraulic symbols, and the connections between the different components. The schematic diagram is used to troubleshoot problems and to make sure that all the connections have been made and that everything is present. Detailed schematics for individual systems are given in the relevant PIL section.

JCB © CONNOR STANMORE - 13/03/2026 07:57.



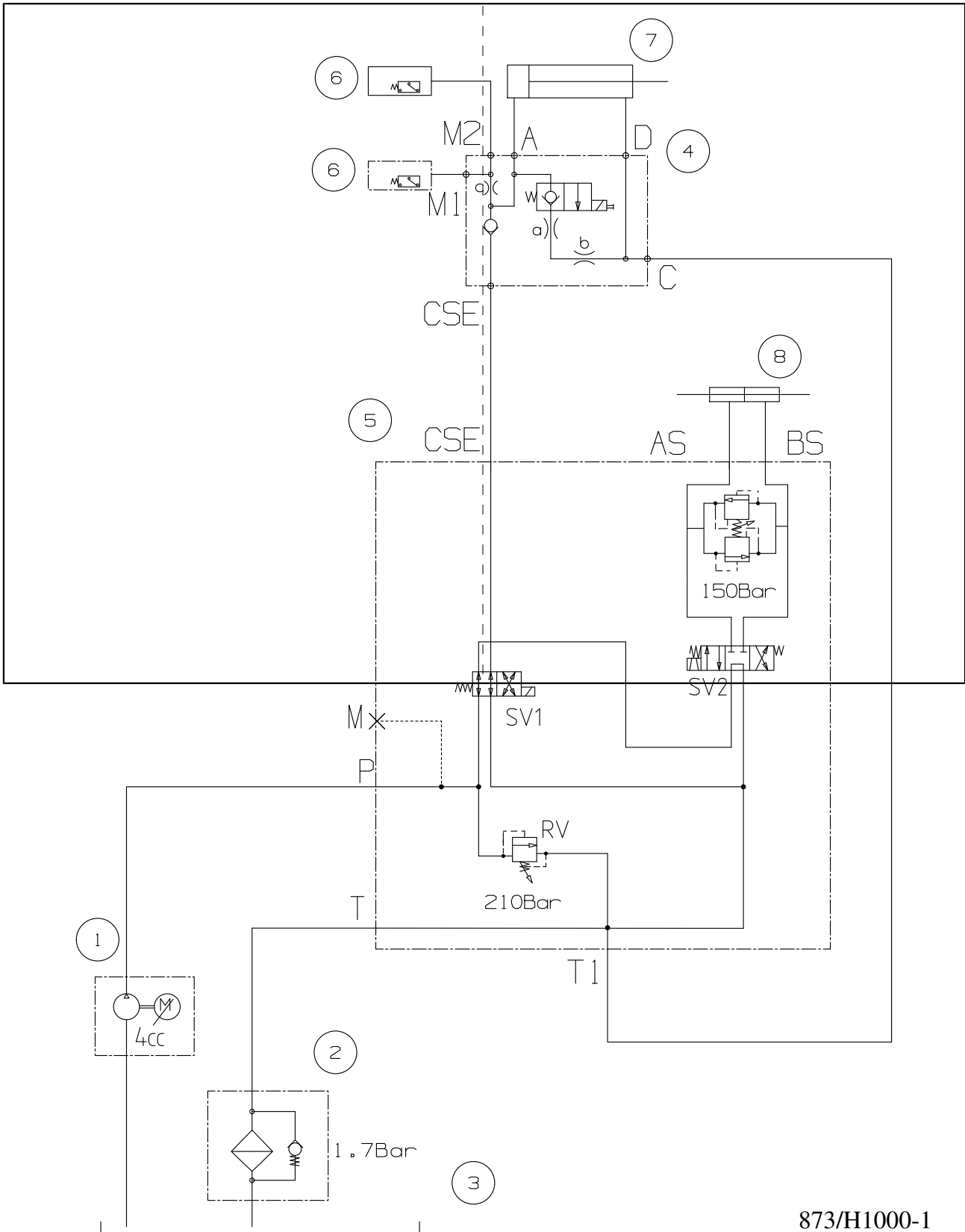
## Diagram

Figure 131. Hydraulic schematic - 873/H1000-1 (Sheet 1 of 2).....Page 30-19  
Figure 132. Hydraulic schematic - 873/H1000-1 (Sheet 2 of 2).....Page 30-23

JCB © CONNOR STANMORE - 13/03/2026 07:57.

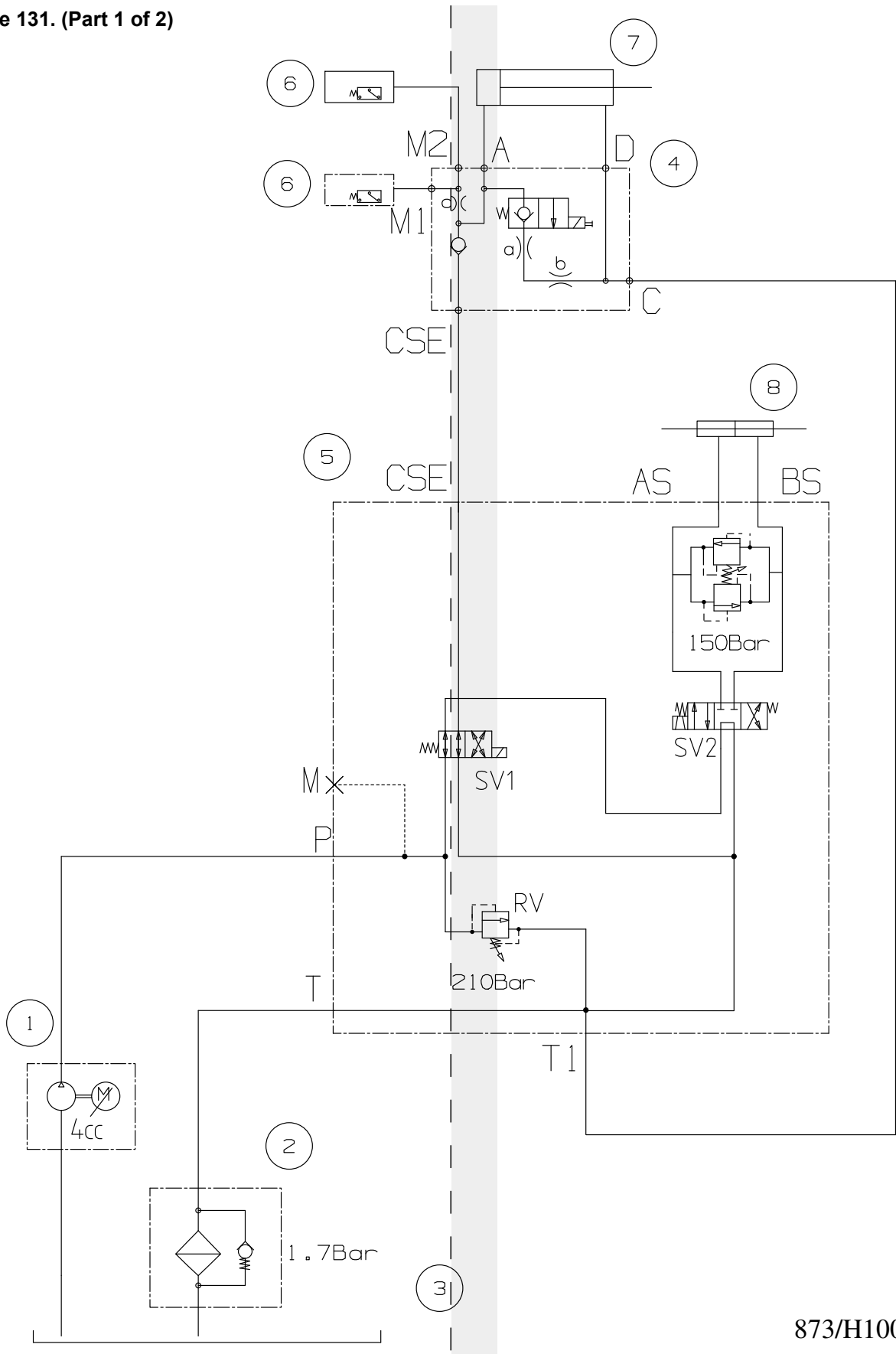


Figure 131. Hydraulic schematic  
- 873/H1000-1 (Sheet 1 of 2)



873/H1000-1

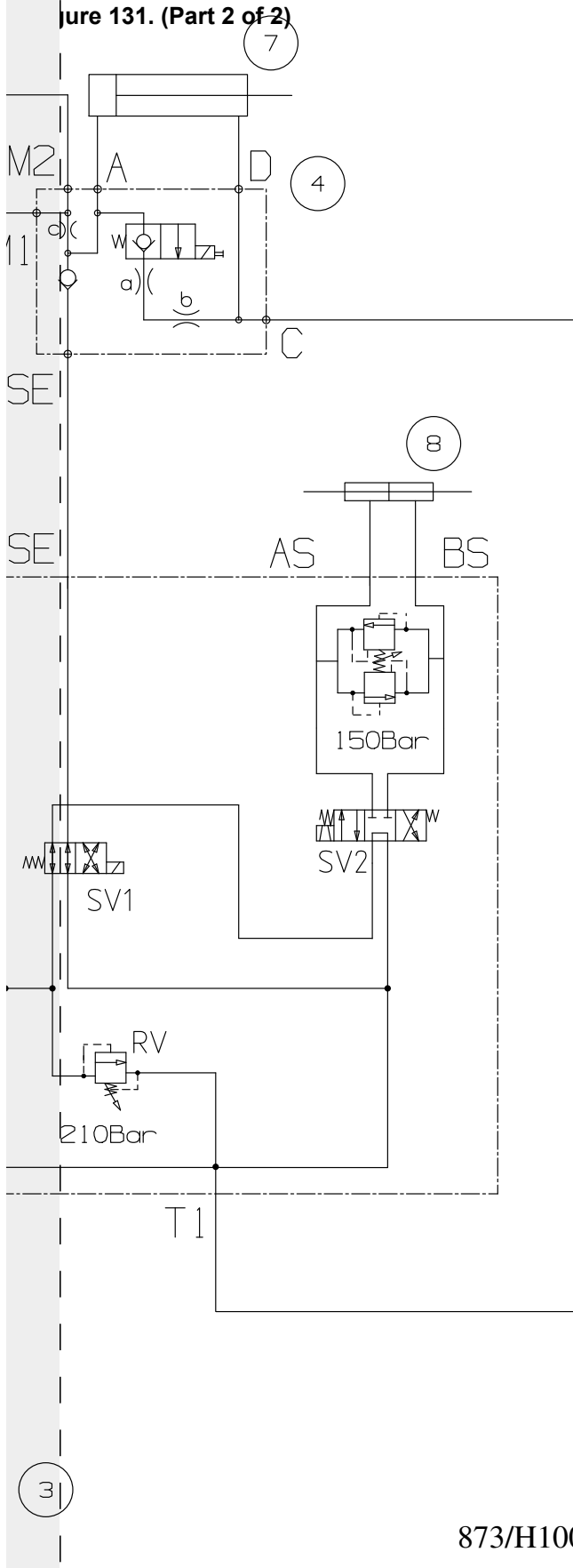
Figure 131. (Part 1 of 2)



Page 30-21

873/H1000-1

Figure 131. (Part 2 of 2)

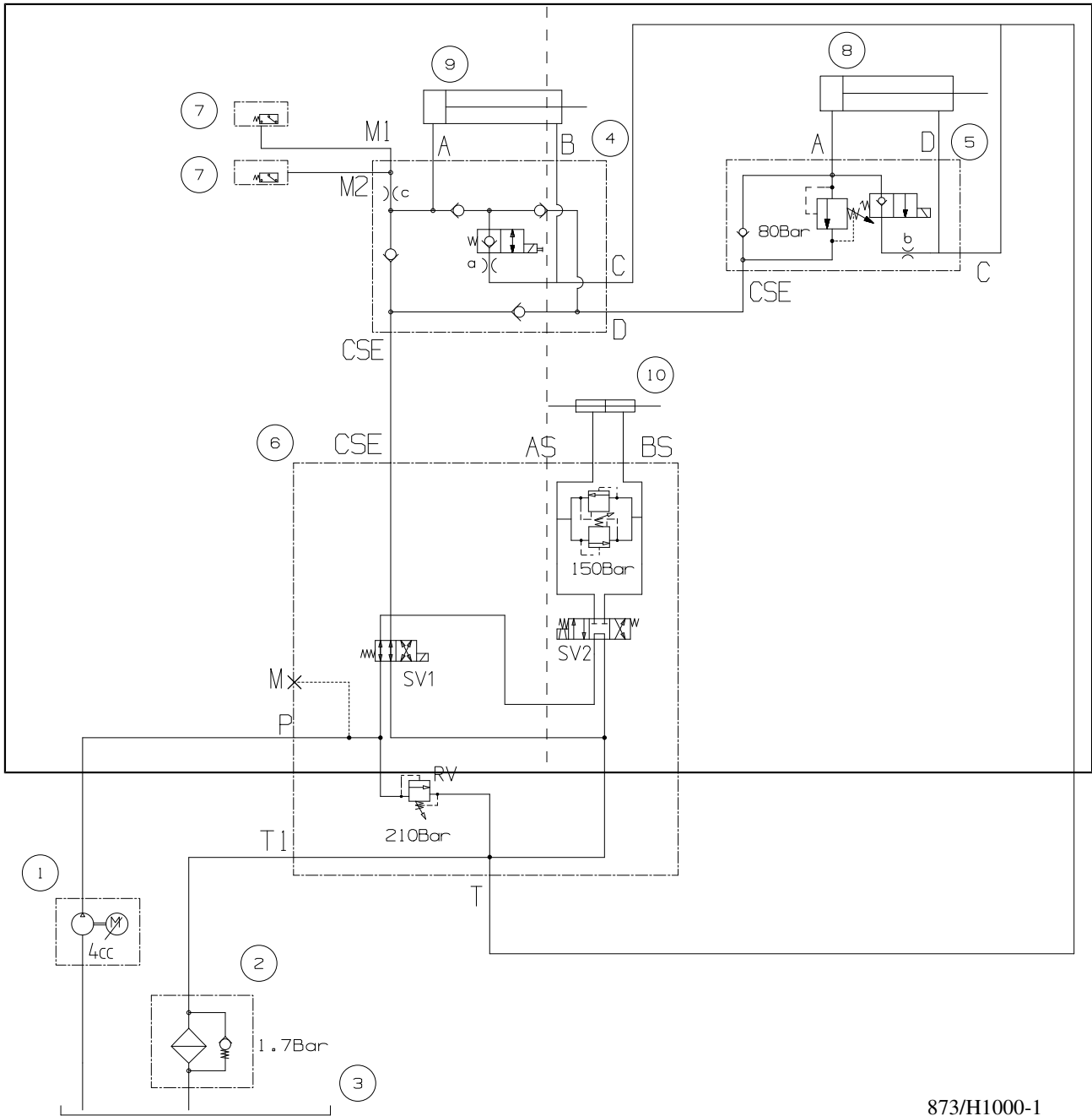


873/H1000-1



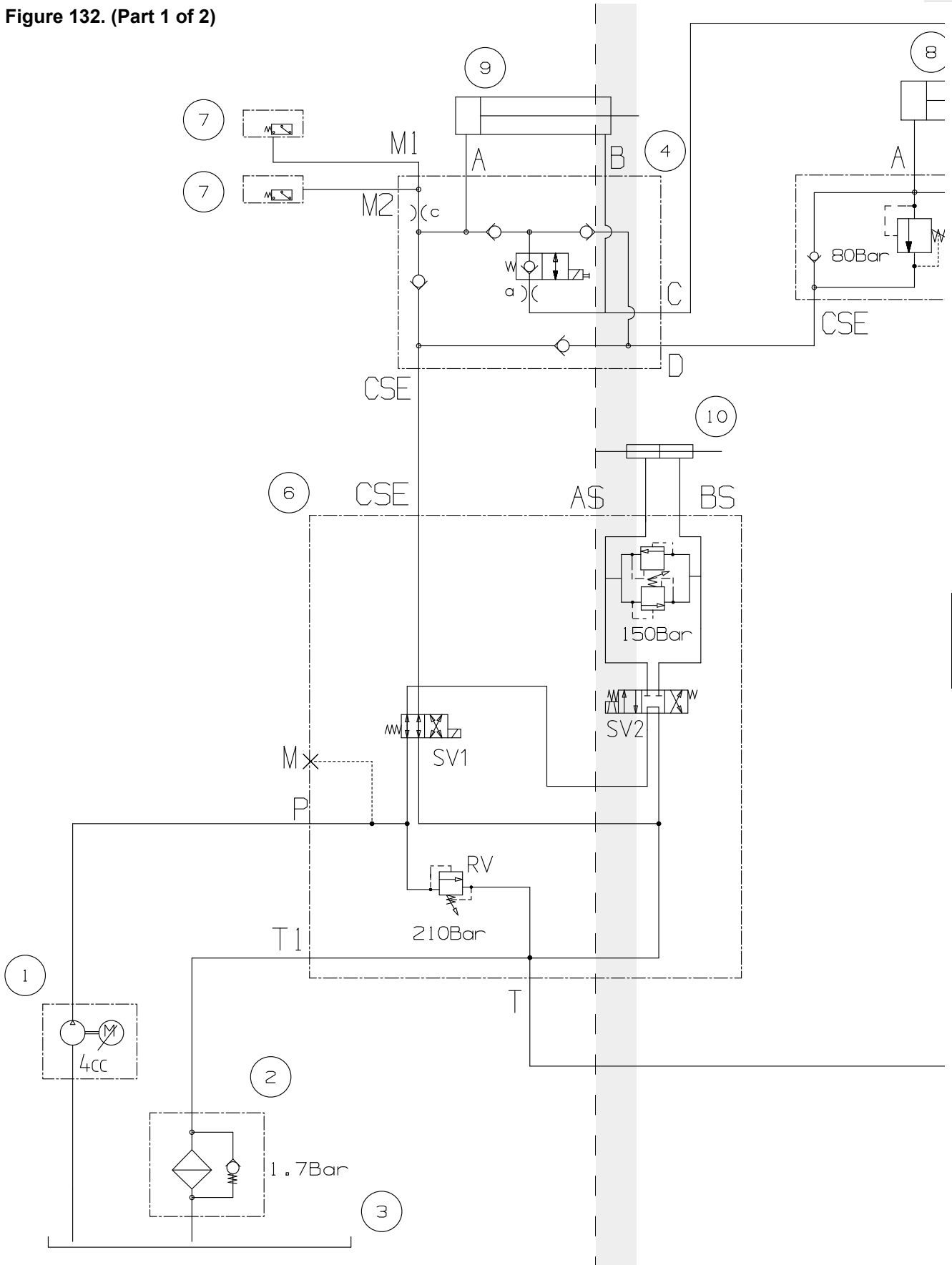
- |                       |   |
|-----------------------|---|
| 1 Gear pump           | 2 Return oil filter                       |
| 3 Hydraulic tank      | 4 Lower lift cylinder control valve block |
| 5 Main control valve  | 6 Pressure sensor                         |
| 7 Lower lift cylinder | 8 Steering cylinder                       |

Figure 132. Hydraulic schematic  
- 873/H1000-1 (Sheet 2 of 2)



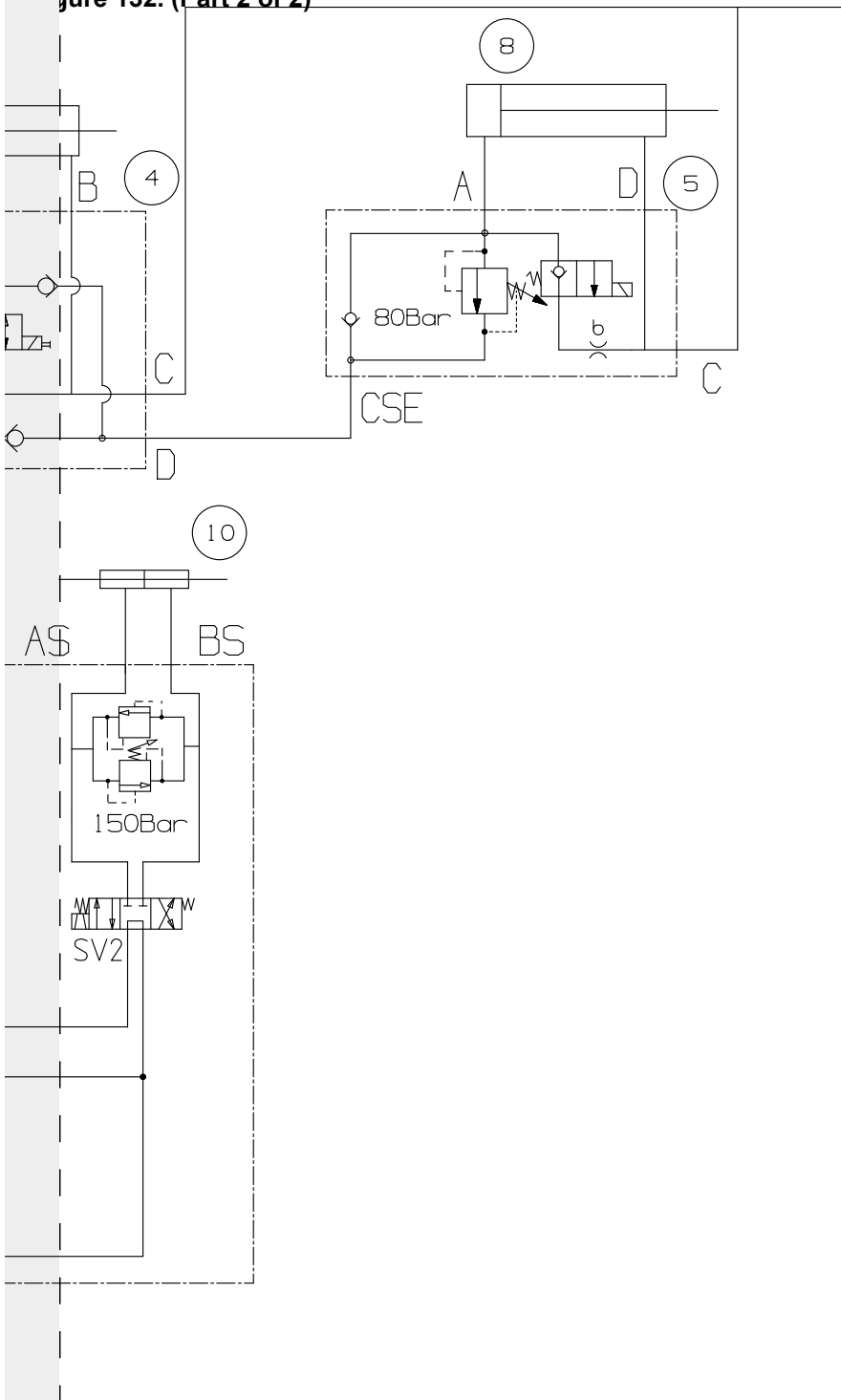
873/H1000-1

Figure 132. (Part 1 of 2)



Page 30-25

Figure 132. (Part 2 of 2)



Page 30-24

JCB © CONNOR STANMORE - 13/03/2026 07:57.

873/H1000-1

- |  |   |
|--|---|
| <ul style="list-style-type: none"> <li>1 Gear pump</li> <li>3 Hydraulic tank</li> <li>5 Upper lift cylinder control valve block</li> <li>7 Pressure sensor</li> <li>9 Lower lift cylinder</li> </ul> | <ul style="list-style-type: none"> <li>2 Return oil filter</li> <li>4 Lower lift cylinder control valve block</li> <li>6 Main control valve</li> <li>8 Upper lift cylinder</li> <li>10 Steering cylinder</li> </ul> |
|--|---|

**Table 59. Lift cylinder valve details**

Machine Model	G1 (a)	G1' (b)	G2 (c)
S1932E EDRV	1.5mm	0.9mm	0.9mm
S2632E EDRV	2.5mm	1.3mm	0.9mm
S2646E EDRV	1.6mm	-	0.9mm

**Table 60. Lift cylinder valve details**

Machine Model	Upper Lift Valve	Lower Lift Valve	
	G1 (b)	G1 (a)	G2 (c)
S3246E EDRV	1mm	1.5mm	0.9mm

**Table 61. Lift cylinder valve details**

Machine Model	Upper Lift Valve	Lower Lift Valve	
	ORF1 (b)	ORF2 (a)	ORF1 (c)
S4046E EDRV	1.2mm	1.4mm	0.9mm
S4550E EDRV	1.2mm	1.3mm	0.9mm

JCB © CONNOR STANMORE - 13/03/2026 07:57.



## 03 - Tank

### 00 - General

[Introduction](#) ..... 30-27  
[Remove and Install](#) ..... 30-28

### Introduction

The hydraulic tank holds excess hydraulic oil to accommodate volume changes due to the following:

- Cylinder ram extension and contraction.
- Temperature driven expansion and contraction.
- Hydraulic oil leaks.

The tank is designed to aid in the separation of air from the fluid.

The tank also houses filters or strainers that help to separate dirt and other particulates from the oil.

The cleanliness of this component is critical.  
[Refer to: Clean \(PIL 30-00-00\)](#).

JCB © CONNOR STANMORE - 13/03/2026 07:57.

## Remove and Install

### Remove

1. Make the machine safe with the platform lowered.  
Refer to: [PIL 01-03-27](#).
2. Disconnect the battery quick disconnect handle.  
Refer to: [Disconnect and Connect \(PIL 33-05-00\)](#).
3. Open the hydraulic compartment door.  
Refer to: [Open and Close \(PIL 06-06-09\)](#).
4. Remove the ground control panel (if required).  
Refer to: [Remove and Install \(PIL 33-24-04\)](#).
5. Disconnect the hydraulic hose connections.
6. Put a label on the hoses to help installation.
7. Plug all the open ports and hoses to prevent contamination.
8. Remove the bolts (x3), washers (x3) and nuts (x3).
9. Carefully lift and remove the hydraulic tank.

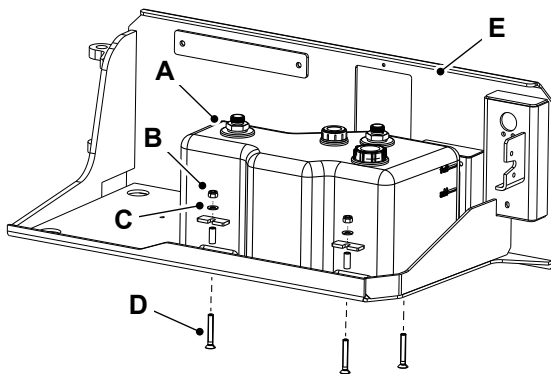
Refer to: [Technical Data \(PIL 75-00-00\)](#).

3.1. It is recommended to change the oil filter if oil is changed.

4. Check the hydraulic oil level.

Refer to: [Check \(Level\) \(PIL 30-00-00\)](#).

**Figure 133.**



- A** Hydraulic tank
- B** Nuts (x3)
- C** Washers (x3)
- D** Bolts (x3)
- E** Hydraulic compartment door

### Install

1. The installation procedure is the opposite of the removal procedure. Additionally do the following steps.
2. Tighten the bolts to the correct torque value.
3. Add the recommended grade of hydraulic oil.



## 24 - Breather

Introduction ..... 30-29  
Remove and Install ..... 30-30

### Introduction

The hydraulic tank breather allows air in and out of the tank. This smooths out the pressure fluctuations in the hydraulic tank as hydraulic fluid is rapidly drawn out from, or returned to the tank.

The breather also prevents contaminants like moisture and particles from entering the tank when air is drawn in. Contaminants can easily corrode, wear out or otherwise reduce the performance of a hydraulic system.

When air is expelled from the tank the breather prevents hydraulic fluid spillage.

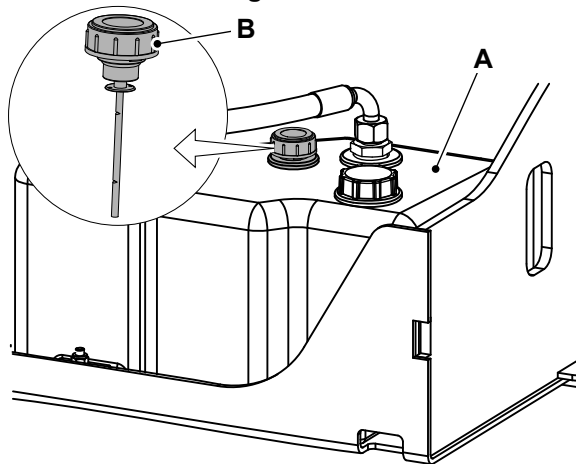
JCB © CONNOR STANMORE - 13/03/2026 07:57.

## Remove and Install

### Remove

1. Make the machine safe with the platform lowered.  
[Refer to: PIL 01-03-27.](#)
2. Open the hydraulic compartment door.  
[Refer to: Open and Close \(PIL 06-06-09\).](#)
3. Remove the breather cap.

**Figure 134.**



- A** Hydraulic tank  
**B** Breather cap

### Install

1. The installation procedure is the opposite of the removal procedure.

## 04 - Filter

### 00 - General

#### Introduction

Hydraulic filters are an important part of the machines hydraulic system. Metal particles are continually produced by mechanical components and need to be removed along with other contaminants.

The hydraulic filter assemblies are designed to filter all the contamination that is generated through use to the required level of cleanliness.

Filters are positioned in many different locations. Refer to the relevant hydraulic filter for the location and removal procedure.

The filters must be serviced to the requirements of the machine maintenance schedules. To ensure optimum performance and reliability it is important that the machine's hydraulic system is serviced periodically in accordance with the manufacturers requirements.



## 09 - Return Line

Introduction ..... 30-32  
Remove and Install ..... 30-33

## Introduction

The return line hydraulic filter is the main hydraulic filter installed on the return line close to the hydraulic tank.

The filter incorporates a bypass valve. If the filter becomes blocked, the bypass valve opens and allows fluid to bypass the filter. This prevents excessive back pressure which can damage the hydraulic system. The filter is not effective when the bypass valve is open.

JCB © CONNOR STANMORE - 13/03/2026 07:57.

## Remove and Install

### Remove

1. Make the machine safe with the platform lowered.  
[Refer to: PIL 01-03-27.](#)
2. Open the hydraulic compartment cover.  
[Refer to: PIL 06-06-09.](#)
3. Put a suitable oil absorbent cloth under the hydraulic filter to collect any residual oil.
4. Remove the hydraulic filter. If necessary, use a suitable strap wrench.
5. Discard the filter element.
6. Remove and discard the O-ring.

Table 61. Torque Values

Item	Description	Nm
B	Hydraulic hoses	25–35
C	Bolt	7–12
E	Hydraulic adaptors on the filter	120

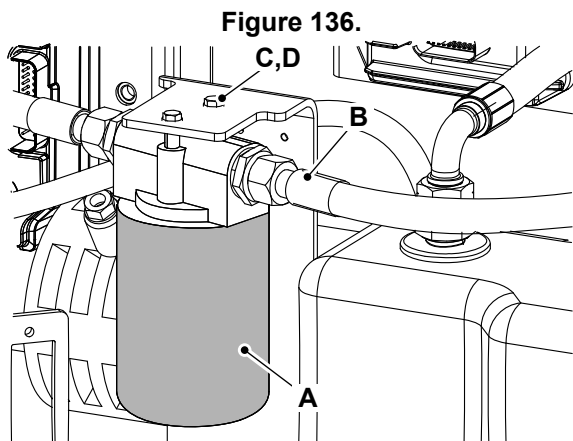


Figure 136.

- A Hydraulic filter
- B Hydraulic hoses
- C Bolt (x2)
- D Washer (x2)

### Install

1. The installation procedure is the opposite of the removal procedure. Additionally do the following steps.
2. Apply a thin layer of clean hydraulic oil to the O-ring before installation.  
[Refer to: Technical Data \(PIL 75-00-00\).](#)
3. Tighten the filter as follows.
  - 3.1. Install the filter by hand. Make sure that the filter forms the sealing contact.
  - 3.2. Further tighten the filter to one full turn by hand.
4. Check the hydraulic oil level and top up to the correct level.  
[Refer to: Check \(Level\) \(PIL 30-00-00\).](#)

## 11 - Gear Pump

### 00 - General

Introduction .....	30-34
Technical Data .....	30-35
Component Identification .....	30-35
Remove and Install .....	30-36

### Introduction

The gear pump consists of an end cover, a body, housing a matched gear pair, bushes and a mounting flange fixed together with bolts. The gear journals are supported in plain bearings within pressure balanced bushes to give high volumetric and mechanical efficiencies.

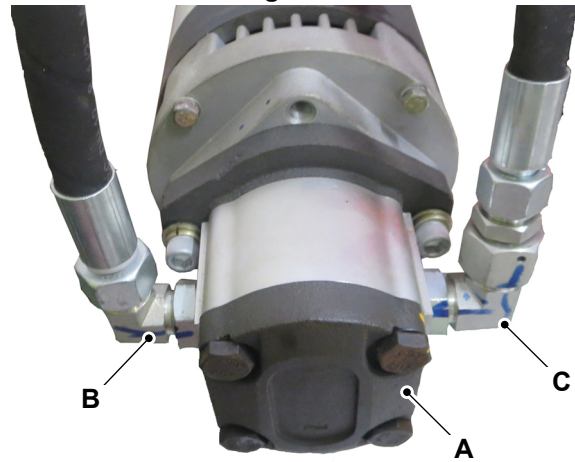
The direction of rotation of the pump is indicated by an arrow on the body near to the driveshaft.

## Technical Data

Refer to Hydraulic System- General, Technical Data.  
Refer to: [PIL 30-00-00](#).

## Component Identification

**Figure 138.**



- A** Gear pump
- B** Inlet port
- C** Outlet port



## **Remove and Install**

The Gear Pump remove and install procedure is given in the Pump Motor remove and install procedure.

[Refer to: Remove and Install \(PIL 33-10-00\).](#)



## 15 - Cylinder / Ram

### 00 - General

Introduction .....	30-37
Health and Safety .....	30-38
Check (Condition) .....	30-39

### Introduction

A hydraulic cylinder ram is a hydraulic actuator that is used to give a single directional force through a single action stroke. It is used in many applications, the cylinder gets the power from pressurised hydraulic oil. The hydraulic cylinder consists of a cylinder barrel, in which a piston connected to a piston rod moves back and forth.

The barrel is closed on one end by the cylinder cap and the other end by the cylinder head where the piston rod comes out of the cylinder. The piston has sliding rings and seals. The piston divides the inside of the cylinder into two chambers, the bottom chamber (cap end) and the piston rod side chamber (rod end / head end).

JCB © CONNOR STANMORE - 13/03/2026 07:57.

## Health and Safety

### Hydraulic Pressure

Hydraulic fluid at system pressure can injure you. Before connecting or removing any hydraulic hose, residual hydraulic pressure trapped in the service hose line must be vented. Make sure the hose service line has been vented before connecting or removing hoses. Make sure the machine cannot be started while the hoses are open.

### Lifting Equipment

You can be injured if you use incorrect or faulty lifting equipment. You must identify the weight of the item to be lifted then choose lifting equipment that is strong enough and suitable for the job. Make sure that lifting equipment is in good condition and complies with all local regulations.

**WARNING!** *A raised and badly supported machine can fall on you. Position the machine on a firm, level surface before raising one end. Ensure the other end is securely chocked. Do not rely solely on the machine hydraulics or jacks to support the machine when working under it. Disconnect the battery, to prevent the machine being started while you are beneath it.*

### Precautions for Installation

1. Precautions when installing the ram on the machine.
  - 1.1. When installing and removing from the machine, suspend the ram safely.
  - 1.2. Suspending the ram by the piping is not only dangerous, but can also cause damage to the cylinder.
  - 1.3. Secure the piston rod with a band. It is very dangerous if the rod extends unexpectedly. Also, the rod can be damaged and become unusable.
2. Welding after installing the ram may result in damage.
  - 2.1. If electric welding is done even at a point away from the ram, there may be sparking inside the ram and it will become necessary to replace the ram with a new one.
3. When painting the machine, mask the ram. If paint adheres to the rod surface or to the wiper ring and the ram is operated, the wiper ring will not function properly and foreign matter and paint can easily enter the ram. This will cause damage to the seals, drastically shortening the life of the ram.
4. Install the ram only when it is clean.

## Caution During Use

1. Use only under designated conditions.
  - 1.1. If hydraulic oil other than the designated oil is used, the seals quickly degenerate and become damaged. If the relief valve is set at a value higher than specified, it may cause ram damage and is dangerous.
  - 1.2. In high or low temperature environments, seals quickly become damaged. Special seal materials are necessary so check to see if the ram that you are using is suitable or not.
  - 1.3. The number one cause of ram oil leakage is rod damage. Be careful not to damage the rod.
2. Warm up sufficiently before beginning work.
  - 2.1. In cold conditions the rod seals may be frozen, so if the ram is operated at maximum pressure and maximum speed, the seals will be damaged.
  - 2.2. There is a large amount of air in a new ram or one which has been left for a long time, so the ram will not operate smoothly. Also, if pressure is applied suddenly without bleeding the air, high temperatures will be generated due to adiabatic compression and the seals may burn.
  - 2.3. Before beginning work, always move the ram at full stroke with no load and expel air from the cylinder.
3. When stopping or storing, do it at a safe and fixed position.
  - 3.1. The installed ram cannot maintain the same position for a long period of time, because the oil inside the ram may leak and the hydraulic oil volume decreases as it cools. Stop or store the machine in a safe and fixed position.

## Maintenance, Inspection Points

1. Carry out daily maintenance and inspection.
  - 1.1. The key point for correct long-term ram function is daily maintenance and inspection. Carry out maintenance and inspection so that the ram functions fully at all times. Always remove any mud, water, dust or oil film adhering to the rod and keep it in normal condition. However, when cleaning the wiper ring and seals, do not get them wet with water but wipe clean with a rag. To prevent rust forming during storage, the amount of exposed ram piston rod should be kept to a minimum. If leaving for

more than one week, apply a light coating of suitable grease or petroleum jelly to the exposed part of the ram piston rod.

2. Use genuine JCB parts when replacing parts.
  - 2.1. If parts other than genuine JCB parts are used, the desired results may not be obtained. Use only genuine JCB parts.
3. Caution during dismantling and reassembly.
  - 3.1. Dismantling the ram while it is still installed on the machine can be dangerous as unexpected movements of the machine can occur. Remove the ram from the machine and then dismantle.
  - 3.2. If reassembled with dirty hands, foreign matter can enter the ram causing a shorter life span and also the other hydraulic equipment may be damaged. Reassemble in a clean state.
  - 3.3. Follow the instructions in the diagrams regarding torque tightening for screwed parts. If the torque is too high or too low, it can cause damage.

## Check (Condition)

### Consumables

Description	Part No.	Size
Surface Cleaning Fluid	4103/1204	1L

1. Make the machine safe.  
[Refer to: PIL 01-03-27.](#)
2. Extend each ram fully.
3. Clean the piston, gland, piston rod and tube with cleaning solvent.  
[Consumable: Surface Cleaning Fluid](#)
4. Visually examine each ram for score marks, dents, leaks or similar defects.
5. Check the condition of the tube as follows.
  - 5.1. Illuminate the inside of the tube.
  - 5.2. Inspect the inside of the tube for deep grooves and other damage. If damaged, replace the tube.
  - 5.3. Remove small scratches on the inside of the tube with a medium grain emery cloth. Use the emery cloth with a rotary motion.
  - 5.4. Inspect the gland end of the tube for sharp edges that will cut the gland O-ring.
  - 5.5. Remove the sharp edges from the tube as required.
6. Check the condition of the piston rod as follows.
  - 6.1. Make sure that the piston rod is straight.
  - 6.2. If the piston rod is not straight, install a new piston rod.
  - 6.3. Inspect the piston for damage and wear.
  - 6.4. If the piston is damaged or worn, replace it.
7. Check the condition of the gland as follows.
  - 7.1. Inspect the gland for rust.
  - 7.2. Remove rust and clean as required.

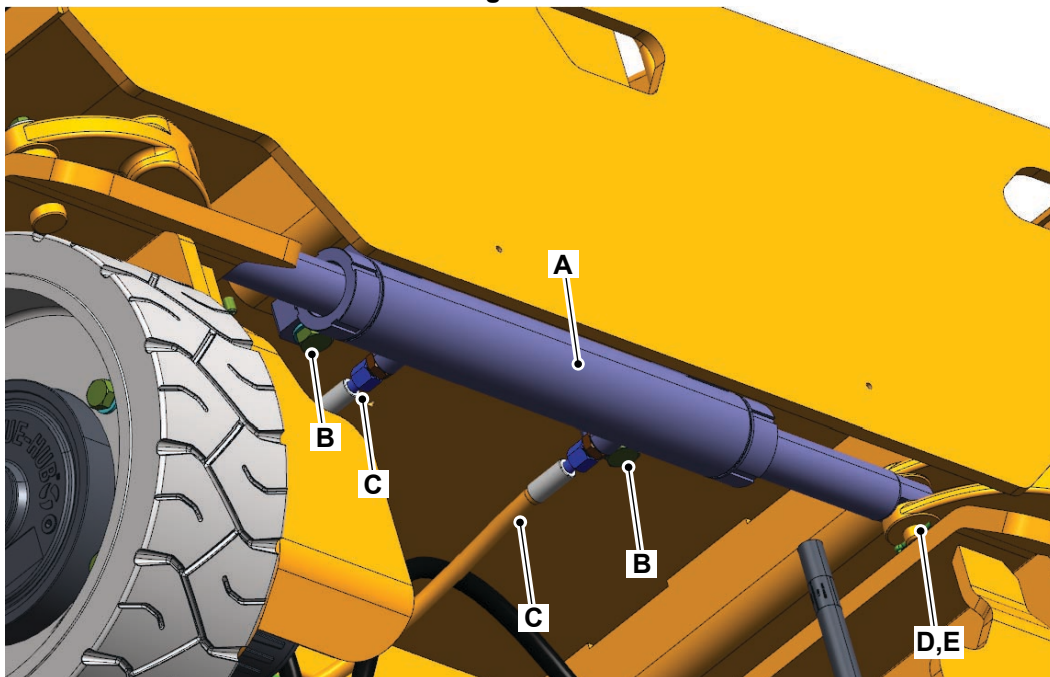
## 34 - Steering

### Remove and Install

#### Working Under the Machine

Make the machine safe. Make sure the park brake is engaged and machine is fully isolated. Remove the machine key switch, disconnect the battery. Use blocks to prevent unintentional movement of the wheels.

Figure 139.



**A** Steering cylinder ram

**C** Hose (x2)

**E** Pivot pin (x2)

**B** Bolt (x4)

**D** Split pin (x2)

#### Remove

1. Make the machine safe with the platform lowered.  
[Refer to: PIL 01-03-27.](#)
2. Discharge the hydraulic pressure.  
[Refer to: Discharge and Pressurise \(PIL 30-00-00\).](#)
3. Remove and discard the split pins from both ends of the ram.
4. Put a label on the hoses to help installation.
5. Disconnect the hydraulic hoses from the steering cylinder ram.

6. Plug all the open ports and hoses to prevent contamination.
7. Support the steering cylinder ram.
8. Use a suitable hammer and drift to remove the pivot pins.  
[Refer to: PIL 06-30-00.](#)
9. Remove the bolt (x4).
10. Remove the steering cylinder from the machine.

#### Install

1. The installation procedure is the reverse of the removal procedure. Additionally do the following steps.



- 2. Apply grease to the pivot pins in accordance to the maintenance schedule.

[Refer to: Technical Data \(PIL 75-00-00\).](#)

- 3. Check the hydraulic oil level and top up to the correct level.

[Refer to: Check \(Level\) \(PIL 30-00-00\).](#)

- 4. Tighten the bolt (x4) to the correct torque value.

**Table 61. Torque Values**

Item	Nm
B	260

JCB © CONNOR STANMORE - 13/03/2026 07:57.

## 75 - Scissor Arm

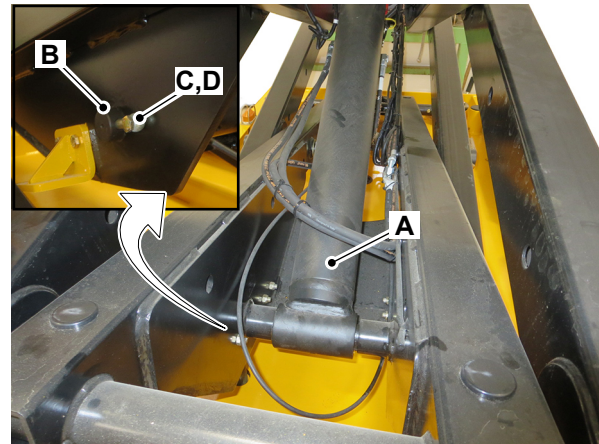
### Remove and Install

**▲ CAUTION** This component is heavy. It must only be removed or handled using a suitable lifting method and device.

#### Remove

1. Make the machine safe with the platform raised.  
[Refer to: PIL 01-03-27.](#)
2. Discharge the hydraulic pressure.  
[Refer to: Discharge and Pressurise \(PIL 30-00-00\).](#)
3. Support the platform with suitable lifting equipment. The scissor arm ram will not be supporting the weight of the scissor arm during this procedure. Therefore the safety strut will not work. You could get killed or injured if you do not support the scissor arm fully.
4. Put a label on the hoses to help installation.
5. Disconnect the hydraulic hoses from the scissor arm cylinder ram.
6. Plug all the open ports and hoses to prevent contamination.
7. Remove the guide sleeve from the piston rod with a suitable tool.
8. Support the scissor arm cylinder ram.
9. Remove the nut 1 and bolt 1 from the pivot pin 1.
10. Use a suitable hammer and drift to remove the pivot pin 1.  
[Refer to: Remove and Install \(PIL 06-30-00\).](#)

Figure 140.

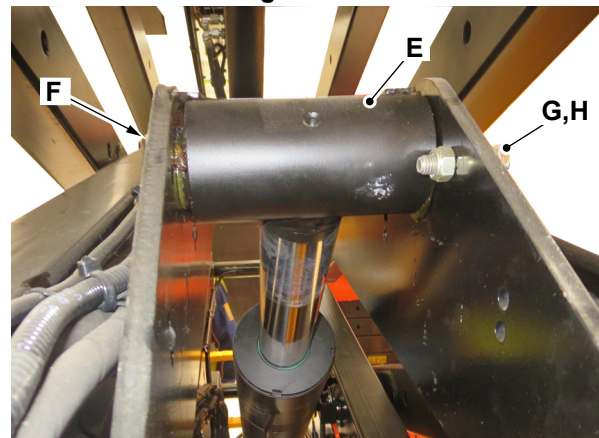


- A Head side - Scissor arm cylinder ram
- B Pivot pin 1
- C Bolt 1
- D Nut 1

11. Remove the nut 2 and bolt 2 from the pivot pin 2.
12. Use a suitable hammer and drift to remove the pivot pin 2.

[Refer to: Remove and Install \(PIL 06-30-00\).](#)

Figure 141.



- E Rod side - Scissor arm cylinder ram
- F Pivot pin 2
- G Bolt 2
- H Nut 2

13. Remove the scissor arm cylinder ram.

#### Install

1. The installation procedure is the opposite of the removal procedure.
2. Check the hydraulic fluid level and refill if necessary.

[Refer to: Check \(Level\) \(PIL 30-00-00\).](#)

## 99 - Seal Kit

### Remove and Install

#### Special Tools

Description	Part No.	Qty.
Ram Protection Sleeve (90mm rod diameter)	892/00167	1
Ram Seal Installation Tool	892/00334	1
Ram Protection Sleeve (25mm rod diameter)	892/01016	1
Ram Protection Sleeve (30mm rod diameter)	892/01017	1
Ram Protection Sleeve (40mm rod diameter)	892/01018	1
Ram Protection Sleeve (50mm rod diameter)	892/01019	1
Ram Protection Sleeve - Slew (50mm rod diameter)	892/01020	1
Ram Protection Sleeve (60mm rod diameter)	892/01021	1
Ram Protection Sleeve - Slew (60mm rod diameter)	892/01022	1
Ram Protection Sleeve (65mm rod diameter)	892/01023	1
Ram Protection Sleeve (70mm rod diameter)	892/01024	1
Ram Protection Sleeve (75mm rod diameter)	892/01025	1
Ram Protection Sleeve (80mm rod diameter)	892/01026	1
Ram Seal Assembly Tool	892/01027	1

#### Remove

1. Remove and discard the old seals.

Refer to: PIL 30-15-00.

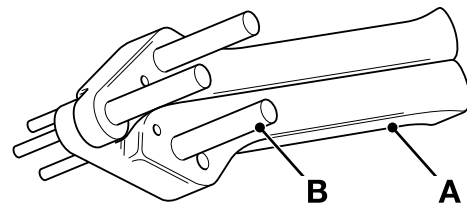
#### Install

1. Install new rod seals:

- 1.1. Use the ram seal installation tool to install rod seals, the size (diameter) and position of pins is determined by the diameter and radial width of the rod seal being installed. The pins are screwed into threaded holes in the tool body, the spacing of the holes is designed to suit small or large diameter rod seals.

Special Tool: Ram Seal Installation Tool (Qty.: 1)

Figure 142.

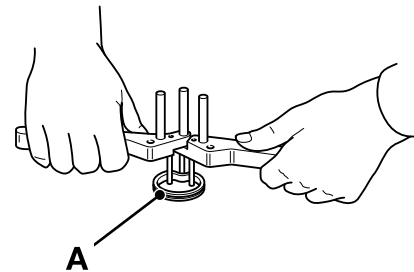


A Ram seal installation tool

B Pins

- 1.2. Open the seal installation tool and insert the new rod seal. Install the seal behind the two front pins but in front of the rear pin as shown.

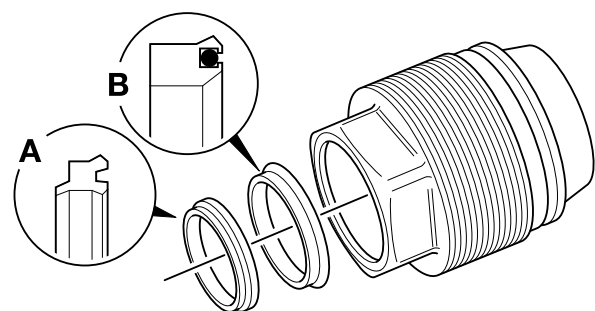
Figure 143.



A Rod seal

- 1.3. Later ram end caps and piston heads have metric threads. The seals are also different, make sure that the correct seals are installed. On metric threaded rams, make sure that the seals are installed the correct way around, as shown.

Figure 144.

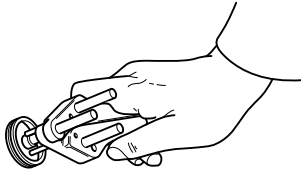


A Inner seal

B Outer seal

- 1.4. Close the tool. The seal must form a reniform (kidney shape).

**Figure 145.**



- 1.5. Before you install the rod seals, check that the seal grooves are free of contamination and sharp edges.
- 1.6. Locate the seal in the end cap groove. When the seal is in position, open the tool to release the seal. Make sure the seal is correctly installed in its groove and remove the tool.

**Figure 146.**

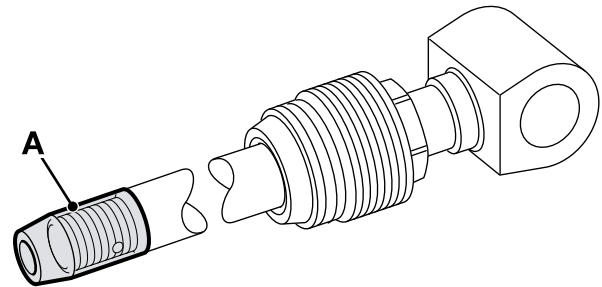


- 1.7. Install the rod wiper seal into the seal groove. Make sure that the seal is correctly installed as shown. Note: Some rod wipers, i.e. power track rod, may use a metal encased seal which is pressed into the housing. Care must be taken to make sure that the seal is square before it is pressed in.
- 1.8. A special sleeve must be used to protect the rod seals from damage, when installing the end cap on to the piston rod. There are various sizes of sleeve, make sure you use the correct size sleeve and also make sure that the hexagon on the end cap is towards the eye end of the rod.

- Special Tool: Ram Protection Sleeve (25mm rod diameter) (Qty.: 1)
- Special Tool: Ram Protection Sleeve (30mm rod diameter) (Qty.: 1)
- Special Tool: Ram Protection Sleeve (40mm rod diameter) (Qty.: 1)
- Special Tool: Ram Protection Sleeve (50mm rod diameter) (Qty.: 1)
- Special Tool: Ram Protection Sleeve - Slew (50mm rod diameter) (Qty.: 1)
- Special Tool: Ram Protection Sleeve (60mm rod diameter) (Qty.: 1)

- Special Tool: Ram Protection Sleeve - Slew (60mm rod diameter) (Qty.: 1)
- Special Tool: Ram Protection Sleeve (65mm rod diameter) (Qty.: 1)
- Special Tool: Ram Protection Sleeve (70mm rod diameter) (Qty.: 1)
- Special Tool: Ram Protection Sleeve (75mm rod diameter) (Qty.: 1)
- Special Tool: Ram Protection Sleeve (80mm rod diameter) (Qty.: 1)
- Special Tool: Ram Protection Sleeve (90mm rod diameter) (Qty.: 1)

**Figure 147.**

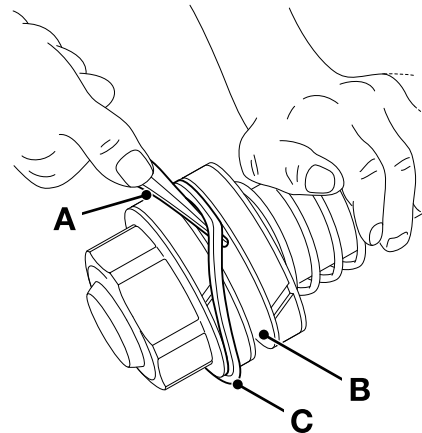


**A** Protection Sleeve (various sizes)

2. Install new head piston seals.
  - 2.1. Use the Piston seal assembly tool to lever the inner seal into the piston head seal groove. Do not let the seal twist. There are identification marks on the outer diameter of the seal, make sure that the marks are visible and the seal is free to rotate, if not remove the seal and retry.

Special Tool: Ram Seal Assembly Tool (Qty.: 1)

**Figure 148.**



**A** Piston seal assembly tool  
**B** Inner seal  
**C** Outer seal

- 2.2. Use the same procedure to install the outer seal as stated for the inner seal. Check that the external grooves are visible.
- 2.3. Make sure that the O-ring is installed into the internal seal groove on the piston head. Screw the piston head on to the thread of the piston rod and tighten to the correct torque value.

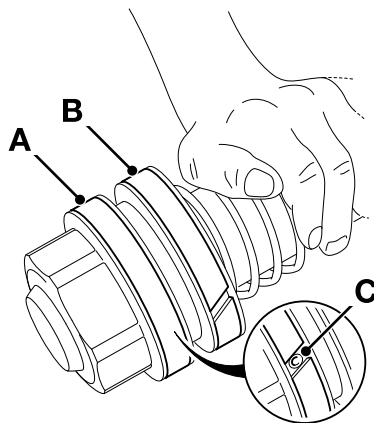
Refer to: [PIL 30-15-00](#).

- 2.4. Install the piston head retaining dowel.

Refer to: [PIL 30-15-00](#).

- 2.5. Install wear rings, rotate the wear rings so that the piston retention dowel is covered by the wear ring, not as shown at C.

**Figure 149.**



- A** Outer wear ring
- B** Inner wear ring
- C** Incorrect installation

3. Install the piston rod and head assembly into the cylinder.

- 3.1. Insert the piston/rod assembly into the cylinder ram. Align the rod and head assembly until parallel with the cylinder ram then push the assembly into the cylinder.

- 3.2. Install the end cap and assemble the ram assembly.

Refer to: [PIL 30-15-00](#).



## 56 - Main Control Valve Block

### 00 - General

Introduction .....	30-46
Component Identification .....	30-47
Operation .....	30-49
Remove and Install .....	30-50

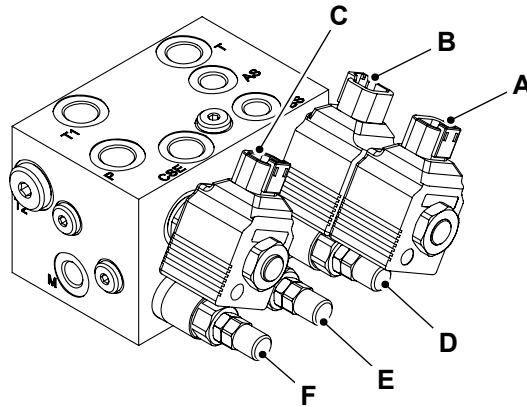
### Introduction

The main control valve block controls all hydraulic functional elements of the machine.

JCB © CONNOR STANMORE - 13/03/2026 07:57.

## Component Identification

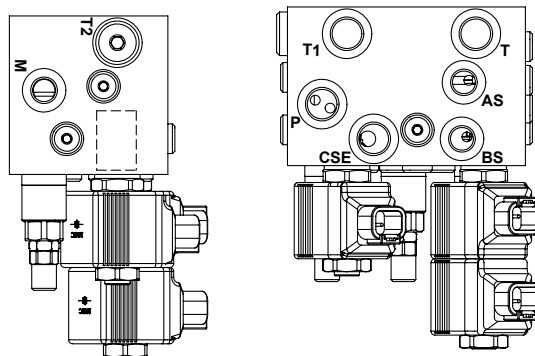
**Figure 150.**



**Table 62.**

Item	Description	Remarks
A	3-position 4-way solenoid DCV (Direction Control valve)	Steer
B	3-position 4-way solenoid DCV (Direction Control valve)	Steer
C	2-position 4-way solenoid DCV (Direction Control valve)	Platform lifting
D	ARV (Auxiliary Relief Valve)	Steering pressure control
E	ARV	Steering pressure control
F	MRV (Main Relief Valve)	System pressure control

**Figure 151.**



**Table 63.**

Item	Description
AS	Steer outlet port
BS	Steer outlet port
CSE	Lift outlet port
P	Pump inlet port

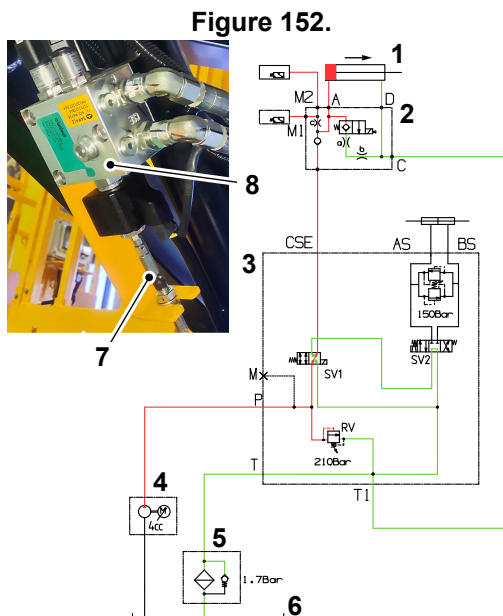


<b>Item</b>	<b>Description</b>
T	Lift Outlet Port
T2	Filter Inlet Port
CSE	Lift Inlet Port

## Operation

### Raising Platform

When platform raise is operated, the pressurised oil generated from the gear pump flows into the main control valve block. The raise solenoid valve changes position after energization and the pressurised oil flows into the head port of the lift cylinder through the check valve. As the lift cylinder extends, the platform raises and the oil in the rod port returns back to the oil tank through the return line.



- 1 Scissor arm cylinder ram
- 2 Scissor arm cylinder control valve
- 3 Main control valve block
- 4 Gear pump
- 5 Hydraulic return filter
- 6 Hydraulic tank
- 7 Emergency lower cable
- 8 Solenoid valve (Lower)

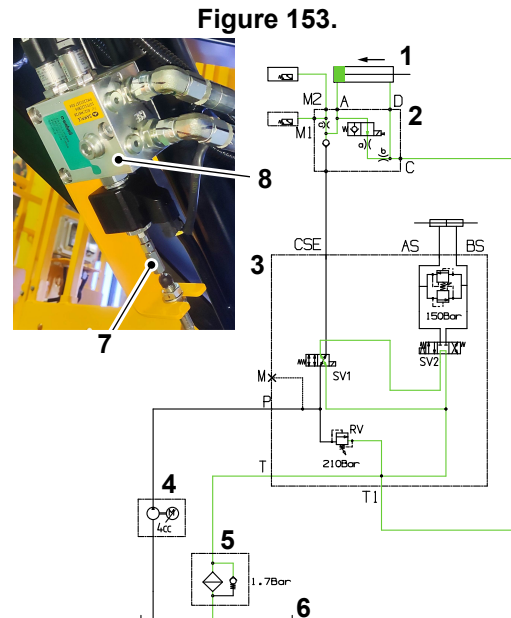
### Lowering Platform

When platform lower is operated, the lower solenoid valve at the cylinder valve block is energized. The oil in the head port of the lift cylinder flows back to the oil tank through this valve under the action of the platform load. Some of the oil will flow back into the rod port. During the lowering operation, the oil flows through a restrictor, which controls the lowering speed. (Refer to table for restrictor sizes for each model.)

For two-cylinder systems, both cylinders have lower solenoid valves. The oil flows from the upper cylinder to the lower cylinder, then to tank.

If platform lower is operated by the manual lowering lever, the cable from the lever pulls the lower valve of

the lower cylinder open, allowing the lower cylinder to retract under the action of the platform load. The upper cylinder also retracts as oil from the upper cylinder then flows through the ARV (Auxiliary Relief Valve) at the upper cylinder valve block, since the pressure difference increases above the setting pressure.



- 1 Scissor arm cylinder ram
- 2 Scissor arm cylinder control valve
- 3 Main control valve block
- 4 Gear pump
- 5 Hydraulic return filter
- 6 Hydraulic tank
- 7 Emergency lower cable
- 8 Solenoid valve (Lower)

## Remove and Install

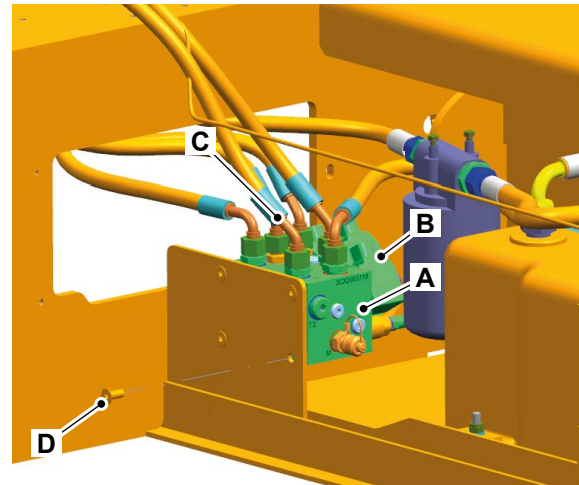
For: S1932E EDRV [RAJ] ..... Page 30-50  
 For: S2632E EDRV [RAJ], S2646E EDRV [RAJ], S3246E EDRV [RAJ], S4046E EDRV [RAJ], S4550E EDRV [RAJ] ..... Page 30-50

(For: S1932E EDRV [RAJ])

### Remove

1. Make the machine safe with the platform lowered.  
 Refer to: [PIL 01-03-27](#).
2. Discharge the hydraulic pressure.  
 Refer to: [Discharge and Pressurise \(PIL 30-00-00\)](#).
3. Open the hydraulic compartment door.  
 Refer to: [Open and Close \(PIL 06-06-09\)](#).
4. Put a label on the hoses and electrical connections to help installation.
5. Disconnect the hydraulic hoses from the main control valve block.
6. Plug all the open ports and hoses to prevent contamination.
7. Disconnect the electrical connections from the solenoids.
8. Open the battery compartment door.  
 Refer to: [Open and Close \(PIL 06-06-03\)](#).
  - 8.1. Make a note that the access to the mounting fasteners of the main control valve block is from the battery compartment.
9. Support the main control valve block.
10. Remove the capscrews (x4).
11. Remove the main control valve block.

Figure 156.



- A** Main control valve block
- B** Electrical connections
- C** Hydraulic hoses
- D** Capscrews (x4)

### Install

1. The installation procedure is the opposite of the removal procedure.
2. Tighten the hydraulic hoses to the correct torque value.
3. Check the hydraulic oil level and top up to the correct level.  
 Refer to: [Check \(Level\) \(PIL 30-00-00\)](#).

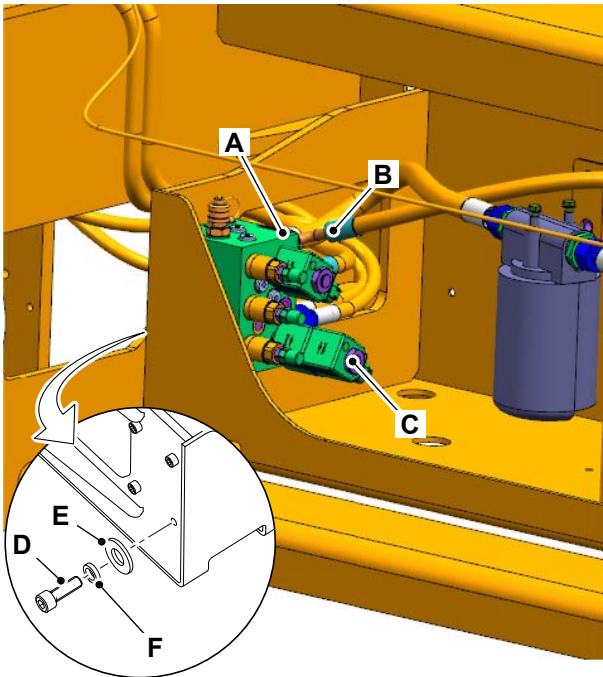
(For: S2632E EDRV [RAJ], S2646E EDRV [RAJ], S3246E EDRV [RAJ], S4046E EDRV [RAJ], S4550E EDRV [RAJ])

### Remove

1. Make the machine safe with the platform lowered.  
 Refer to: [PIL 01-03-27](#).
2. Discharge the hydraulic pressure.  
 Refer to: [Discharge and Pressurise \(PIL 30-00-00\)](#).
3. Open the hydraulic compartment door.  
 Refer to: [Open and Close \(PIL 06-06-09\)](#).
4. Put a label on the hoses and electrical connections to help installation.
5. Disconnect the hydraulic hoses from the scissor arm control valve block.
6. Plug all the open ports and hoses to prevent contamination.

7. Disconnect the electrical connections from the solenoids.
8. Support the main control valve block.
9. Remove the capscrews (x4), spring washers (x4) and washers (x4).
10. Remove the main control valve block.

**Figure 157.**



- A** Main control valve block
- B** Hydraulic hoses
- C** Electrical connections
- D** Capscrews (x4)
- E** Washers (x4)
- F** Spring Washers (x4)

**Install**

1. The installation procedure is the opposite of the removal procedure.
2. Check the hydraulic oil level and top up to the correct level.

[Refer to: Check \(Level\) \(PIL 30-00-00\).](#)

## 60 - Directional Control Valve

### 51 - Lift Cylinder

Component Identification ..... 30-52  
Remove and Install ..... 30-55

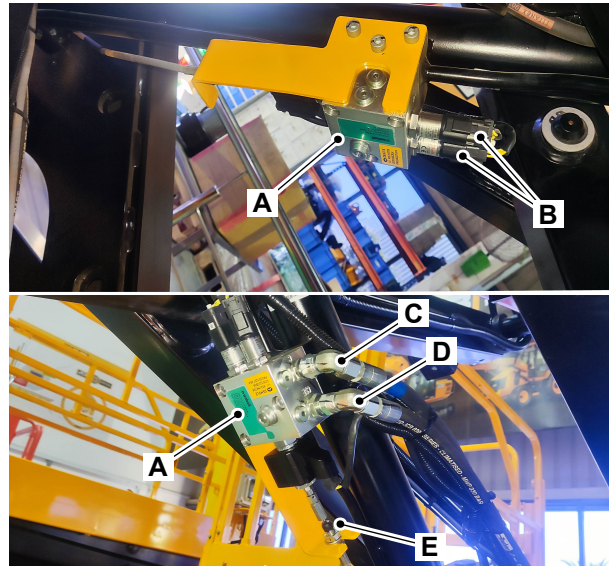
### Component Identification

For: S1932E EDRV [RAJ], S2632E EDRV [RAJ], S2646E EDRV [RAJ] ..... Page 30-52

For: S3246E EDRV [RAJ], S4046E EDRV [RAJ], S4550E EDRV [RAJ] ..... Page 30-53

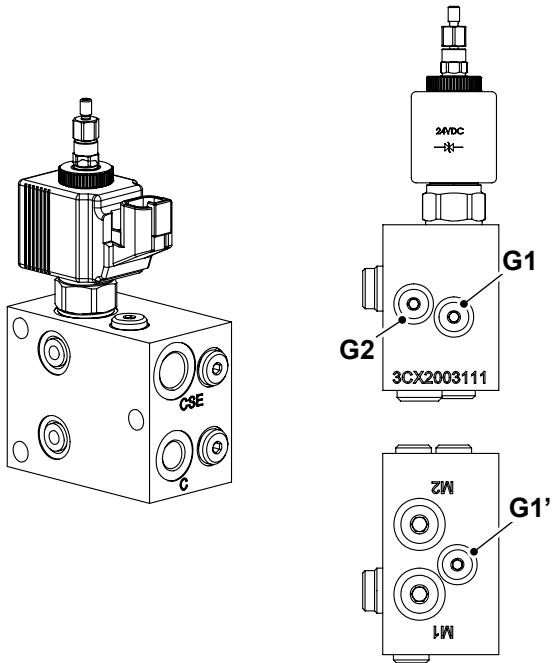
(For: S1932E EDRV [RAJ], S2632E EDRV [RAJ], S2646E EDRV [RAJ])

Figure 158.



- A** Lift cylinder control valve
- B** Pressure sensors
- C** Hydraulic return line to tank
- D** Hydraulic pressure line from pump
- E** Lowering solenoid with emergency lower cable

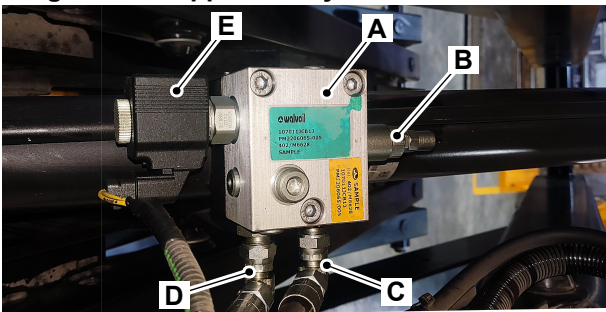
**Figure 159. Orifice**



- G1** Orifice 1
- G1'** Orifice 2
- G2** Orifice 3

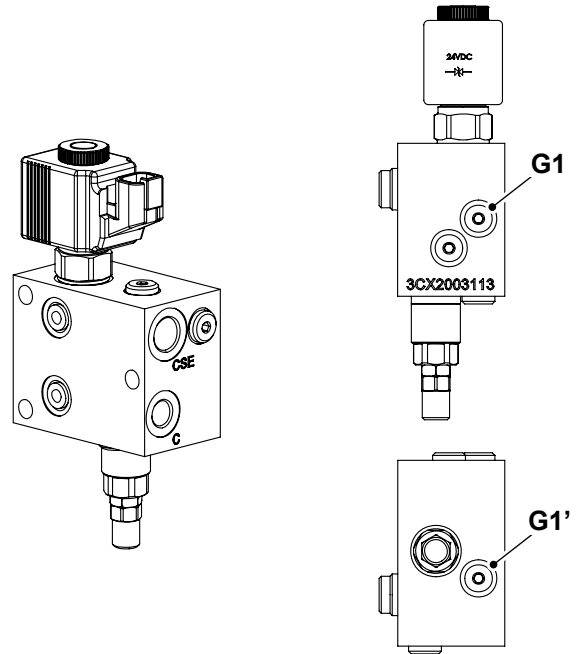
(For: S3246E EDRV [RAJ], S4046E EDRV [RAJ], S4550E EDRV [RAJ])

**Figure 160. Upper Lift Cylinder Control Valve**



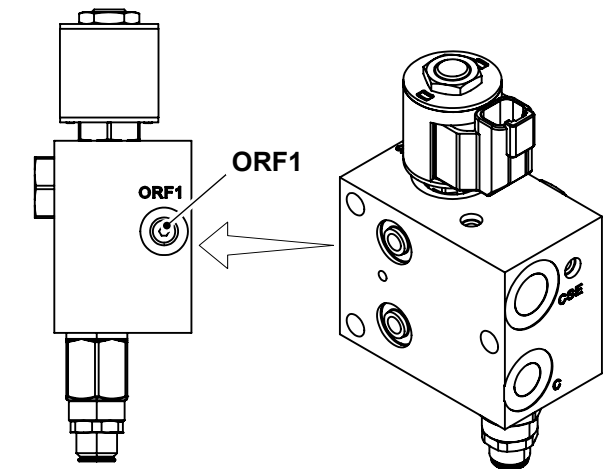
- A** Lift cylinder control valve
- B** Upper cylinder relief valve
- C** Hydraulic return line to tank
- D** Hydraulic pressure line from pump
- E** Lowering solenoid

**Figure 161. Upper Lift Cylinder Control Valve Orifice (for S3246E EDRV)**



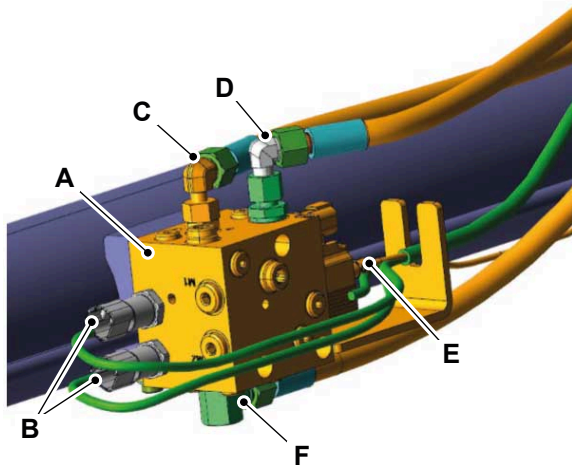
- G1** Orifice 1
- G1'** Orifice 2

**Figure 162. Upper Lift Cylinder Control Valve Orifice (for S4046E EDRV, S4550E EDRV)**



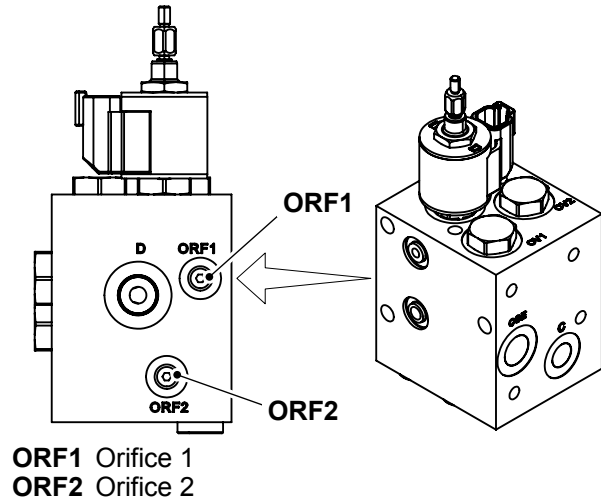
- ORF1** Orifice 1

**Figure 163. Lower Lift Cylinder Control Valve**

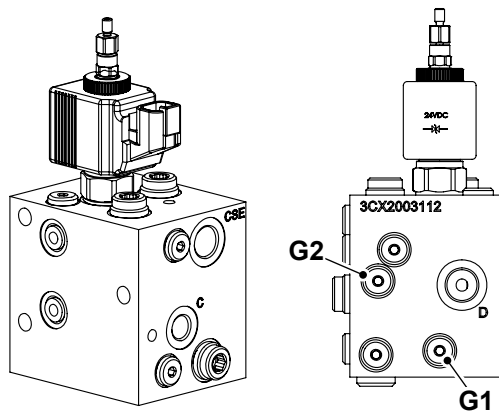


- A** Lift cylinder control valve
- B** Pressure sensors
- C** Hydraulic return line to tank
- D** Hydraulic pressure line from pump
- E** Lowering solenoid with emergency lower cable
- F** Upper cylinder supply line

**Figure 165. Lower Lift Cylinder Control Valve Orifice (for S4046E EDRV, S4550E EDRV)**



**Figure 164. Lower Lift Cylinder Control Valve Orifice (for S3246E EDRV)**



- G1** Orifice 1
- G2** Orifice 3

## Remove and Install

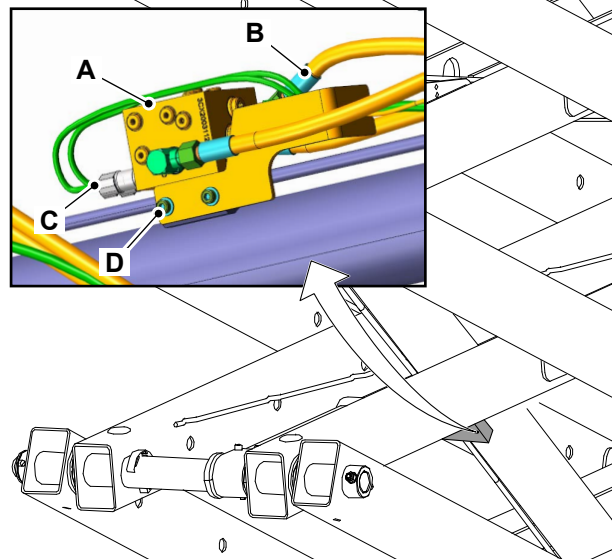
### Lower Lift Cylinder Control Valve

The single cylinder ram machines are installed with the lower lift cylinder control valve only.

#### Remove

1. Make the machine safe with the platform raised.  
[Refer to: PIL 01-03-27.](#)
2. Discharge the hydraulic pressure.  
[Refer to: Discharge and Pressurise \(PIL 30-00-00\).](#)
3. Install the safety strut. Danger or injury will result if the scissor arm is not supported fully.  
[Refer to: PIL 01-03-27.](#)
4. Put a label on the hoses and harness connections to help installation.
5. Disconnect the electrical connections to the sensors.
6. Disconnect the hydraulic hoses from the main control valve.
7. Plug all the open ports and hoses to prevent contamination.
8. Remove the emergency lower cable.  
[Refer to: Remove and Install \(PIL 06-93-03\).](#)
9. Support the valve.
10. Remove the capscrews (x3).
  - 10.1. Carefully remove the capscrews to release any trapped pressure. Take care to avoid any risk of contact with high pressure hydraulic fluid.
11. Remove the lift cylinder control valve.

Figure 166.



- A** Lift cylinder control valve (Lower)
- B** Hydraulic hoses
- C** Electrical connections
- D** Capscrews (x3)

#### Install

1. The installation procedure is the opposite of the removal procedure. Additionally do the following steps.
2. Make sure that the contact surfaces are clean.
3. Lightly lubricate all the O-rings. Make sure that all O-rings are correctly seated when assembling.
4. Tighten the screws to the correct torque value.
5. Check the hydraulic fluid level and refill if necessary.  
[Refer to: Check \(Level\) \(PIL 30-00-00\).](#)
6. Replace the lowering restrictor as follows.  
[Refer to: Component Identification \(PIL 30-60-51\).](#)
  - 6.1. Put the valve on a clean workbench.
  - 6.2. Use an Allen key to remove the port cap to get access to the restrictor.
  - 6.3. Use an Allen key to remove the restrictor.
  - 6.4. Replace the restrictor with the correct size.  
[Refer to: Technical Data \(PIL 30-00-00\).](#)
  - 6.5. Install the port cap.
  - 6.6. Tighten the port cap.

## Upper Lift Cylinder Control Valve

The double cylinder ram machines are installed with the upper lift cylinder control valve in addition to the lower lift cylinder control valve.

### Remove

1. Make the machine safe with the platform raised.  
[Refer to: PIL 01-03-27.](#)
2. Discharge the hydraulic pressure.  
[Refer to: Discharge and Pressurise \(PIL 30-00-00\).](#)
3. Install the safety strut. Danger or injury will result if the scissor arm is not supported fully.  
[Refer to: PIL 01-03-27.](#)
4. Put a label on the hoses and harness connections to help installation.
5. Disconnect the hydraulic hoses from the main control valve.
6. Disconnect the electrical connections to the sensors.
7. Plug all the open ports and hoses to prevent contamination.
8. Support the valve.
9. Remove the capscrews (x3).
  - 9.1. Carefully remove the capscrews to release any trapped pressure. Take care to avoid any risk of contact with high pressure hydraulic fluid.
10. Remove the lift cylinder control valve.

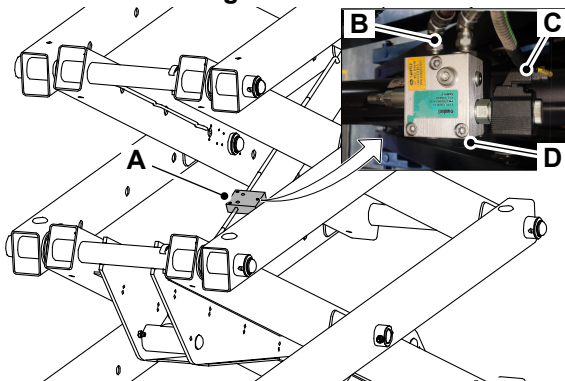
### Install

1. The installation procedure is the opposite of the removal procedure. Additionally do the following steps.
2. Make sure that the contact surfaces are clean.
3. Lightly lubricate all the O-rings. Make sure that all O-rings are correctly seated when assembling.
4. Tighten the screws to the correct torque value.
5. Check the hydraulic fluid level and refill if necessary.  
[Refer to: Check \(Level\) \(PIL 30-00-00\).](#)

**Table 63. Torque Values**

Item	Nm
D	35 ± 3

**Figure 167.**



- A** Lift cylinder control valve (Upper)
- B** Hydraulic hoses
- C** Electrical connections
- D** Capscrews (x3)



## 93 - Hose

### 00 - General

Introduction .....	30-57
Disconnect and Connect .....	30-58
Check (Condition) .....	30-59

### Introduction

Hydraulic hoses are used to connect different components in the hydraulic circuit. The hoses are graded by pressure, temperature, and fluid compatibility. Hoses are built up with rubber and steel layers. A rubber interior is surrounded by multiple layers of woven wire and rubber. The exterior is designed for abrasion resistance. The bend radius of a hydraulic hose is carefully designed for the machine, since hose failures can be deadly, and violating the hose's minimum bend radius will cause failure. Hydraulic hoses generally have steel fittings swaged on the ends.

JCB © CONNOR STANMORE - 13/03/2026 07:57.

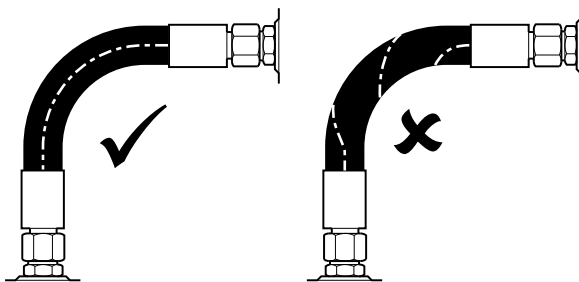
## Disconnect and Connect

Some attachments are hydraulically powered. The following procedures show how to connect and disconnect the hydraulic hoses safely.

### Connecting the Hydraulic Hoses

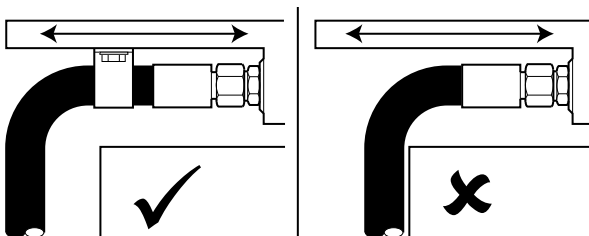
1. Make the machine safe.
2. Discharge the hydraulic system pressure.
3. Check the hoses and adaptors for damage.
4. Connect the hoses:
  - 4.1. Make sure that the hose is not twisted. Pressure applied to a twisted hose can cause the hose to fail or the connections to loosen.

Figure 168.



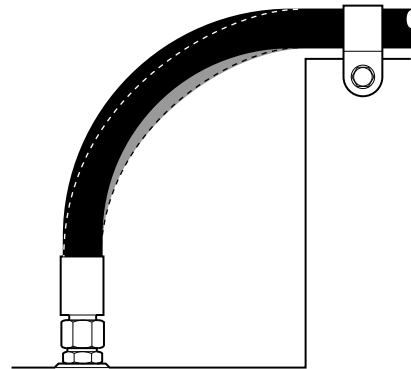
- 4.2. Make sure that the hose does not touch hot parts. High ambient temperatures can cause the hose to fail.
- 4.3. Make sure that the hose does not touch parts which can rub or cause abrasion.
- 4.4. Use the hose clamps (where possible) to support long hose runs and keep the hoses away from moving parts, etc.

Figure 169.



- 4.5. To allow for length changes when the hose is pressurised, do not clamp at the bend. The curve absorbs the change.

Figure 170.



5. Check for leaks:
  - 5.1. Start the machine.
  - 5.2. Operate the related controls to increase the pressure in the hydraulic system.
  - 5.3. Stop the machine then remove the key.
  - 5.4. Check for indications of leakage at the hose connections. Correct, as necessary.

### Disconnecting the Hydraulic Hoses

1. Make the machine safe.
2. Discharge the hydraulic system pressure.
3. Disconnect the hoses.
4. Check the hoses and adaptors for damage.
5. If necessary, install the blanking caps.
6. Check for leaks:
  - 6.1. Start the machine.
  - 6.2. Operate the related controls to increase the pressure in the hydraulic system.
  - 6.3. Stop the machine then remove the key.
  - 6.4. Check for indications of leakage at the hose connections. Correct, as necessary.

## Check (Condition)

### Hydraulic Hoses

**▲ WARNING** Damaged hoses can cause fatal accidents. Examine the hoses regularly. Do not use the machine if a hose or hose fixture is damaged.

**WARNING** Fine jets of fluid at high pressure can penetrate the skin. Keep face and hands well clear of fluid under pressure and wear personal protective equipment. Hold a piece of cardboard close to suspected leaks and then examine the cardboard for signs of fluid. If fluid penetrates your skin, get medical help immediately.

Examine the hoses for:

- Damaged hose ends
- Worn or cracked outer covers
- Ballooned outer covers
- Kinked or crushed hoses
- Exposed armouring in the outer covers
- Displaced hose end fittings.
- Worn cover sheathing or hose burst protection covering

Replace a damaged hose before you use the machine again.

The replacement hoses must be of the same size, standard and pressure rating. If necessary, for more information contact your JCB dealer.

## 97 - Connectors

### 00 - General

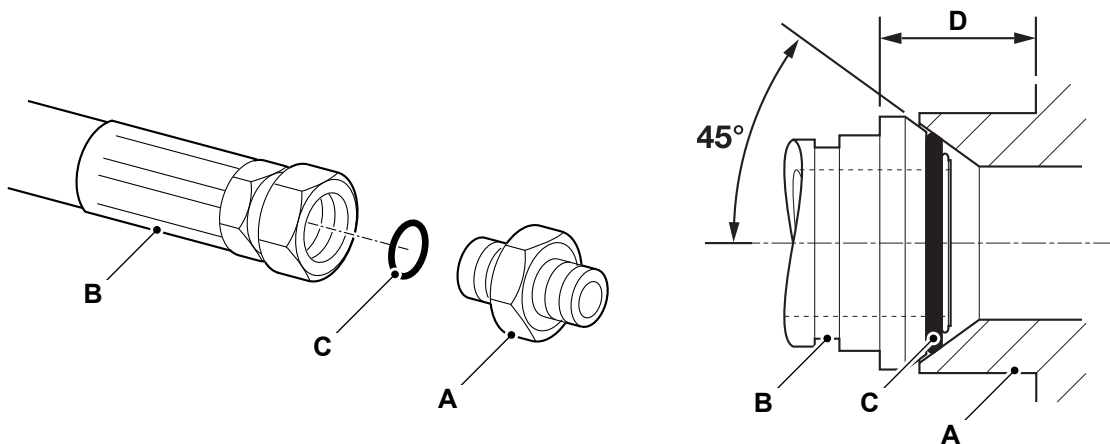
### Technical Data

#### Adaptors Connected into Valve Blocks

**Table 64. Torque Settings - BSP Adaptors**

BSP Adaptor Size Inch	BSP Adaptor Size mm	Hexagon (A/F) mm	Torque Value N·m
1/4	6.35	19mm	18N·m
3/8	9.525	22mm	31N·m
1/2	12.7	27mm	49N·m
5/8	15.875	30mm	60N·m
3/4	19.05	32mm	81N·m
1	25.4	38mm	129N·m
1 1/4	31.75	50mm	206N·m

#### Hoses installed into Adaptors

**Figure 171.**


**A** Adaptor  
**C** O-ring

**B** Hose  
**D** Dimension will vary depending upon the torque applied.

Hoses installed into adaptors seal onto an O-ring which is compressed into a 45° seat machined into the face of the adaptor port.



Table 65. Torque Settings - Metric Adaptors

Adaptor specification	Torque
M10	13–17N·m
M12	22–28N·m
M14	31–39N·m
M16	36–44N·m
M18	40–50N·m
M22	54–66N·m

JCB © CONNOR STANMORE - 13/03/2026 07:57.



---

Notes:

---

---

---

---

---

---

---

---

---

---

---

---

---

---

---

---

---

---

---

---

---

---

---

---

---



# 33 - Electrical System

Contents	Page No.
Acronyms Glossary .....	33-3
33-00 Electrical System	
33-00-00 General .....	33-4
33-00-50 Schematic Circuit .....	33-15
33-00-95 Equipotential Bonding .....	33-126
33-03 Battery	
33-03-00 General .....	33-128
33-04 Battery Charger	
33-04-00 General .....	33-141
33-05 Battery Quick Disconnect	
33-05-00 General .....	33-153
33-07 DC Contactor	
33-07-00 General .....	33-155
33-09 Power Distribution	
33-09-00 General .....	33-158
33-09-03 Fuse .....	33-160
33-09-06 Relay .....	33-164
33-10 Motor	
33-10-00 General .....	33-165
33-12 Harness	
33-12-00 General .....	33-169
33-15 Alarm	
33-15-00 General .....	33-179
33-24 Instruments	
33-24-04 Control Panel .....	33-181
33-24-05 Platform Controller .....	33-184
33-36 Horn	
33-36-00 General .....	33-196
33-42 Exterior Light	
33-42-39 Hazard Warning Light .....	33-199
33-45 Control Module	
33-45-03 Machine Control .....	33-201
33-45-66 Motor Controller .....	33-203
33-57 Electronic Diagnostic	
33-57-03 Servicemaster .....	33-210
33-57-90 Error Codes .....	33-215
33-84 Sensor	
33-84-00 General .....	33-216
33-84-07 Hydraulic Pressure .....	33-218
33-84-60 Tilt .....	33-220
33-84-63 Angle .....	33-222
33-84-82 Pothole Protection System .....	33-225
33-84-84 Platform Upper Limit .....	33-228



---

33-84-85 Platform Down Limit .....	33-231
33-86 Solenoid	
33-86-00 General .....	33-234
33-95 AC Circuit	
33-95-09 Residual Current Circuit Breaker with Overcurrent protection (RCBO) .....	33-236
33-95-75 AC Connector .....	33-239



---

## Acronyms Glossary

AC	Alternating Current
CAN	Controller Area Network
DC	Direct Current
DLA	Data Link Adaptor
ECM	Engine Control Module
ECU	Electronic Control Unit
LED	Light Emitting Diode
MECU	Machine Electronic Control Unit
RCBO	Residual Current Breaker with Over-Current
RPM	Revolutions Per Minute
USB	Universal Serial Bus

JCB © CONNOR STANMORE - 13/03/2026 07:57.



## 00 - Electrical System

### 00 - General

Introduction .....	33-4
Health and Safety .....	33-5
Technical Data .....	33-6
Operation .....	33-11
Fault-Finding .....	33-12
Diagram .....	33-13
Check (Condition) .....	33-14
Check (Operation) .....	33-14

### Introduction

It is important that the electrical system on the machine is in a sound state of repair.

Make sure that all the health and safety warnings in this section are followed. The machine must be safe with the battery isolated before you attempt to disconnect any electrical connections.

JCB © CONNOR STANMORE - 13/03/2026 07:57.

## Health and Safety

▲ **WARNING** Do not connect the charger when the batteries are not connected. Doing so could result in danger of live terminals from the charger.

Do not carry out maintenance on a machine whilst the charger is connected to an external power supply (i.e. do not work on a live machine). Cables from the charger to the batteries may remain live even if the batteries are disconnected/removed from the machine. There is a risk of serious electrical shock.

Always disconnect all external power supplies to the machine before carrying out maintenance.

**CAUTION** Understand the electrical circuit before connecting or disconnecting an electrical component. A wrong connection can cause injury and/or damage.

## Technical Data

For: S1932E EDRV [RAJ], S2632E EDRV [RAJ] ..... Page 33-6

For: S2646E EDRV [RAJ], S3246E EDRV [RAJ] ..... Page 33-7

For: S4046E EDRV [RAJ], S4550E EDRV [RAJ] ..... Page 33-9

(For: S1932E EDRV [RAJ], S2632E EDRV [RAJ])

**Table 66. Trojan Battery**

Description	Data
Battery	
Make	Trojan Battery Company
Model	T-105
Quantity	4
Voltage	6V
Operating temperature	-20–45°C (-4.0–112.9°F) <sup>(1)</sup>
Capacity Rating <sup>(4)</sup>	5h - 185 Ah
	10h - 207 Ah
	20h - 225 Ah
	100h - 250 Ah
Weight <sup>(5)</sup>	28kg
Battery Charge Voltage <sup>(2, 3)</sup>	
Bulk Charge	7.4V
Float Charge	6.7V
Equalize Charge	8.1V

(1) At temperatures below 0°C (32.0°F) maintain a state of charge greater than 60%.

(2) Add 0.005V per cell for every 1°C (33.8°F) below 25°C (77.0°F).

(3) Subtract 0.005V per cell for every 1°C (33.8°F) above 25°C (77.0°F).

(4) The amount of amp-hours (AH) a battery can deliver when discharged at a constant rate at 27°C (80.6°F) and maintain a voltage above 1.7V per cell. Capacities are based on peak performance.

(5) If you replace the batteries, make sure that new batteries are of same weight to avoid stability issues.

**Table 67. Control Motor**

Description	Data
Type	Series wound, DC (Direct Current) electric motor
Rated power	3.3kW
Input voltage	24V
Rated current	180A
Rated speed	3050RPM
Maximum speed	5600RPM

**Table 68. AGM Battery - 6V (Optional)**

Specification	Technical Data
Battery	
Make	AGM
Number of cell	3
Nominal voltage	6Veach
Capacity rating <sup>(1)</sup>	1h - 130Ah



Specification	Technical Data
	2h - 155Ah
	3h - 175Ah
	5h - 190Ah
	10h - 210Ah
	20h - 220Ah
Weight <sup>(2)</sup>	30kg
Minutes discharge at 27°C (80.6°F)	25AF.V (1.75/Cell) -460min 75AF.V (1.75/Cell) -120min
Internal resistance	Fully charged battery 25°C (77.0°F) - ≤2 mOhms
Self discharge	3% of capacity per month at 20°C (68.0°F)(average)
Cranking amps	0°C (32.0°F) - 1430 -18°C (-0.4°F) - 1100
Maximum discharge current 25°C (77.0°F)	1,650A5s
Charge methods: constant voltage charge 25°C (77.0°F)	
Cycle use	2.4V-2.45VPC
Initial charging current	66A
Float use	2.2V-2.3VPC
Charger output DC current	30A
Average battery charging time	8h

(1) The amount of amp-hours (AH) a battery can deliver when discharged at a constant rate at 25°C (77°F) and maintain a voltage 1.75V per cell. Capacities are based on peak performance.

(2) If you replace the batteries, make sure that new batteries are of same weight to avoid stability issues.

(For: S2646E EDRV [RAJ], S3246E EDRV [RAJ])

Table 69. Trojan Battery

Description	Data
Battery	
Make	Trojan Battery Company
Model	T-125
Quantity	4
Voltage	6V
Operating temperature	-20–45°C (-4.0–112.9°F) <sup>(1)</sup>
Capacity Rating <sup>(4)</sup>	5h - 195 Ah 10h - 221 Ah 20h - 240 Ah 100h - 266 Ah
Weight <sup>(5)</sup>	30kg
Battery Charge Voltage <sup>(2, 3)</sup>	
Bulk Charge	7.4V

Description	Data
Float Charge	6.7V
Equalize Charge	8.1V

(1) At temperatures below 0°C (32.0°F) maintain a state of charge greater than 60%.

(2) Add 0.005V per cell for every 1°C (33.8°F) below 25°C (77.0°F).

(3) Subtract 0.005V per cell for every 1°C (33.8°F) above 25°C (77.0°F).

(4) The amount of amp-hours (AH) a battery can deliver when discharged at a constant rate at 27°C (80.6°F) and maintain a voltage above 1.7V per cell. Capacities are based on peak performance.

(5) If you replace the batteries, make sure that new batteries are of same weight to avoid stability issues.

**Table 70. Control Motor**

Description	Data
Type	Series wound,DC electric motor
Rated power	3.3kW
Input voltage	24V
Rated current	180A
Rated speed	3050RPM
Maximum speed	5600RPM

**Table 71. AGM Battery - 6V (Optional)**

Specification	Technical Data
Battery	
Make	AGM
Number of cell	3
Nominal voltage	6Veach
Capacity rating <sup>(1)</sup>	1h - 130Ah
	2h - 155Ah
	3h - 175Ah
	5h - 190Ah
	10h - 210Ah
	20h - 220Ah
Weight <sup>(2)</sup>	30kg
Minutes discharge at 27°C (80.6°F)	25AF.V (1.75/Cell) -460min 75AF.V (1.75/Cell) -120min
Internal resistance	Fully charged battery25°C (77.0°F) - ≤2 mOhms
Self discharge	3% of capacity per month at 20°C (68.0°F)(average)
Cranking amps	0°C (32.0°F) - 1430 -18°C (-0.4°F) - 1100
Maximum discharge current 25°C (77.0°F)	1,650A5s
Charge methods: constant voltage charge25°C (77.0°F)	
Cycle use	2.4V-2.45VPC
Initial charging current	66A
Float use	2.2V-2.3VPC



Specification	Technical Data
Charger output DC current	30A
Average battery charging time	8h

(1) The amount of amp-hours (AH) a battery can deliver when discharged at a constant rate at 25°C (77°F) and maintain a voltage 1.75V per cell. Capacities are based on peak performance.

(2) If you replace the batteries, make sure that new batteries are of same weight to avoid stability issues.

(For: S4046E EDRV [RAJ], S4550E EDRV [RAJ])

**Table 72. Trojan Battery**

Description	Data
Battery	
Make	Trojan Battery Company
Model	T-1275
Quantity	4
Voltage	12V
Operating temperature	-20–45°C (-4.0–112.9°F) <sup>(1)</sup>
Capacity Rating <sup>(4)</sup>	5h - 120 Ah
	10h - 134 Ah
	20h - 150 Ah
	100h - 166 Ah
Weight <sup>(5)</sup>	39kg
Battery Charge Voltage <sup>(2, 3)</sup>	
Bulk Charge	14.8V
Float Charge	13.5V
Equalize Charge	16.2V

(1) At temperatures below 0°C (32.0°F) maintain a state of charge greater than 60%.

(2) Add 0.005V per cell for every 1°C (33.8°F) below 25°C (77.0°F).

(3) Subtract 0.005V per cell for every 1°C (33.8°F) above 25°C (77.0°F).

(4) The amount of amp-hours (AH) a battery can deliver when discharged at a constant rate at 27°C (80.6°F) and maintain a voltage above 1.7V per cell. Capacities are based on peak performance.

(5) If you replace the batteries, make sure that new batteries are of same weight to avoid stability issues.

**Table 73. Control Motor**

Description	Data
Type	Series wound,DC electric motor
Rated power	4.5kW
Input voltage	24V
Rated current	239A
Rated speed	2700RPM
Maximum speed	5600RPM

**Table 74. AGM Battery - 12V (Optional)**

Specification	Technical Data
Battery	
Make	AGM
Nominal voltage	12Veach
Capacity rating <sup>(1)</sup>	3h - 91.8Ah
	5h - 120Ah



Specification	Technical Data
	10h - 130Ah
	20h - 155Ah
Weight <sup>(2)</sup>	40.6kg
Minutes of discharge	at 25A280min
	at 75A65min
Internal resistance	Fully charged at 20°C (68.0°F) - 3.5 mOhms
Self discharge	<3 of capacity per month at 20°C (68.0°F)
R/C at 25	310
Cranking amps	0°C (32.0°F) - 750
	-18°C (-0.4°F) - 600
Operating temperature range	
Discharge	-20°C (-4.0°F)~60°C (139.9°F)
Charge	-10°C (14.0°F)~60°C (139.9°F)
Storage	-20°C (-4.0°F)~60°C (139.9°F)
Short circuit current	3,800A
Charge methods: constant voltage charge at 20°C (68.0°F)	
Standby use	
Maximum charging current	0.3C10A
Charge voltage	13.6V-13.8V
Temperature compensation	-20mV/°C
Cyclic use	
Maximum charging current	0.3C10A
Charge voltage	14.4V-14.7V
Temperature compensation	-30mV/°C
Charger output DC current	30A
Average battery charging time	8h

(1) The amount of amp-hours (AH) a battery can deliver when discharged at a constant rate at 25°C (77°F) and maintain a voltage 1.75V per cell. Capacities are based on peak performance.

(2) If you replace the batteries, make sure that new batteries are of same weight to avoid stability issues.

## Operation

The main components of the electrical system are:

- Motor.  
[Refer to: PIL 33-10-00.](#)
- Motor controller ECU (Electronic Control Unit).  
[Refer to: PIL 33-45-66.](#)
- MECU (Machine Electronic Control Unit).  
[Refer to: PIL 33-45-03.](#)
- Batteries.  
[Refer to: PIL 33-03-00.](#)
- Battery charger.  
[Refer to: PIL 33-04-00.](#)
- Sensors.  
[Refer to: PIL 33-84-00.](#)
- Ground control panel.  
[Refer to: PIL 33-24-04.](#)
- Platform control panel.  
[Refer to: PIL 33-24-05.](#)

The batteries drive the electrical pump motor, which drives the gear pump to provide necessary hydraulic power. The electrical power required to operate the controls and other electrical components is also taken from the batteries.

## Fault-Finding

### Fault

Battery fault

General Relay Fault

Electrical Wiring

Table 74.

Page 33-12

Table 74.

Page 33-12

Table 74.

Page 33-12

**Table 74. Battery fault**

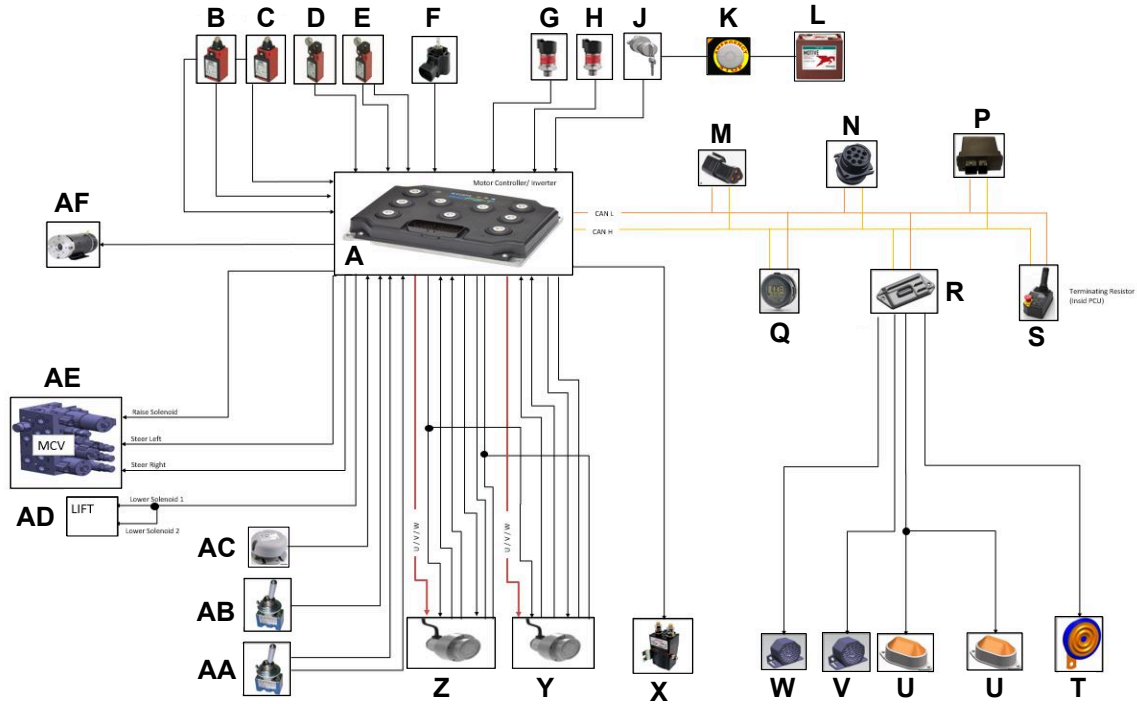
Cause	Remedy
Battery Voltage	Switch on the ignition key and check the battery voltage with a multimeter. If the battery voltage is below specified value, charge the batteries. <a href="#">Refer to: Check (Level) (PIL 33-03-00).</a>
Battery connection fault	Check the condition of the electrical wires to the battery. Check for signs of corrosion or contamination on the battery terminals. Clean the battery terminals. Repair as necessary.
Battery charge circuit fault	Make sure that the AC (Alternating Current) supply to the battery charger is ON. Check the connections to the battery charger. Make sure that the correct charger profile is loaded into the charger. <a href="#">Refer to: Calibrate (PIL 33-04-00).</a> If no fault is found raise a Techweb Helpdesk call.

**Table 74. General Relay Fault**

Cause	Remedy
Relay supply voltage fault	Check the condition of the primary and secondary fuses. If relay supply voltage is found fault, proceed to 'Relay connection faulty'. If relay supply voltage is OK, raise Techweb Helpdesk Call.
Relay connection faulty	Check the condition of relay to harness connection. Repair/replace as necessary.

**Table 74. Electrical Wiring**

Cause	Remedy
Wiring fault	Check the harness continuity and electrical insulation, repair or replace as necessary.

**Diagram**
**Figure 172. Typical Machine**


- |           |                            |           |   |
|-----------|----------------------------|-----------|---|
| <b>A</b>  | Motor controller/ Inverter | <b>B</b>  | LH pothole switch                           |
| <b>C</b>  | RH pothole switch          | <b>D</b>  | Up limit switch                             |
| <b>E</b>  | Down limit switch          | <b>F</b>  | Angle sensor                                |
| <b>G</b>  | Pressure sensor 1          | <b>H</b>  | Pressure sensor 2                           |
| <b>J</b>  | Ignition key               | <b>K</b>  | Emergency stop                              |
| <b>L</b>  | Battery                    | <b>M</b>  | Terminating resistor                        |
| <b>N</b>  | Diagnostic                 | <b>P</b>  | Livelink 4                                  |
| <b>Q</b>  | Base display               | <b>R</b>  | I/O Expansion ECU (Electronic Control Unit) |
| <b>S</b>  | Platform controller        | <b>T</b>  | Horn  |
| <b>U</b>  | Flash light                | <b>V</b>  | Buzzer                                      |
| <b>W</b>  | White noise alarm (option) | <b>X</b>  | DC Contractor cell                          |
| <b>Y</b>  | Wheel drive motor left     | <b>Z</b>  | Wheel drive motor right                     |
| <b>AA</b> | Toggle up/down switch      | <b>AB</b> | Enable switch                               |
| <b>AC</b> | Tilt switch                | <b>AD</b> | Lift  |
| <b>AE</b> | Main control valve         | <b>AF</b> | DC (Direct Current) motor                   |

## Check (Condition)

Examine the electrical circuits regularly for:

- Damaged connectors.
- Loose connections.
- Chafing on the wiring harnesses.
- Corrosion.
- Missing insulation.
- Incorrect routing of the wiring harnesses.

Do not use the machine if one or more of these faults are found. You must make sure that the electrical circuit is repaired immediately.

## Check (Operation)

Make sure that all the electrical equipment listed below operate correctly.

- Switches (Limit switch and Tilt switch).
- Warning lights.
- Alarm.
- Horn.
- Hourmeter.
- Battery.
- Lights.
- Sensors (Angle sensor and Pressure sensor).
- Controllers.
- Pothole protection system.

All defective equipment must be repaired before the machine is used.

Use the correct diagnostic tool to check the proper operation of the sensors.



## 50 - Schematic Circuit

Introduction ..... 33-15  
 Diagram ..... 33-18

## Introduction

A schematic wiring diagram is a simplified pictorial representation of the machines electrical circuit. It shows the components of the circuit as simplified electrical symbols, and the power and signal connections between the devices. The wiring diagram is used to troubleshoot problems and to make sure that all the connections have been made and that everything is present.

Use the schematics together with the correct electrical harness drawings to reference the connector pin details.

This section may contain more than one set of electrical schematics for different machine variants.

### Understanding Electrical Schematics

Use the applicable schematic set to trace wires and connections between electrical devices. In most cases it will be necessary to trace wires across more than one schematic sheet.

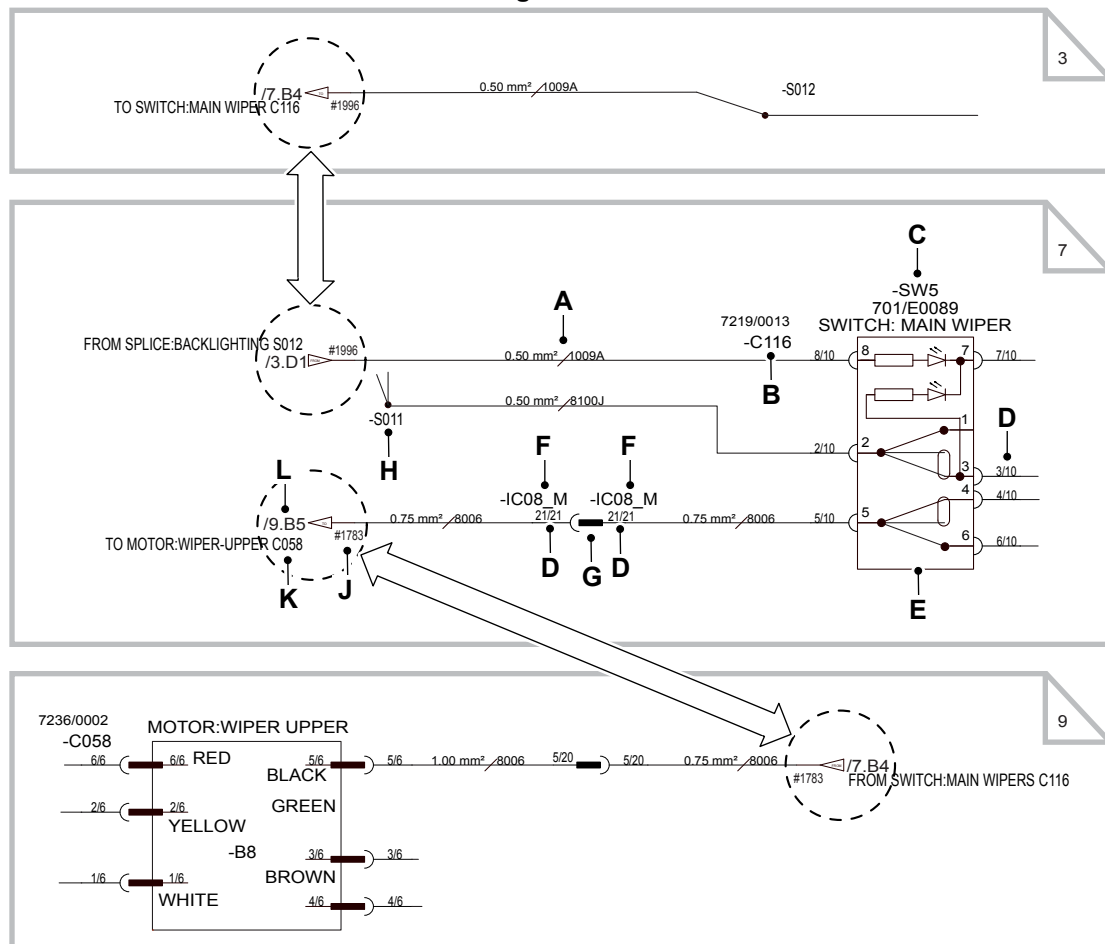
The example identifies the information contained on the diagrams. It also shows how to follow wires from one diagram sheet to another.

The harness inter-connector codes and device harness connector codes are the same as used on the applicable harness drawings.

Splices are not normally accessible. Splices are inside the harness sheath and not visible on the outside. Wires are welded together at a splice, there are no individual connector components.

JCB © CONNOR STANMORE - 13/03/2026 07:57.

**Figure 173.**



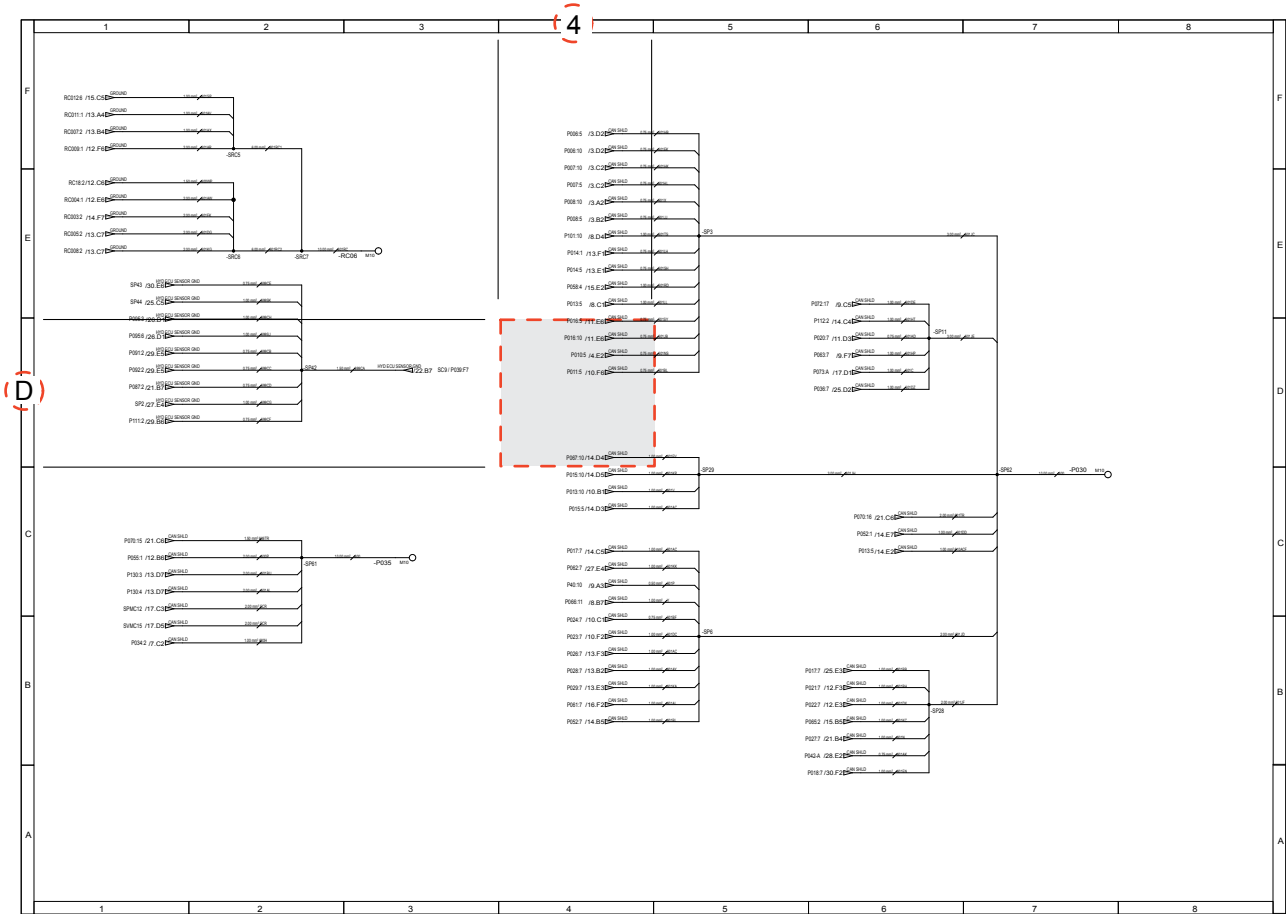
- A** Wire size (area) and number
- C** Device description
- E** Device internal schematic
- G** Harness inter-connector symbol
- J** Destination reference number
- L** Destination (diagram sheet and grid)

- B** Device harness connector code
- D** Connector pin number (wire location / total)
- F** Harness inter-connector codes
- H** Splice code and symbol
- K** Destination (harness connector code)

To help locate a wire destination from other diagram sheets use the grid reference. This identifies the applicable location zone on the sheet in a similar way to a map reference.

Due to space limitations, the grid is sometimes omitted.

Figure 174. Grid reference example (D4)



JCB © CONNOR STANMORE - 13/03/2026 07:57.



## Diagram

For: S1932E EDRV [RAJ], S2632E EDRV [RAJ], S2646E EDRV [RAJ] ..... Page 33-18

For: S3246E EDRV [RAJ], S4046E EDRV [RAJ], S4550E EDRV [RAJ] ..... Page 33-70

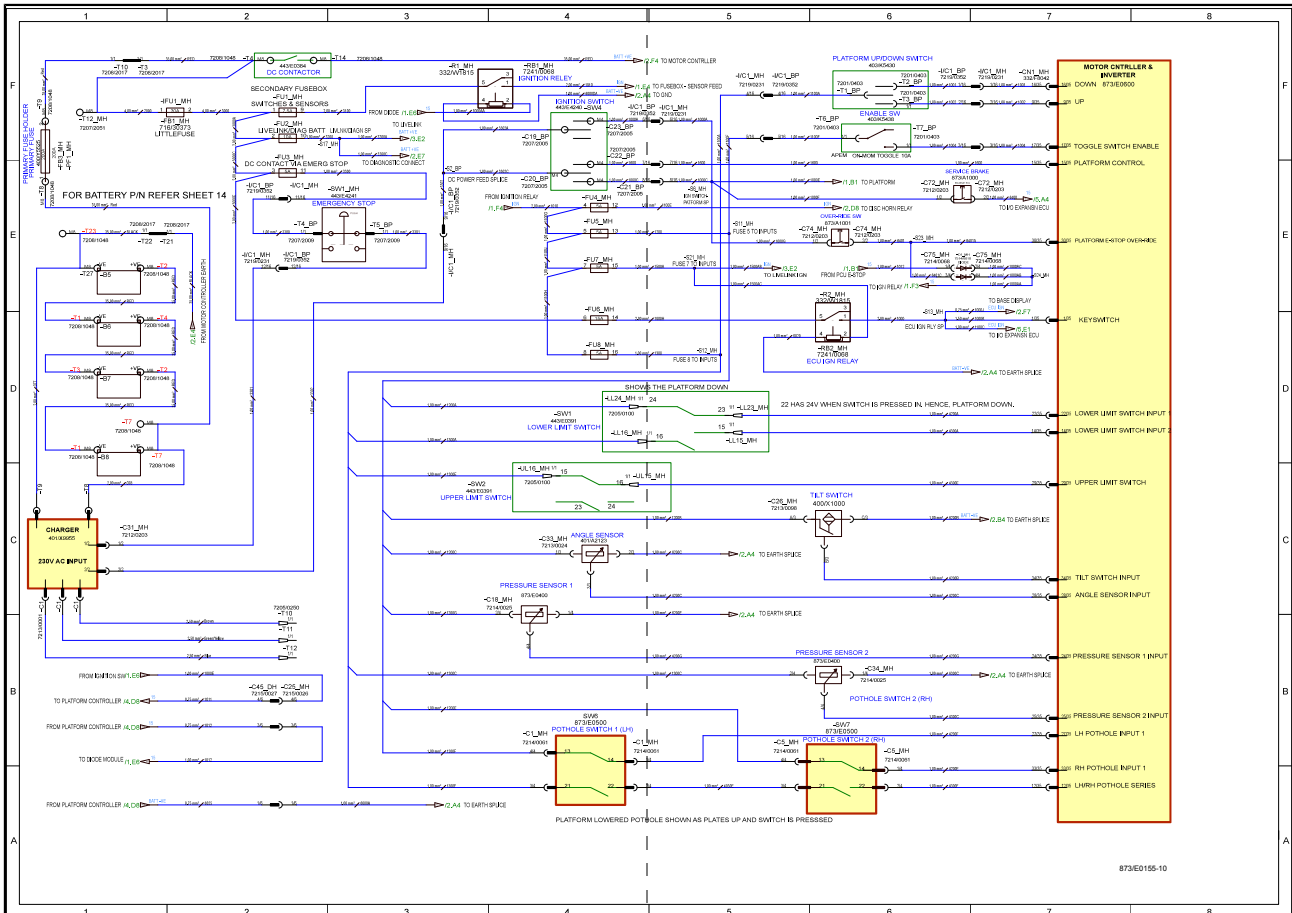
(For: S1932E EDRV [RAJ], S2632E EDRV [RAJ], S2646E EDRV [RAJ])

Figure 175. 873/E0155 Issue 10 (Sheet 1 of 14) - Electric Drive Scissors Schematic.....	Page 33-19
Figure 176. 873/E0155 Issue 10 (Sheet 2 of 14) - Electric Drive Scissors Schematic.....	Page 33-23
Figure 177. 873/E0155 Issue 10 (Sheet 3 of 14) - LiveLink ECU.....	Page 33-27
Figure 178. 873/E0155 Issue 10 (Sheet 4 of 14) - CAN Network.....	Page 33-31
Figure 179. 873/E0155 Issue 10 (Sheet 5 of 14) - Dual Zone.....	Page 33-35
Figure 180. 873/E0155 Issue 10 (Sheet 6 of 14) - Over Rise Protection.....	Page 33-39
Figure 181. 873/E0155 Issue 10 (Sheet 7 of 14) - Power to Platform EU.....	Page 33-43
Figure 182. 873/E0155 Issue 10 (Sheet 8 of 14) - Power to Platform UK.....	Page 33-47
Figure 183. 873/E0155 Issue 10 (Sheet 9 of 14) - Power to Platform UK W/O RCCBO.....	Page 33-51
Figure 184. 873/E0155 Issue 10 (Sheet 10 of 14) - Power to Platform US.....	Page 33-55
Figure 185. 873/E0155 Issue 10 (Sheet 11 of 14) - Power to Platform US W/O MCB.....	Page 33-59
Figure 186. 873/E0155 Issue 10 (Sheet 12 of 14) - Power to Platform SCHUKO.....	Page 33-63
Figure 187. 873/E0155 Issue 10 (Sheet 13 of 14) - Isolator Battery Cable.....	Page 33-67

Sheet 14 is not included as it only contains change log.

JCB © CONNOR STANMORE - 13/03/2026 07:57.

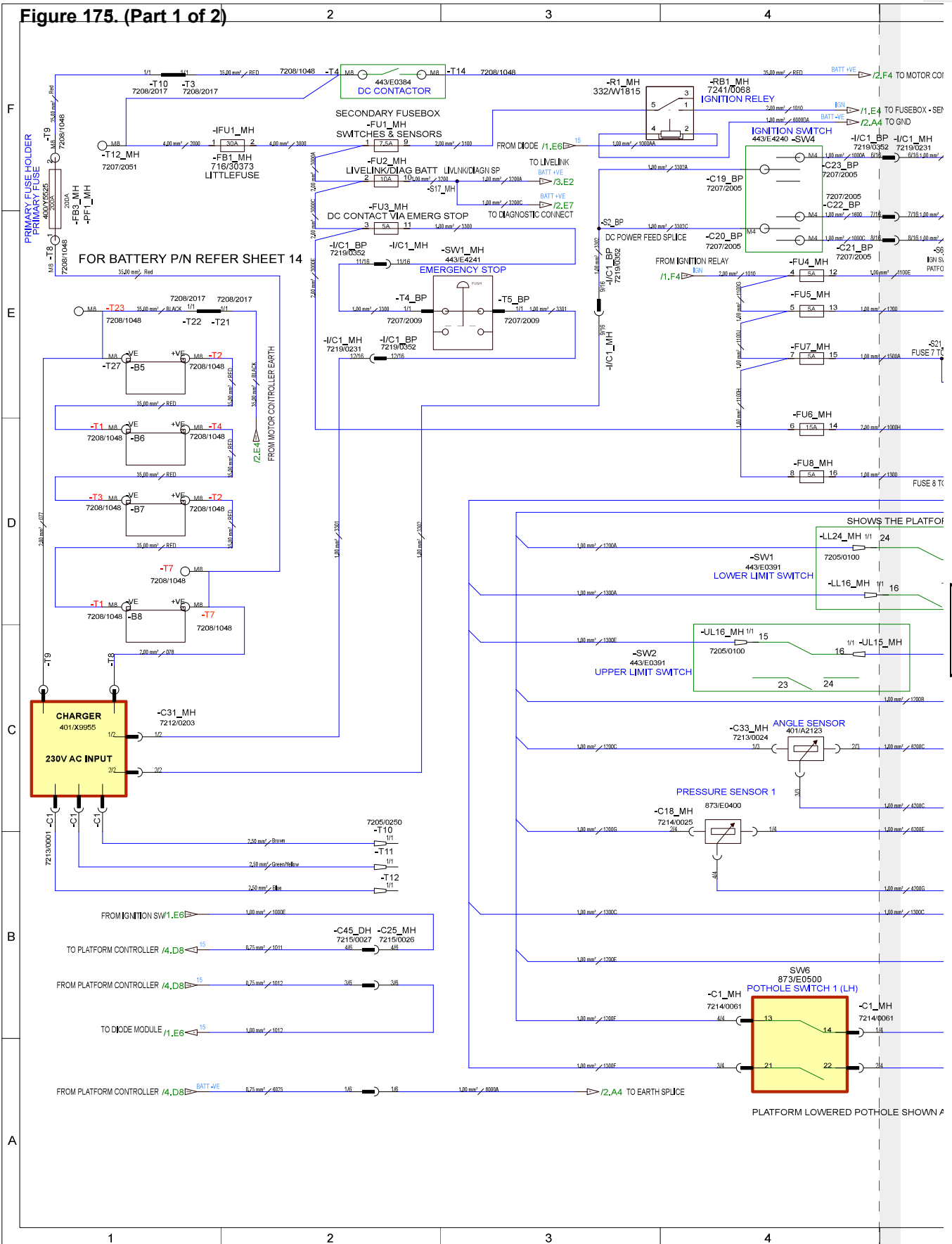
**Figure 175. 873/E0155 Issue 10 (Sheet 1 of 14) - Electric Drive Scissors Schematic**



JCB © CONNOR STANMORE - 13/03/2026 07:57.

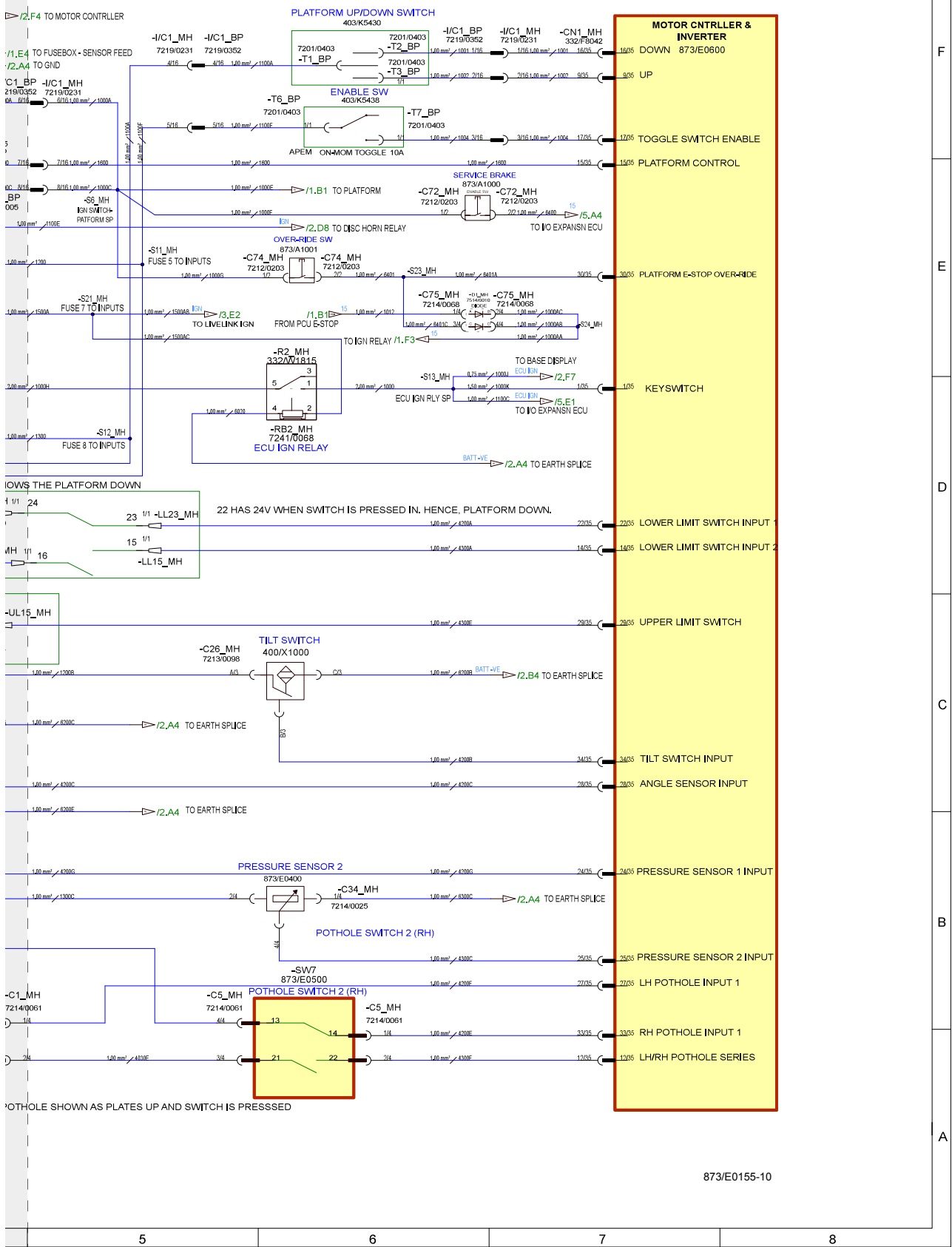


Figure 175. (Part 1 of 2)



Page 33-21

**Figure 175. (Part 2 of 2)**



JCB © CONNOR STANMORE - 13/03/2026 07:57.

Page 33-20



## 33 - Electrical System

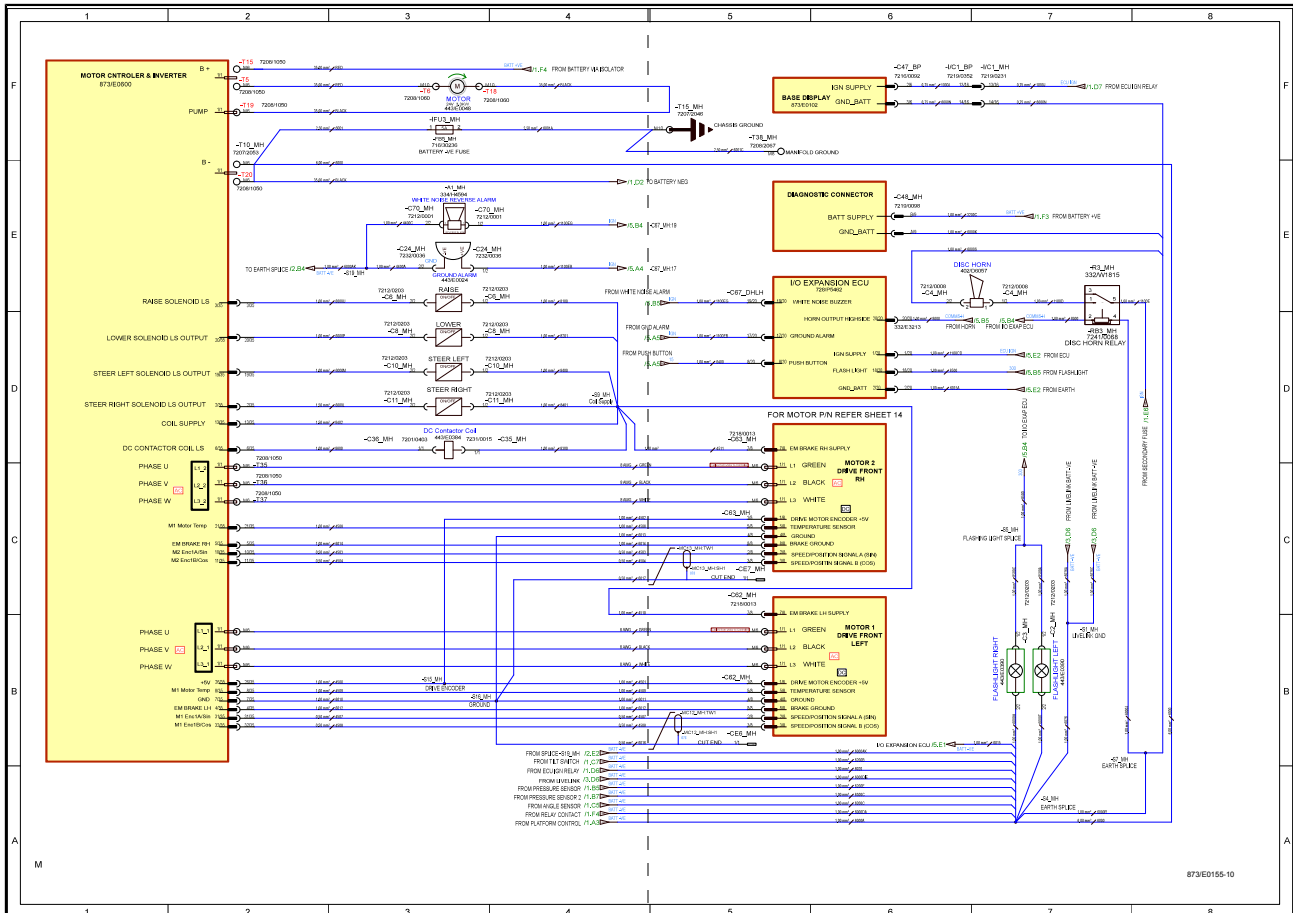
00 - Electrical System

50 - Schematic Circuit

---

JCB © CONNOR STANMORE - 13/03/2026 07:57.

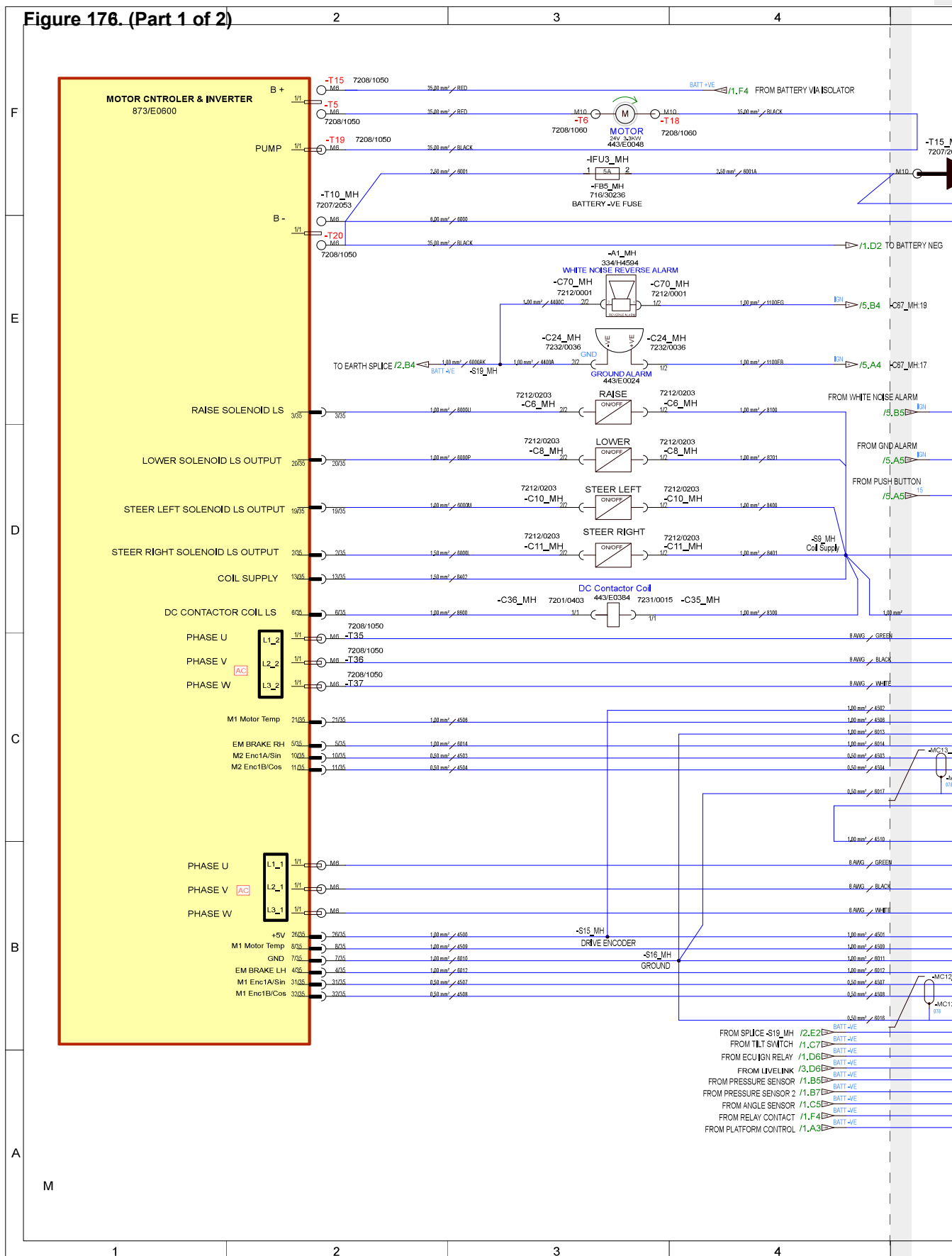
Figure 176. 873/E0155 Issue 10 (Sheet 2 of 14) - Electric Drive Scissors Schematic



873E0155-10

JCB © CONNOR STANMORE - 13/03/2026 07:57.

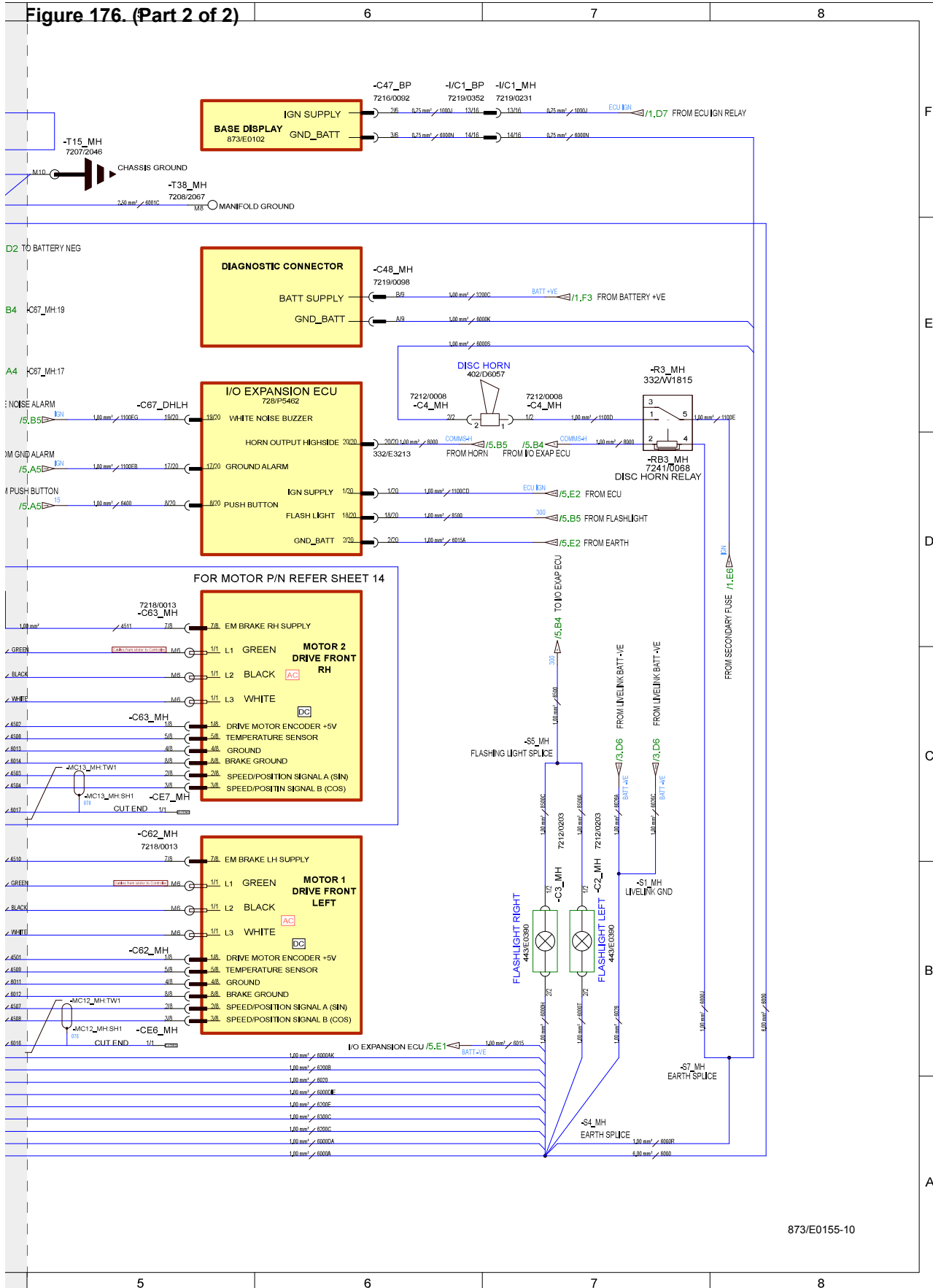
Figure 176. (Part 1 of 2)



Page 33-25

JCB © CONNOR STANMORE - 13/03/2026 07:57.

Figure 176. (Part 2 of 2)



873/E0155-10

JCB © CONNOR STANMORE - 13/03/2026 07:57.

Page 33-24



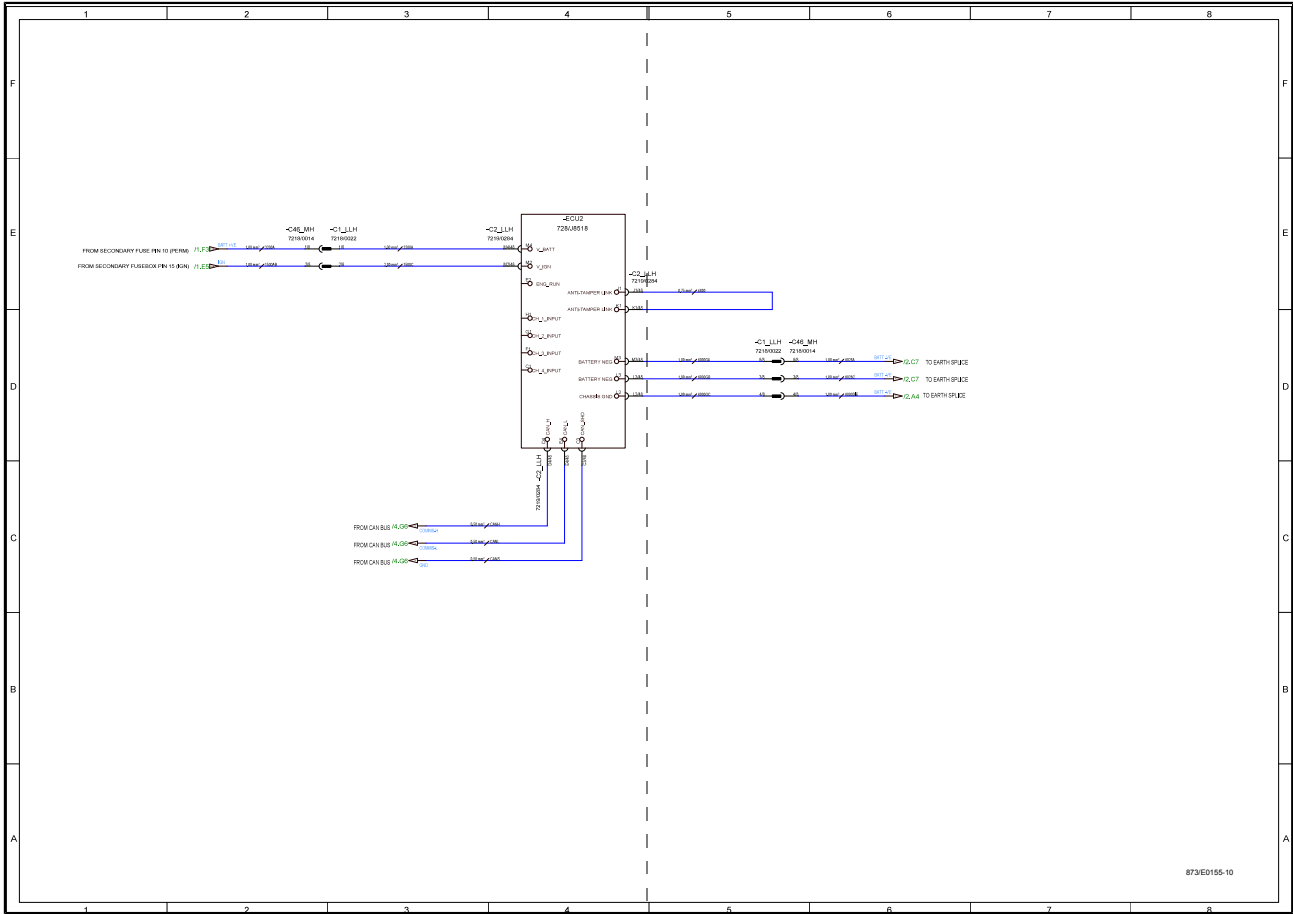
## 33 - Electrical System

00 - Electrical System

50 - Schematic Circuit

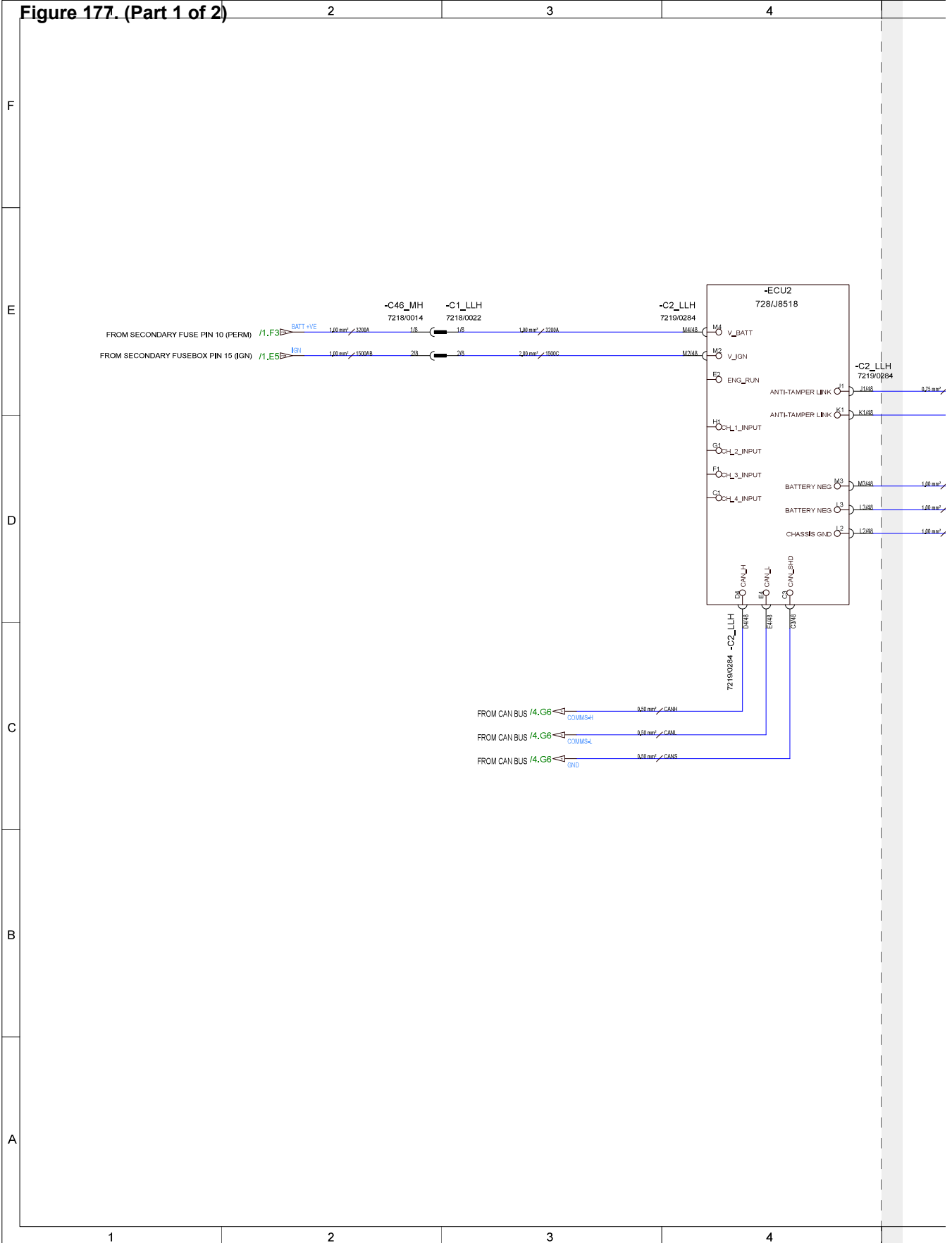
---

JCB © CONNOR STANMORE - 13/03/2026 07:57.



JCB © CONNOR STANMORE - 13/03/2026 07:57.

Figure 177. (Part 1 of 2)

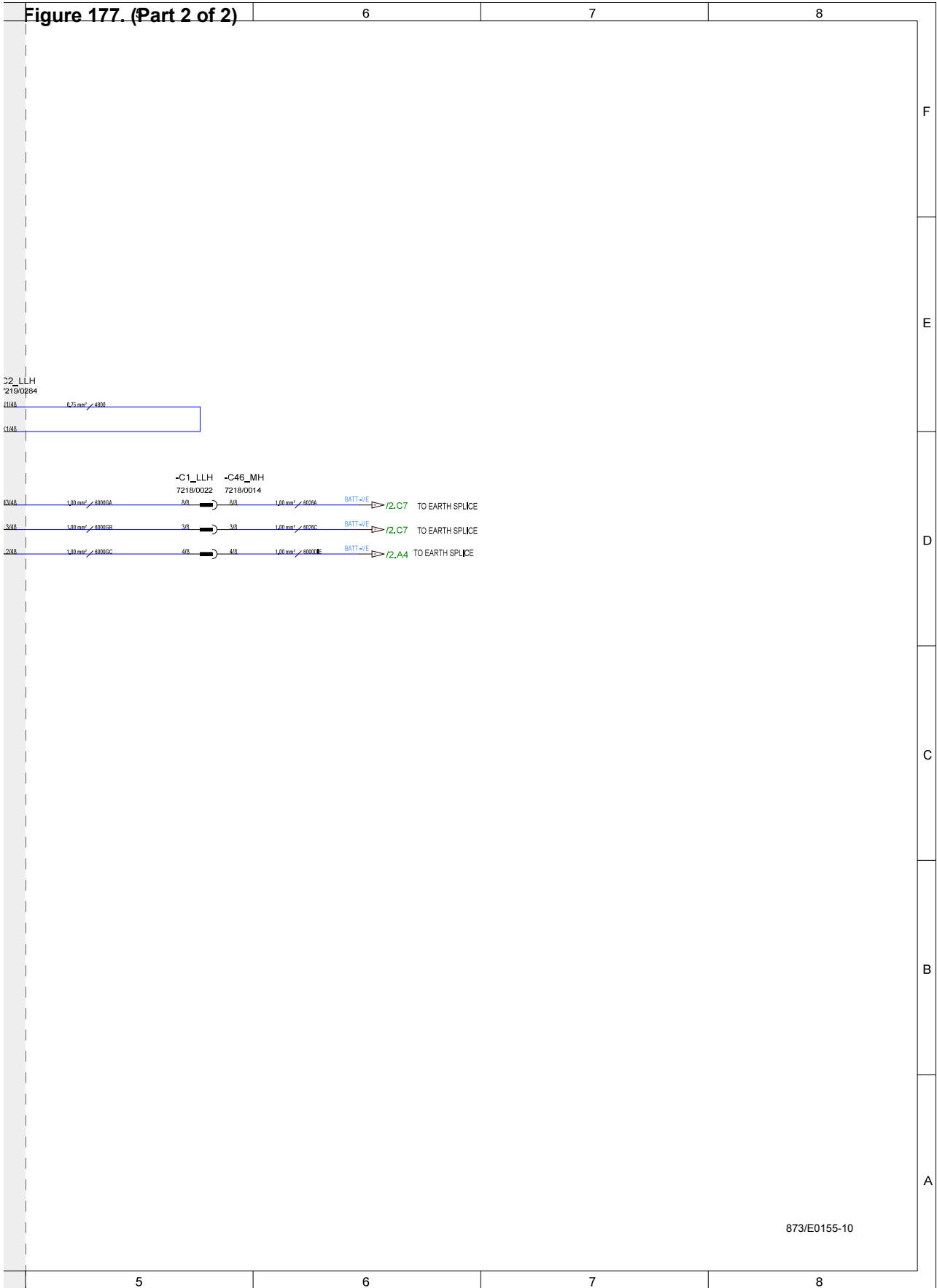


Page 33-29

JCB © CONNOR STANMORE - 13/03/2026 07:57.



Figure 177. (Part 2 of 2)



Page 33-28

JCB © CONNOR STANMORE - 13/03/2026 07:57.

873/E0155-10



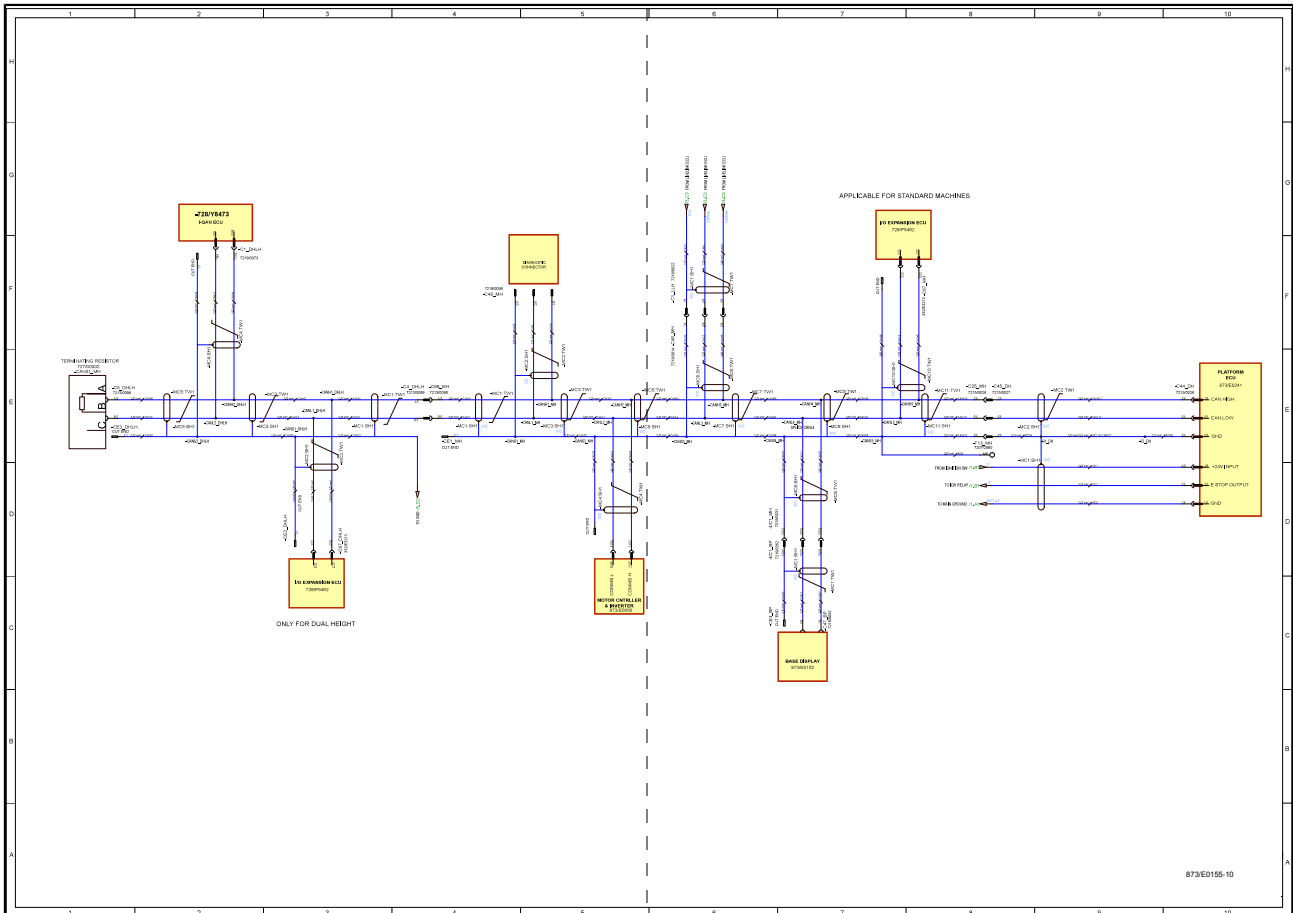
## 33 - Electrical System

00 - Electrical System

50 - Schematic Circuit

---

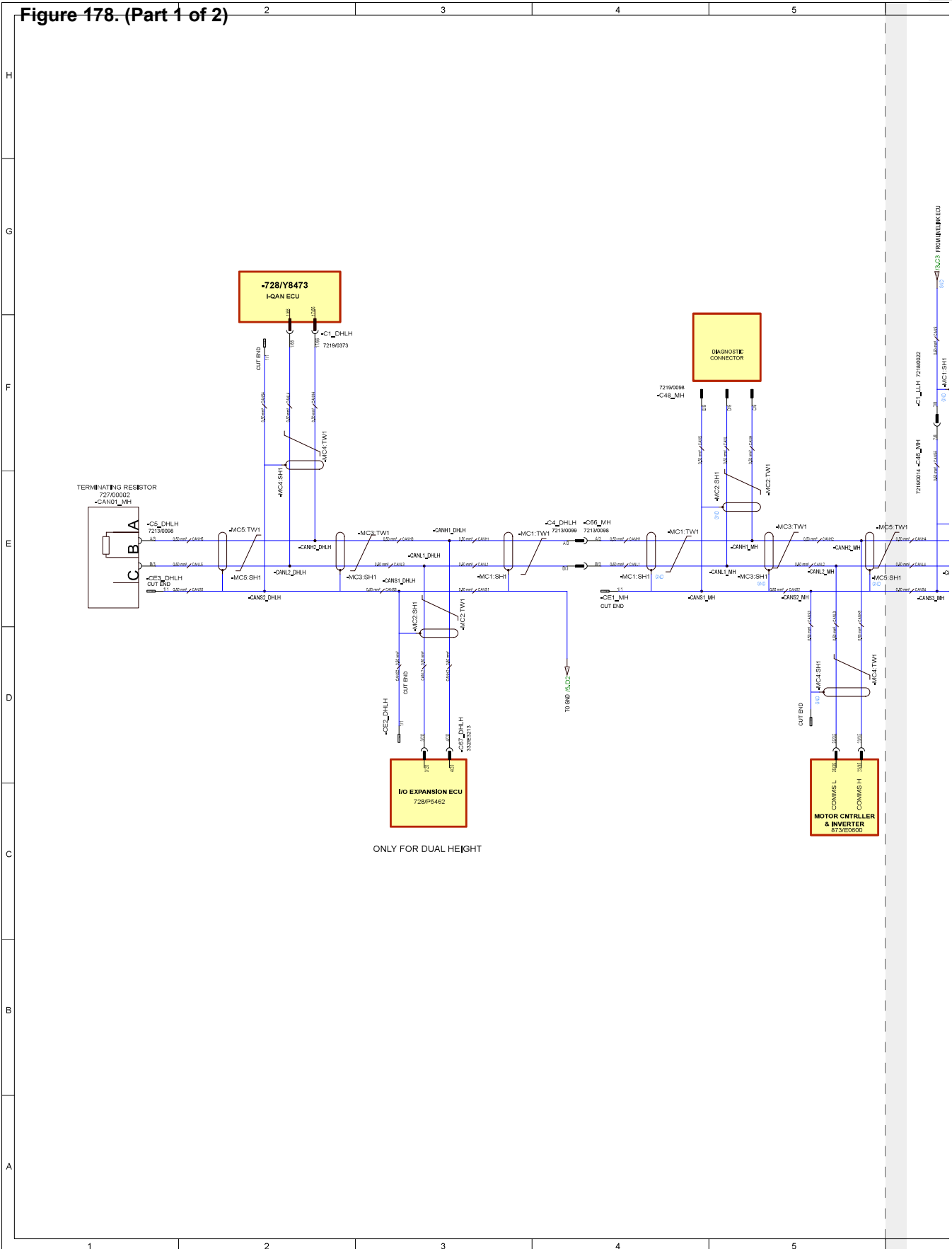
JCB © CONNOR STANMORE - 13/03/2026 07:57.



873/E0155-10

JCB © CONNOR STANMORE - 13/03/2026 07:57.

**Figure 178. (Part 1 of 2)**



Page 33-33

JCB © CONNOR STANMORE - 13/03/2026 07:57.





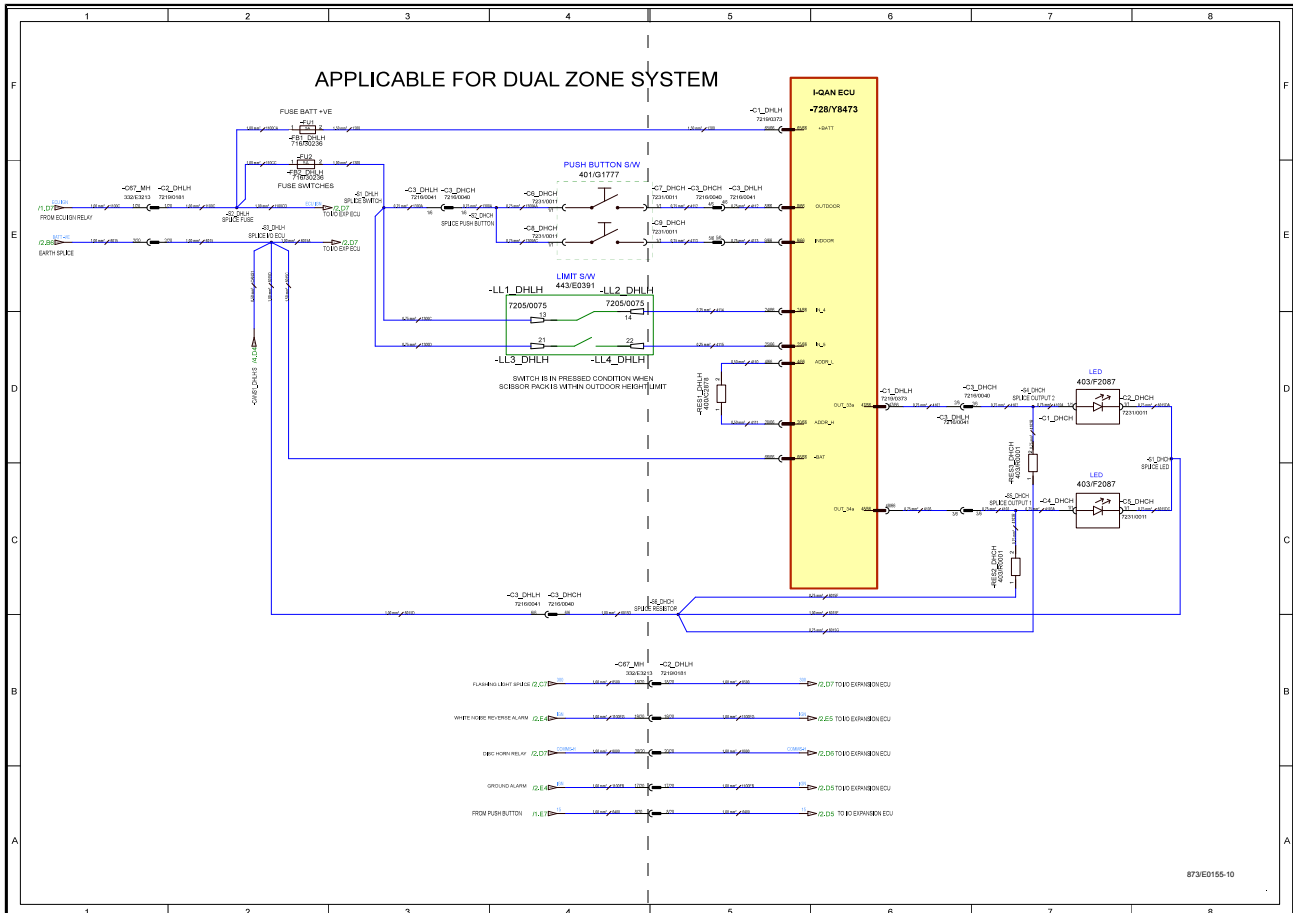
## 33 - Electrical System

00 - Electrical System

50 - Schematic Circuit

---

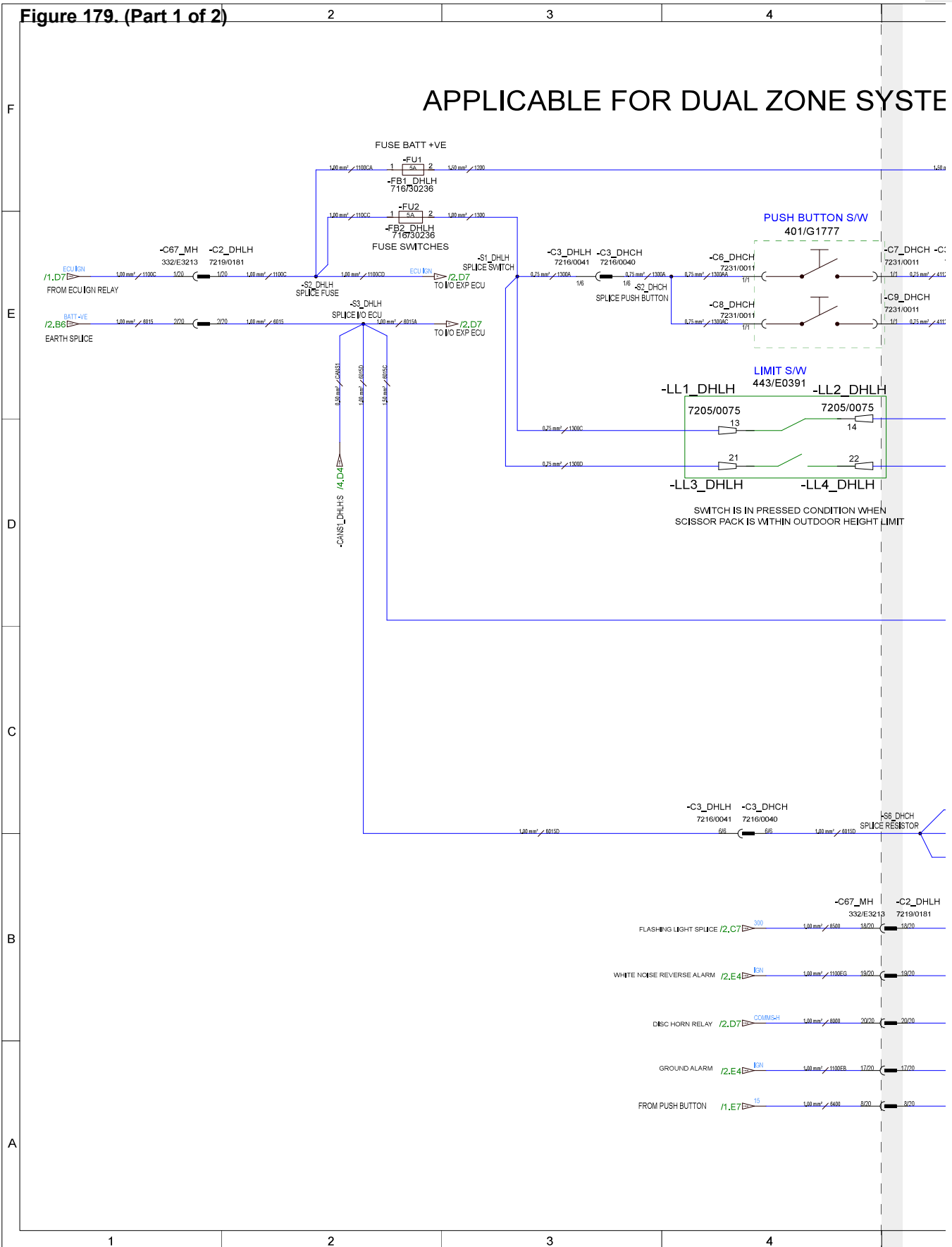
JCB © CONNOR STANMORE - 13/03/2026 07:57.



JCB © CONNOR STANMORE - 13/03/2026 07:57.

Figure 179. (Part 1 of 2)

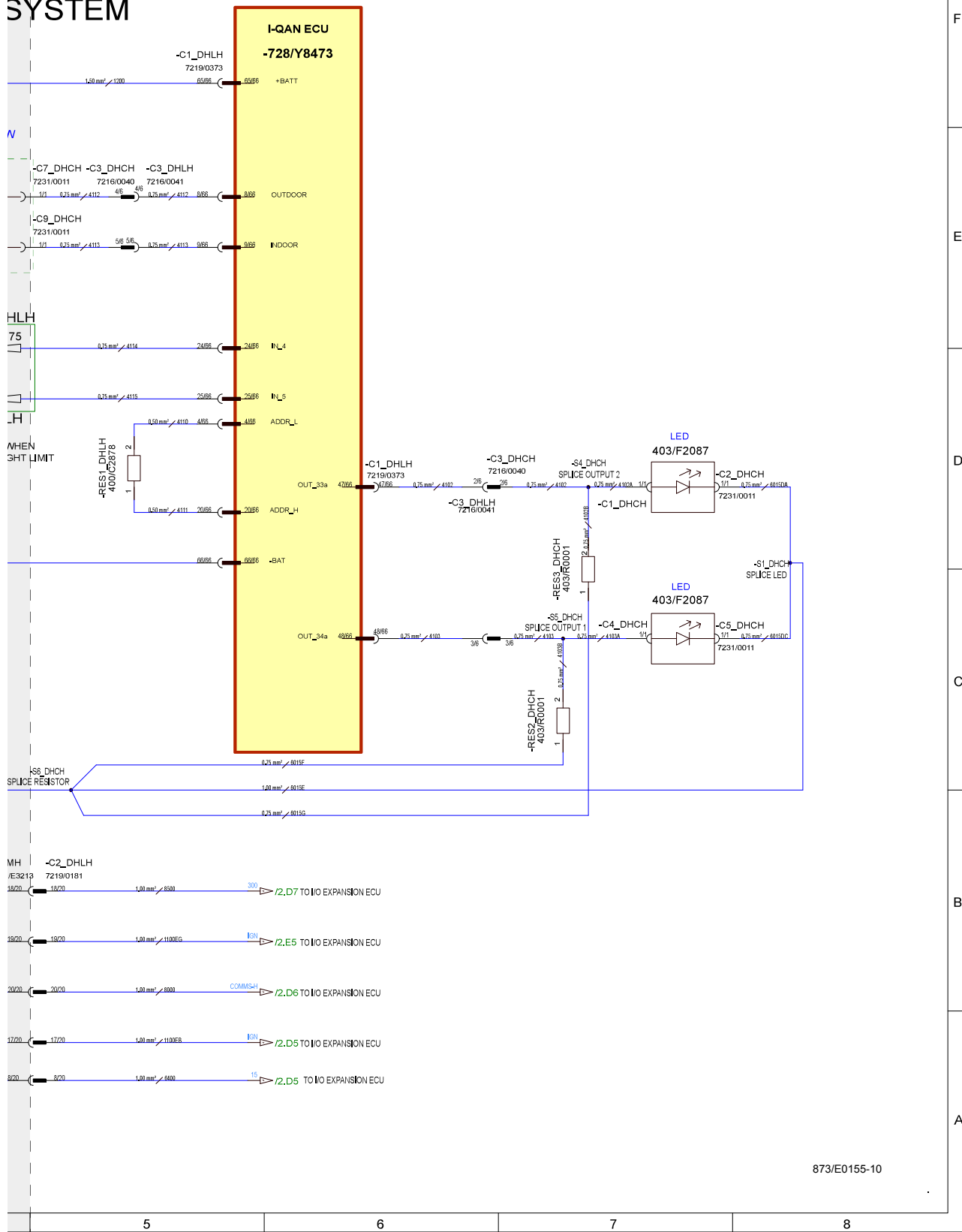
APPLICABLE FOR DUAL ZONE SYSTEM



Page 33-37

Figure 179. (Part 2 of 2)

## SYSTEM



873/E0155-10

JCB © CONNOR STANMORE - 13/03/2026 07:57.



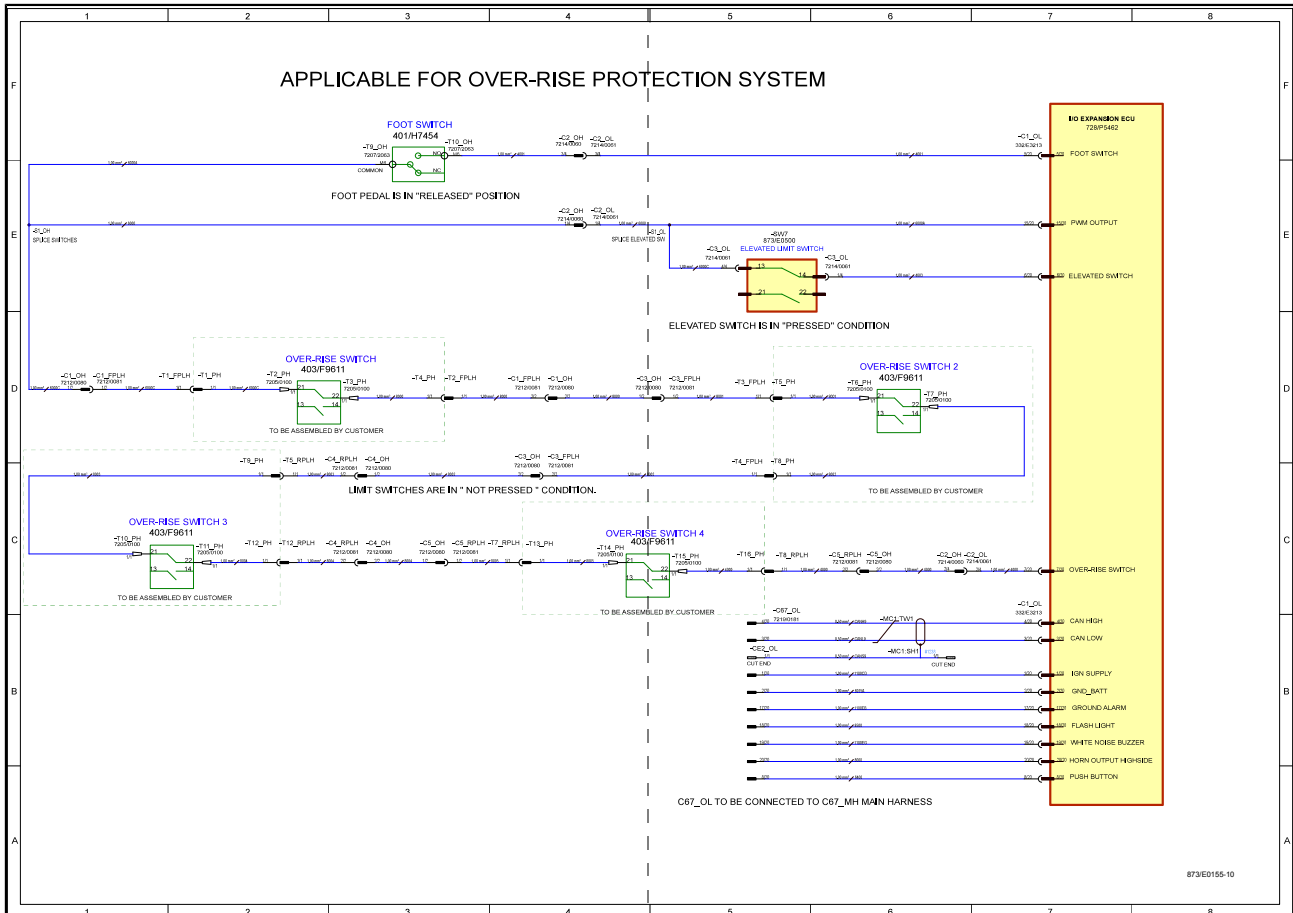
## 33 - Electrical System

00 - Electrical System

50 - Schematic Circuit

---

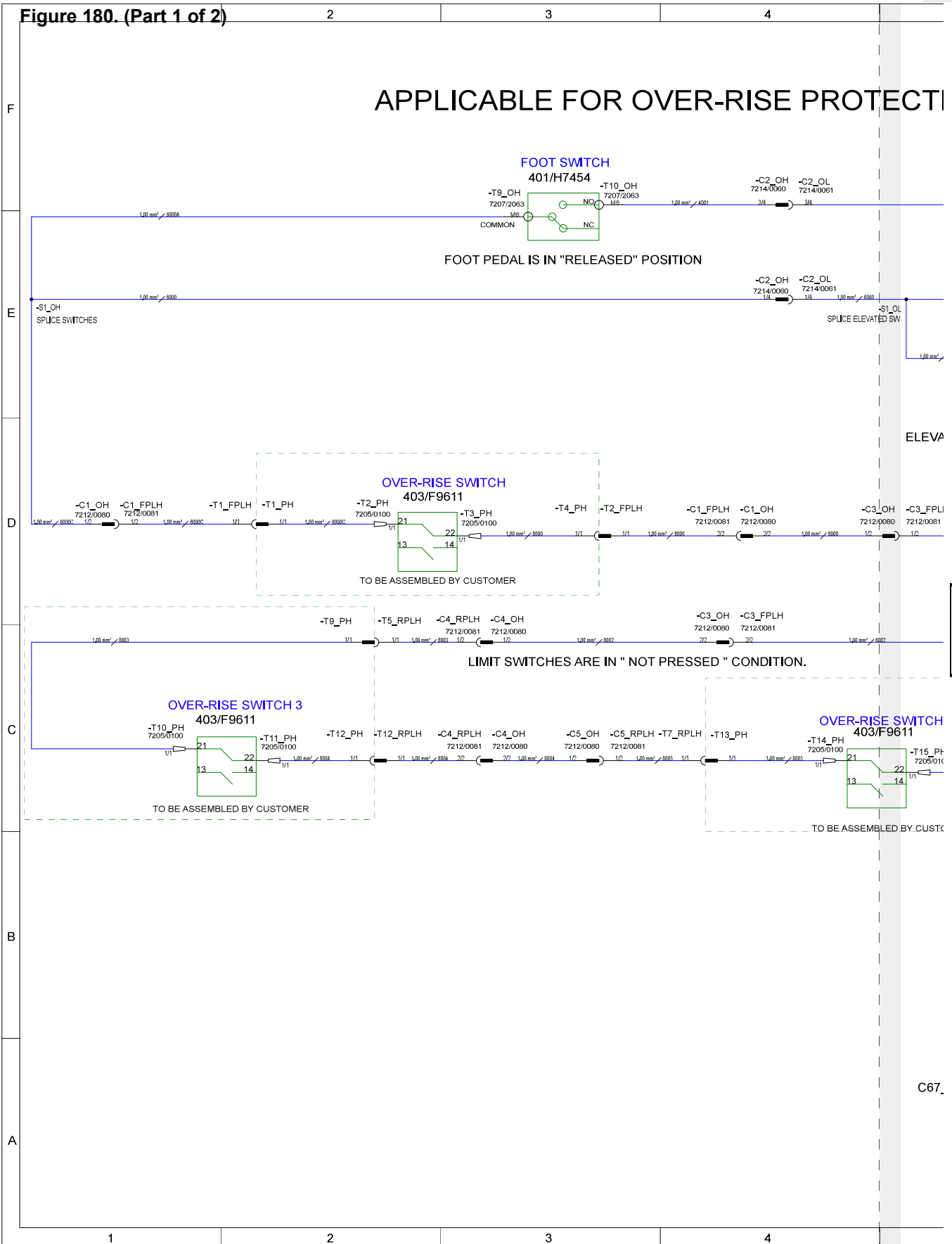
JCB © CONNOR STANMORE - 13/03/2026 07:57.



JCB © CONNOR STANMORE - 13/03/2026 07:57.

Figure 180. (Part 1 of 2)

APPLICABLE FOR OVER-RISE PROTECTI

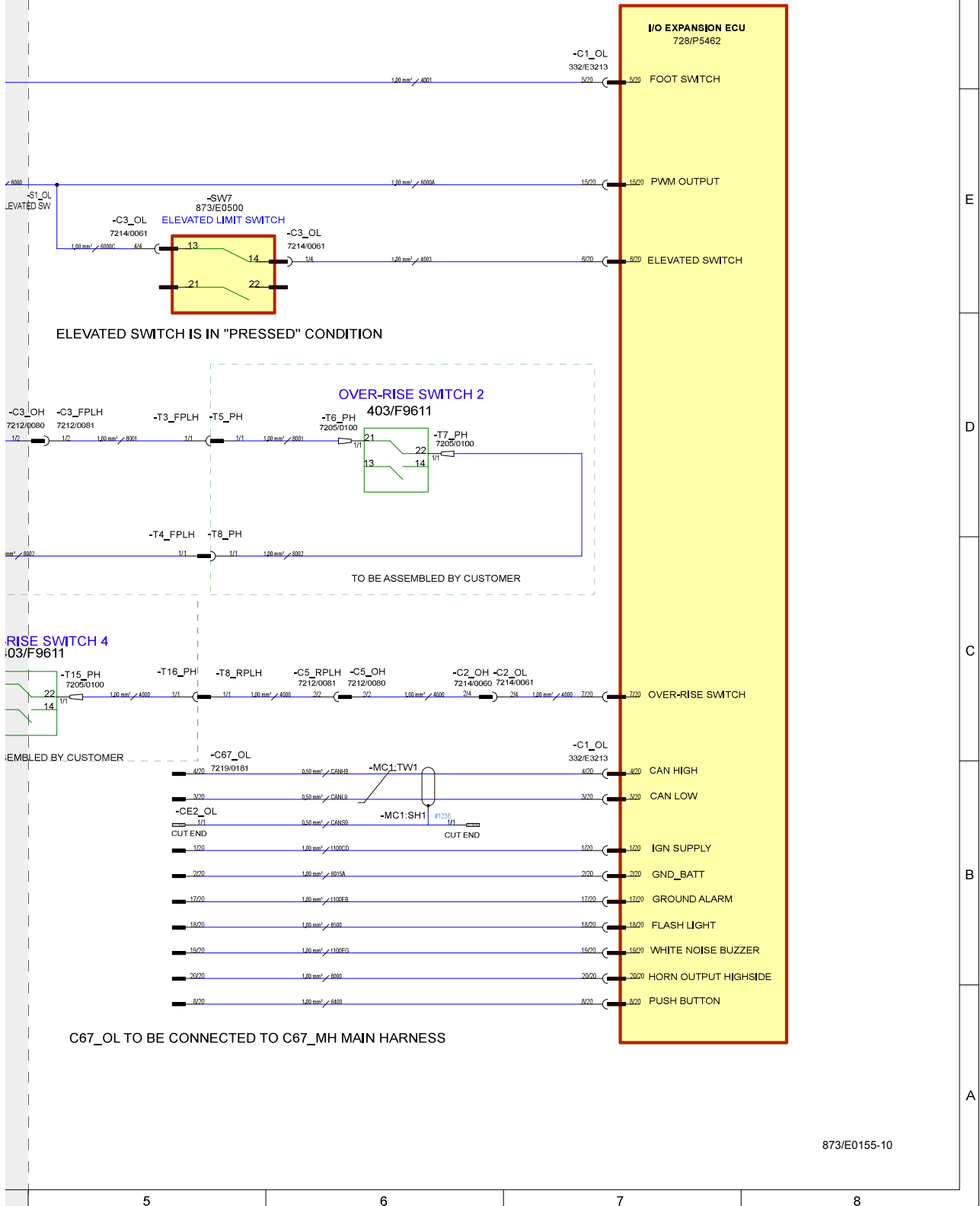


Page 33-41

JCB © CONNOR STANMORE - 13/03/2026 07:57.

Figure 180. (Part 2 of 2)

# PROTECTION SYSTEM



873/E0155-10

JCB © CONNOR STANMORE - 13/03/2026 07:57.



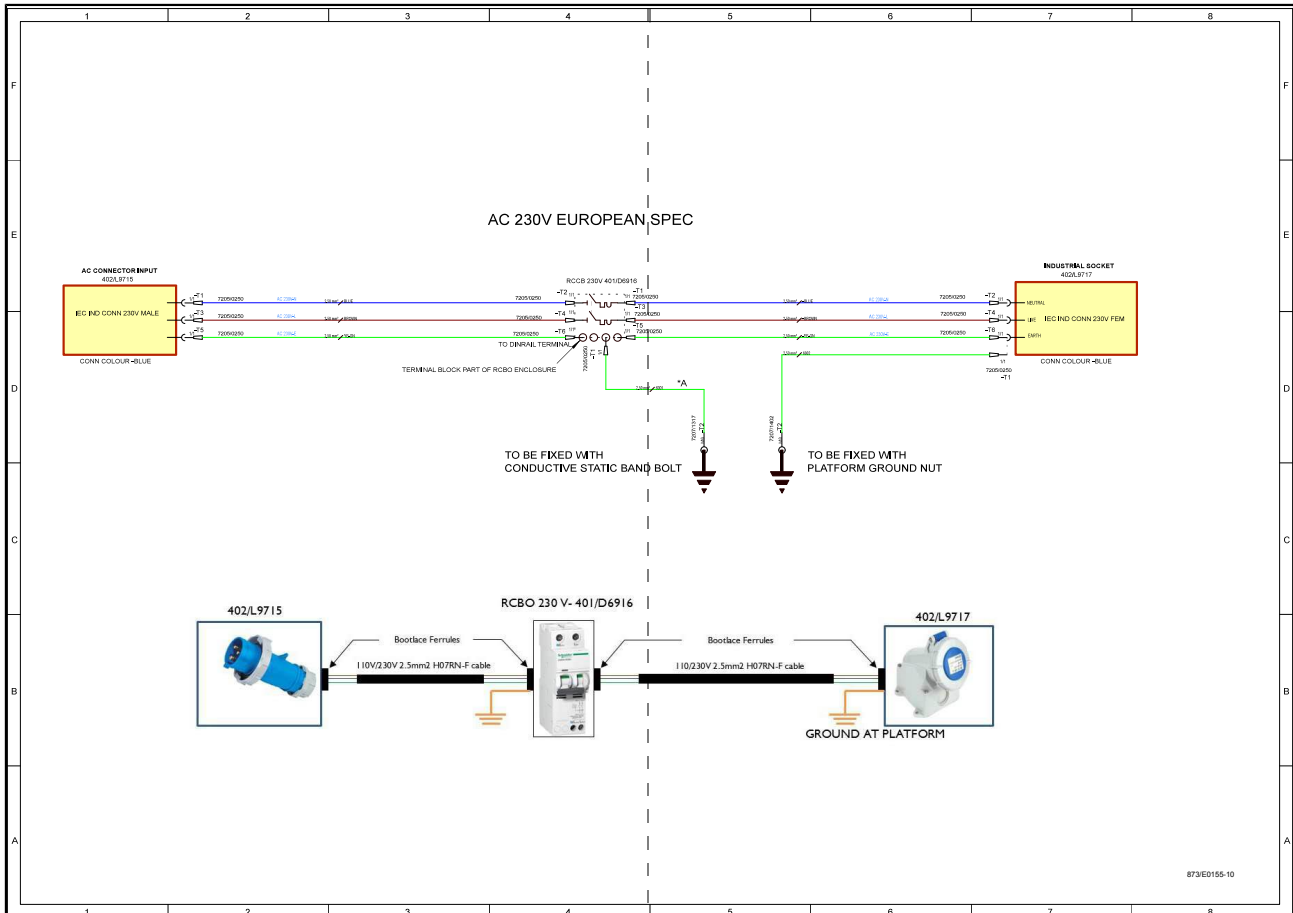
## 33 - Electrical System

00 - Electrical System

50 - Schematic Circuit

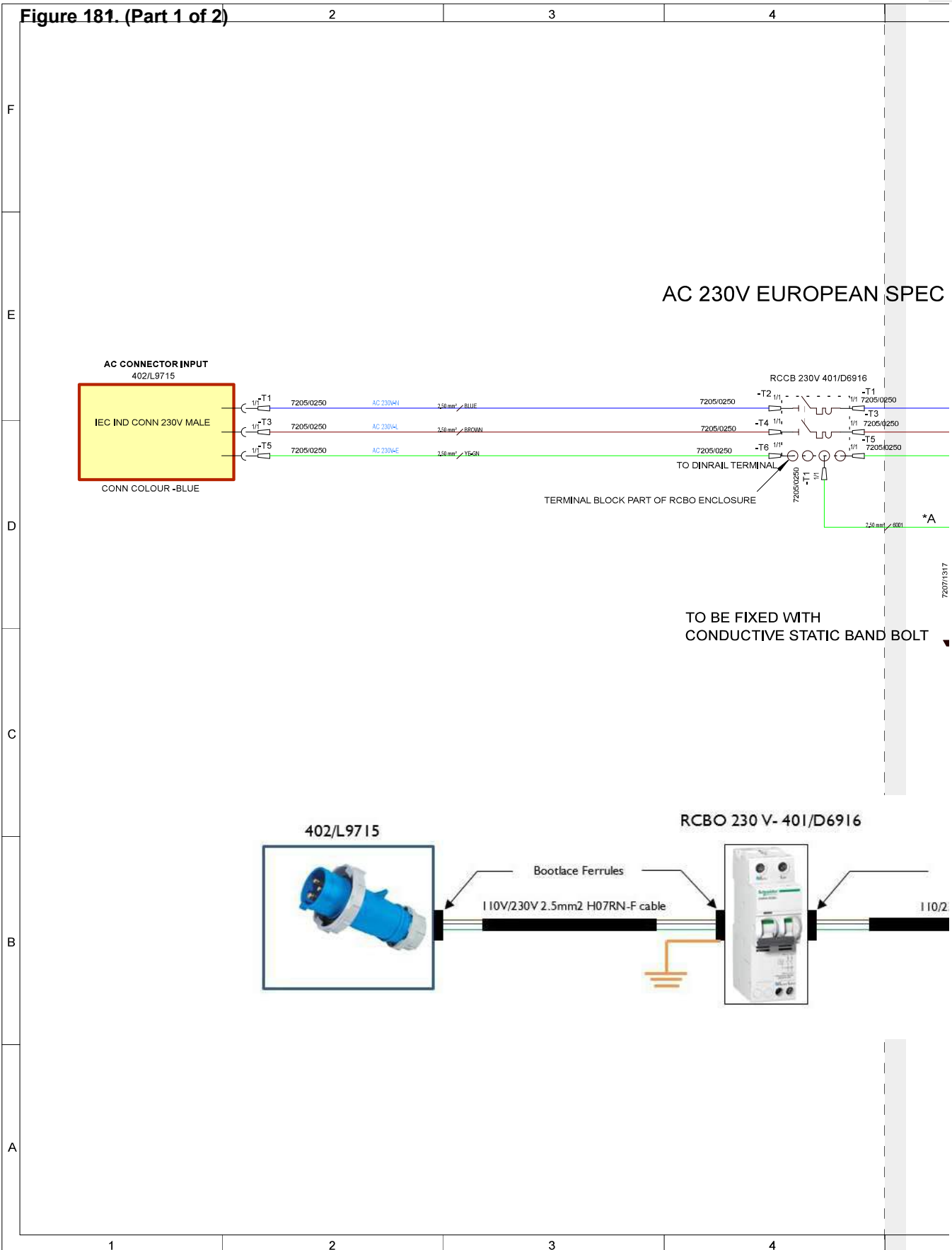
---

JCB © CONNOR STANMORE - 13/03/2026 07:57.



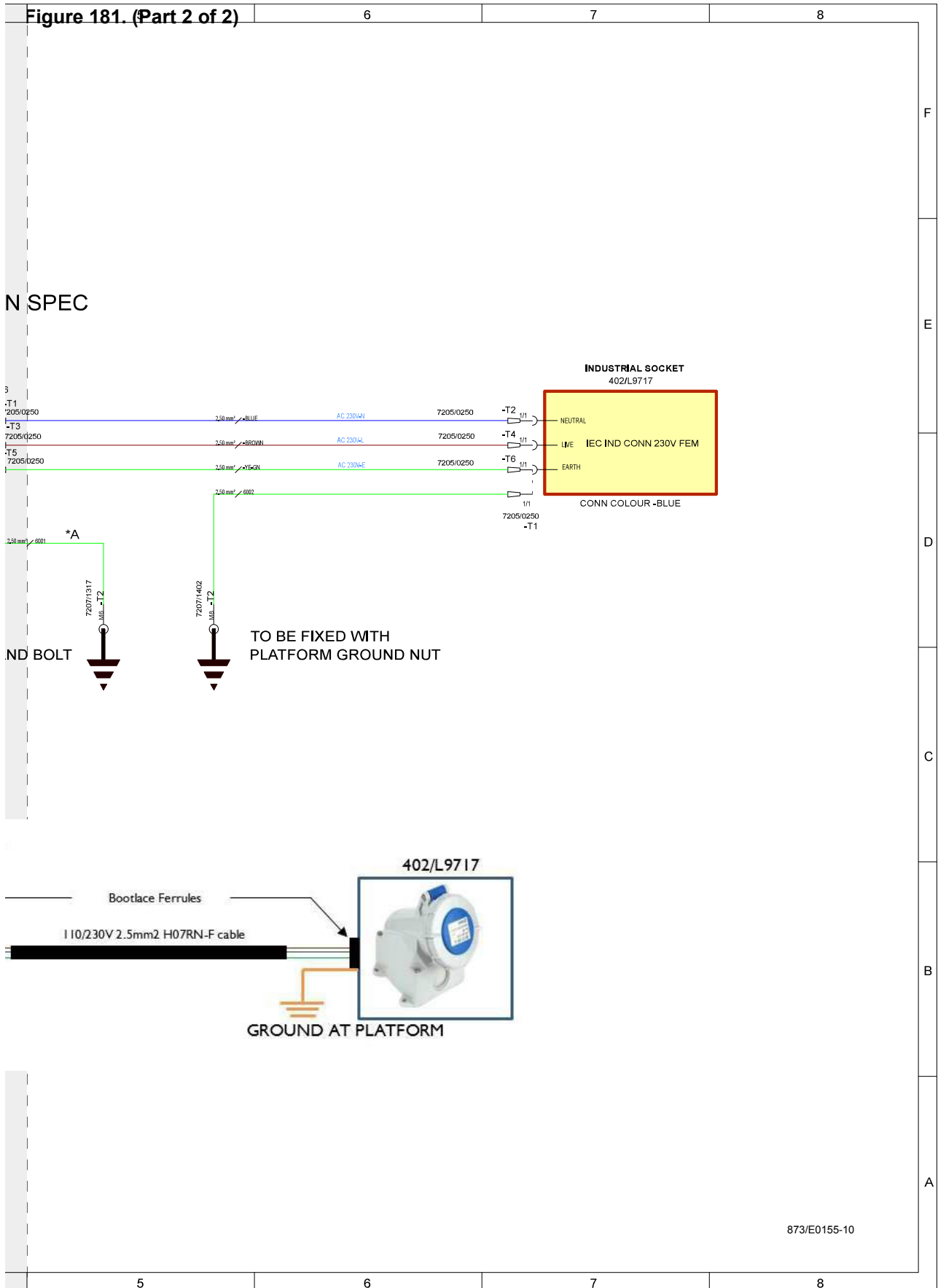
JCB © CONNOR STANMORE - 13/03/2026 07:57.

**Figure 181. (Part 1 of 2)**



JCB © CONNOR STANMORE - 13/03/2026 07:57.

Figure 181. (Part 2 of 2)



JCB © CONNOR STANMORE - 13/03/2026 07:57.



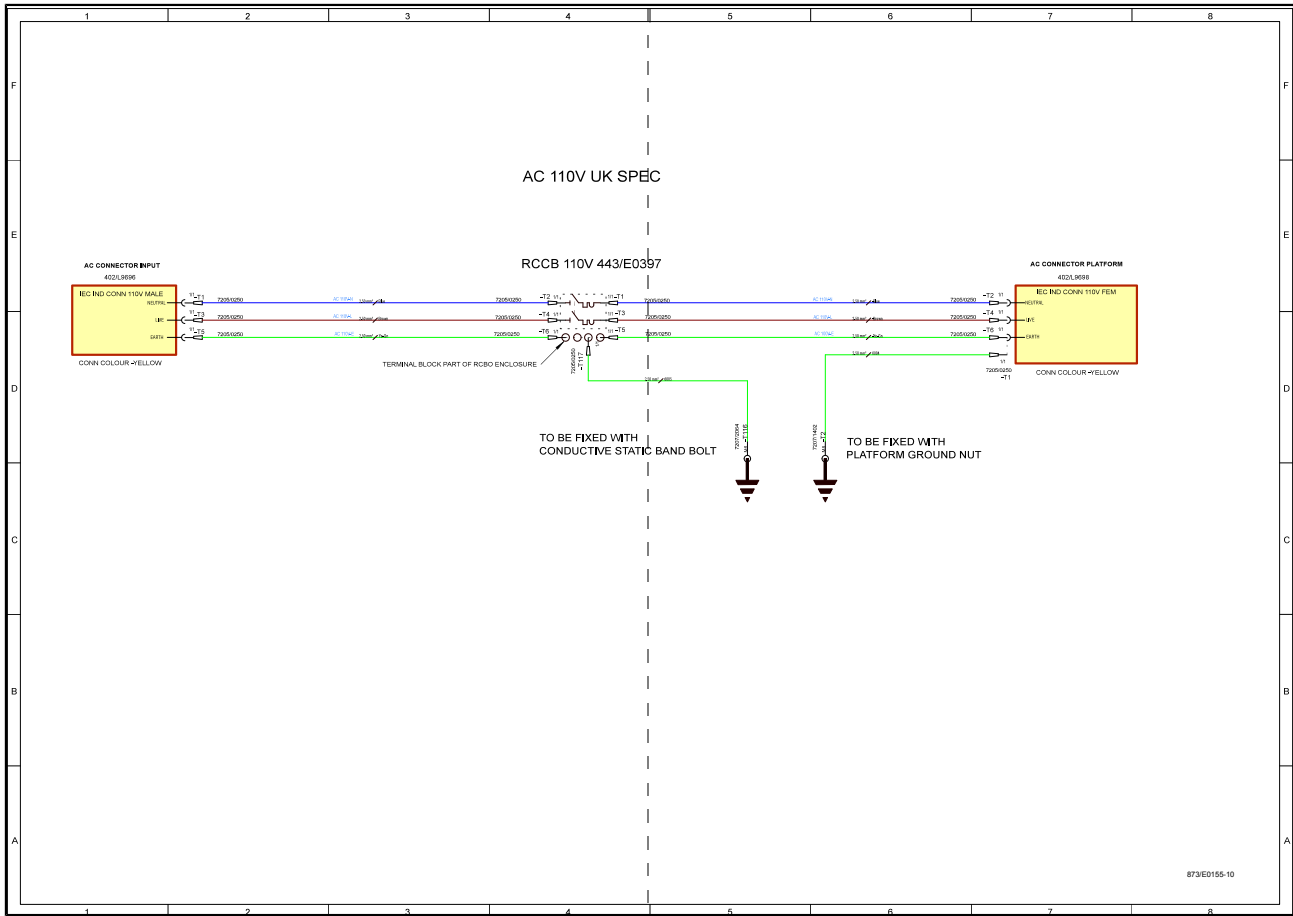
## 33 - Electrical System

00 - Electrical System

50 - Schematic Circuit

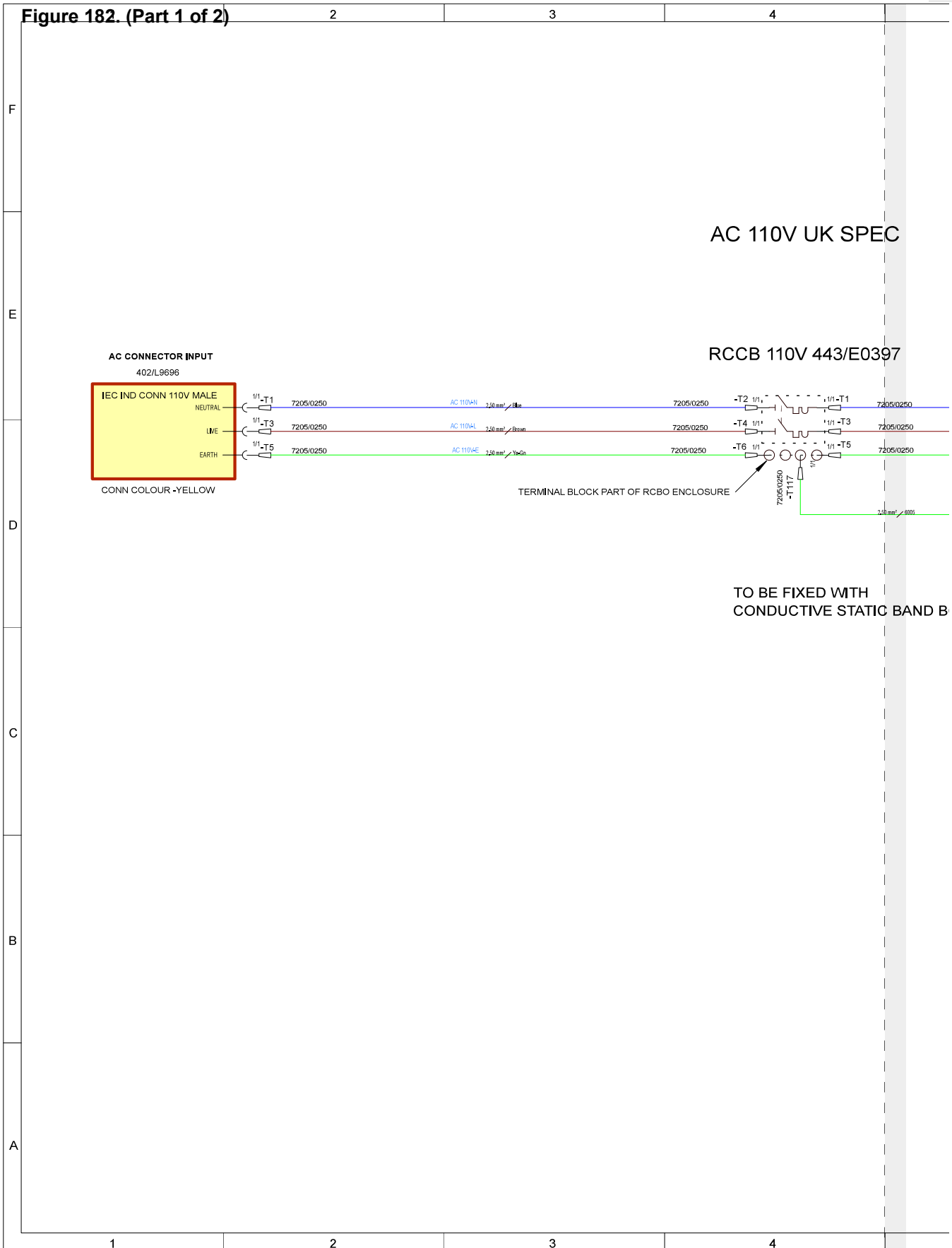
---

JCB © CONNOR STANMORE - 13/03/2026 07:57.



JCB © CONNOR STANMORE - 13/03/2026 07:57.

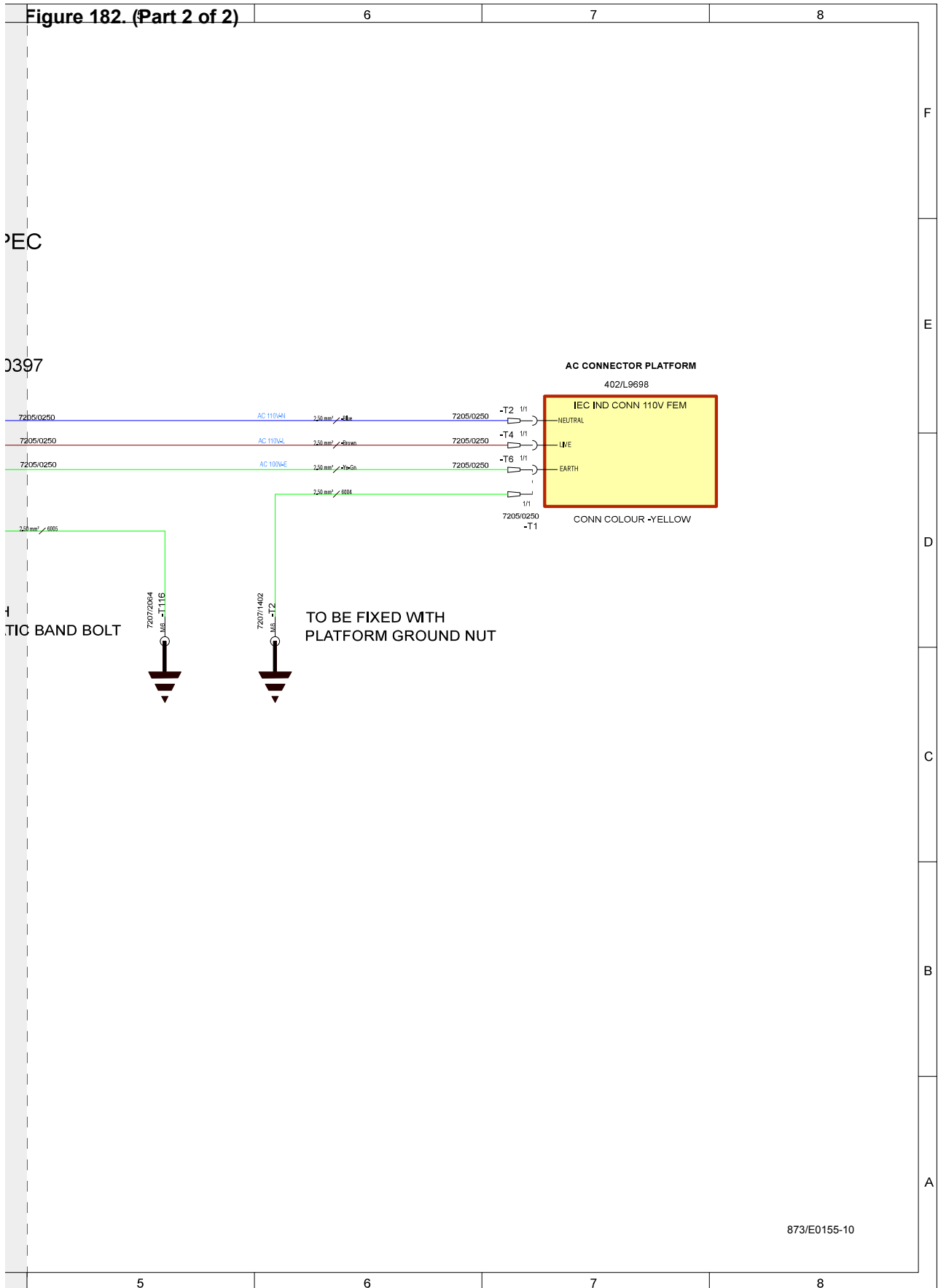
Figure 182. (Part 1 of 2)



Page 33-49

JCB © CONNOR STANMORE - 13/03/2026 07:57.

Figure 182. (Part 2 of 2)



JCB © CONNOR STANMORE - 13/03/2026 07:57.

Page 33-48



## 33 - Electrical System

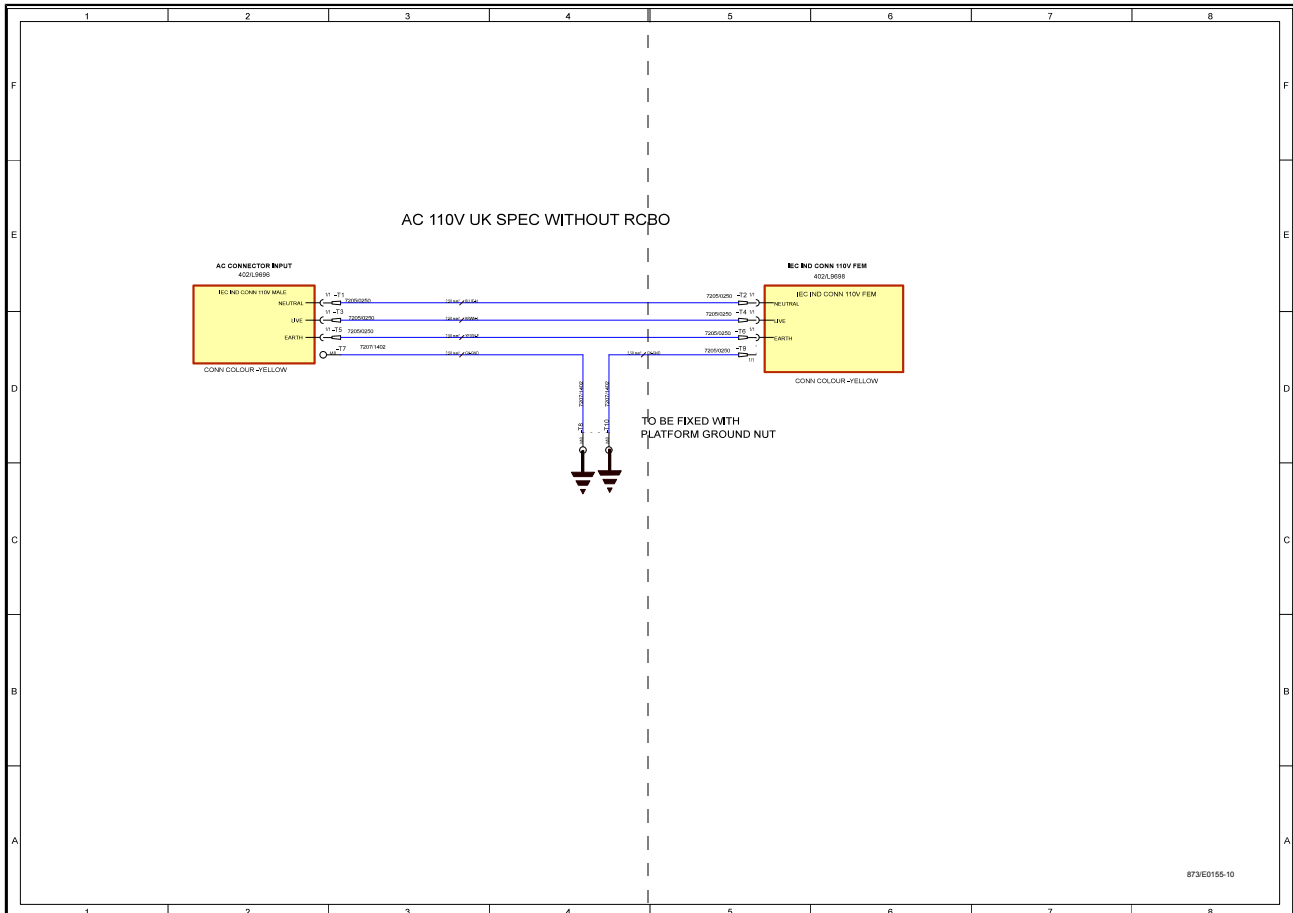
00 - Electrical System

50 - Schematic Circuit

---

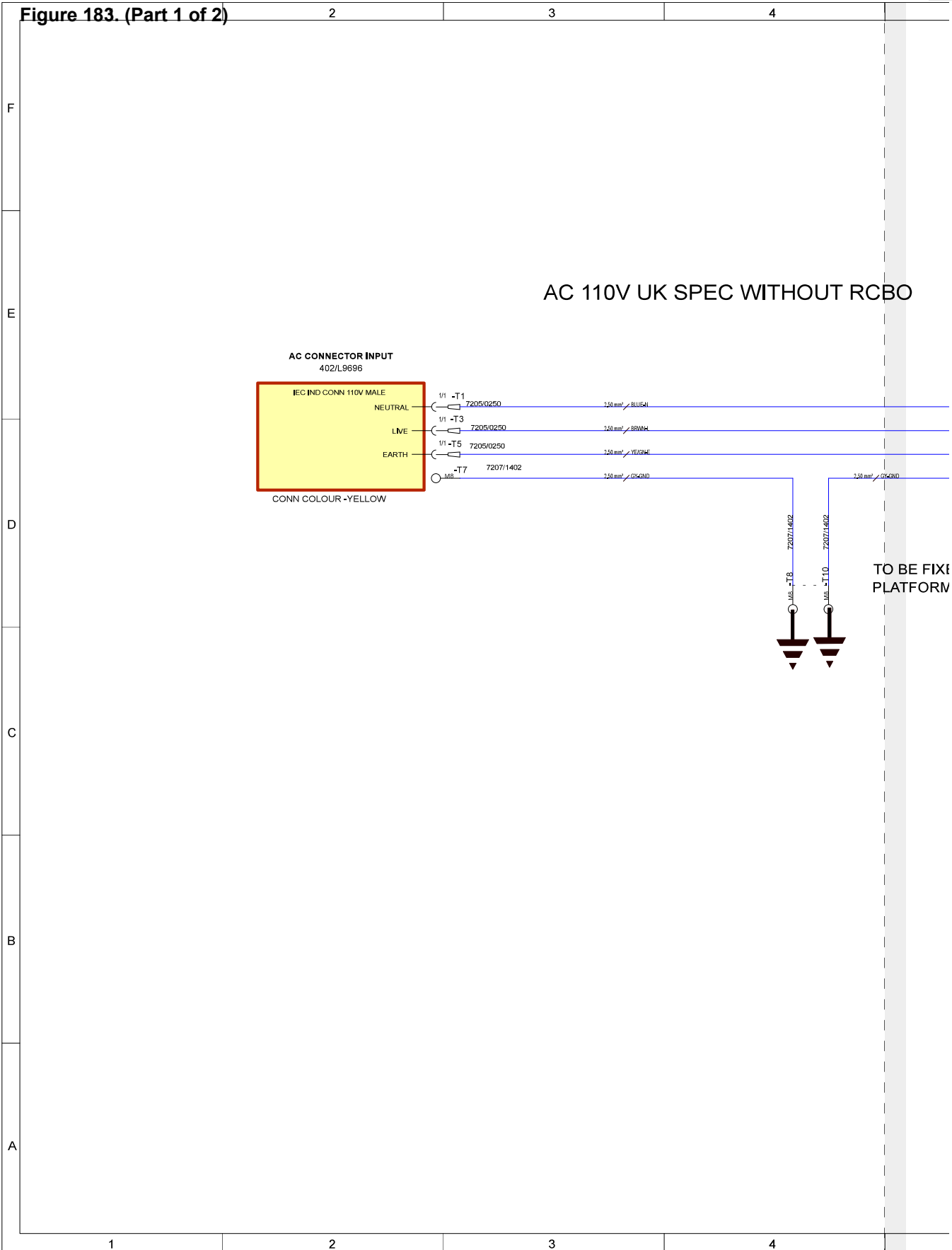
JCB © CONNOR STANMORE - 13/03/2026 07:57.

Figure 183. 873/E0155 Issue 10 (Sheet 9 of 14) - Power to Platform UK W/O RCCBO



JCB © CONNOR STANMORE - 13/03/2026 07:57.

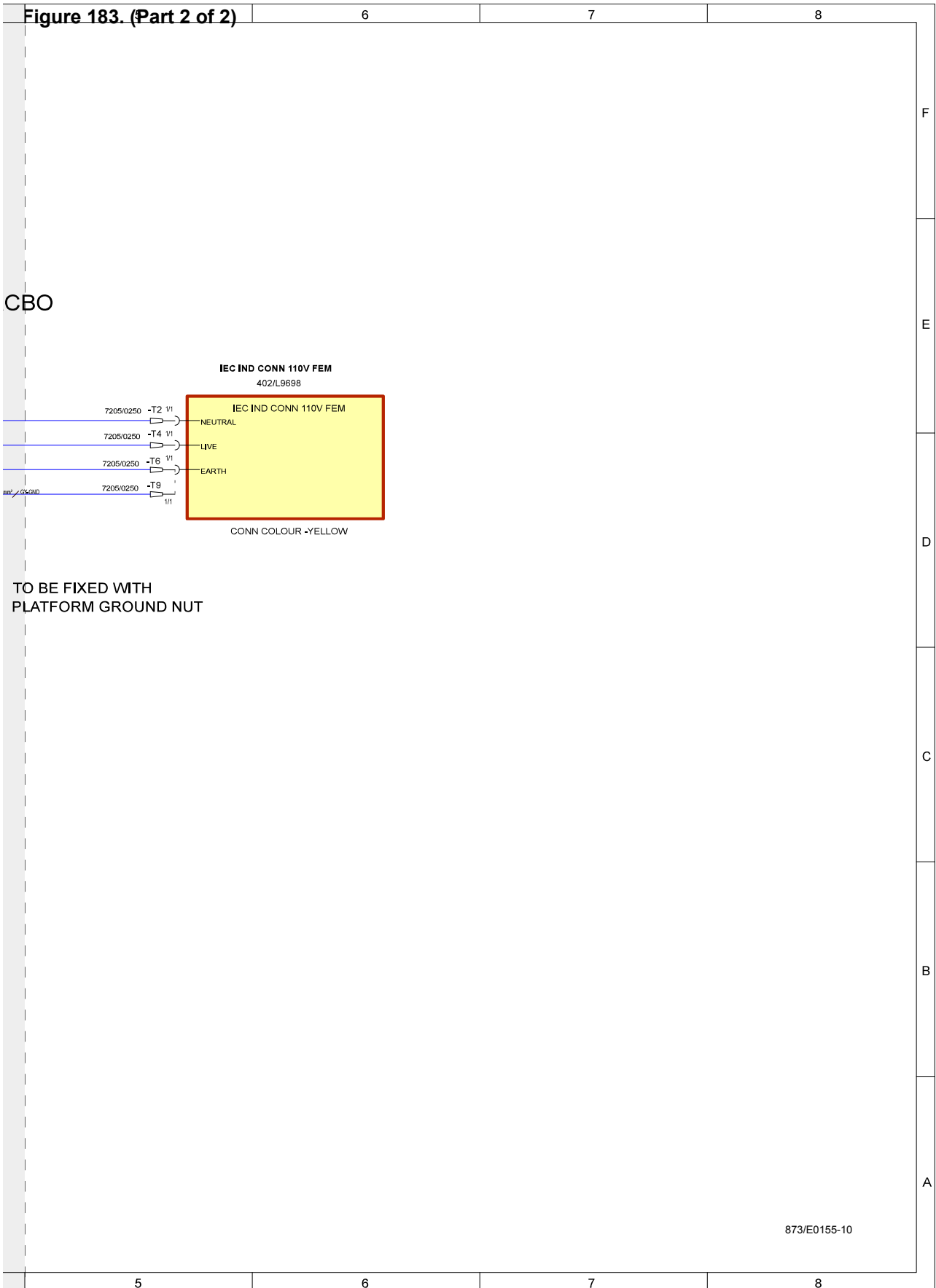
Figure 183. (Part 1 of 2)



Page 33-53

JCB © CONNOR STANMORE - 13/03/2026 07:57.

Figure 183. (Part 2 of 2)



JCB © CONNOR STANMORE - 13/03/2026 07:57.

Page 33-52



## 33 - Electrical System

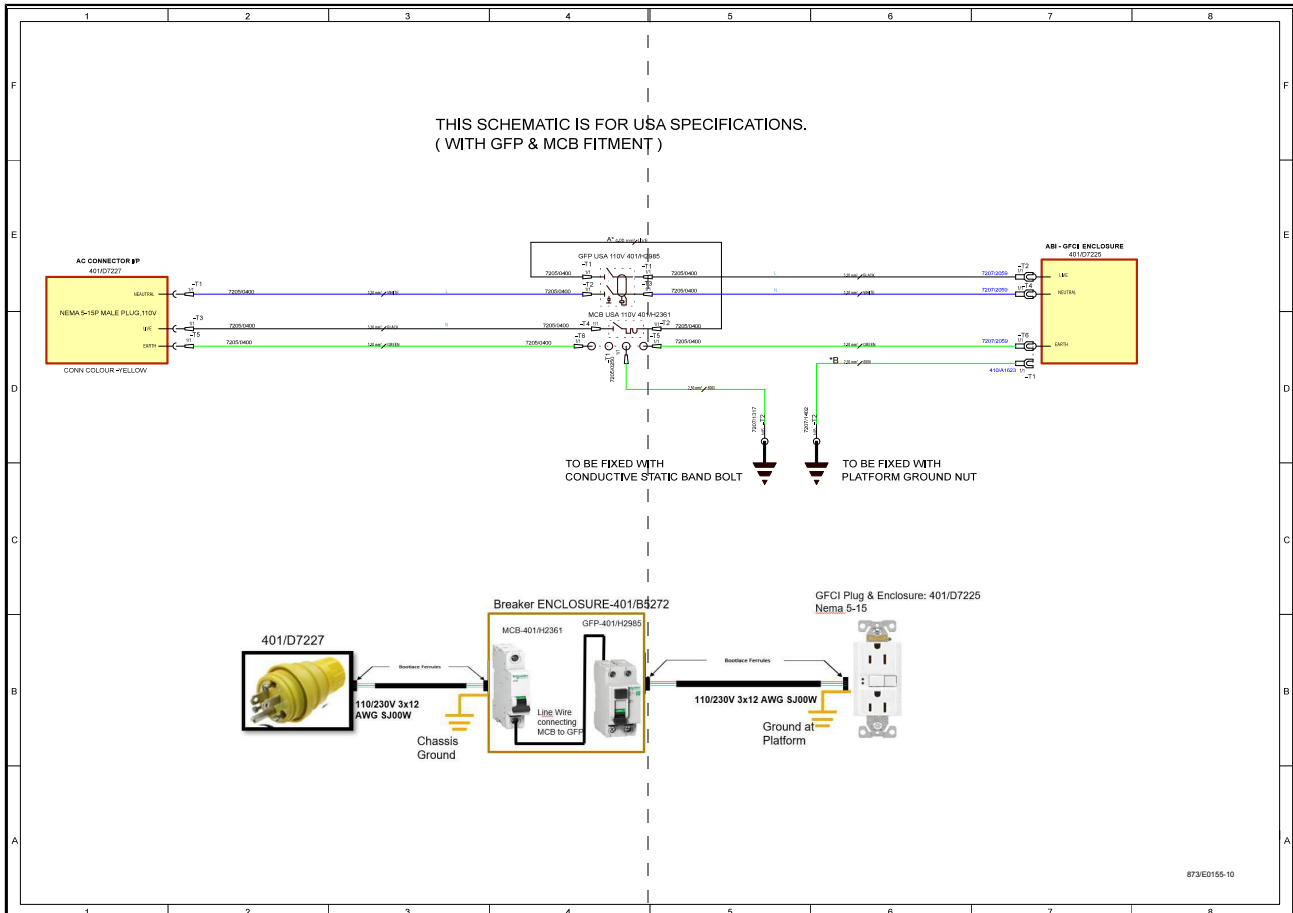
00 - Electrical System

50 - Schematic Circuit

---

JCB © CONNOR STANMORE - 13/03/2026 07:57.

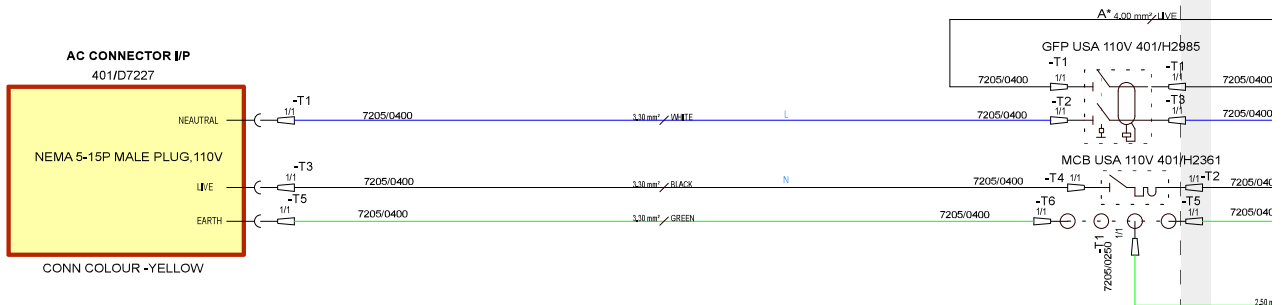
Figure 184. 873/E0155 Issue 10 (Sheet 10 of 14) - Power to Platform US



JCB © CONNOR STANMORE - 13/03/2026 07:57.

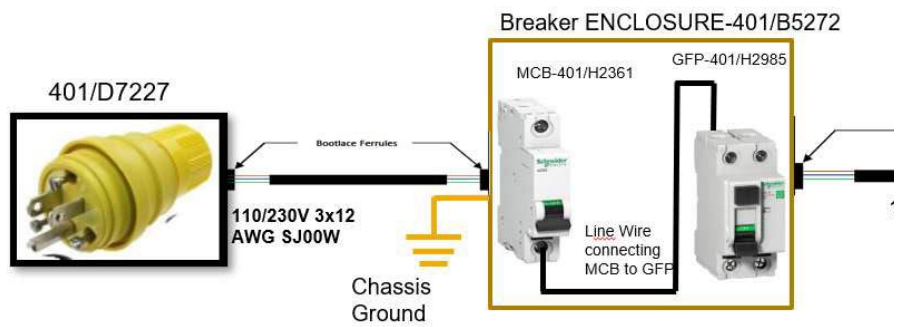
Figure 184. (Part 1 of 2)

THIS SCHEMATIC IS FOR USA SPE  
( WITH GFP & MCB FITMENT )



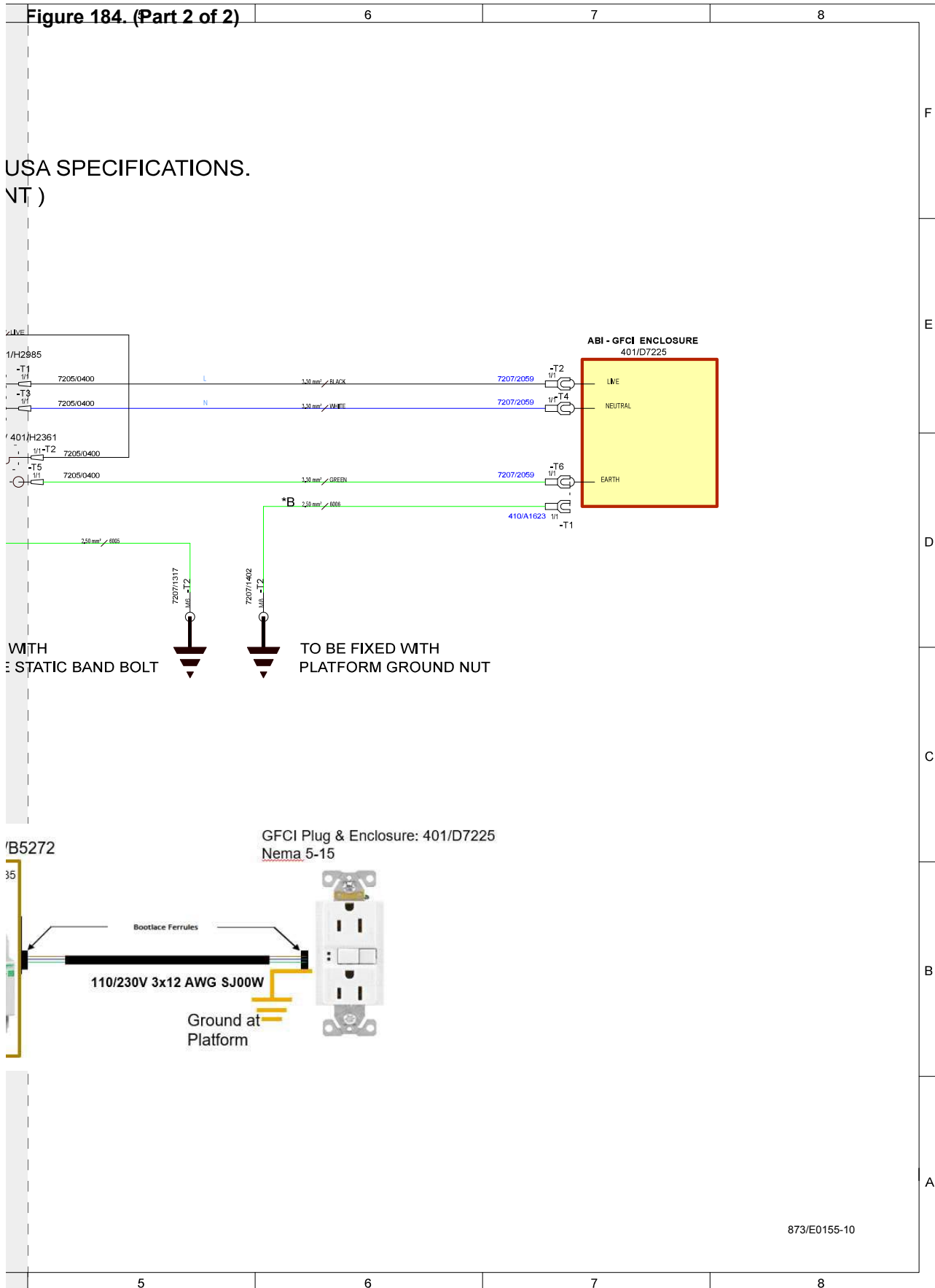
TO BE FIXED WITH CONDUCTIVE STATIC BA

Page 33-57



JCB © CONNOR STANMORE - 13/03/2026 07:57.

Figure 184. (Part 2 of 2)



JCB © CONNOR STANMORE - 13/03/2026 07:57.



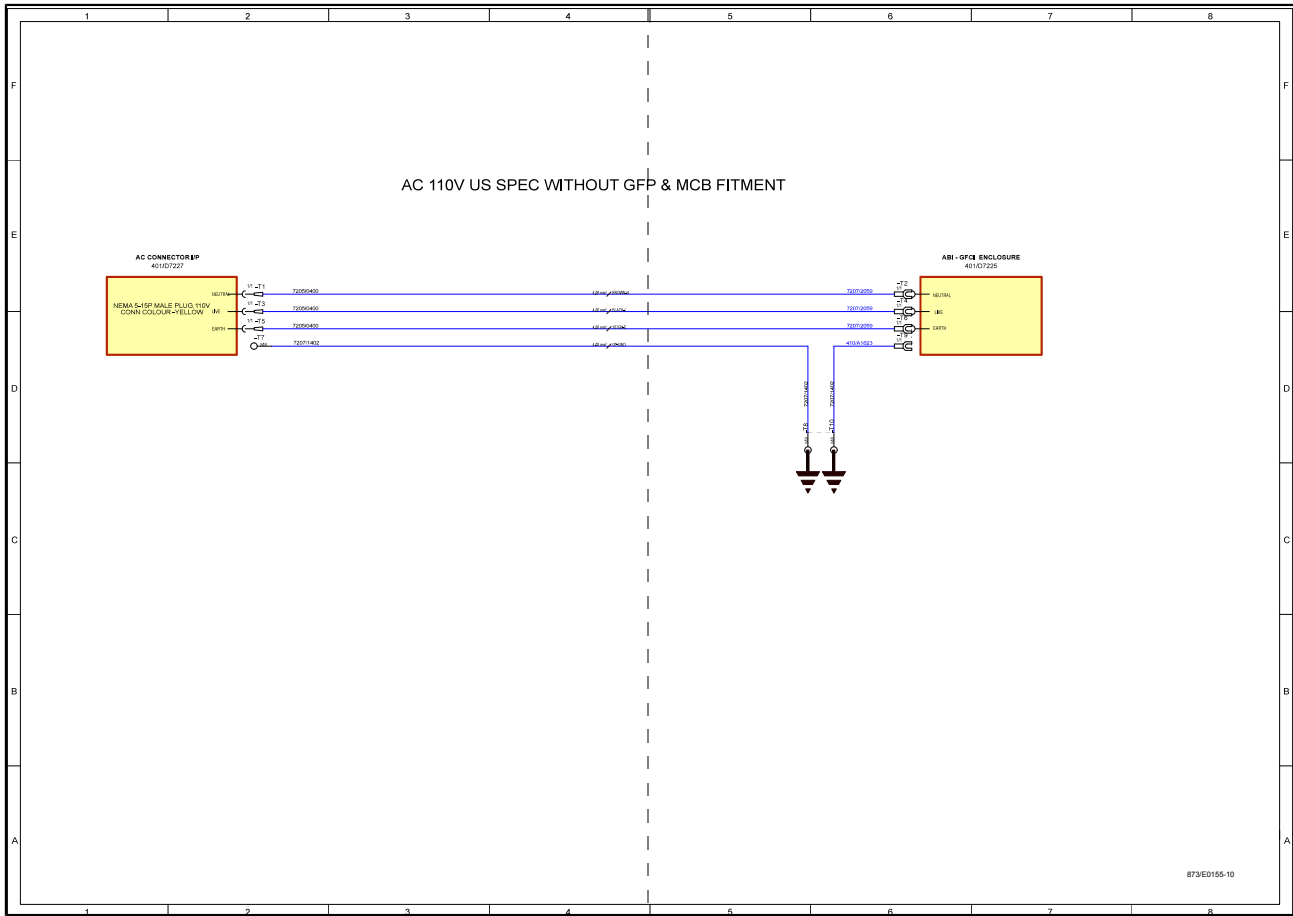
## 33 - Electrical System

00 - Electrical System

50 - Schematic Circuit

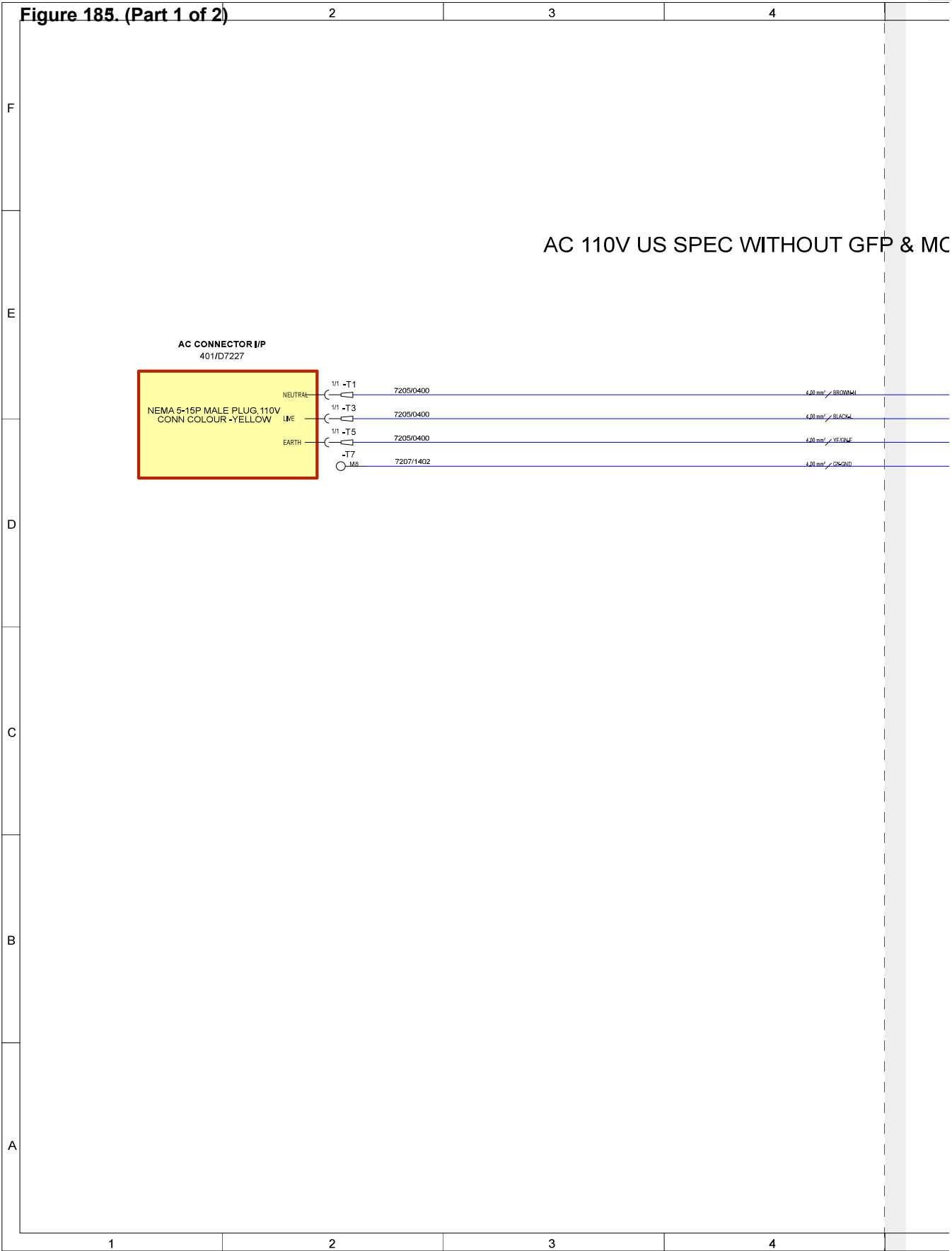
---

JCB © CONNOR STANMORE - 13/03/2026 07:57.



JCB © CONNOR STANMORE - 13/03/2026 07:57.

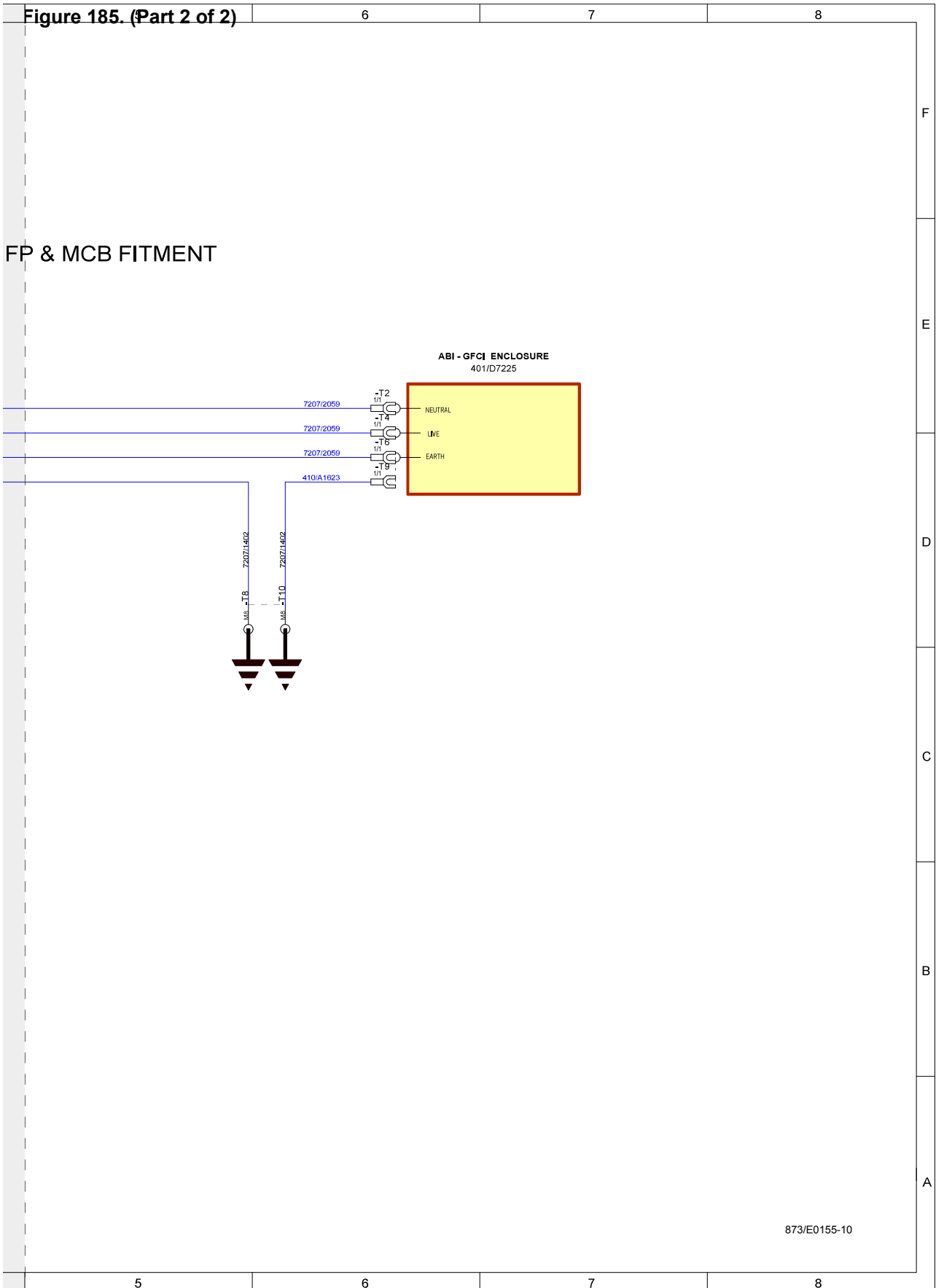
**Figure 185. (Part 1 of 2)**



Page 33-61

JCB © CONNOR STANMORE - 13/03/2026 07:57.

Figure 185. (Part 2 of 2)



Page 33-60

JCB © CONNOR STANMORE - 13/03/2026 07:57.



## 33 - Electrical System

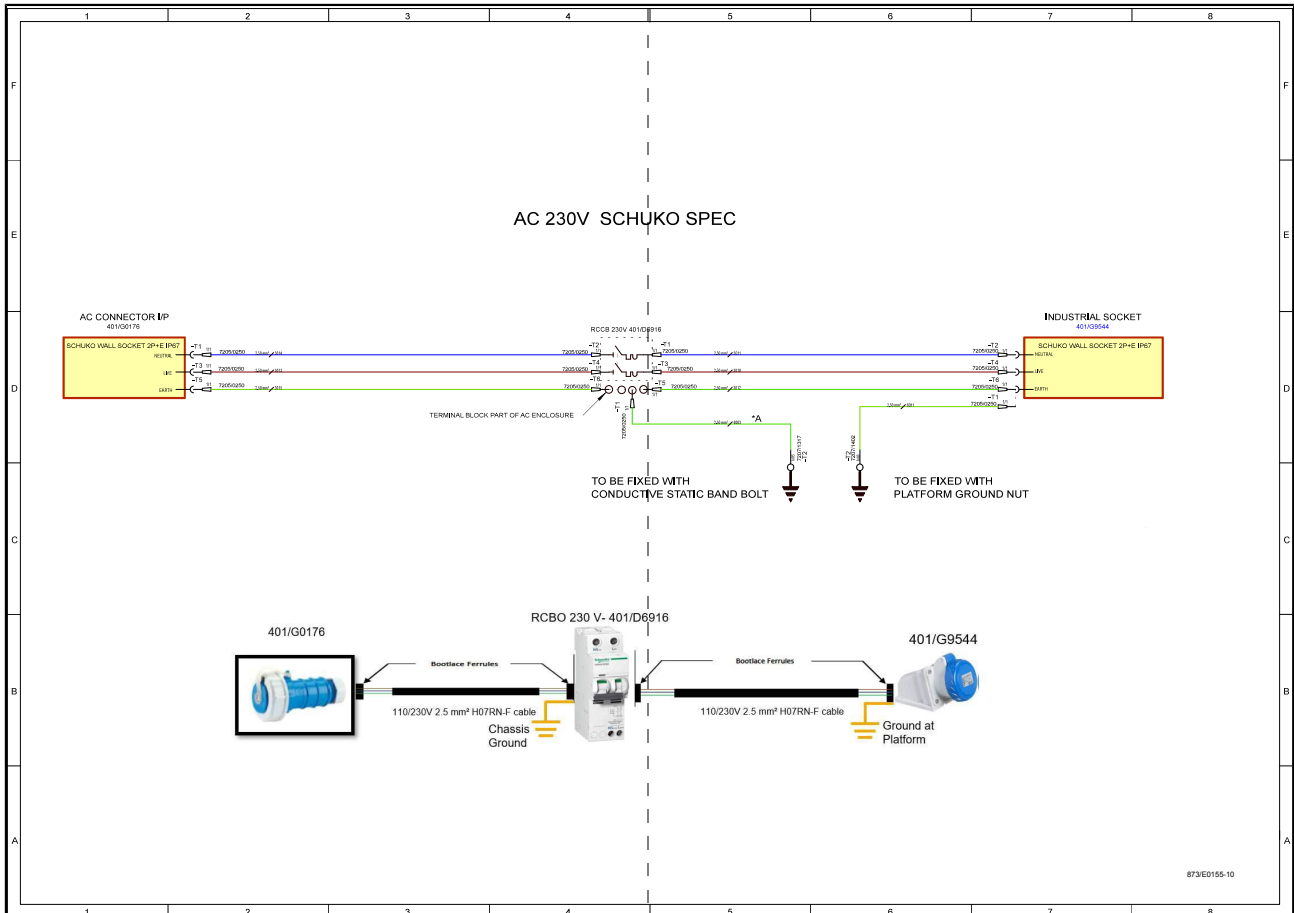
00 - Electrical System

50 - Schematic Circuit

---

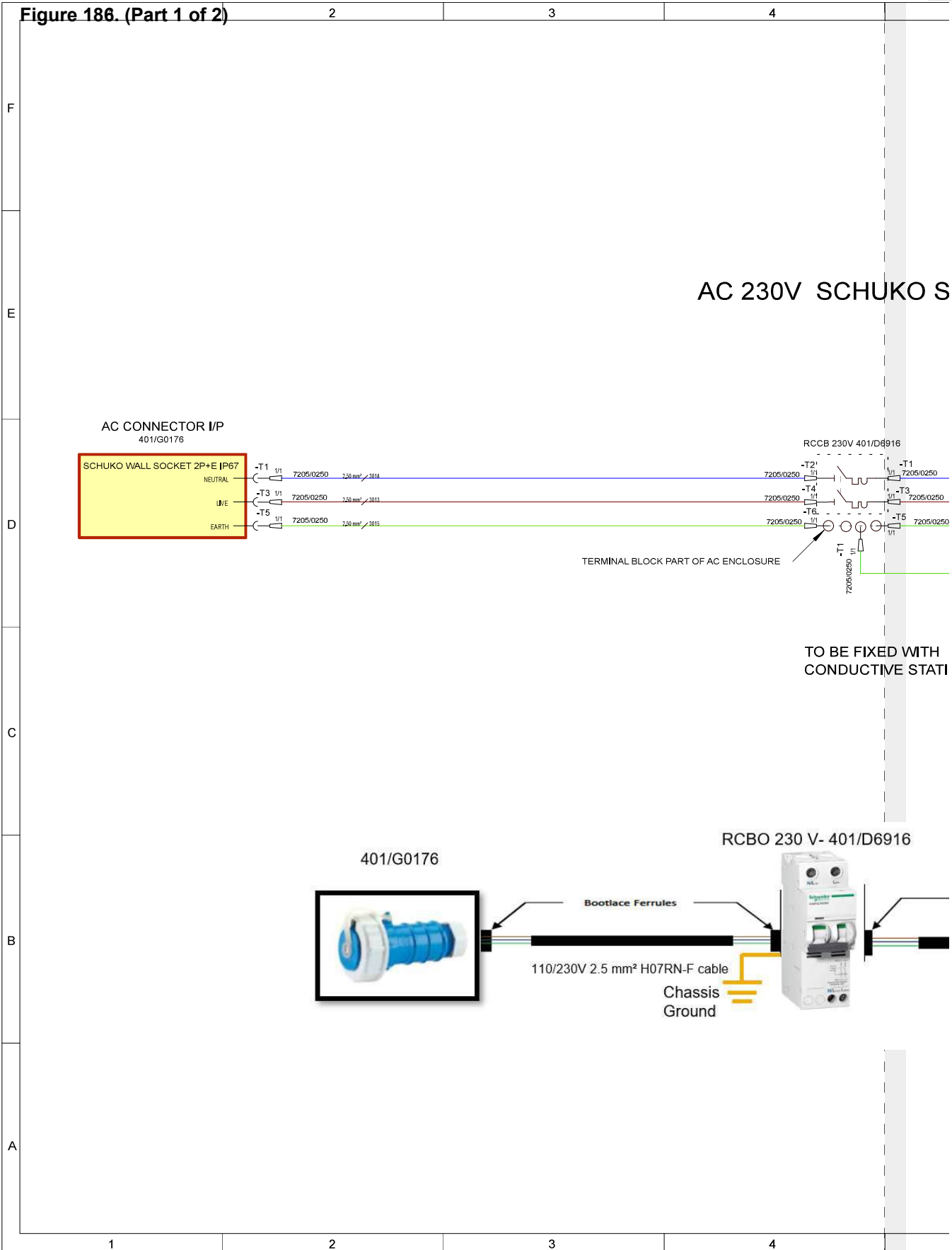
JCB © CONNOR STANMORE - 13/03/2026 07:57.

Figure 186. 873/E0155 Issue 10 (Sheet 12 of 14) - Power to Platform SCHUKO



JCB © CONNOR STANMORE - 13/03/2026 07:57.

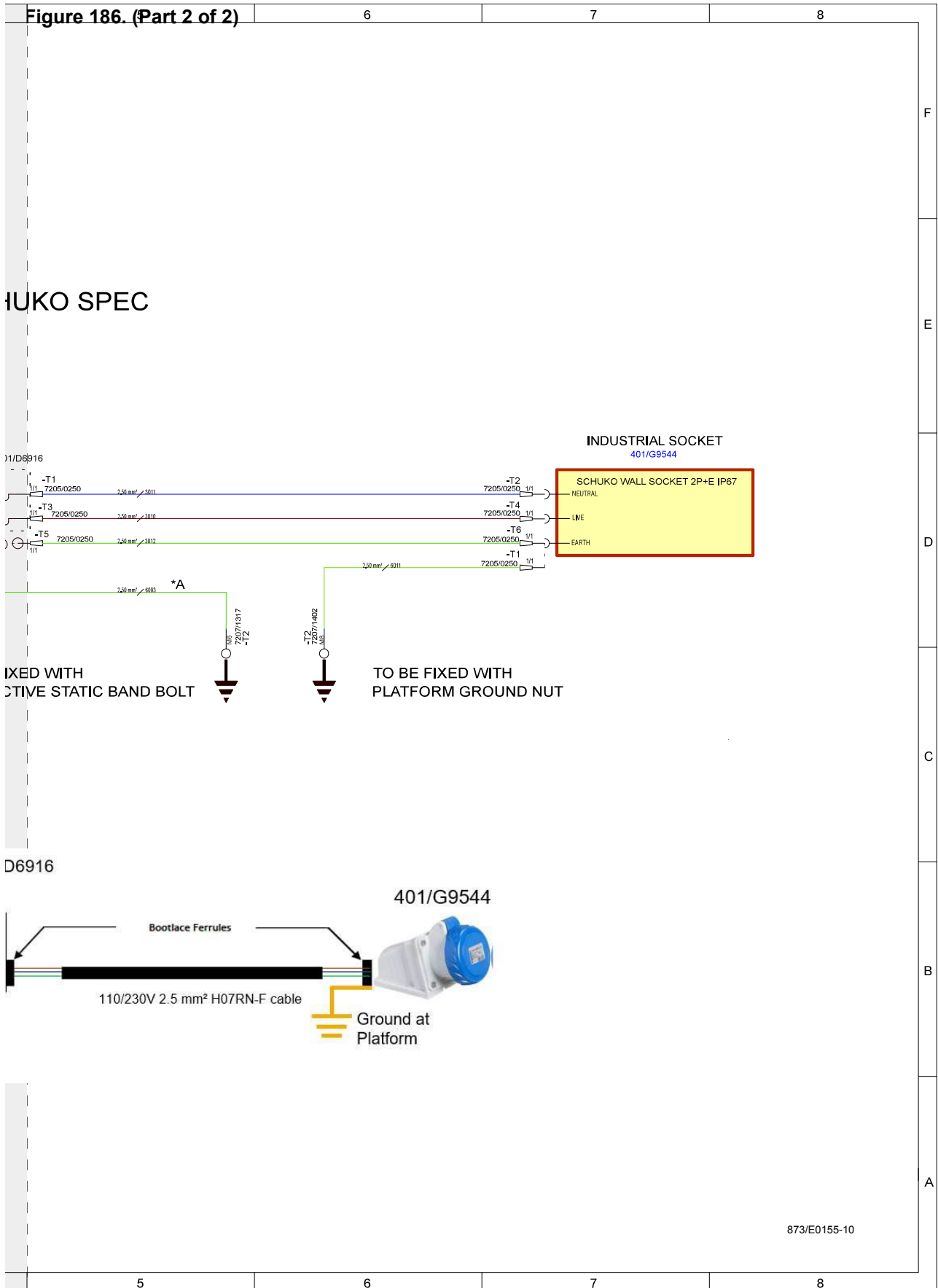
Figure 186. (Part 1 of 2)



Page 33-65

JCB © CONNOR STANMORE - 13/03/2026 07:57.

Figure 186. (Part 2 of 2)



JCB © CONNOR STANMORE - 13/03/2026 07:57.



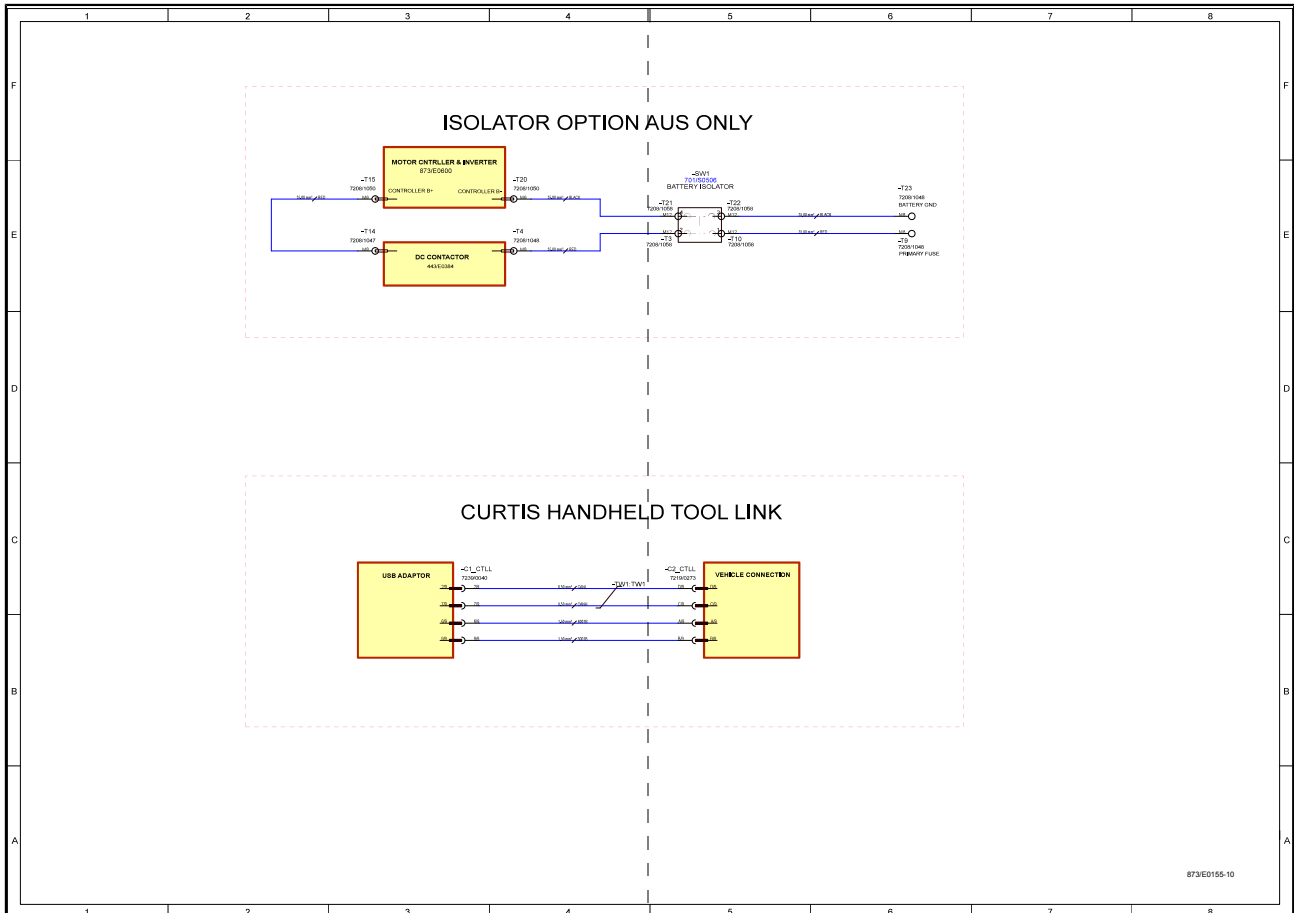
## 33 - Electrical System

00 - Electrical System

50 - Schematic Circuit

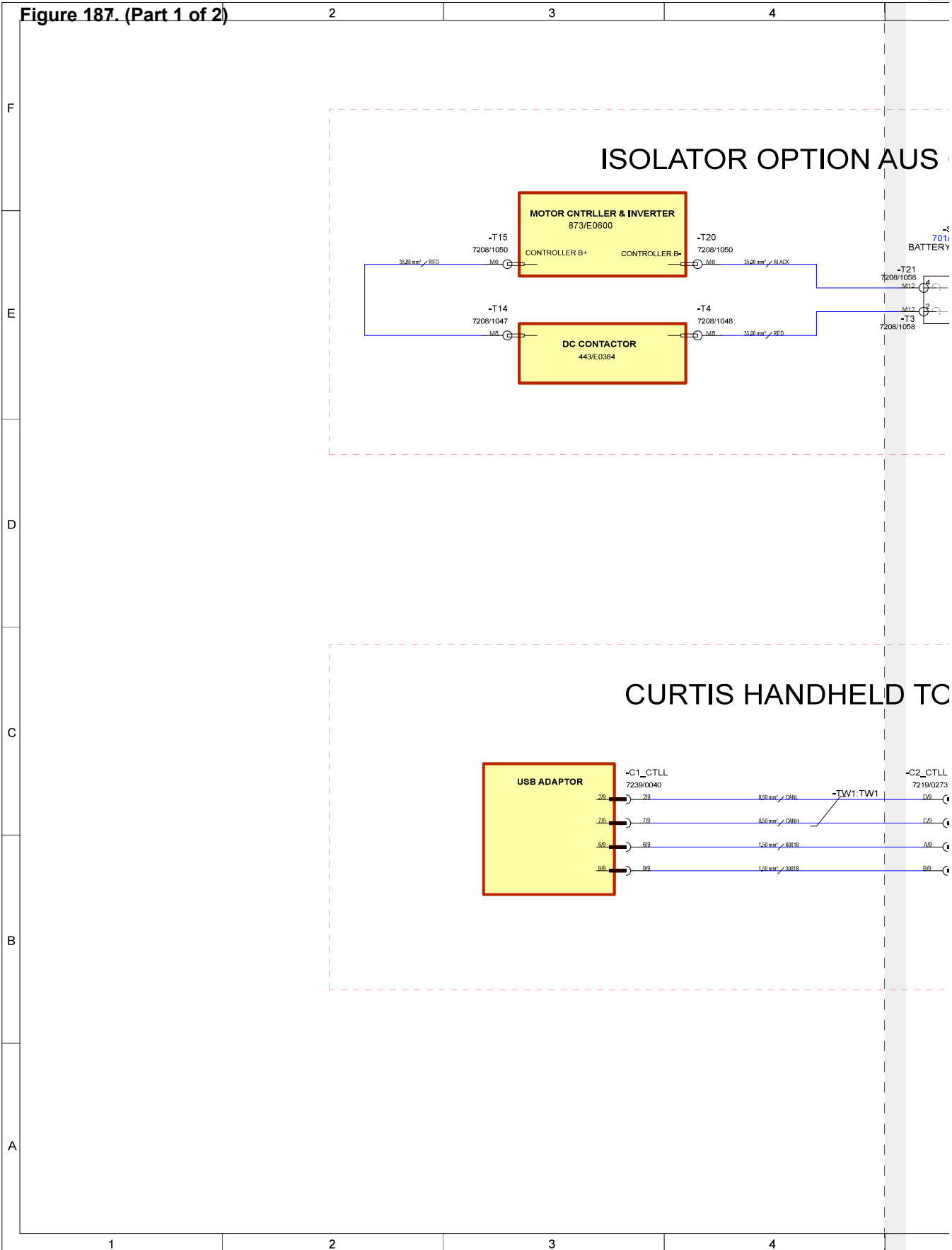
---

JCB © CONNOR STANMORE - 13/03/2026 07:57.



JCB © CONNOR STANMORE - 13/03/2026 07:57.

Figure 187. (Part 1 of 2)



Page 33-69

JCB © CONNOR STANMORE - 13/03/2026 07:57.

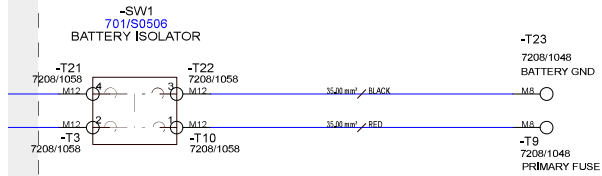
**Figure 187. (Part 2 of 2)**

6

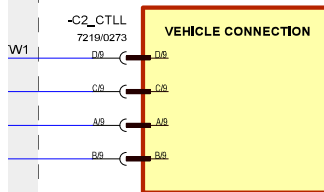
7

8

### JAUS ONLY


 F  
E  
D  
C  
B  
A

### LD TOOL LINK



873/E0155-10

5

6

7

8

JCB © CONNOR STANMORE - 13/03/2026 07:57.

Page 33-68



(For: S3246E EDRV [RAJ], S4046E EDRV [RAJ], S4550E EDRV [RAJ])

Figure 188. 873/E0179 Issue 8 (Sheet 1 of 15) - Electric Drive Scissors Schematic..... Page 33-71

Figure 189. 873/E0179 Issue 8 (Sheet 2 of 15) - Electric Drive Scissors Schematic..... Page 33-75

Figure 190. 873/E0179 Issue 8 (Sheet 3 of 15) - LiveLink ECU..... Page 33-79

Figure 191. 873/E0179 Issue 8 (Sheet 4 of 15) - CAN Network..... Page 33-83

Figure 192. 873/E0179 Issue 8 (Sheet 5 of 15) - Dual Zone..... Page 33-87

Figure 193. 873/E0179 Issue 8 (Sheet 6 of 15) - Over Rise Protection..... Page 33-91

Figure 194. 873/E0179 Issue 8 (Sheet 7 of 15) - Power Cable EU with RCBO..... Page 33-95

Figure 195. 873/E0179 Issue 8 (Sheet 8 of 15) - Power Cable UK RCBO..... Page 33-99

Figure 196. 873/E0179 Issue 8 (Sheet 9 of 15) - Power to Platform UK W/O RCBO..... Page 33-103

Figure 197. 873/E0179 Issue 8 (Sheet 10 of 15) - Power Cable with GFP and MCB..... Page 33-107

Figure 198. 873/E0179 Issue 8 (Sheet 11 of 15) - Power to Platform US W/O GFP and MCB..... Page 33-111

Figure 199. 873/E0179 Issue 8 (Sheet 12 of 15) - Power to Platform SCHUKO..... Page 33-115

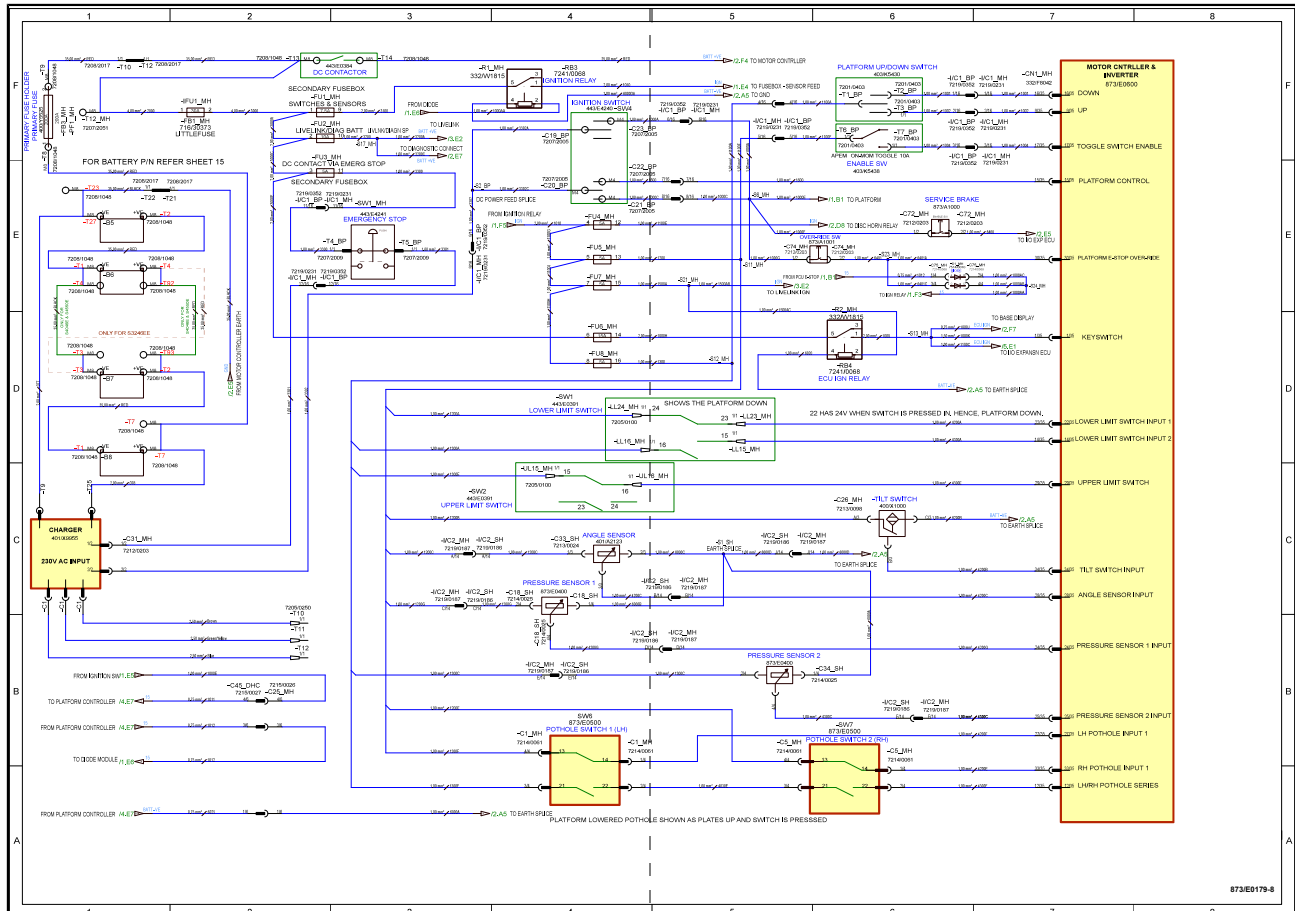
Figure 200. 873/E0179 Issue 8 (Sheet 13 of 15) - Angle Sensor Pig Tail..... Page 33-119

Figure 201. 873/E0179 Issue 8 (Sheet 14 of 15) - Isolator Battery Cable..... Page 33-123

Sheet 15 is not included as it only contains change log.

JCB © CONNOR STANMORE - 13/03/2026 07:57.

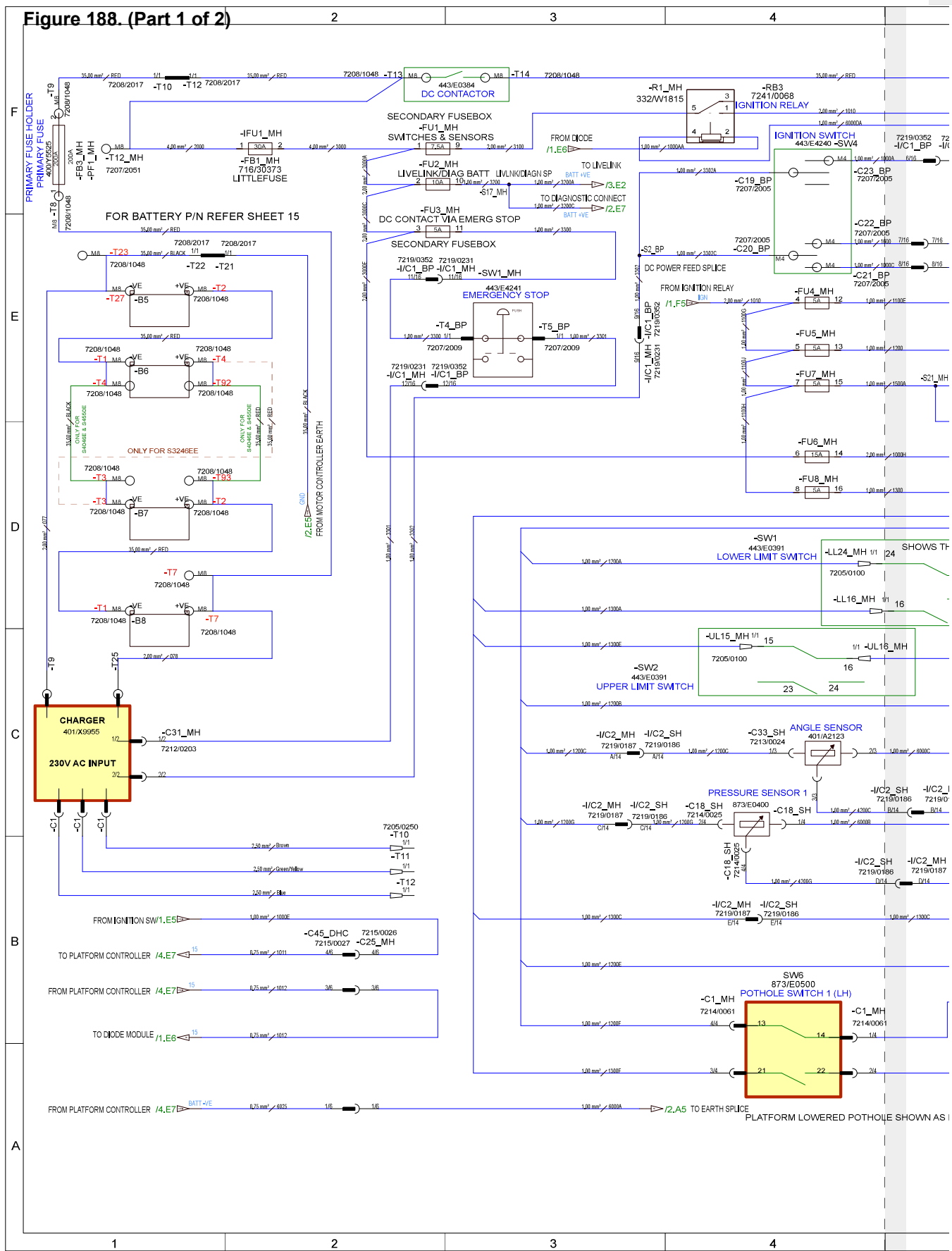
Figure 188. 873/E0179 Issue 8 (Sheet 1 of 15) - Electric Drive Scissors Schematic



JCB © CONNOR STANMORE - 13/03/2026 07:57.



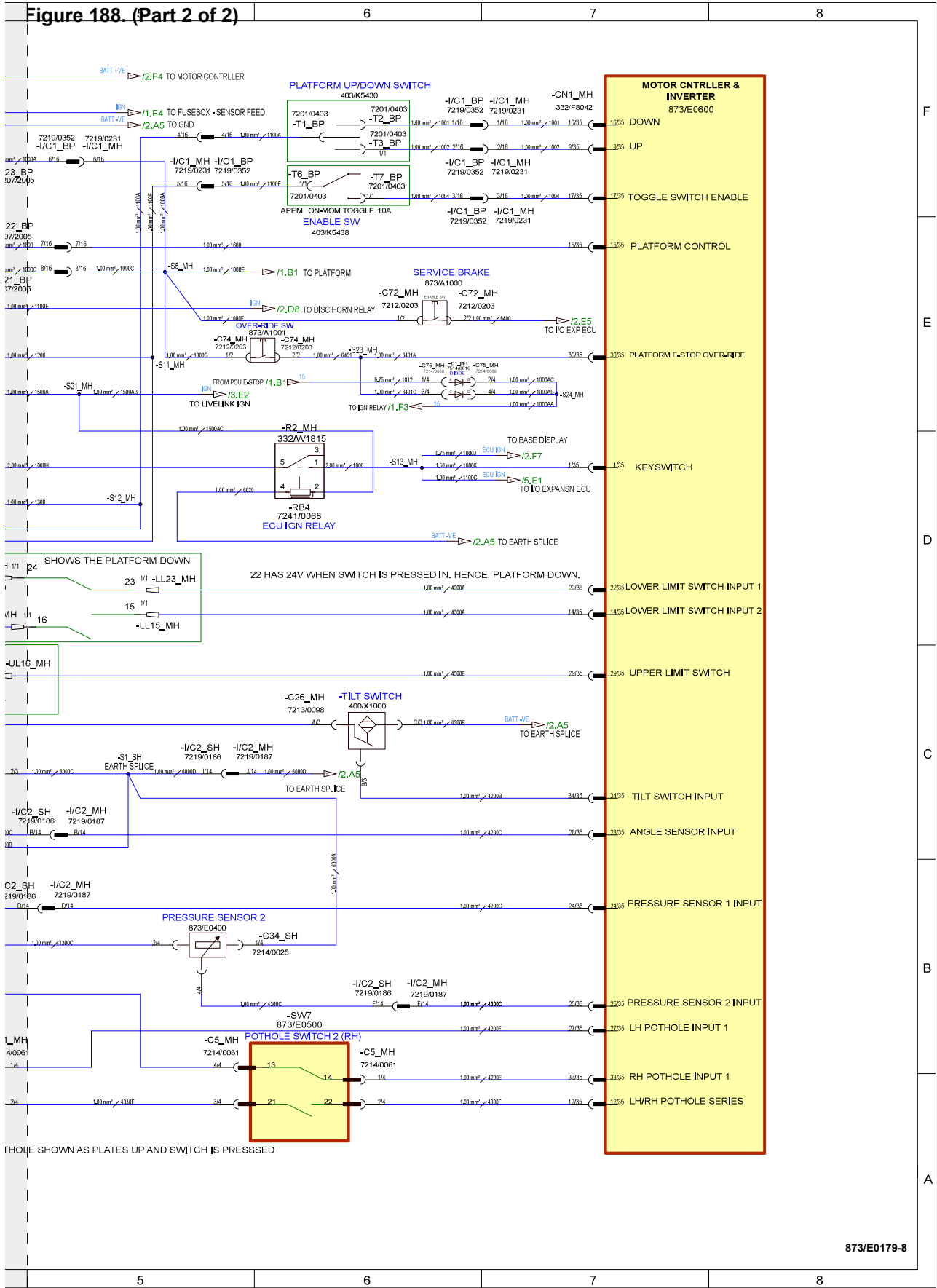
Figure 188. (Part 1 of 2)



Page 33-73

JCB © CONNOR STANMORE - 13/03/2026 07:57.

**Figure 188. (Part 2 of 2)**



873/E0179-8

JCB © CONNOR STANMORE - 13/03/2026 07:57.



## 33 - Electrical System

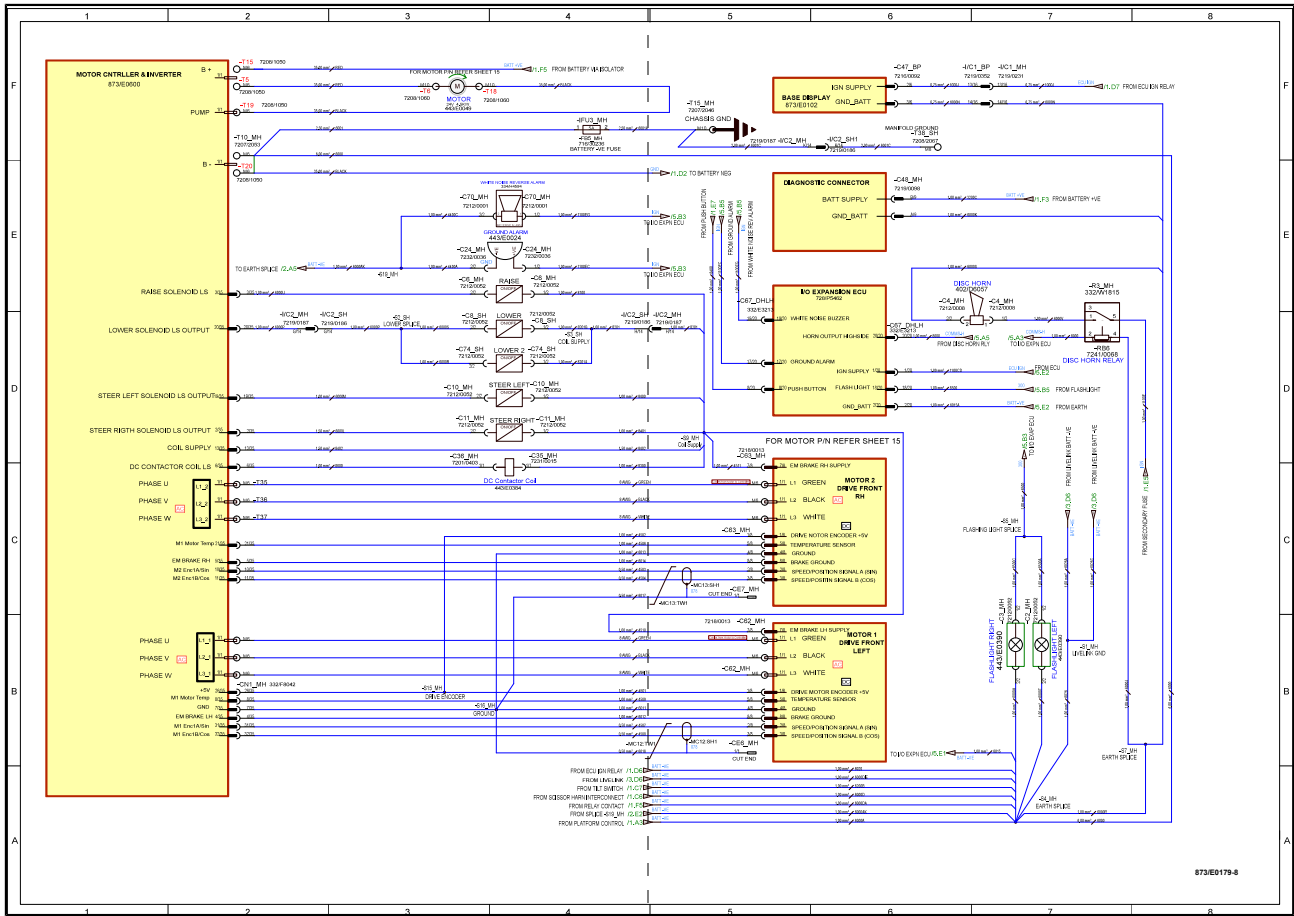
00 - Electrical System

50 - Schematic Circuit

---

JCB © CONNOR STANMORE - 13/03/2026 07:57.

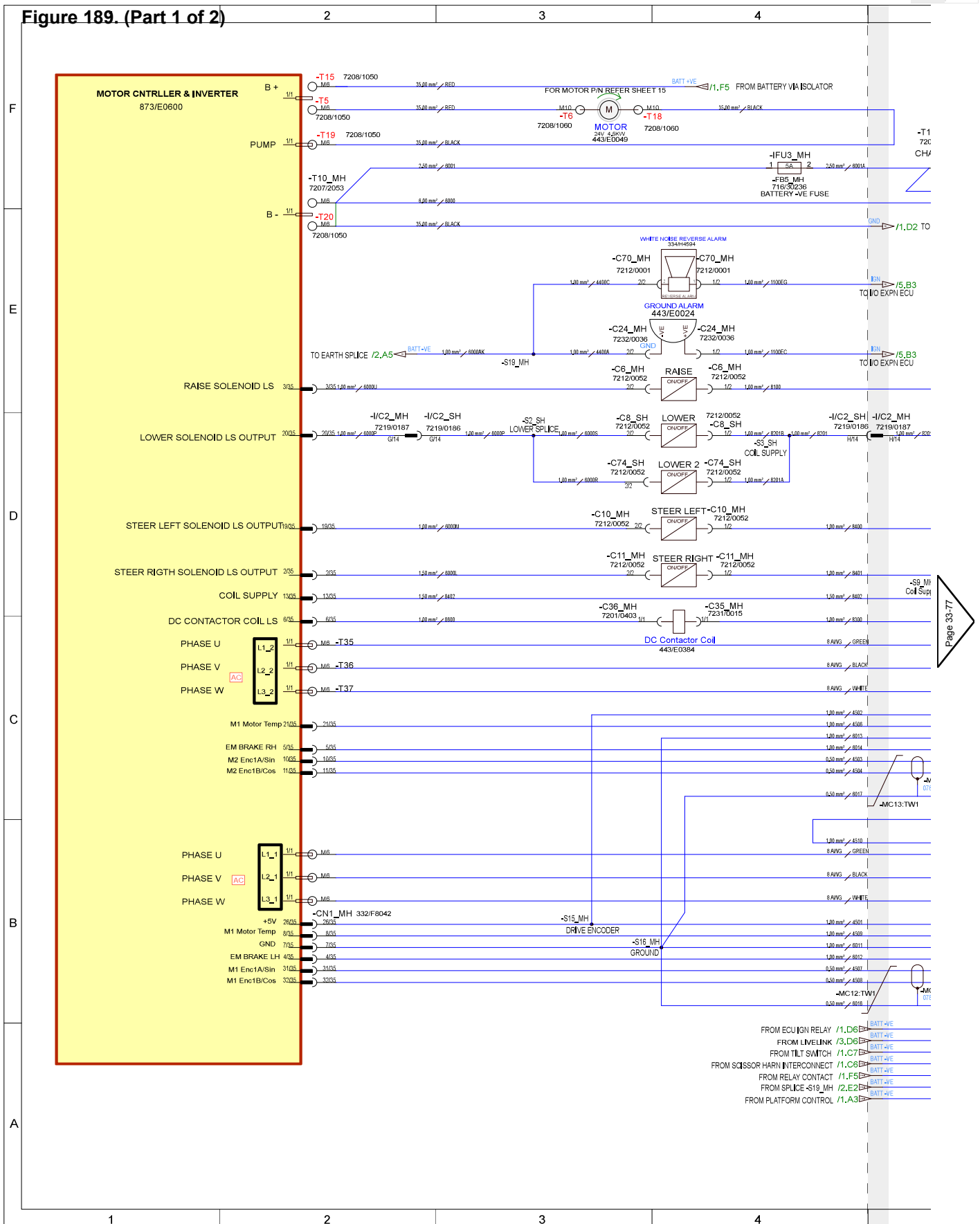
Figure 189. 873/E0179 Issue 8 (Sheet 2 of 15) - Electric Drive Scissors Schematic



JCB © CONNOR STANMORE - 13/03/2026 07:57.



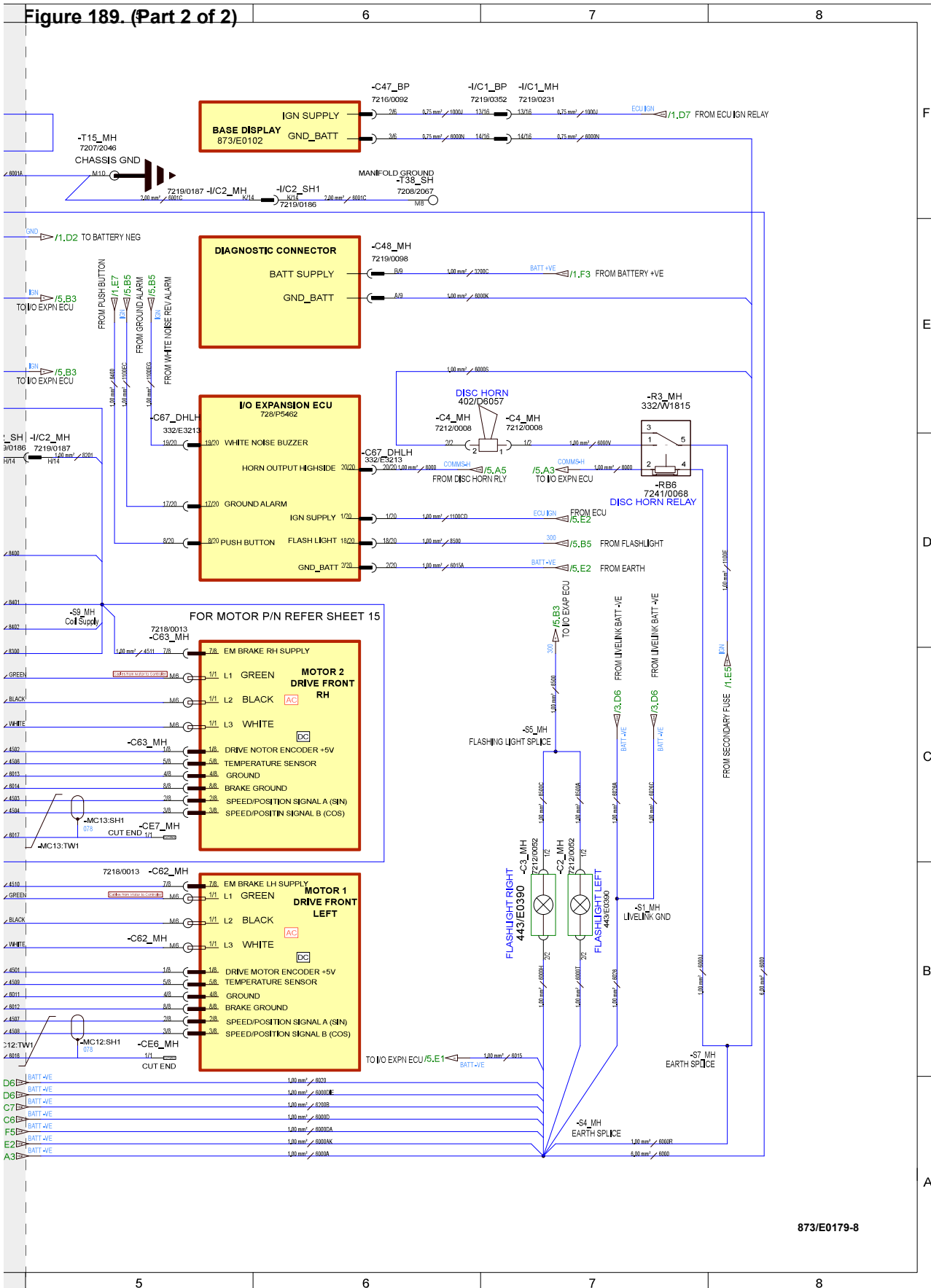
Figure 189. (Part 1 of 2)



JCB © CONNOR STANMORE - 13/03/2026 07:57.

Page 33-77

### Figure 189. (Part 2 of 2)



873/E0179-8

JCB © CONNOR STANMORE - 13/03/2026 07:57.



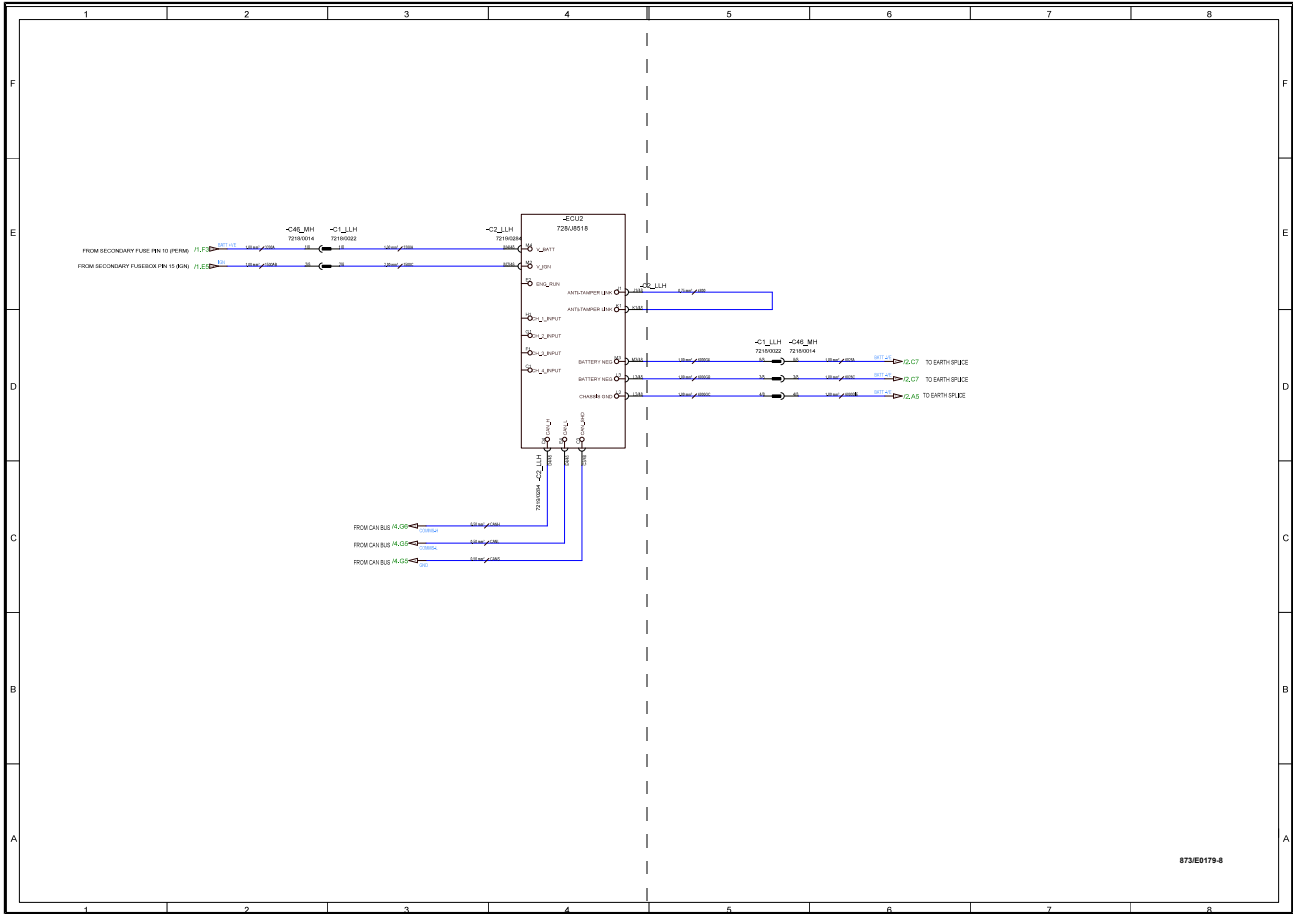
## 33 - Electrical System

00 - Electrical System

50 - Schematic Circuit

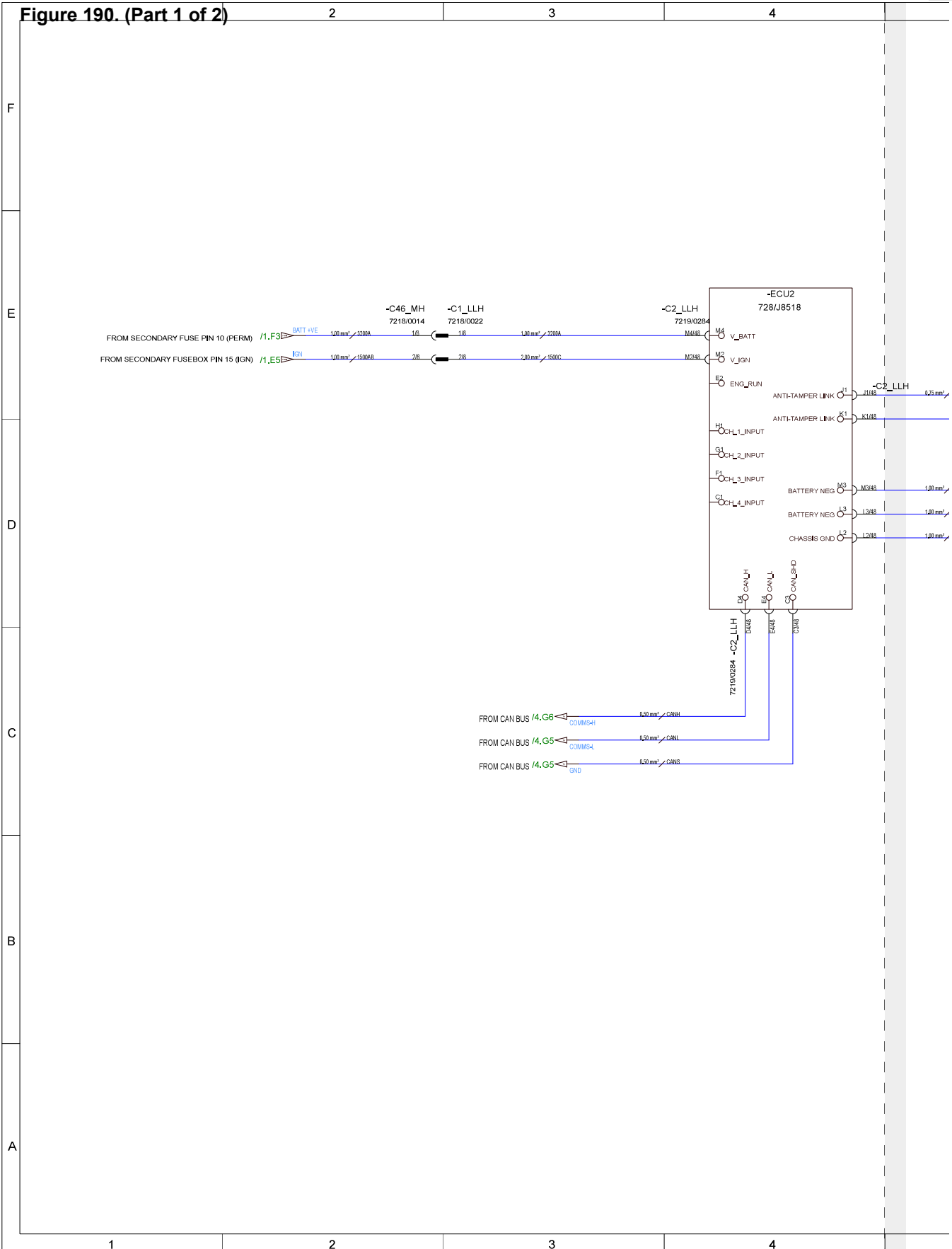
---

JCB © CONNOR STANMORE - 13/03/2026 07:57.



JCB © CONNOR STANMORE - 13/03/2026 07:57.

Figure 190. (Part 1 of 2)



Page 33-81

JCB © CONNOR STANMORE - 13/03/2026 07:57.

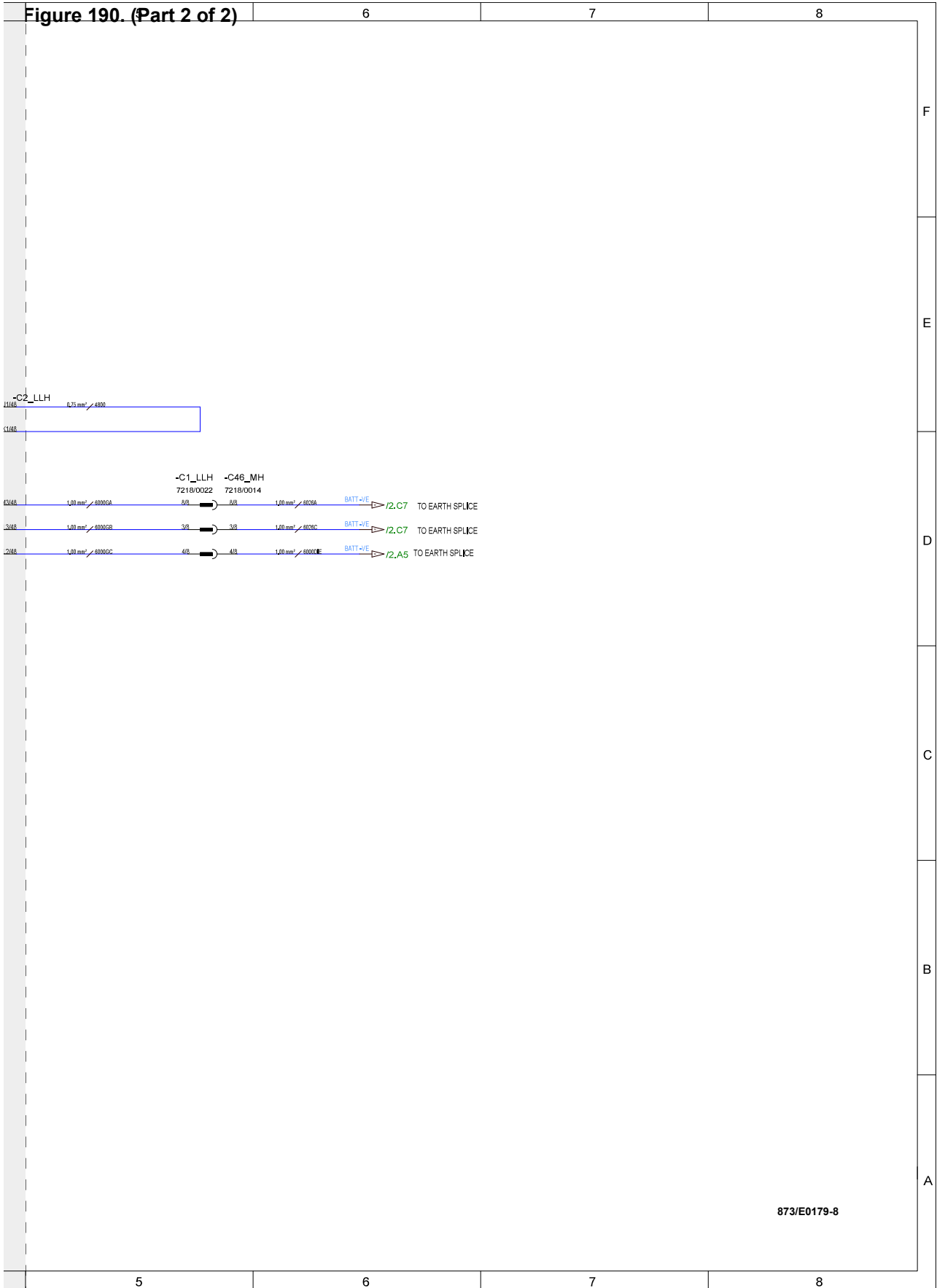


# 33 - Electrical System

00 - Electrical System

50 - Schematic Circuit

Figure 190. (Part 2 of 2)



Page 33-80

JCB © CONNOR STANMORE - 13/03/2026 07:57.



## 33 - Electrical System

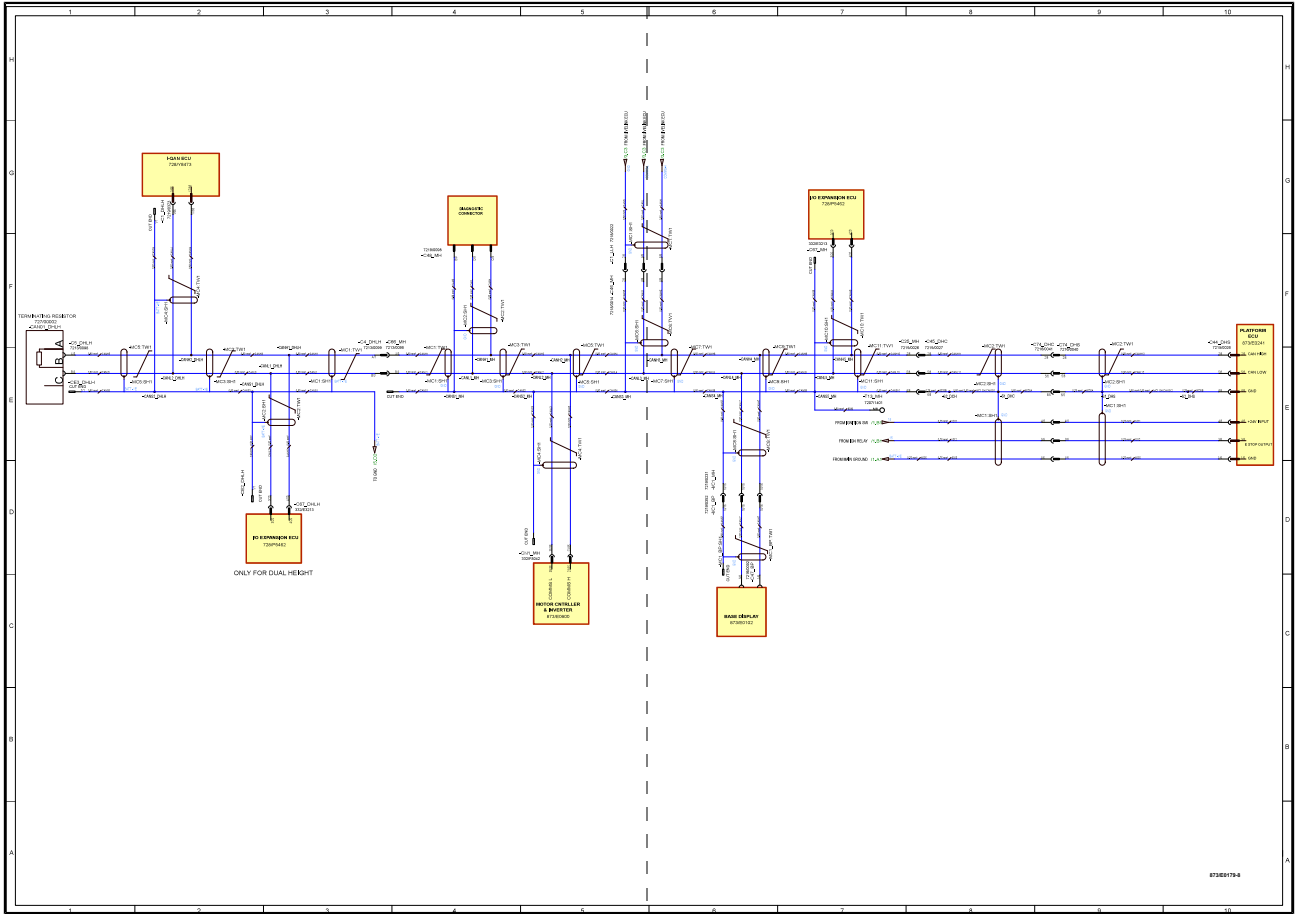
00 - Electrical System

50 - Schematic Circuit

---

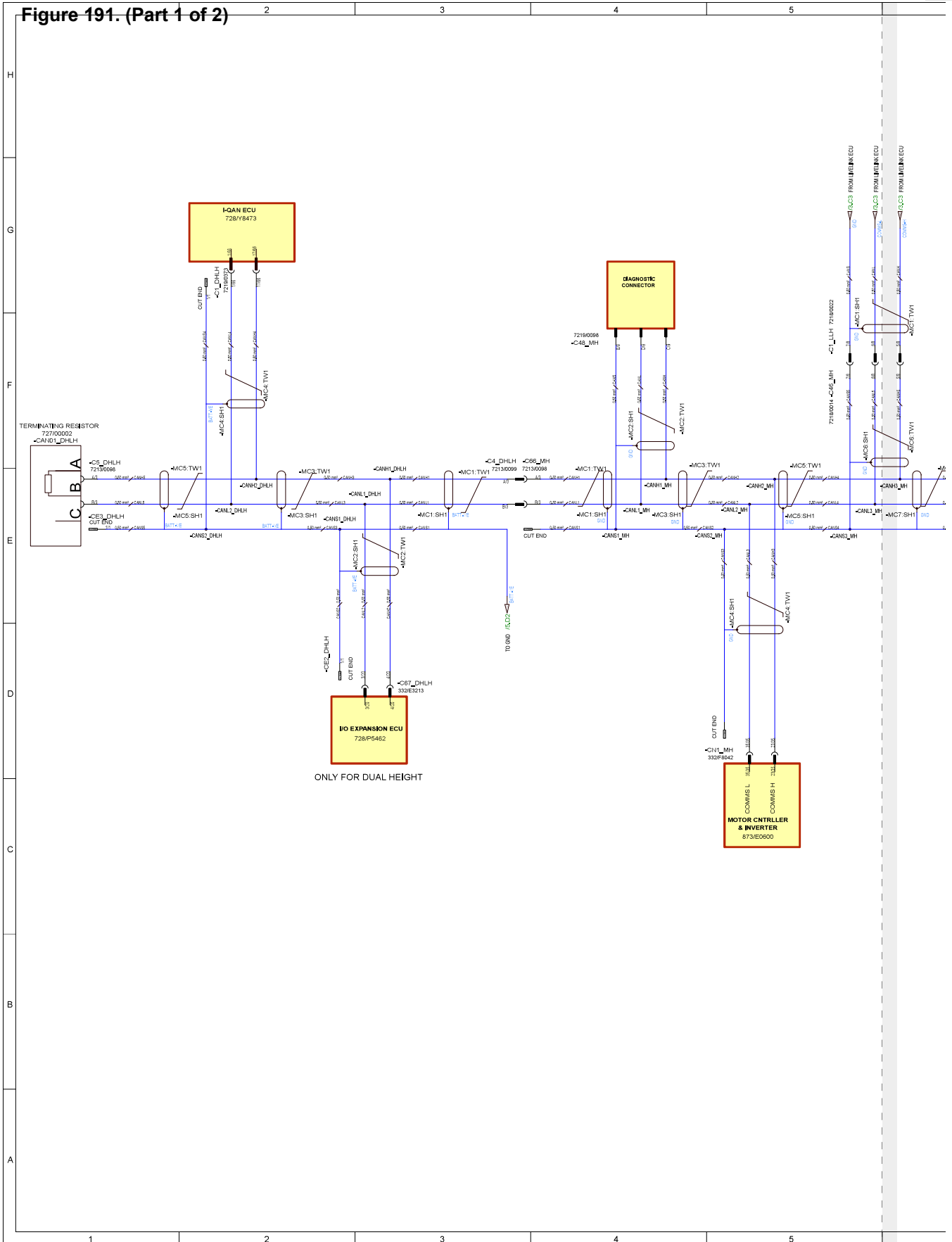
JCB © CONNOR STANMORE - 13/03/2026 07:57.

Figure 191. 873/E0179 Issue 8  
(Sheet 4 of 15) - CAN Network



JCB © CONNOR STANMORE - 13/03/2026 07:57.

Figure 191. (Part 1 of 2)

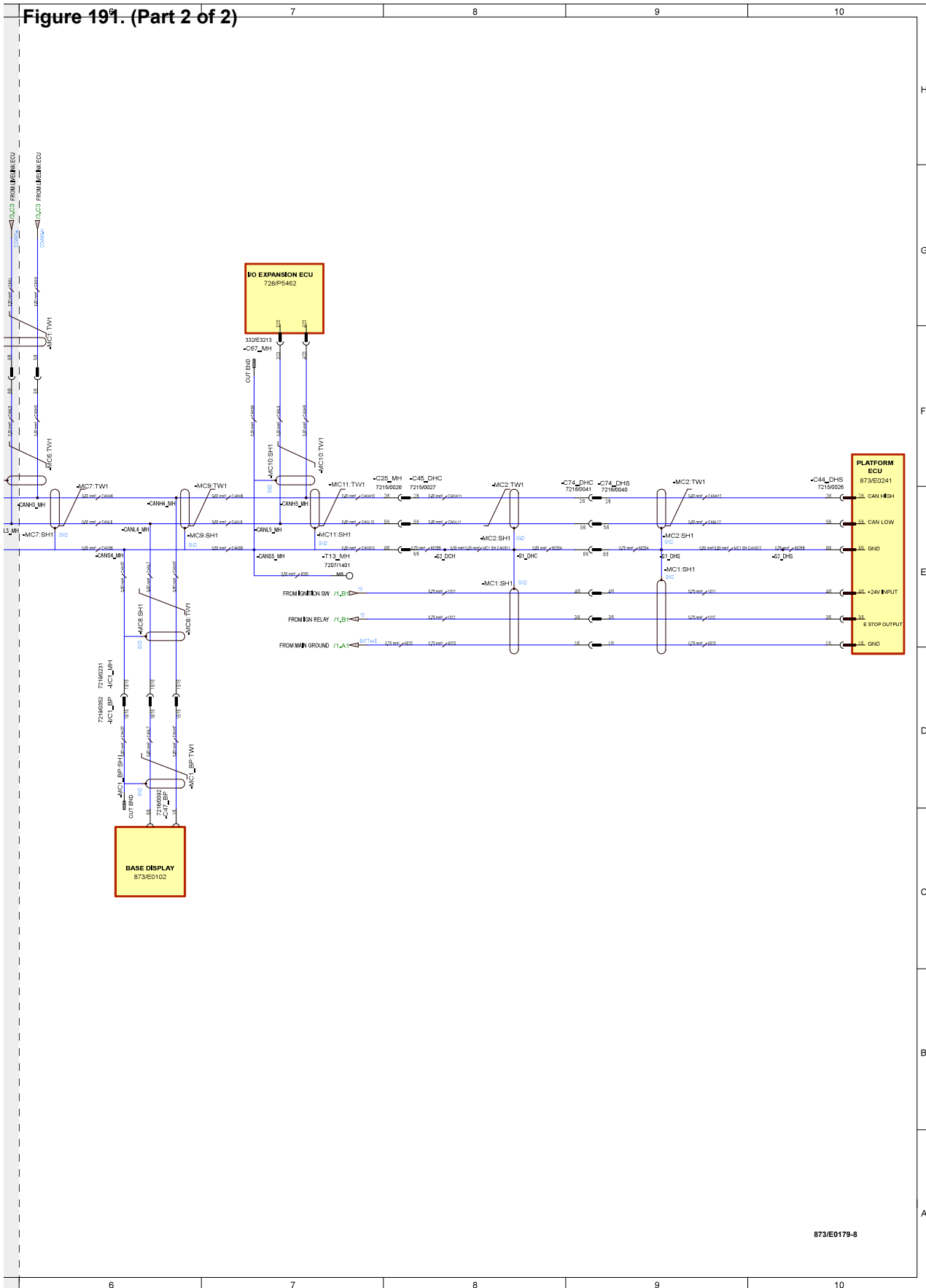


Page 33-85

JCB © CONNOR STANMORE - 13/03/2026 07:57.



Figure 191. (Part 2 of 2)



JCB © CONNOR STANMORE - 13/03/2026 07:57.

Page 33-84



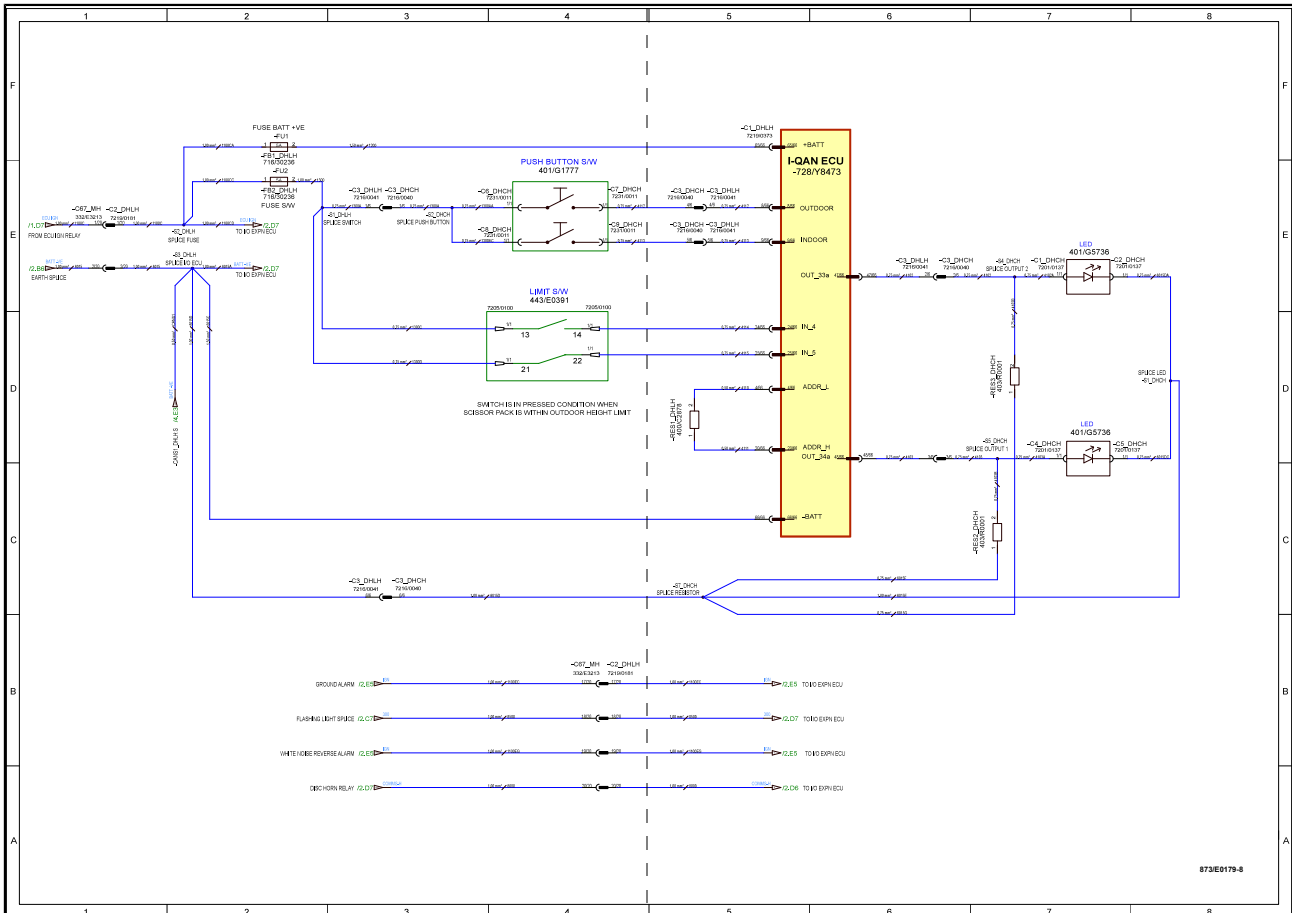
## 33 - Electrical System

00 - Electrical System

50 - Schematic Circuit

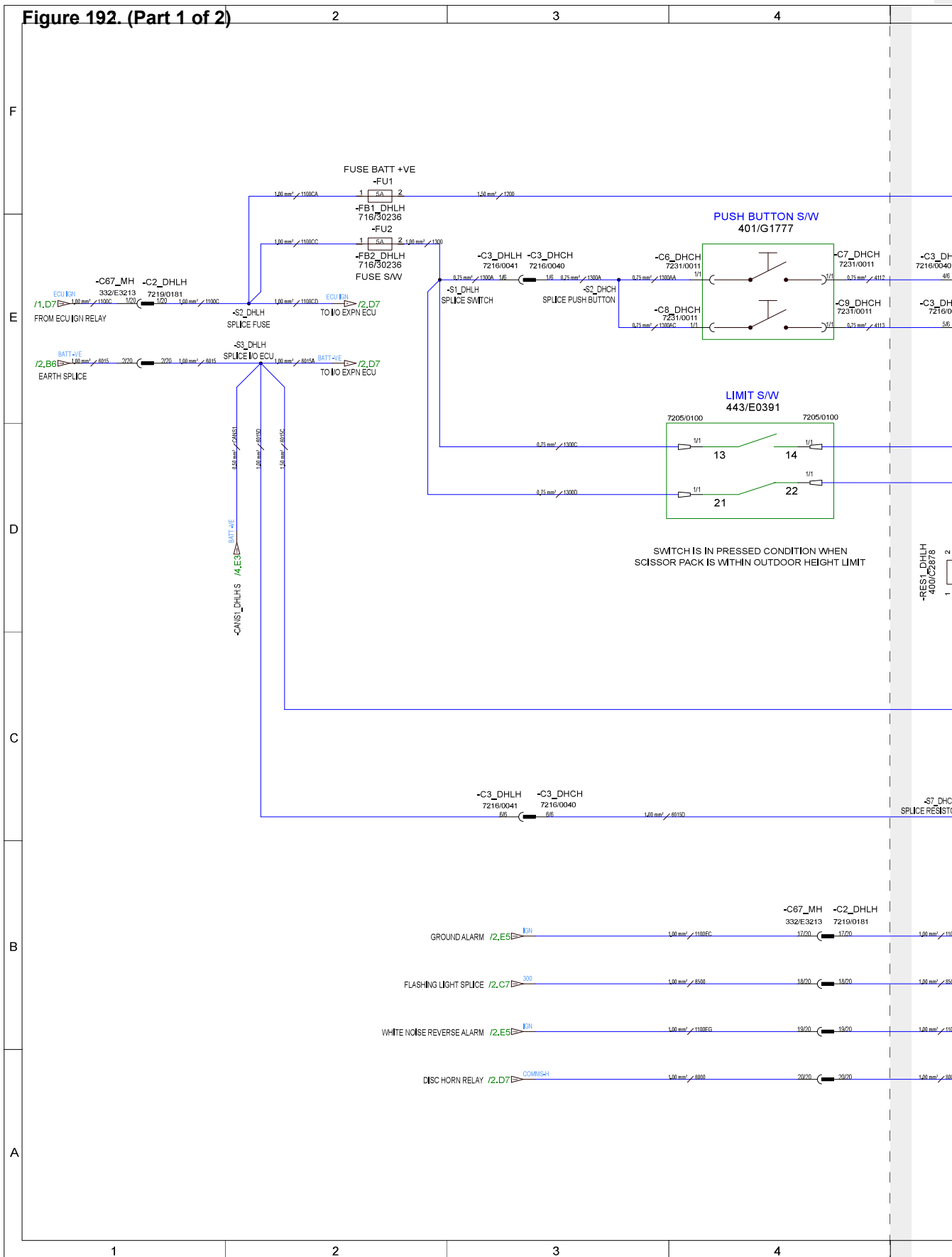
---

JCB © CONNOR STANMORE - 13/03/2026 07:57.



JCB © CONNOR STANMORE - 13/03/2026 07:57.

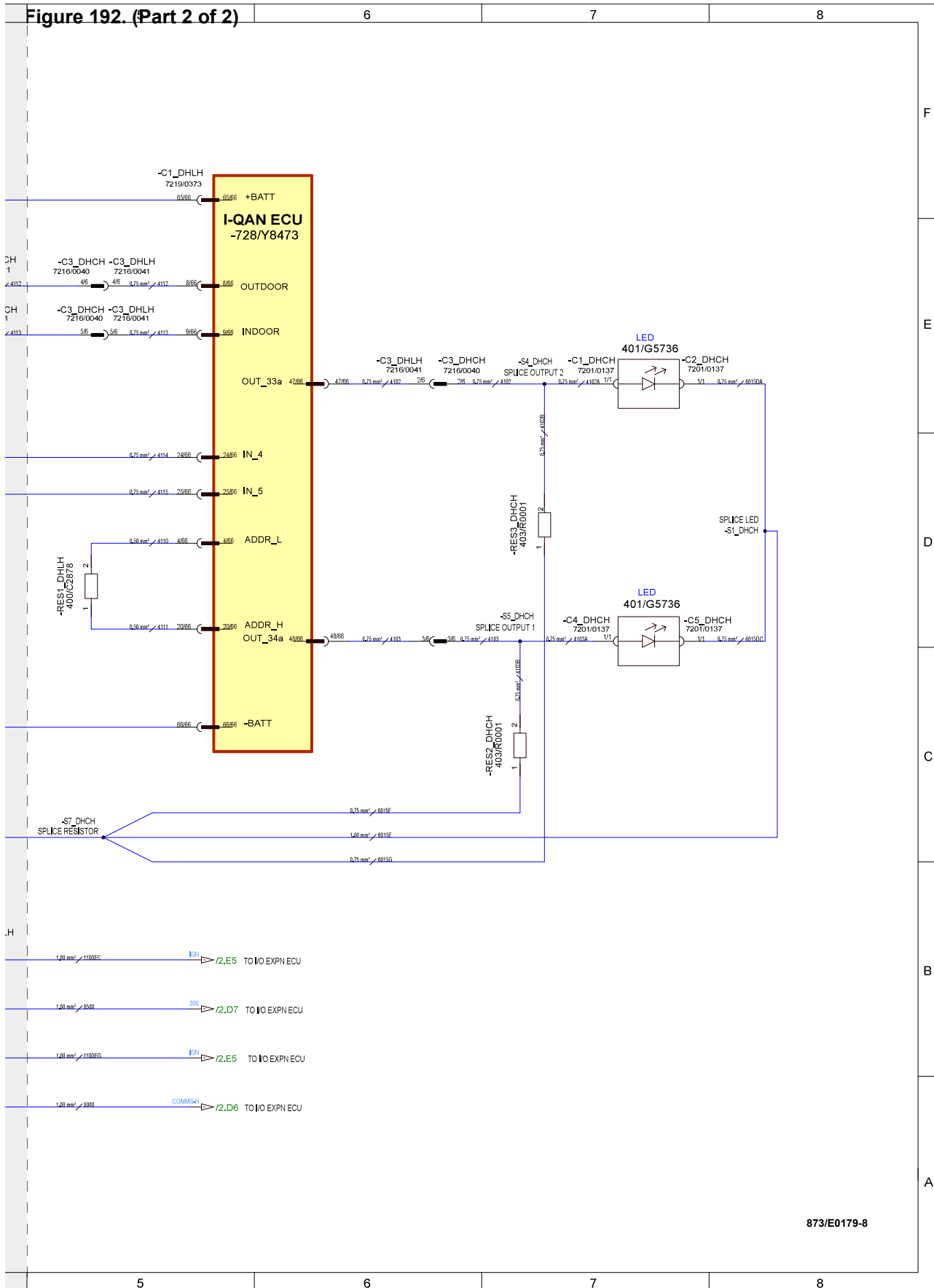
**Figure 192. (Part 1 of 2)**



JCB © CONNOR STANMORE - 13/03/2026 07:57.

Page 33-89

Figure 192. (Part 2 of 2)



873/E0179-8



## 33 - Electrical System

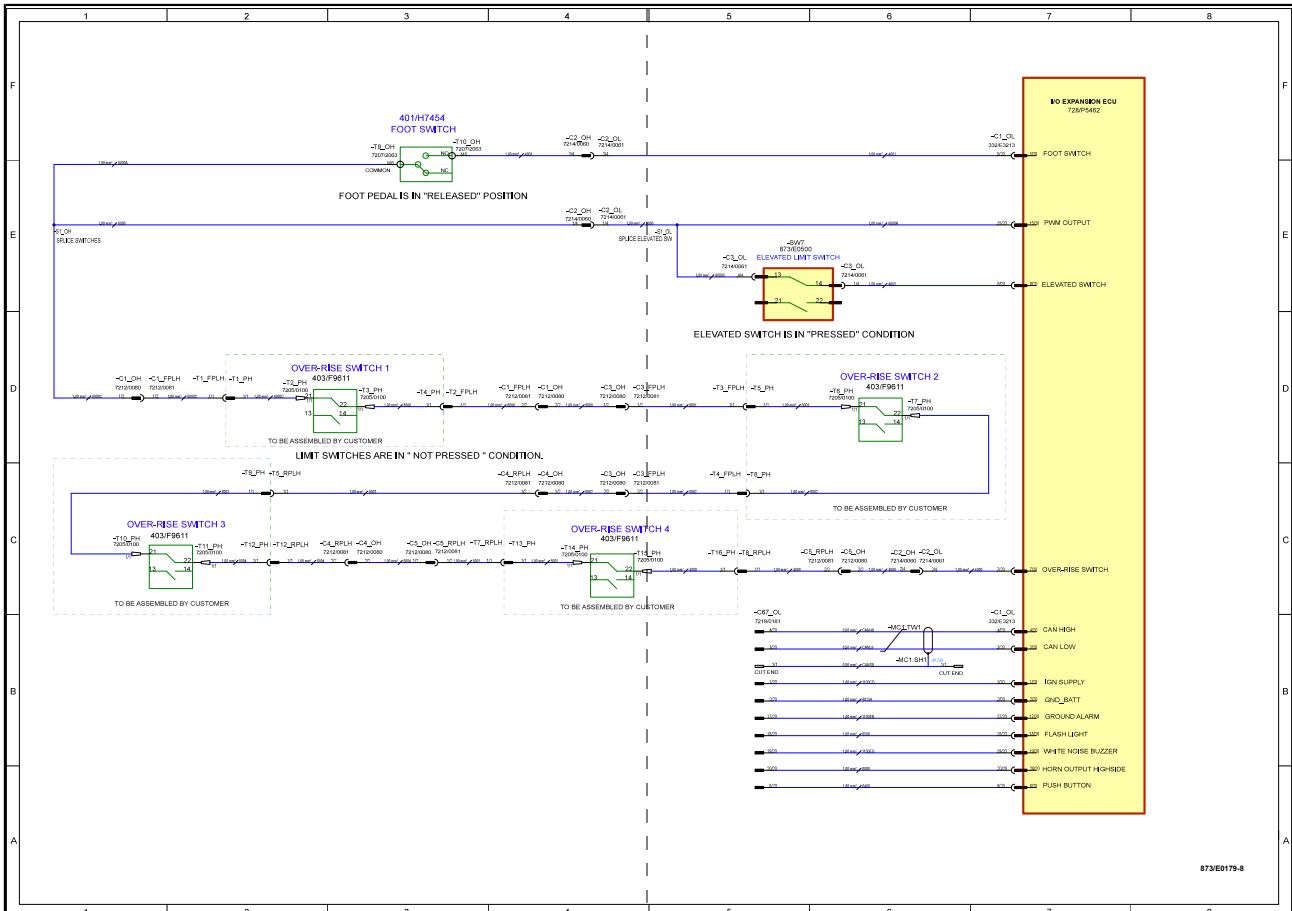
00 - Electrical System

50 - Schematic Circuit

---

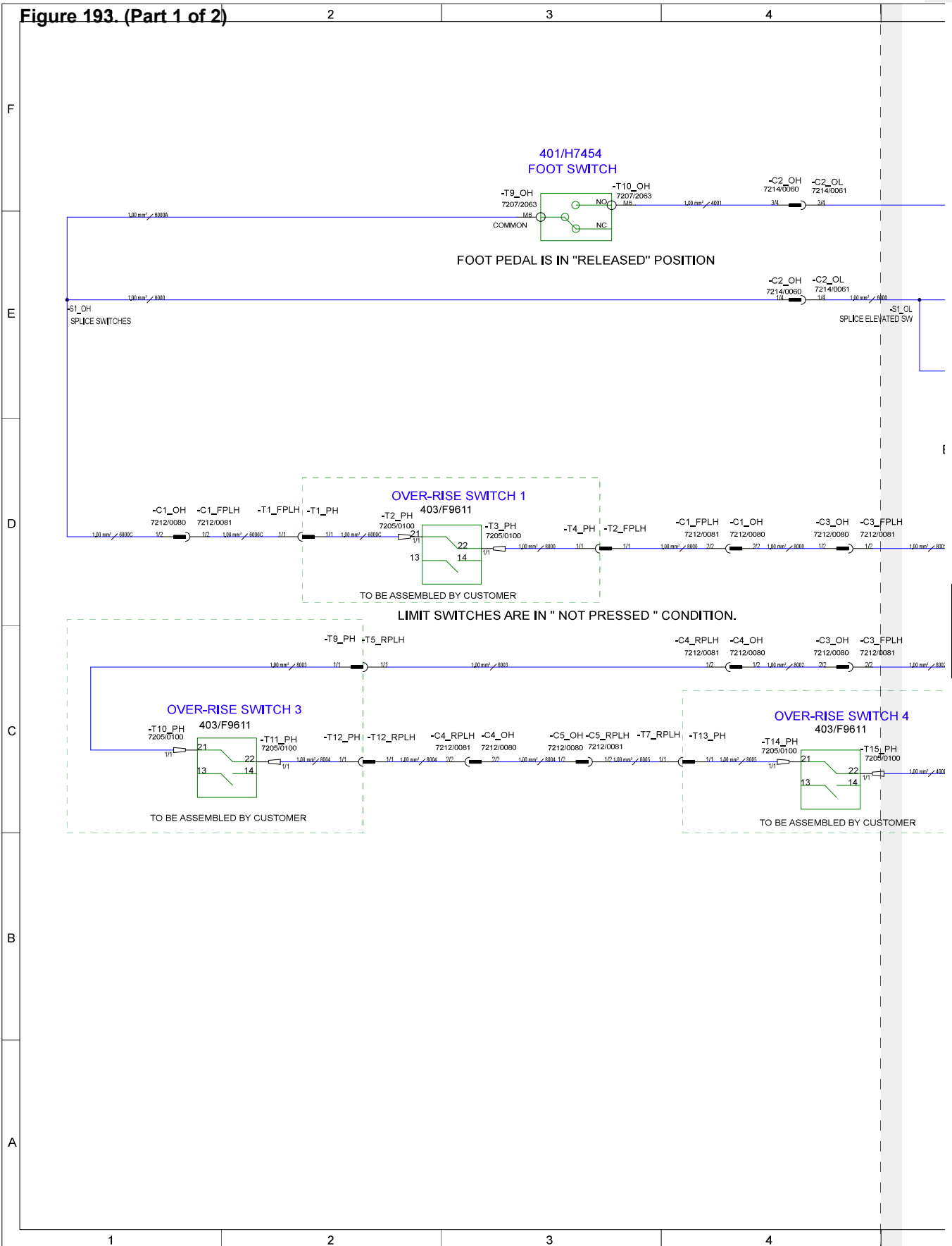
JCB © CONNOR STANMORE - 13/03/2026 07:57.

Figure 193. 873/E0179 Issue 8 (Sheet 6 of 15) - Over Rise Protection



JCB © CONNOR STANMORE - 13/03/2026 07:57.

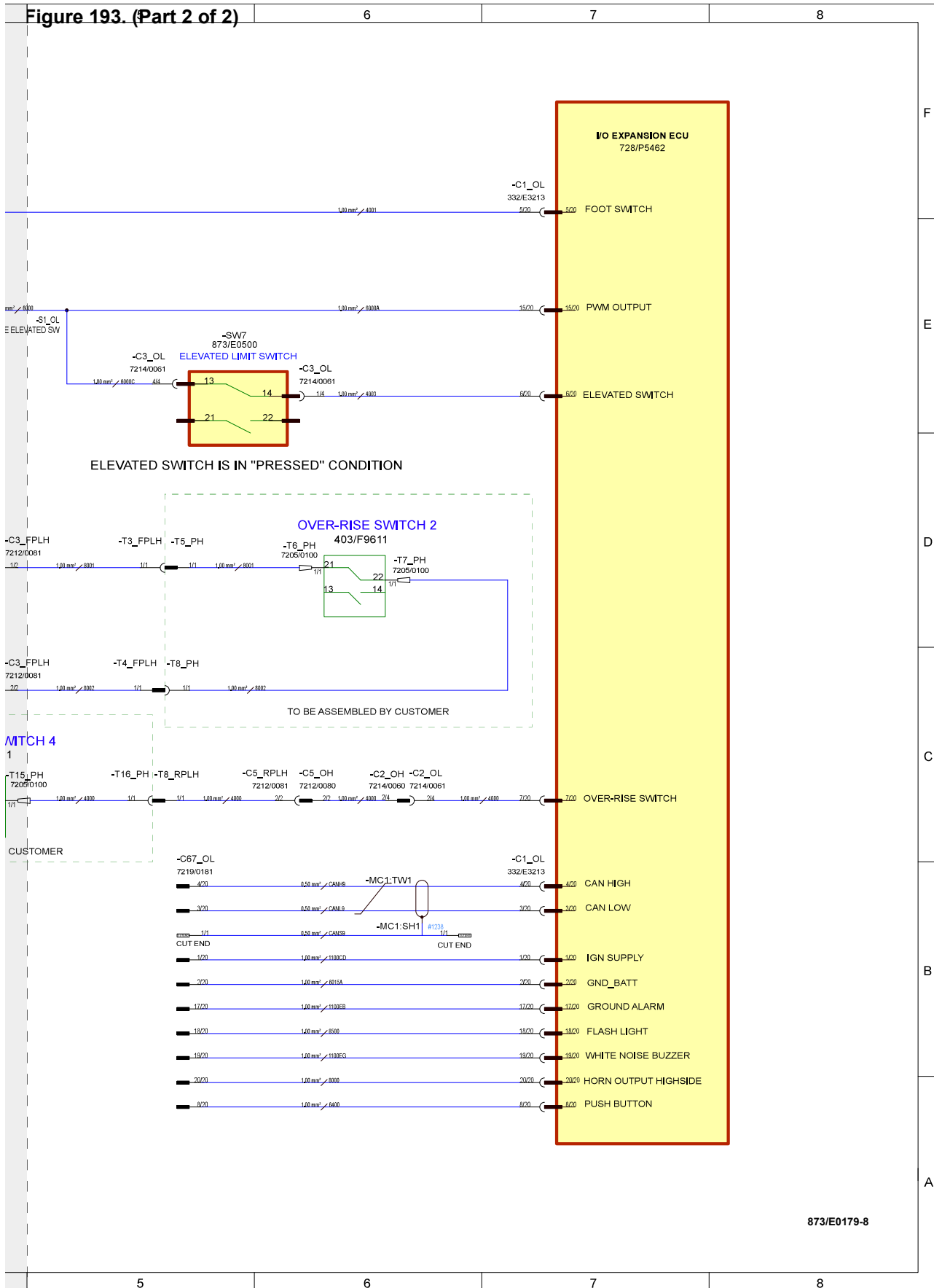
**Figure 193. (Part 1 of 2)**



Page 33-93

JCB © CONNOR STANMORE - 13/03/2026 07:57.

Figure 193. (Part 2 of 2)



873/E0179-8

JCB © CONNOR STANMORE - 13/03/2026 07:57.



## 33 - Electrical System

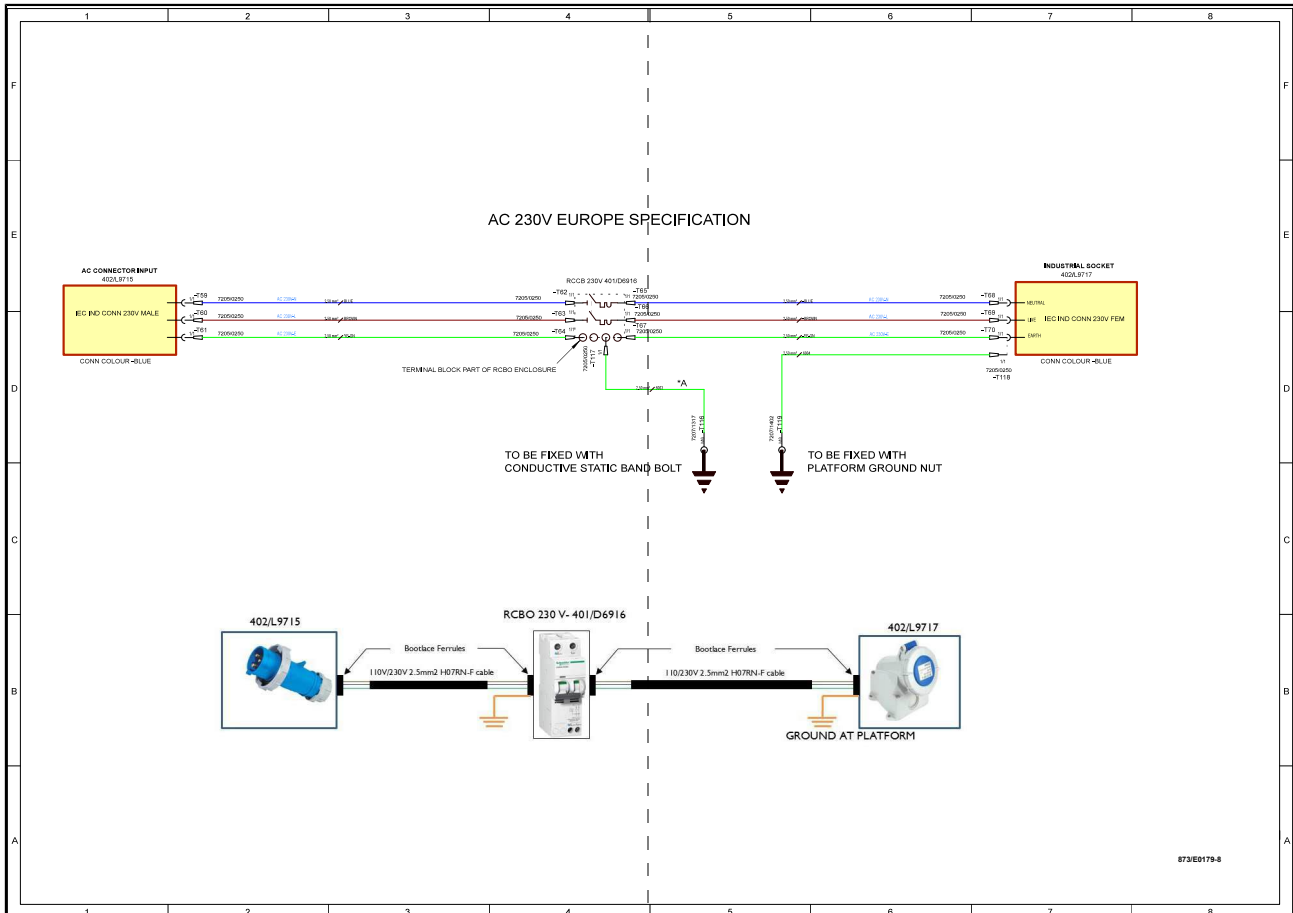
00 - Electrical System

50 - Schematic Circuit

---

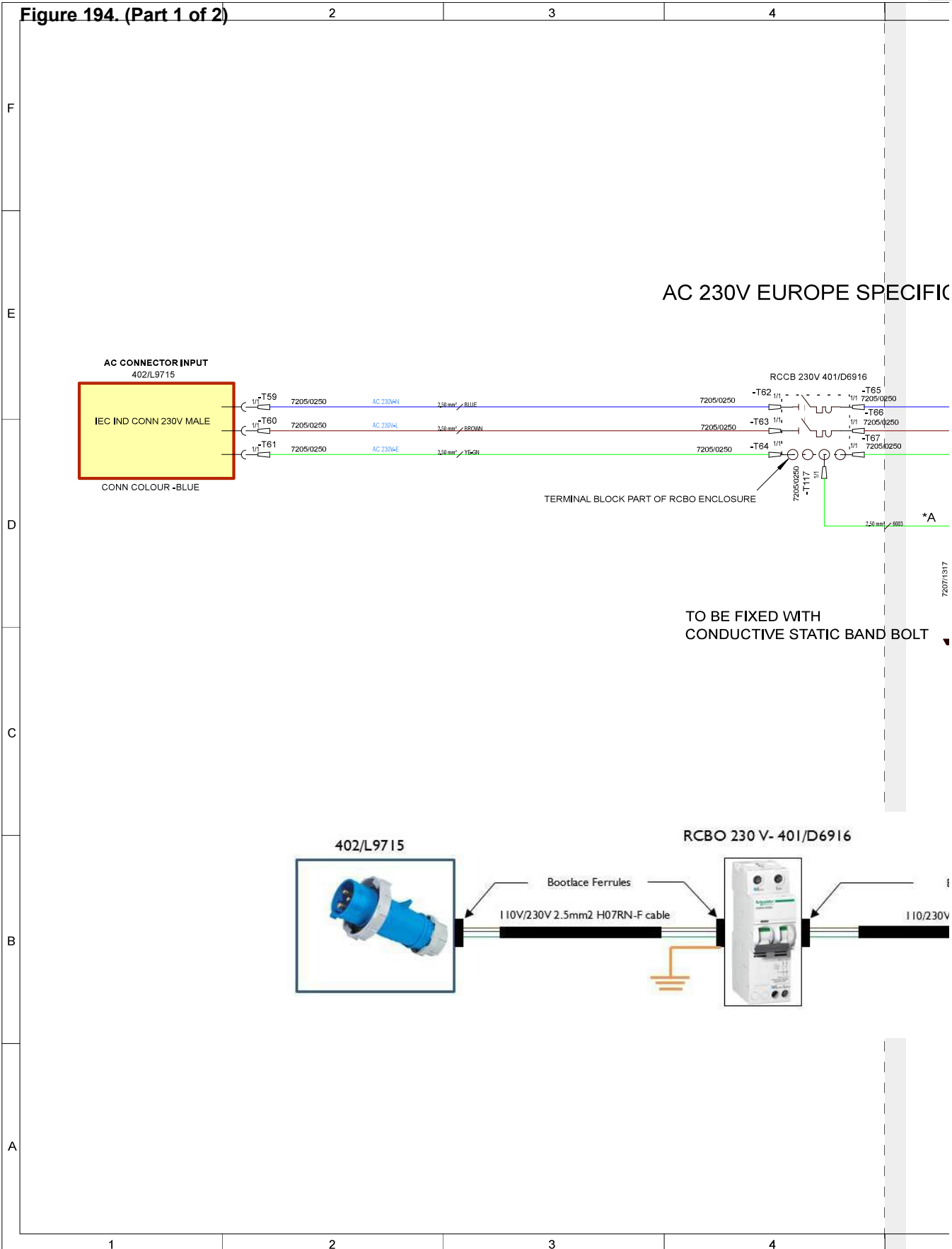
JCB © CONNOR STANMORE - 13/03/2026 07:57.

**Figure 194. 873/E0179 Issue 8 (Sheet 7 of 15) - Power Cable EU with RCBO**



JCB © CONNOR STANMORE - 13/03/2026 07:57.

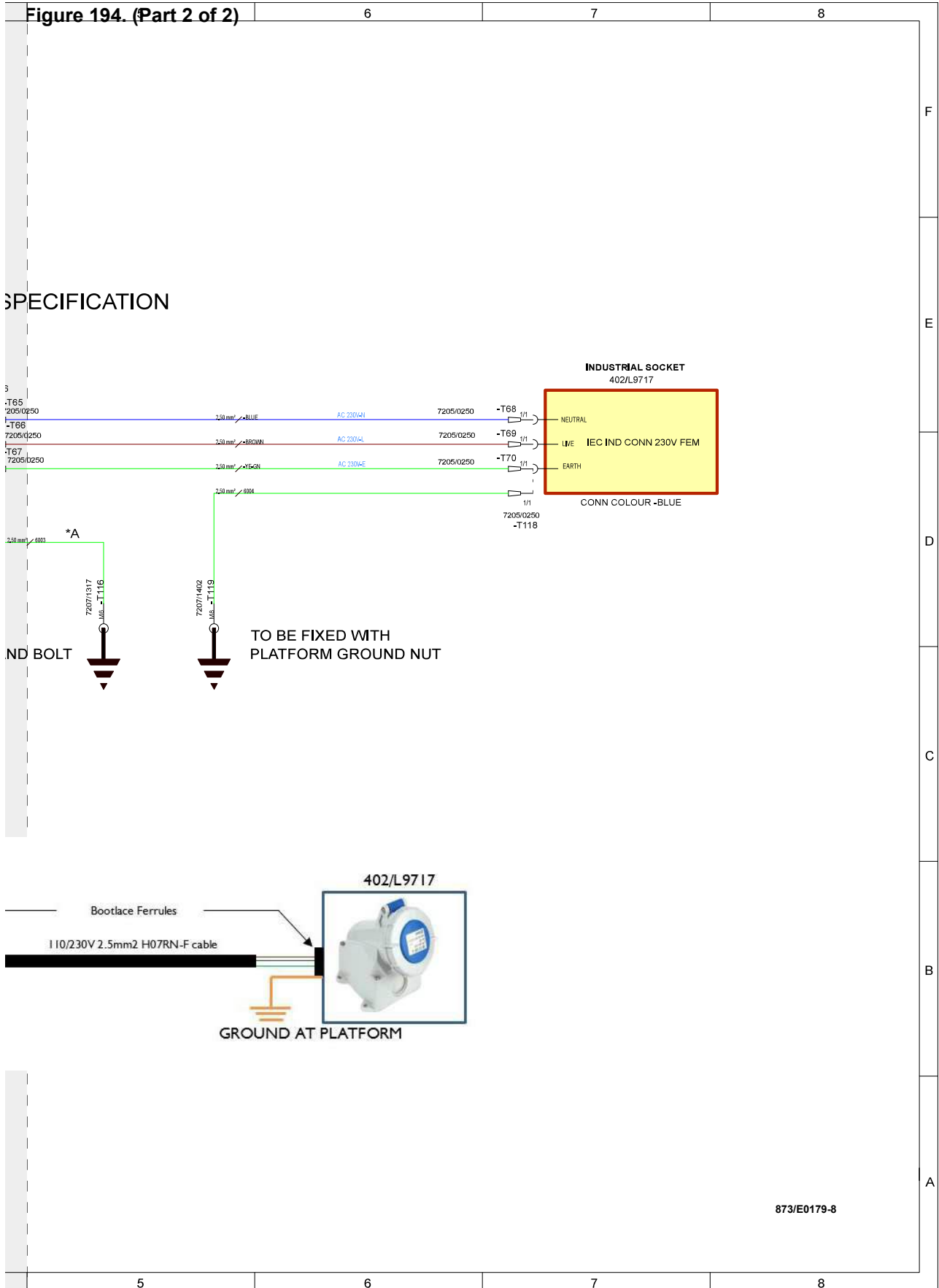
**Figure 194. (Part 1 of 2)**



JCB © CONNOR STANMORE - 13/03/2026 07:57.

7207/1317  
Page 33-97

Figure 194. (Part 2 of 2)



JCB © CONNOR STANMORE - 13/03/2026 07:57.



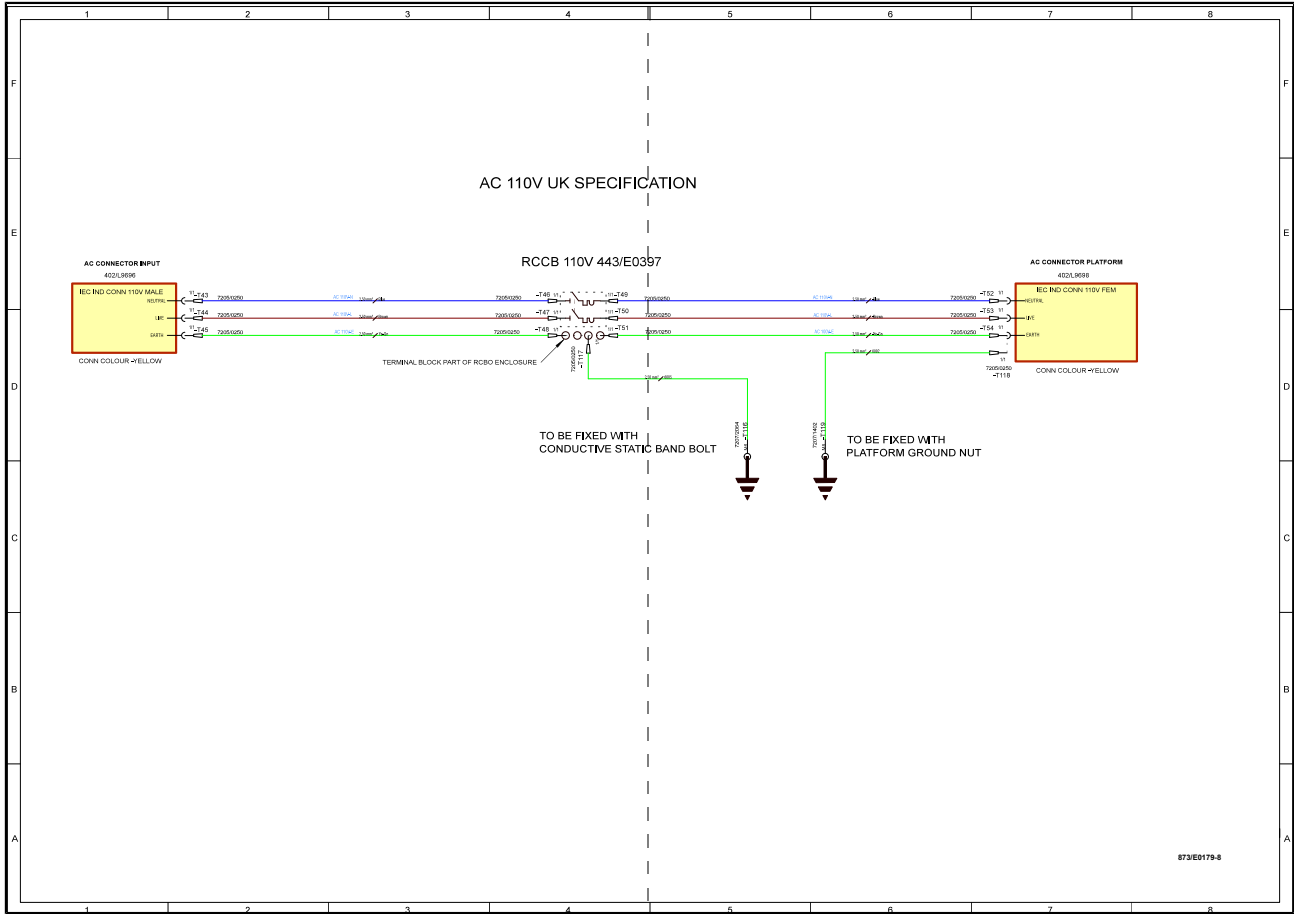
## 33 - Electrical System

00 - Electrical System

50 - Schematic Circuit

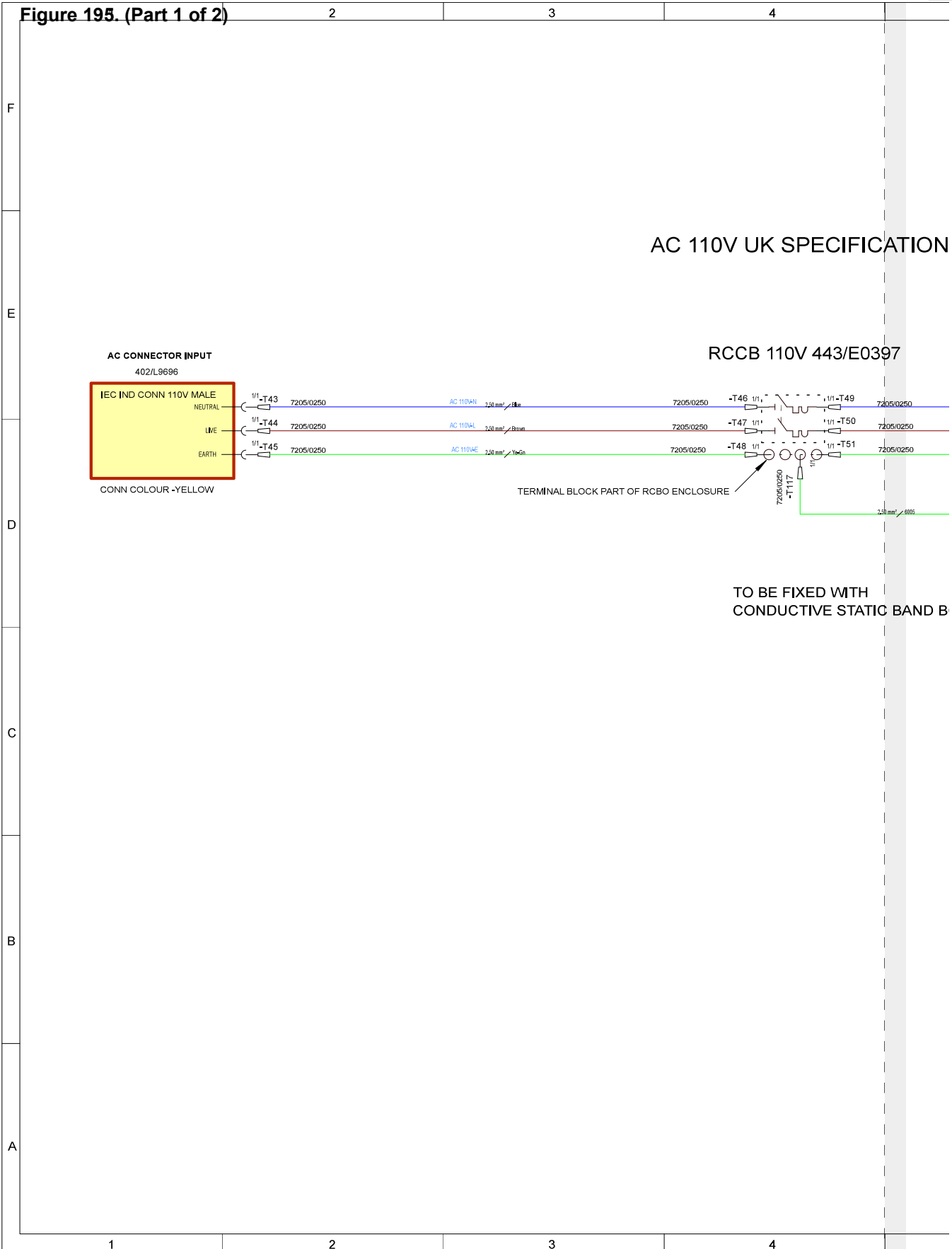
---

JCB © CONNOR STANMORE - 13/03/2026 07:57.



JCB © CONNOR STANMORE - 13/03/2026 07:57.

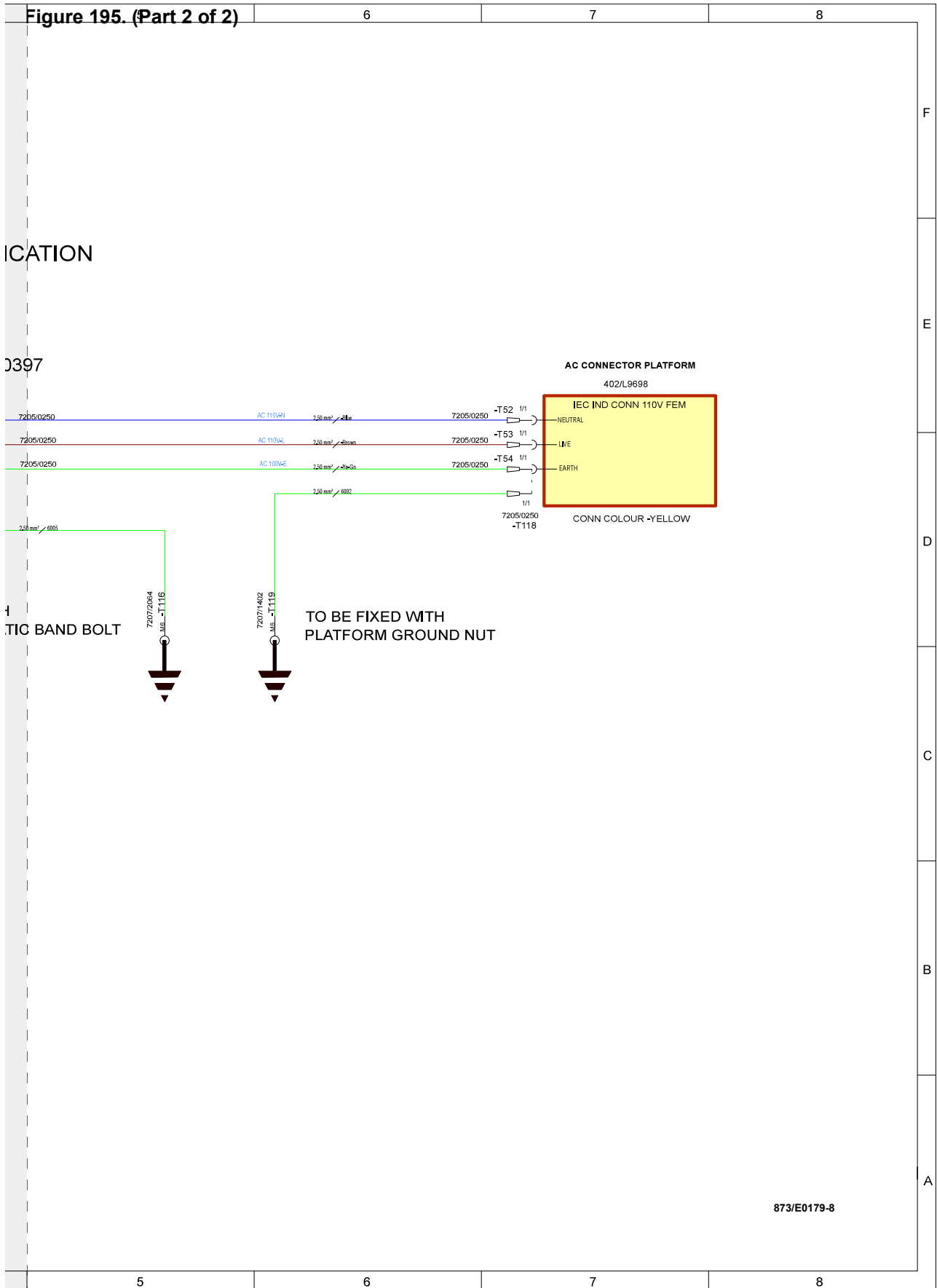
Figure 195. (Part 1 of 2)



JCB © CONNOR STANMORE - 13/03/2026 07:57.

Page 33-101

Figure 195. (Part 2 of 2)



JCB © CONNOR STANMORE - 13/03/2026 07:57.



## 33 - Electrical System

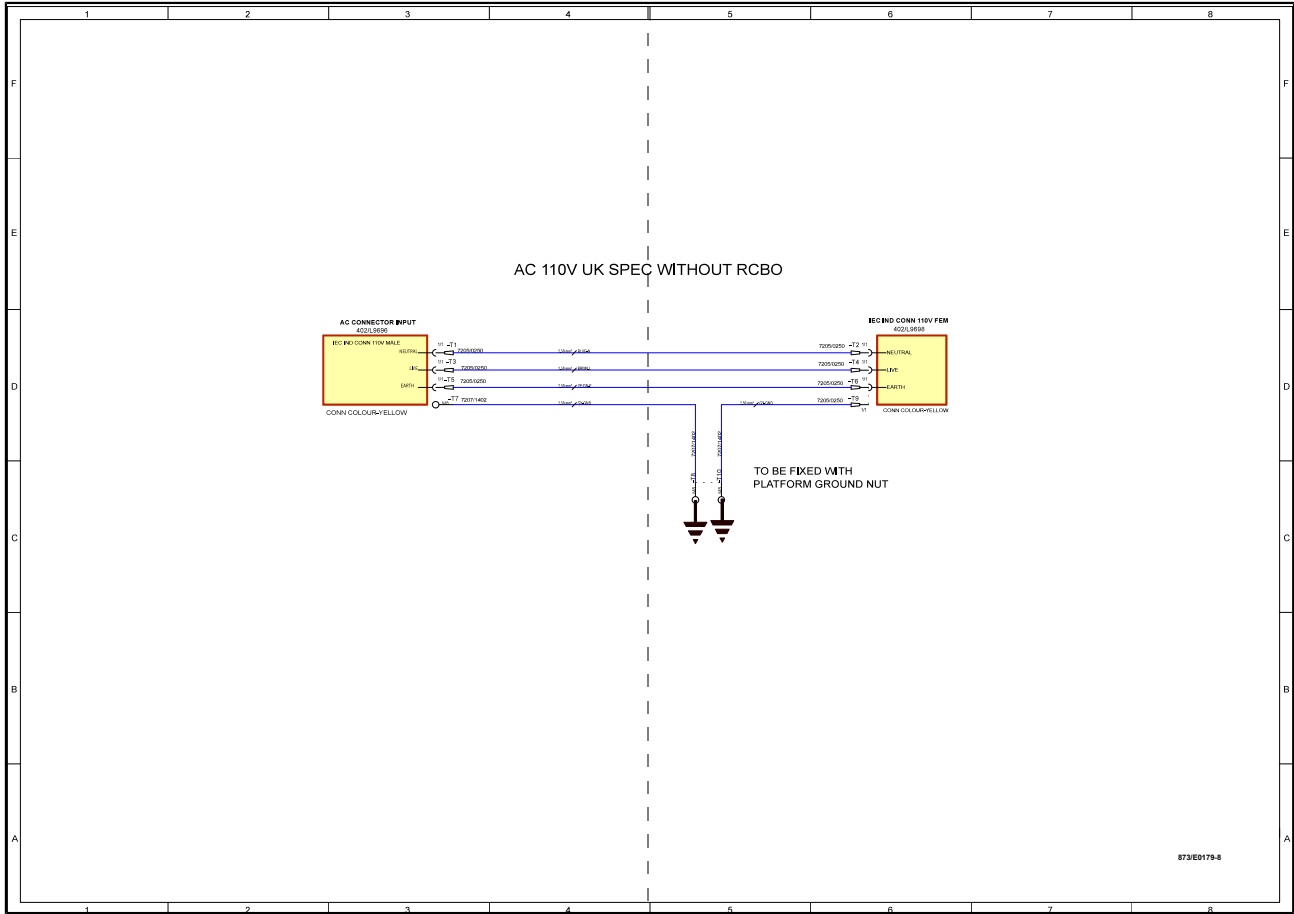
00 - Electrical System

50 - Schematic Circuit

---

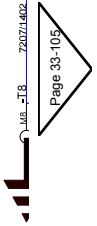
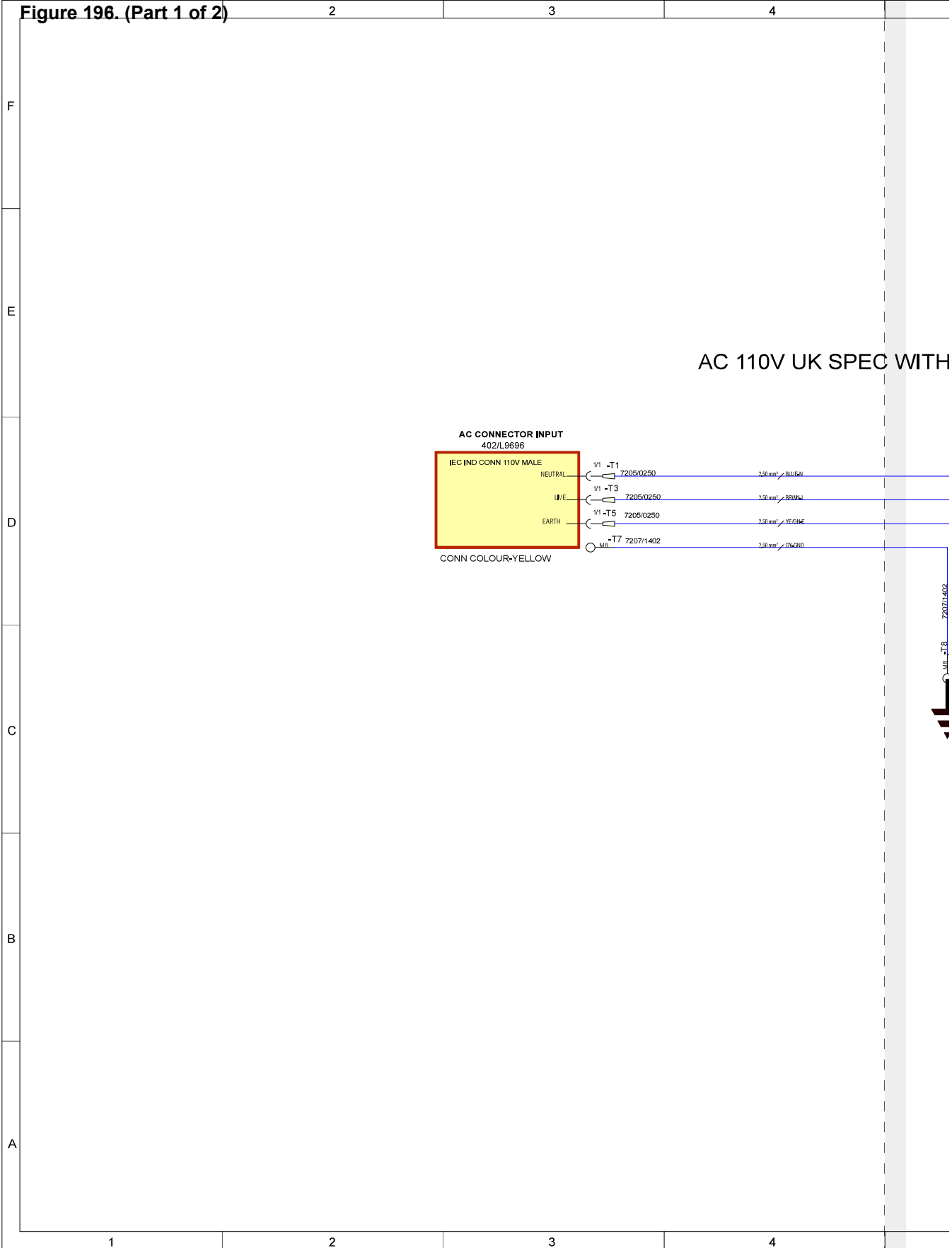
JCB © CONNOR STANMORE - 13/03/2026 07:57.

### Figure 196. 873/E0179 Issue 8 (Sheet 9 of 15) - Power to Platform UK W/O RCBO



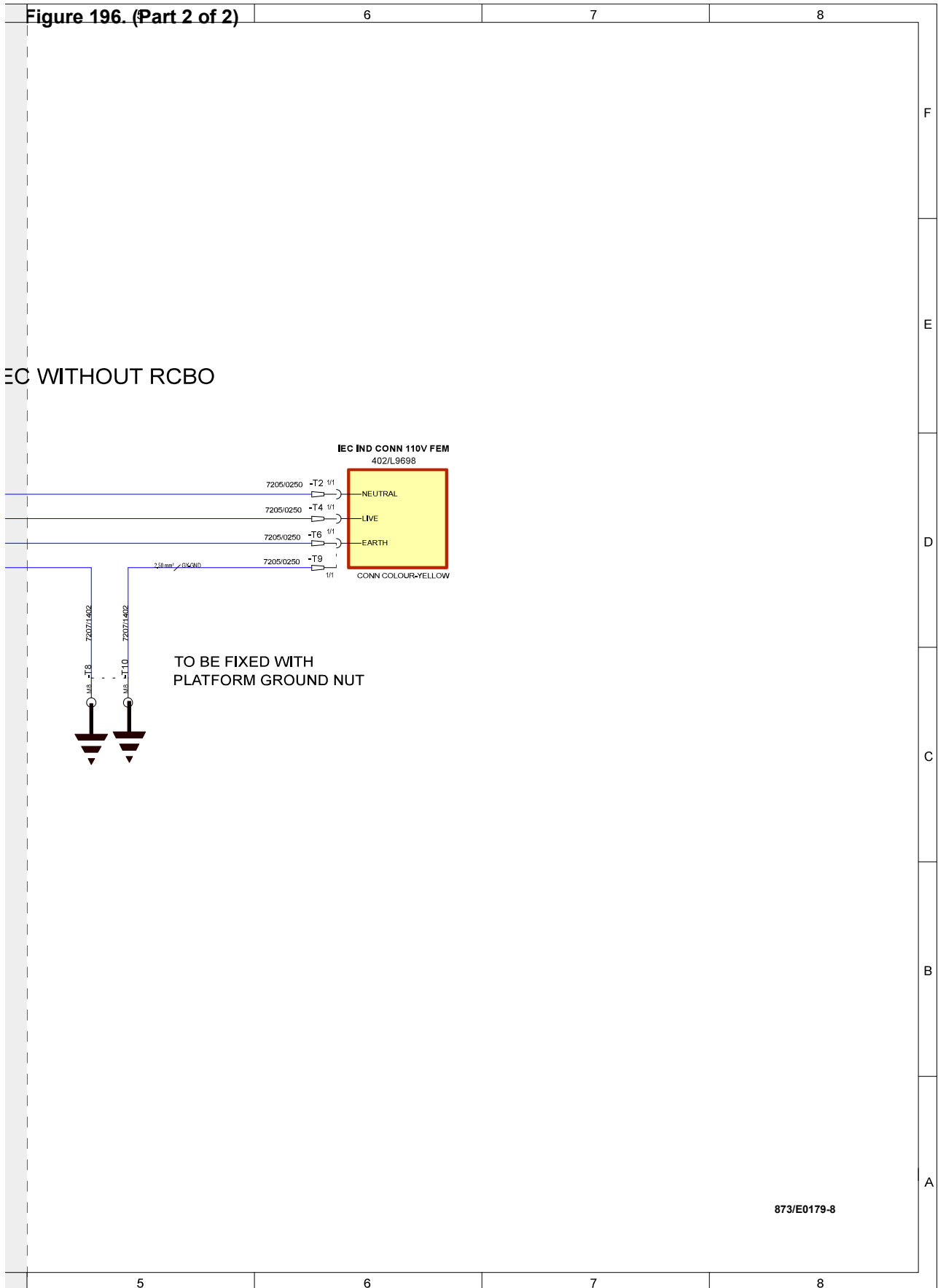
JCB © CONNOR STANMORE - 13/03/2026 07:57.

Figure 196. (Part 1 of 2)



JCB © CONNOR STANMORE - 13/03/2026 07:57.

**Figure 196. (Part 2 of 2)**



Page 33-104

JCB © CONNOR STANMORE - 13/03/2026 07:57.



## 33 - Electrical System

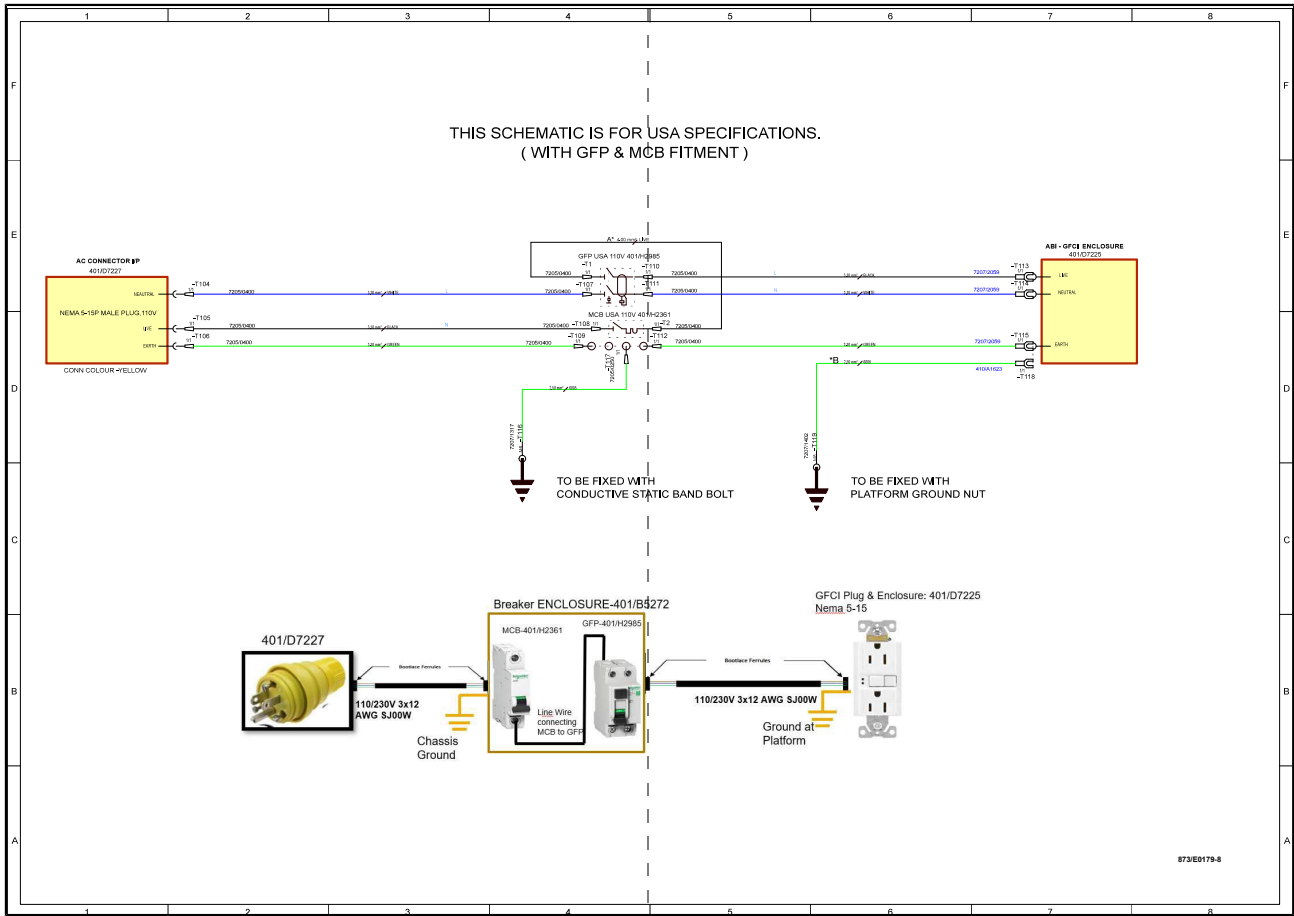
00 - Electrical System

50 - Schematic Circuit

---

JCB © CONNOR STANMORE - 13/03/2026 07:57.

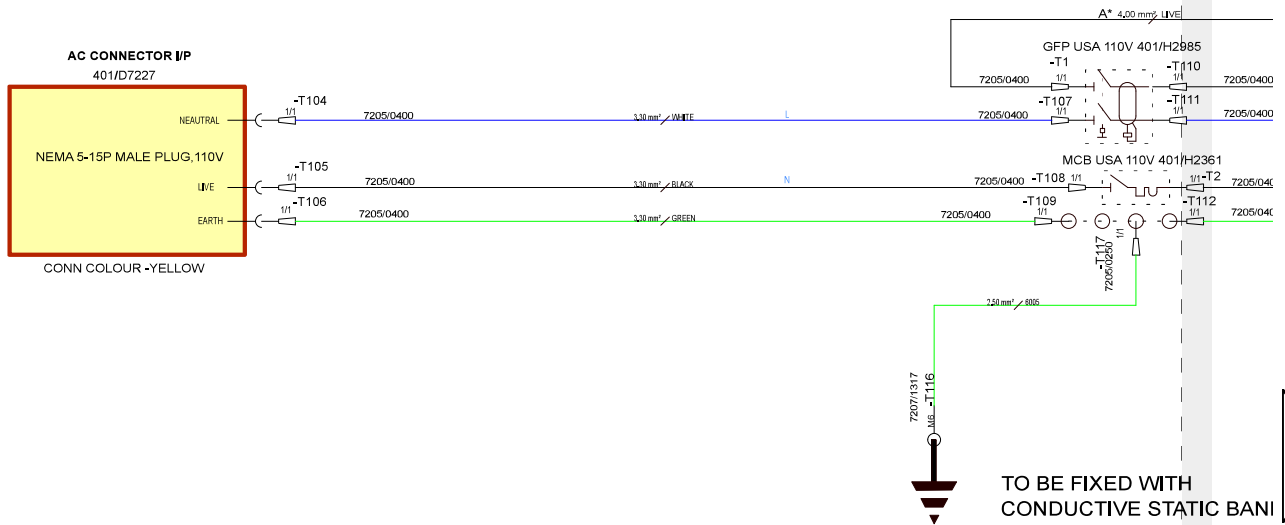
Figure 197. 873/E0179 Issue 8 (Sheet 10 of 15) - Power Cable with GFP and MCB



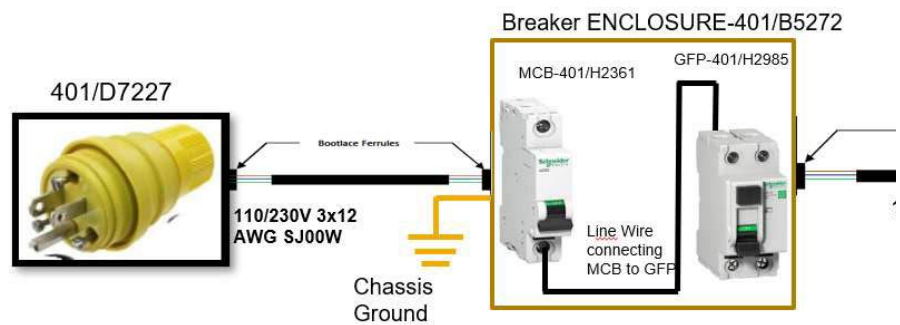
JCB © CONNOR STANMORE - 13/03/2026 07:57.

Figure 197. (Part 1 of 2)

THIS SCHEMATIC IS FOR USA SI  
( WITH GFP & MCB FIT)



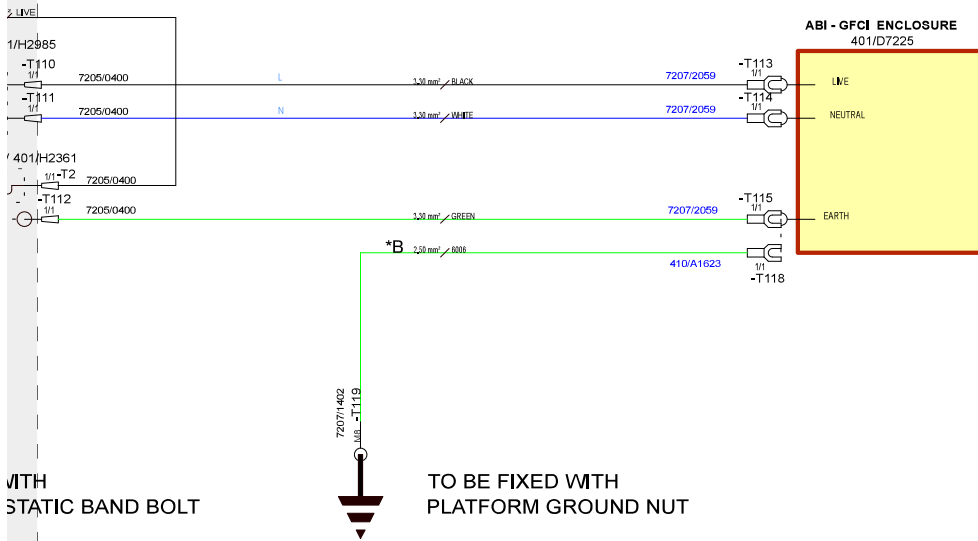
Page 33-109



JCB © CONNOR STANMORE - 13/03/2026 07:57.

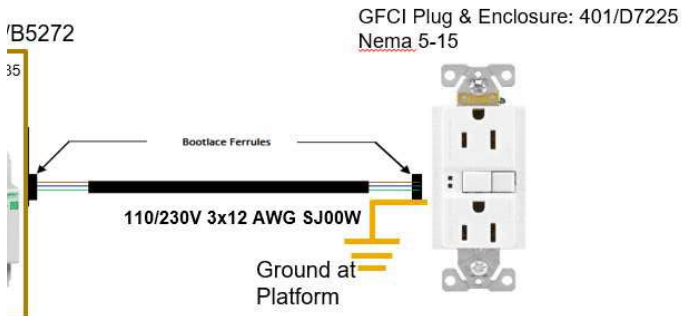
Figure 197. (Part 2 of 2)

R USA SPECIFICATIONS.  
(JCB FITMENT)



WITH  
STATIC BAND BOLT

TO BE FIXED WITH  
PLATFORM GROUND NUT



873/E0179-8

JCB © CONNOR STANMORE - 13/03/2026 07:57.



## 33 - Electrical System

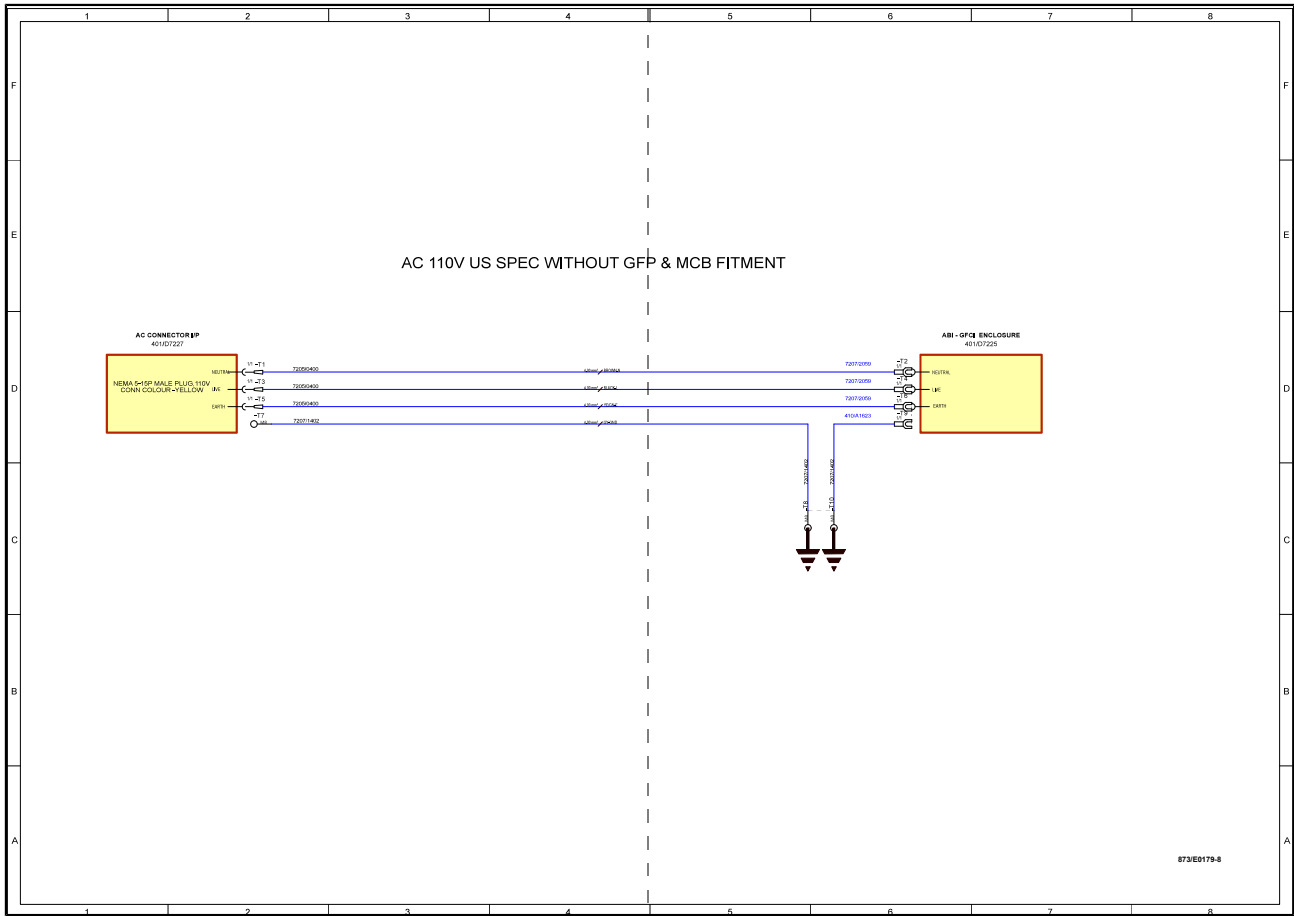
00 - Electrical System

50 - Schematic Circuit

---

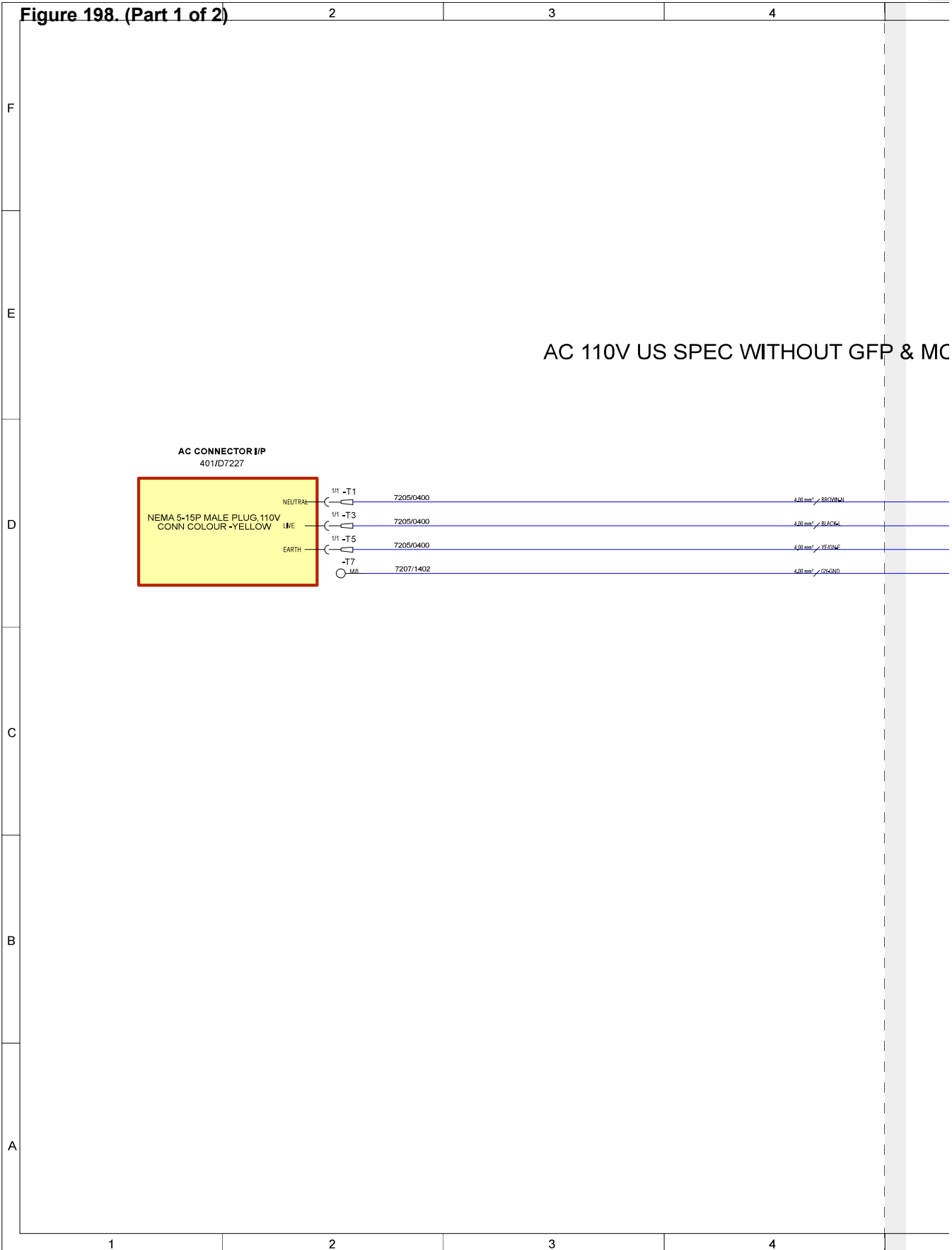
JCB © CONNOR STANMORE - 13/03/2026 07:57.

Figure 198. 873/E0179 Issue 8 (Sheet 11 of 15)  
- Power to Platform US W/O GFP and MCB



JCB © CONNOR STANMORE - 13/03/2026 07:57.

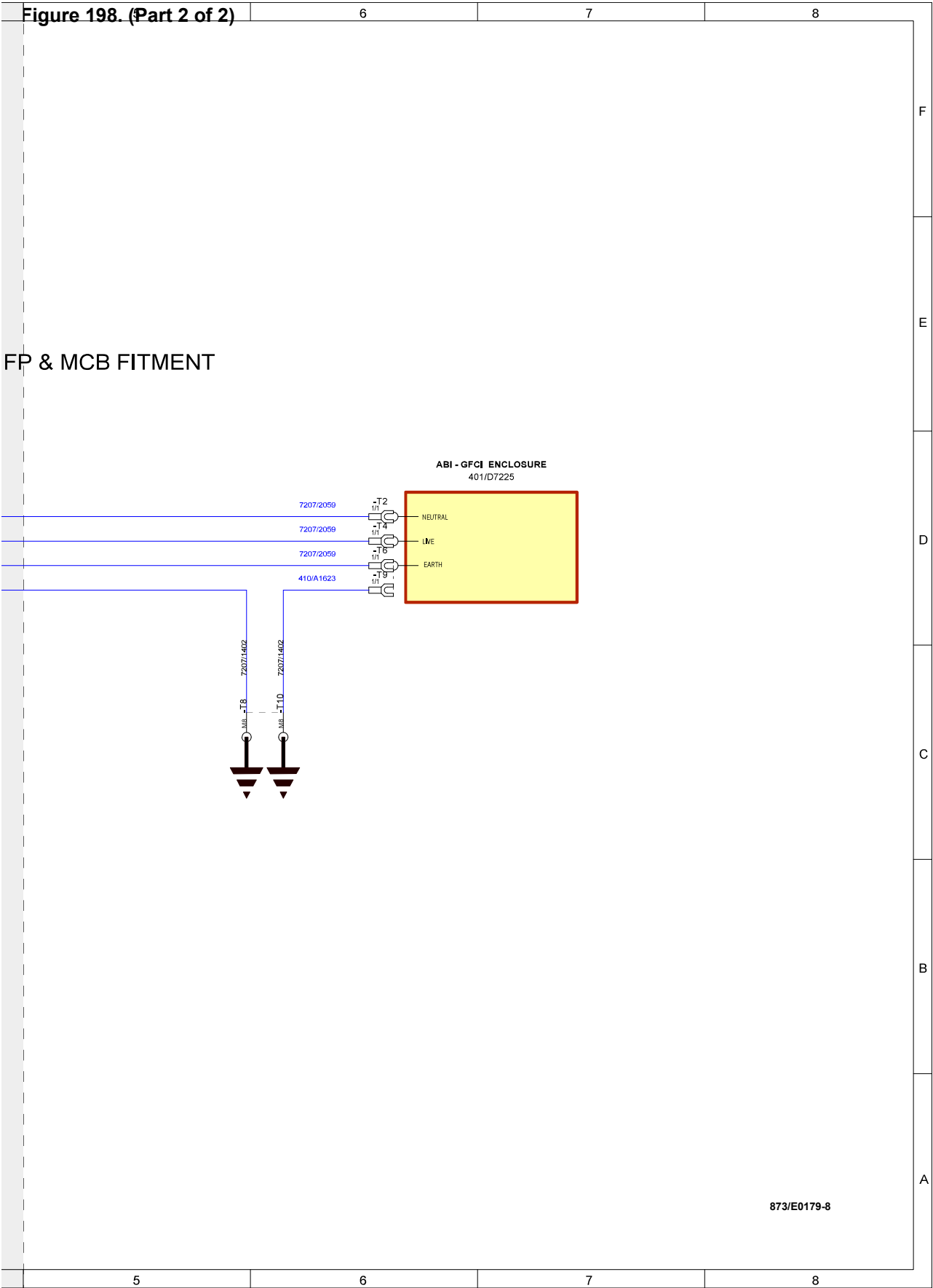
Figure 198. (Part 1 of 2)



Page 33-113

JCB © CONNOR STANMORE - 13/03/2026 07:57.

Figure 198. (Part 2 of 2)



Page 33-112

JCB © CONNOR STANMORE - 13/03/2026 07:57.



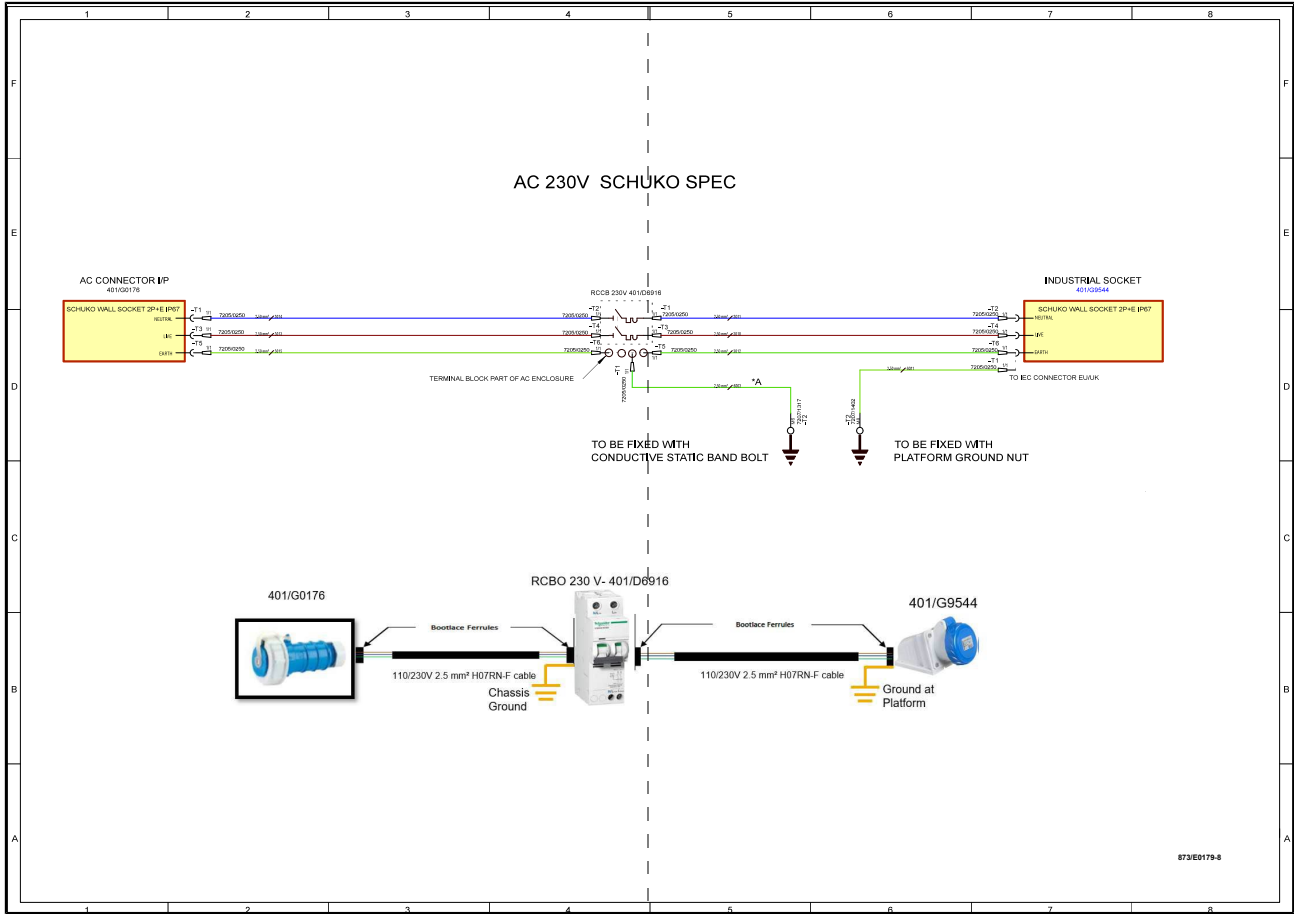
## 33 - Electrical System

00 - Electrical System

50 - Schematic Circuit

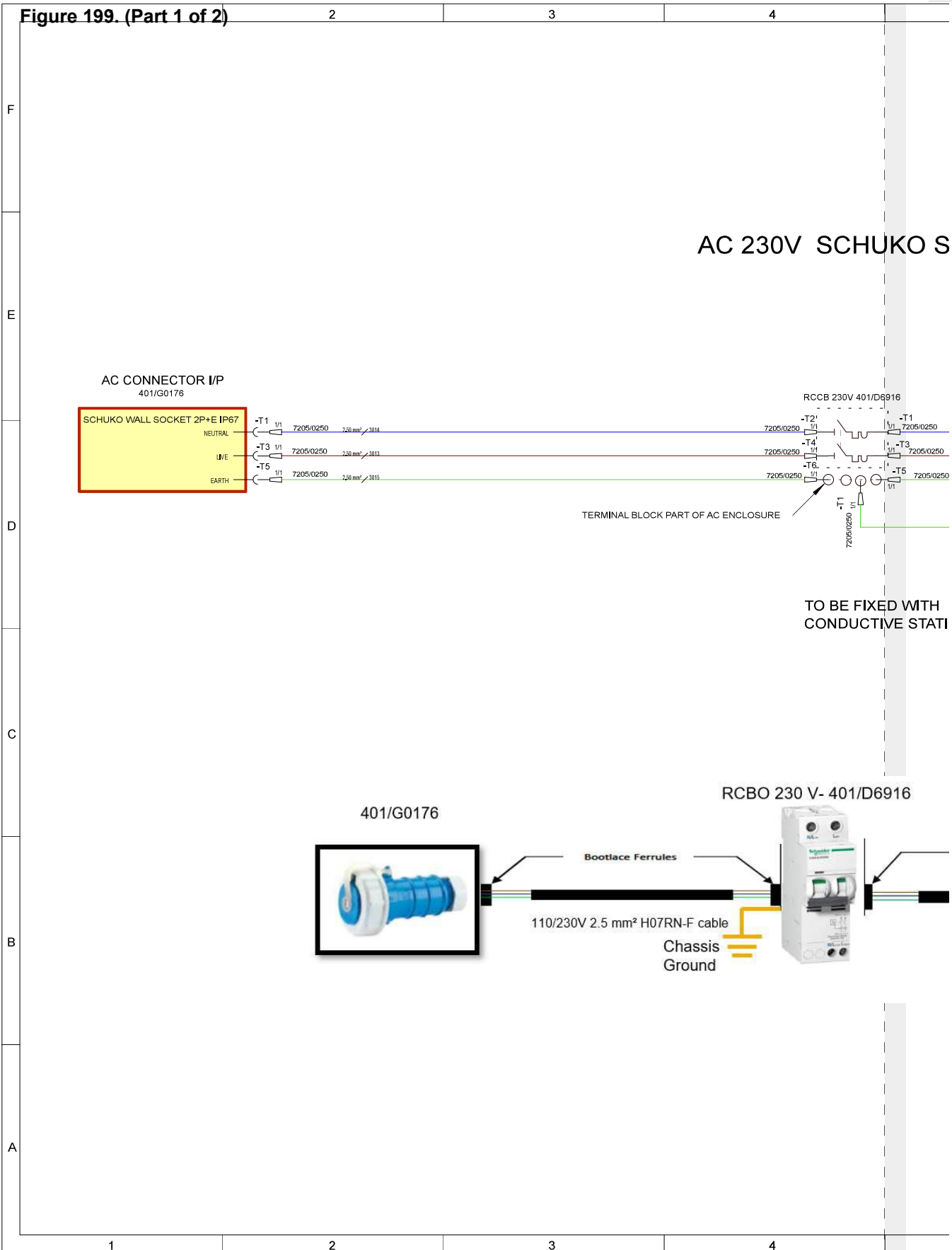
---

JCB © CONNOR STANMORE - 13/03/2026 07:57.



JCB © CONNOR STANMORE - 13/03/2026 07:57.

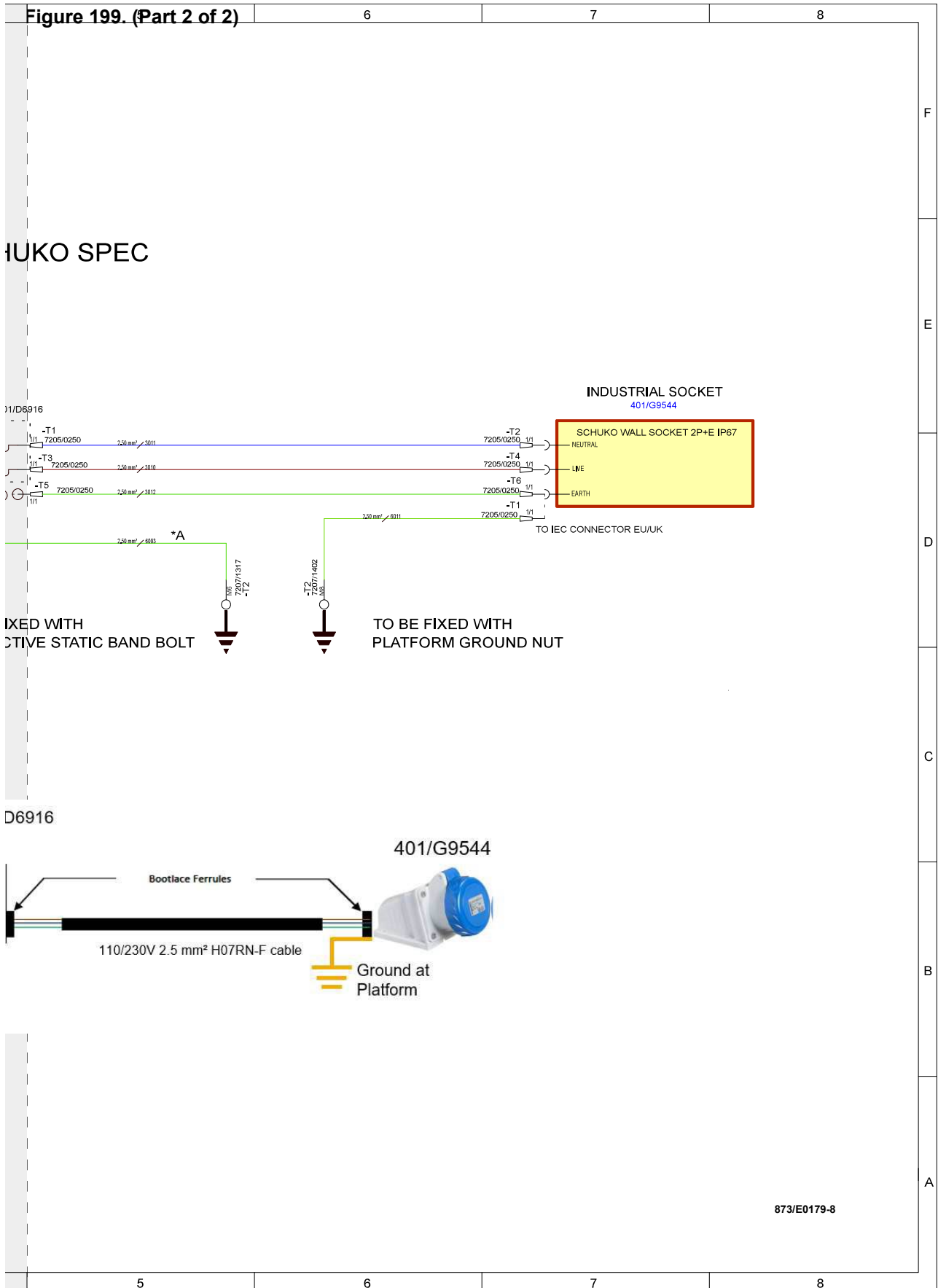
Figure 199. (Part 1 of 2)



Page 33-117

JCB © CONNOR STANMORE - 13/03/2026 07:57.

Figure 199. (Part 2 of 2)



JCB © CONNOR STANMORE - 13/03/2026 07:57.



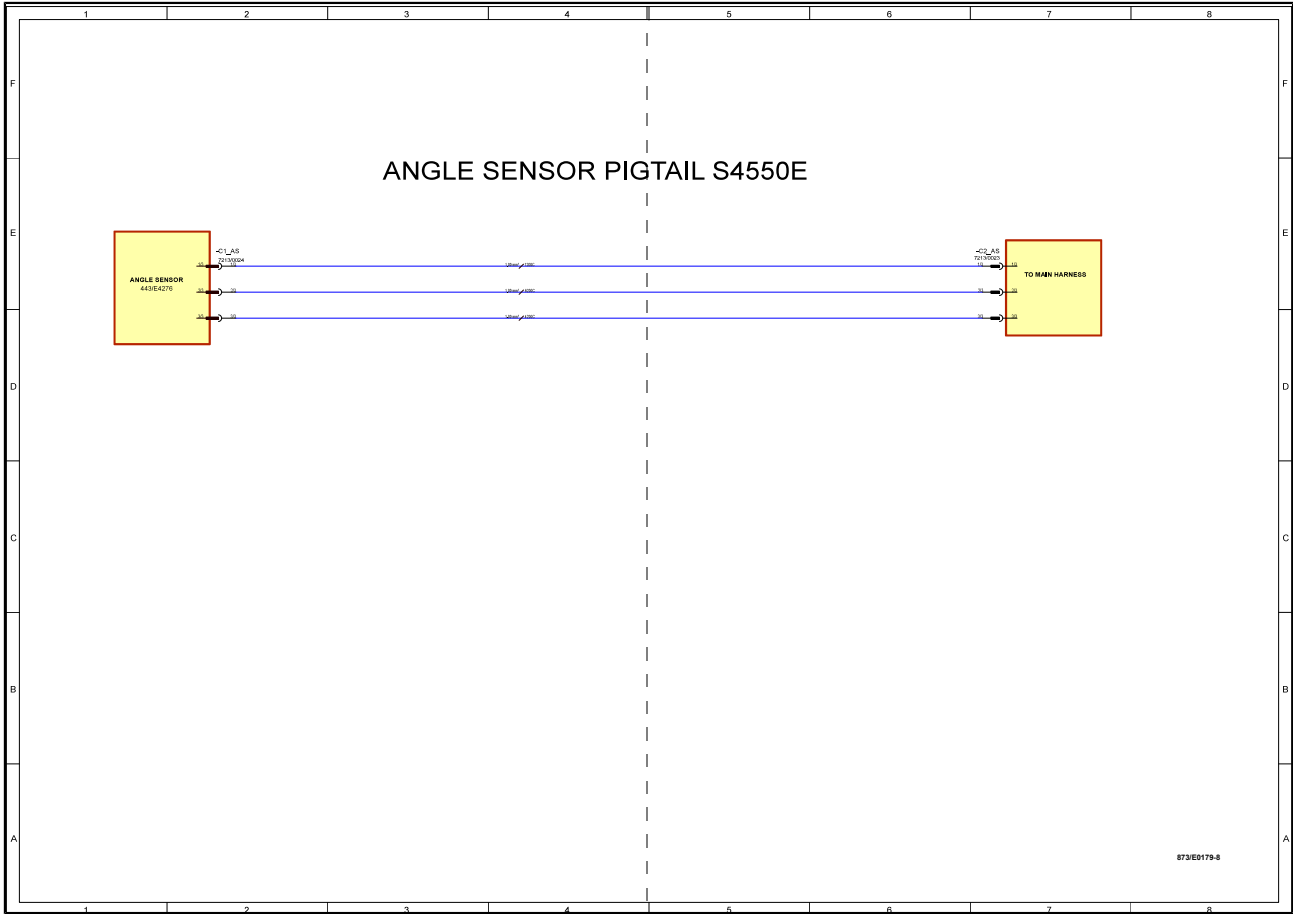
## 33 - Electrical System

00 - Electrical System

50 - Schematic Circuit

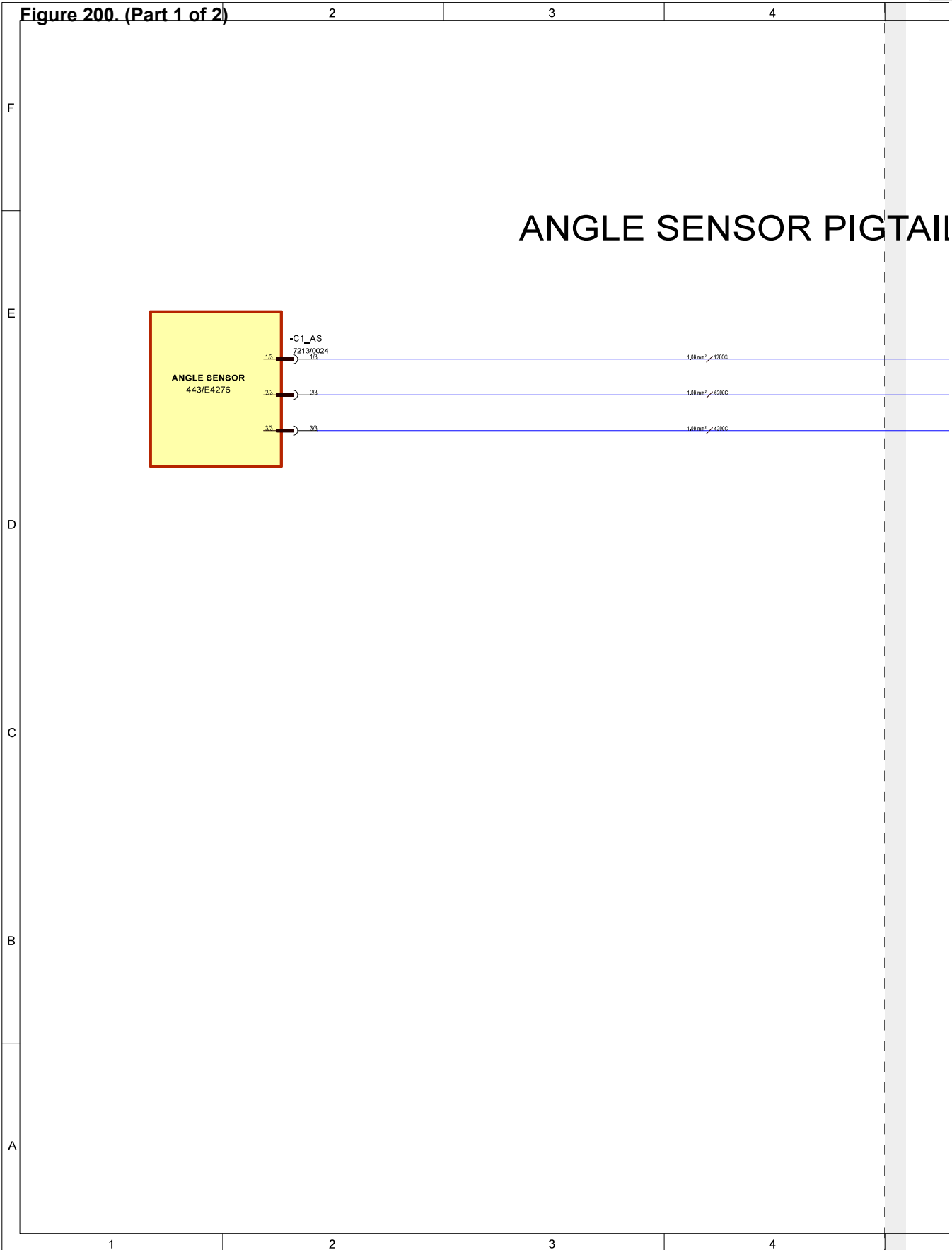
---

JCB © CONNOR STANMORE - 13/03/2026 07:57.



JCB © CONNOR STANMORE - 13/03/2026 07:57.

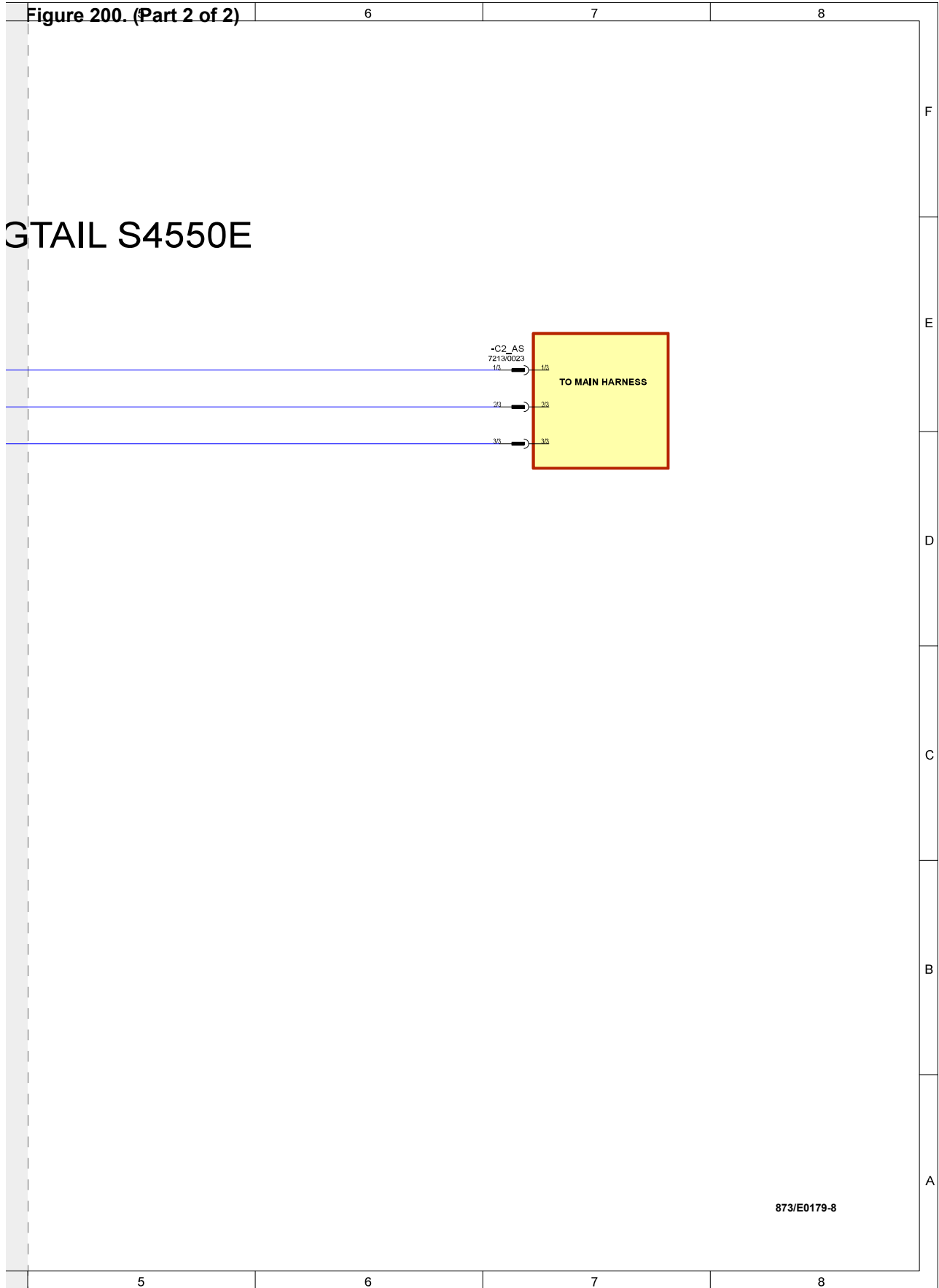
Figure 200. (Part 1 of 2)



JCB © CONNOR STANMORE - 13/03/2026 07:57.



Figure 200. (Part 2 of 2)



Page 33-120

JCB © CONNOR STANMORE - 13/03/2026 07:57.



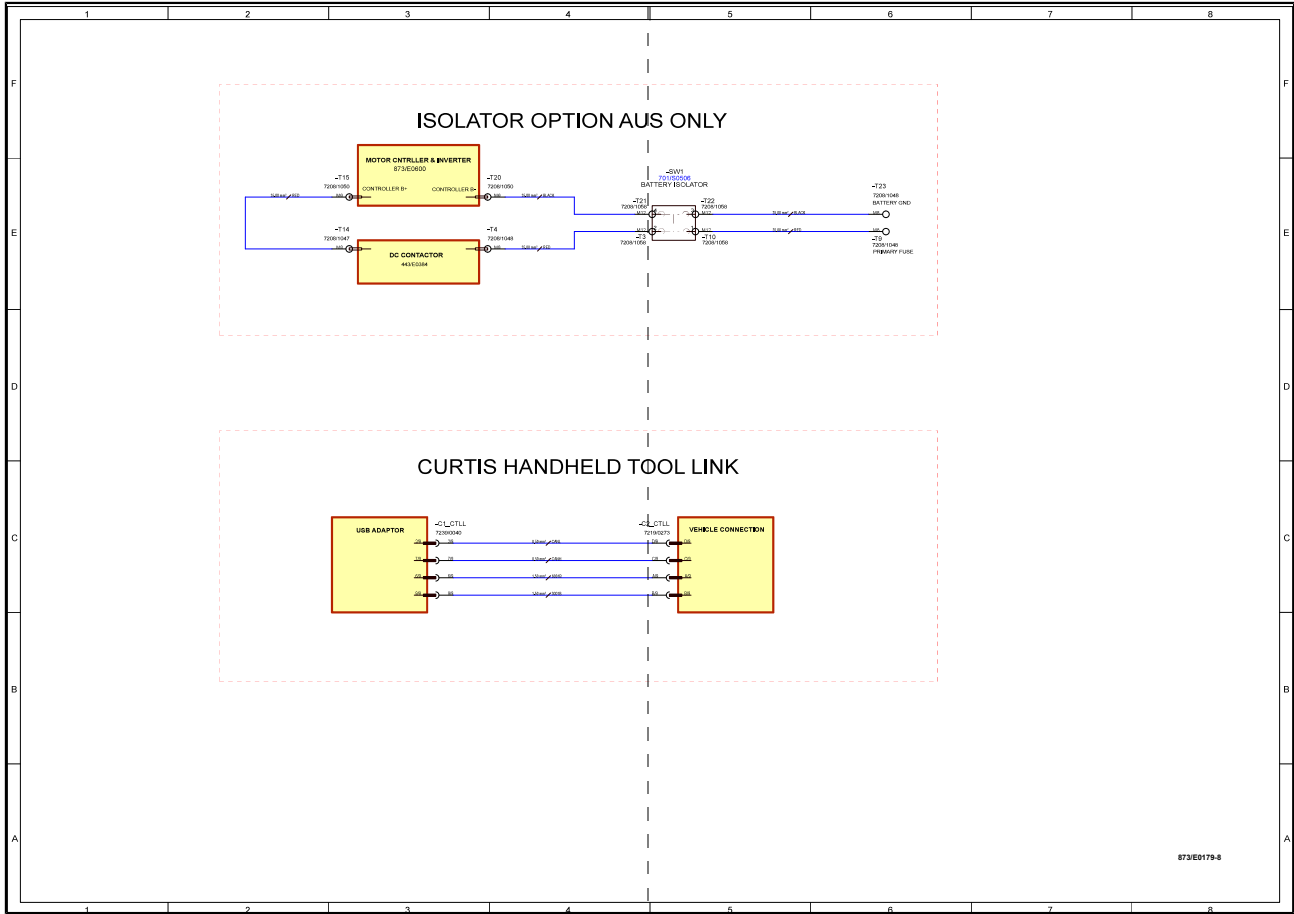
## 33 - Electrical System

00 - Electrical System

50 - Schematic Circuit

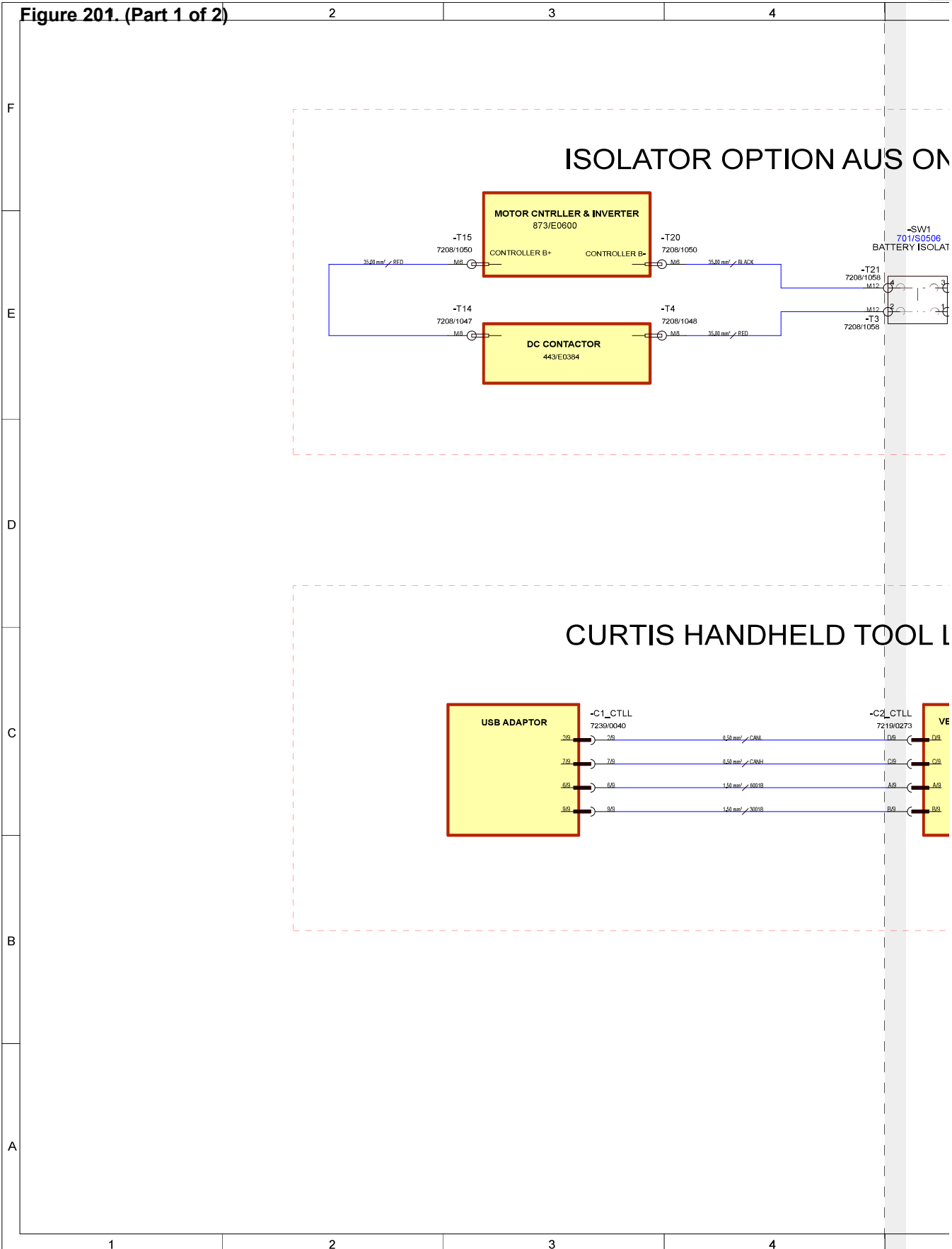
---

JCB © CONNOR STANMORE - 13/03/2026 07:57.



JCB © CONNOR STANMORE - 13/03/2026 07:57.

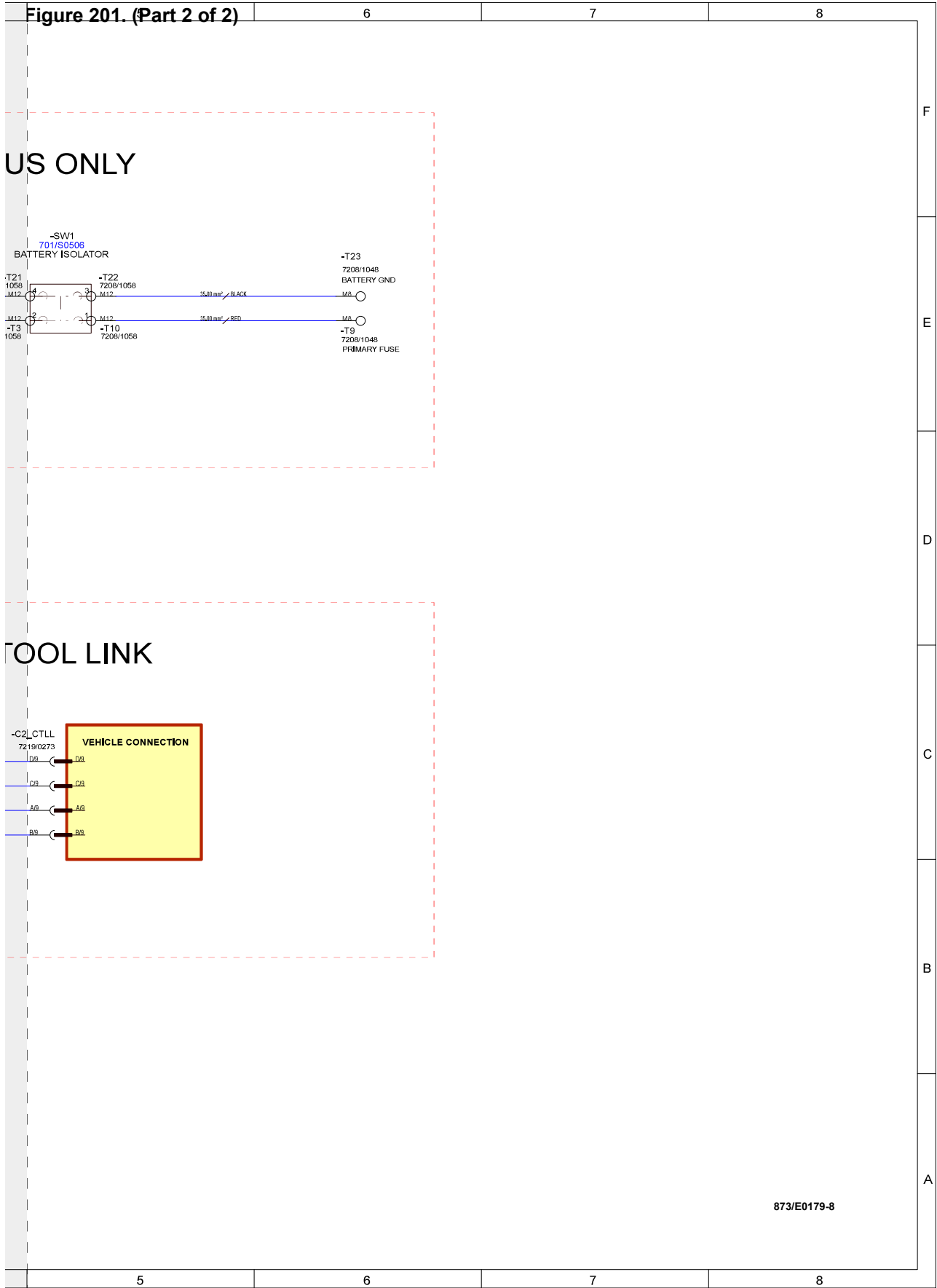
Figure 201. (Part 1 of 2)



Page 33-125

JCB © CONNOR STANMORE - 13/03/2026 07:57.

**Figure 201. (Part 2 of 2)**



JCB © CONNOR STANMORE - 13/03/2026 07:57.



## 95 - Equipotential Bonding

Introduction ..... 33-126  
Check (Condition) ..... 33-127  
Electrical Safety Testing ..... 33-127

## Introduction

Electrical bonding connects together exposed metallic parts of the machine which are not intended to carry electricity. It protects persons who may touch two separate metallic parts from electric shock in the case of an electrical fault. Joining the metal parts together eliminates any voltage potential.

JCB © CONNOR STANMORE - 13/03/2026 07:57.

## Check (Condition)

If any of the equipotential bonding connections are disturbed during maintenance or repair check their condition afterwards. Then perform a equipotential bonding resistance test.

1. Make the machine safe.
2. Check the yellow/green and braided equipotential bond cables are firmly attached to the machine, replace if damaged or corroded.

## Electrical Safety Testing

1. Make the machine safe.
2. Use a multimeter to test for resistance between the chassis ground and the earth contact (PE pole) in the onboard charger plug. Perform the test at multiple chassis positions. If the resistance is more than 0.2 ohms stop using the machine immediately and investigate the fault.

## 03 - Battery

### 00 - General

Introduction .....	33-128
Health and Safety .....	33-129
Component Identification .....	33-130
Disconnect and Connect .....	33-131
Drain and Fill .....	33-133
Clean .....	33-134
Check (Condition) .....	33-135
Check (Level) .....	33-137
Remove and Install .....	33-140
Store and Recommission .....	33-140

### Introduction

The machine has four separate 6V batteries connected in series to give out 24V.

The batteries installed on these machines are deep-cycle flooded batteries (wet). In the flooded type batteries, the electrolyte is a solution of sulphuric acid and water than can spill out if the battery is tipped over.

The batteries are used to drive the electric motor and the control unit which drives the hydraulic pump to provide the required hydraulic power for machine operation.

The batteries are charged with a battery charger installed on the machine through an external power supply.

The battery technical data is given in the Electrical System, Technical Data.

[Refer to: Technical Data \(PIL 33-00-00\).](#)

#### Charging

- It is recommended to charge batteries to full, i.e. 100%, as displayed in battery charger display. Opportunity charging/partial charging may reduce the life of battery and result in lower capacity over time.
- In case of opportunity charging/partial charging, battery charge percentage on base display & PCU may show 100% initially. It will stabilize to actual percentage after few minutes of operation.

### Battery Management System

Machines equipped with lead acid batteries have a battery management system which will protect the batteries from damage due to adverse operating conditions. In the event of batteries being discharged to the safe limit the system will disconnect the battery output until the batteries are recharged. In this case, no machine movement will be possible until they are recharged. It is important that the battery charge level is checked on display during operation and the machine is put on to charge when the level reached two bars.

The electric motor will start to cut out when the voltage drops to a level requiring recharge. If the motor cuts out then when safe to do so lower the platform immediately and move the machine to a charging point.

Machine will go into limp mode at 10% of battery charge ( as seen in base display & PCU). In limp mode machine operations will be reduced to 50% speed. At 5% of battery charge all machine operations will stop to protect the batteries. When nominal battery voltage reaches 16V16V, controllers starts to cutback.

## Health and Safety

**▲ DANGER** Batteries give off an explosive gas. Do not smoke when handling or working on the battery. Keep the battery away from sparks and flames.

Battery electrolyte contains sulphuric acid. It can burn you if it touches your skin or eyes. Wear goggles. Handle the battery carefully to prevent spillage. Keep metallic items (watches, rings, zips etc) away from the battery terminals. Such items could short the terminals and burn you.

Set all switches to off before disconnecting and connecting the battery. When disconnecting the battery, take off the earth (-) lead first.

When reconnecting, attach the positive (+) lead first.

**WARNING** Battery electrolyte is toxic and corrosive. Do not breathe the gases given off by the battery. Keep the electrolyte away from your clothes, skin, mouth and eyes. Wear safety glasses.

**WARNING** Do not top the battery up with acid. The electrolyte could boil out and burn you.

**CAUTION** Understand the electrical circuit before connecting or disconnecting an electrical component. A wrong connection can cause injury and/or damage.

**Notice:** Do not disconnect the battery while the platform is in operation, otherwise the electrical circuits may be damaged.

**DANGER** If you try to charge a frozen battery, the battery could explode. Do not use a battery if its electrolyte is frozen. To prevent the battery electrolyte from freezing, keep the battery at full charge.

**CAUTION** Damaged or spent batteries and any residue from fires or spillage must be put in a suitable closed receptacle and must be disposed of in accordance with local environmental waste regulations.

**Notice:** Before carrying out arc welding on the machine, disconnect the battery to protect the circuits and components. The battery must still be disconnected even if a battery isolator is installed.

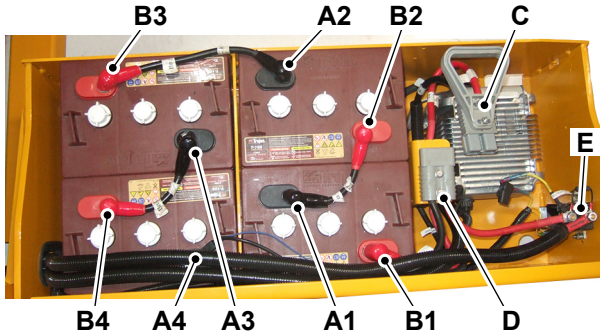
**WARNING** The batteries remain live even when the isolator key is removed.

**WARNING** You could get killed or injured if you touch the Battery positive and Battery negative terminals of the motor controller. The controller is installed with energy storing devices (capacitors). You must discharge the controller before you remove or install.

## Component Identification

Make a note that the illustration shows a typical 6V battery layout for reference. The 12V battery layout will look different.

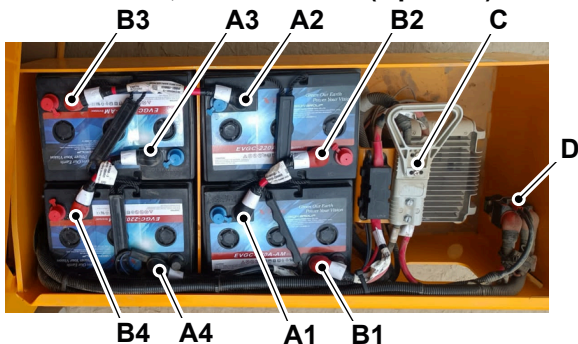
**Figure 202. Trojan Battery**



- A1 Negative cable - Battery 1
- A2 Negative cable - Battery 2
- A3 Negative cable - Battery 3
- A4 Negative cable - Battery 4
- B1 Positive cable - Battery 1
- B2 Positive cable - Battery 2
- B3 Positive cable - Battery 3
- B4 Positive cable - Battery 4
- C Battery quick disconnect handle
- D Battery quick disconnect coupling
- E DC (Direct Current) contactor

Make a note that the illustration shows a typical 6V battery layout for reference.

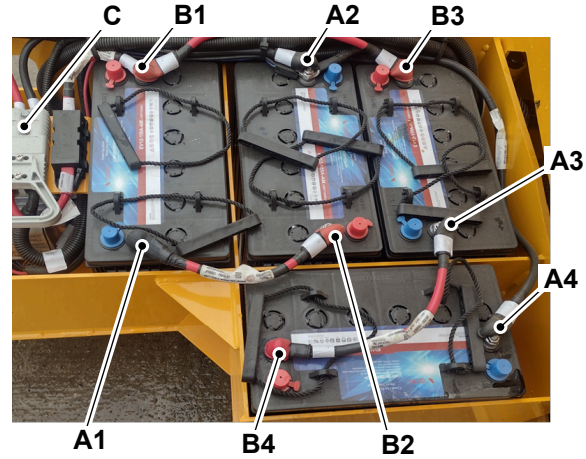
**Figure 203. AGM Battery (6V) - For S1932E EDRV, S2632E EDRV, S2646E EDRV, S3246E EDRV (Optional)**



- A1 Negative cable - Battery 1
- A2 Negative cable - Battery 2
- A3 Negative cable - Battery 3
- A4 Negative cable - Battery 4
- B1 Positive cable - Battery 1
- B2 Positive cable - Battery 2
- B3 Positive cable - Battery 3
- B4 Positive cable - Battery 4
- C Battery quick disconnect handle
- D DC contactor

Make a note that the illustration shows a typical 12V battery layout for reference.

**Figure 204. AGM Battery (12V) - For S4046E EDRV, S4550E EDRV (Optional)**



- A1 Negative cable - Battery 1
- A2 Negative cable - Battery 2
- A3 Negative cable - Battery 3
- A4 Negative cable - Battery 4
- B1 Positive cable - Battery 1
- B2 Positive cable - Battery 2
- B3 Positive cable - Battery 3
- B4 Positive cable - Battery 4
- C Battery quick disconnect handle

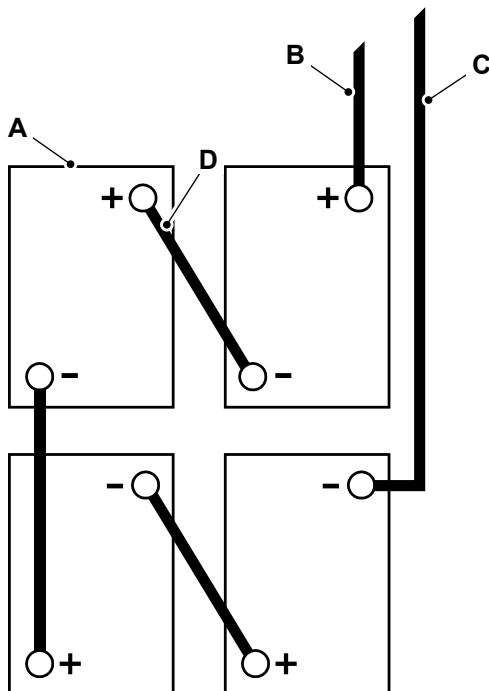
## Disconnect and Connect

Make sure that you connect the batteries correctly for your machine.

### Disconnect

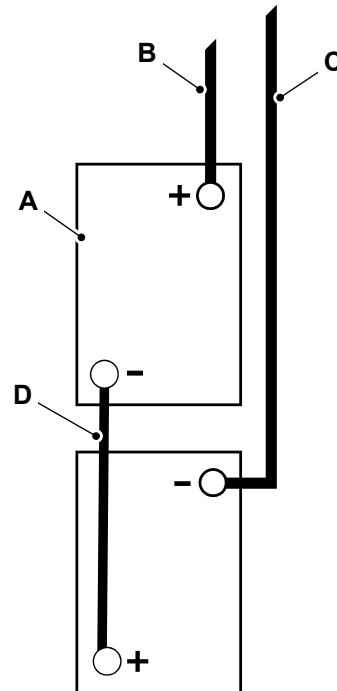
1. Make the machine safe.  
Refer to: PIL 01-03-27.
2. Open the battery compartment door.  
Refer to: Open and Close (PIL 06-06-03).
3. Disconnect the battery quick disconnect handle.  
Refer to: Disconnect and Connect (PIL 33-05-00).
4. Disconnect the battery negative lead first.
5. Disconnect the battery positive lead and store away from the batteries.
6. Disconnect and remove the battery link leads.

**Figure 205. Typical Battery Series Connection (Four batteries)**

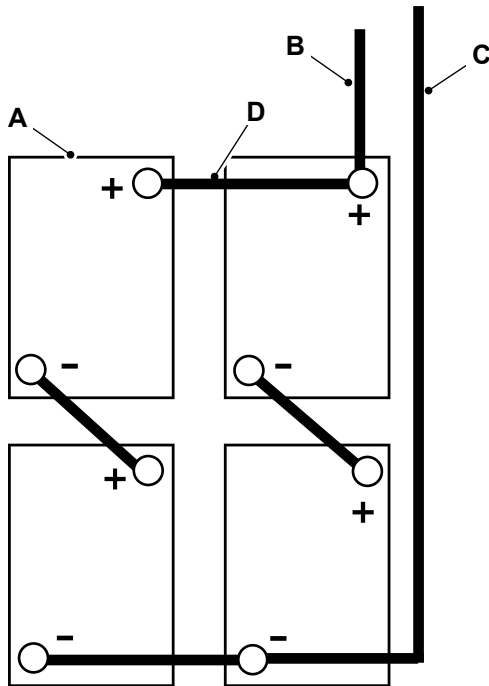


- A Battery (x4)
- B Battery negative lead
- C Battery positive lead
- D Battery link leads (x3)

**Figure 206. Typical Battery Series Connection (Two batteries)**



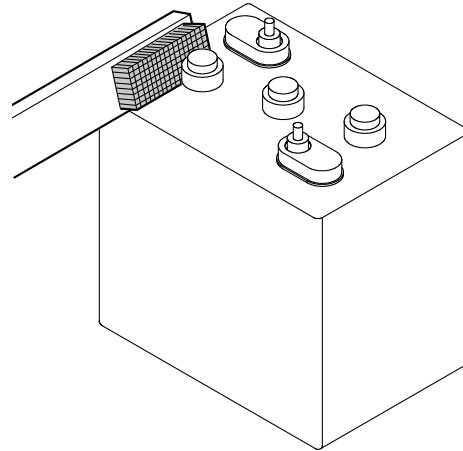
- A Battery (x2)
- B Battery negative lead
- C Battery positive lead
- D Battery link leads

**Figure 207. Typical Battery Series-Parallel Connection**


- A Battery (x4)
- B Battery negative lead
- C Battery positive lead
- D Battery link leads (x4)

**Connect**

1. Check the battery as follows:
  - 1.1. If any terminals are dirty, clean them.
  - 1.2. If the terminal is corroded and has white powder, wash the terminal with hot water. Make sure the water does not enter the battery cells.
  - 1.3. If considerable corrosion is found, then clean with a wire brush or abrasive paper. Make sure you use eye and hand protection. [Refer to Figure 208.](#)

**Figure 208.**


- 1.4. After cleaning, apply a thin coat of petroleum jelly to the terminals.
2. If necessary, fill the distilled water.
3. Connect the leads.
  - 3.1. First connect the link leads.
  - 3.2. Connect the positive battery lead.
  - 3.3. Finally connect the negative battery lead.
4. Tighten the battery terminal nuts to the correct torque value.
5. Connect the battery quick disconnect handle.
 

[Refer to: Disconnect and Connect \(PIL 33-05-00\).](#)
6. Close the battery compartment door.
 

[Refer to: Open and Close \(PIL 06-06-03\).](#)

**Table 74. Torque Values**

Item	Description	Nm
E	Battery terminal nut	35 ± 3

## Drain and Fill

This section is only applicable for the flooded batteries.

Important: It is not recommended to drain batteries installed on these machines.

Make a note of the following.

- Only flooded type batteries need water.
- You must add distilled water at the right time and in the right amount. If you do not do this, it will affect the performance and life of the battery.
- You must add distilled water only after the battery is fully charged.
- There should be enough water to cover the plates, before you charge the battery. If the battery is discharged (partially or fully), the water level should also be above the plates.
- It is recommended that the batteries must be checked daily.
- Do not allow the plates to get exposed to air. This will damage (corrode) the plates.
- Do not fill the water level in the filling well to the cap. This will cause the battery to overflow acid.
- Do not use water with a high mineral content. Use distilled or deionized water only.

## Adding Liquid (Only for Flooded Batteries)

Obey all battery health and safety information.  
[Refer to: Health and Safety \(PIL 33-03-00\).](#)

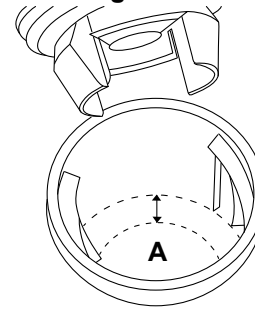
1. Make the machine safe.  
[Refer to: Introduction \(PIL 01-03-27\).](#)
2. Open the battery compartment door.  
[Refer to: PIL 06-06-03.](#)
3. Disconnect the battery quick disconnect handle.  
[Refer to: Disconnect and Connect \(PIL 33-05-00\).](#)
4. Remove the vent caps.
5. Check the electrolyte level.
  - 5.1. The minimum level is at the top of the plates.
  - 5.2. If necessary, add just enough distilled water to cover the plates at this time.
6. Install the vent caps.
7. Top up the batteries before you put them for charging.
8. Remove the vent caps.

9. Add water until the electrolyte level is below the bottom of the fill well by the specified value.

Distance: 3.175mm

- 9.1. If necessary, use a piece of rubber as a dipstick to determine this level.

**Figure 209.**



**A** Electrolyte level (3.175mm)

10. Clean the vent caps.
11. Install the vent caps.

## Clean

1. Make the machine safe.  
[Refer to: PIL 01-03-27.](#)
2. Open the battery compartment door.  
[Refer to: Open and Close \(PIL 06-06-03\).](#)
3. If installed, make sure that all vent caps are tightly installed.
4. Make sure that you do not touch both battery terminals at the same time.
5. Clean the battery top with a cloth or brush. Use a solution of baking soda and water as required for wiping only.
6. Do not allow any cleaning solution or other foreign matter to get inside the battery.
7. Wipe the battery with damp cloth.
8. Dry the battery with a clean cloth.
9. Disconnect the battery terminals.
10. Clean the battery terminals.
11. Clean the inside of the cable clamps with a post and clamp cleaner.
12. Clean the terminal to have a bright metallic shine.
13. Connect the clamps to the terminals.
14. Apply a thin layer of an anti-corrosive spray or petroleum gel to the battery terminals.
15. Keep the area around batteries clean and dry.
16. Close the battery compartment door.  
[Refer to: Open and Close \(PIL 06-06-03\).](#)

## Check (Condition)

### Special Tools

Description	Part No.	Qty.
Meter (hydrometer)	333/H5664	1

### Visual Inspection

1. Make the machine safe.  
[Refer to: Introduction \(PIL 01-03-27\).](#)
2. Open the battery compartment door.  
[Refer to: Open and Close \(PIL 06-06-03\).](#)
3. Disconnect the battery quick disconnect handle.  
[Refer to: Disconnect and Connect \(PIL 33-05-00\).](#)
4. Check the condition of the outside appearance of the battery.
  - 4.1. Look for cracks in the battery shell and the battery cover.
  - 4.2. Make sure that the top of the battery, battery posts and connections are clean, free of dirt, fluids and corrosion.
  - 4.3. Repair or replace any damaged batteries as required.
5. Make a note that any fluids on or around the battery is an indication that electrolyte is spilling, leaching or leaking out. Replace or repair the leaking batteries as required.
6. Check the condition of all battery cables and their connections.
  - 6.1. Look closely for loose or damaged parts.
  - 6.2. Make sure that all battery cables are intact. Make a note that broken or damaged cables are extremely hazardous.
  - 6.3. Replace any cable that is damaged.
7. Tighten all the wiring connections to the correct torque values.
  - 7.1. Make sure that there is a good contact with the terminals.

### Specific Gravity Test (Only for Flooded Batteries)

1. Make the machine safe.  
[Refer to: Introduction \(PIL 01-03-27\).](#)
2. Open the battery compartment door.  
[Refer to: Open and Close \(PIL 06-06-03\).](#)

3. Disconnect the battery quick disconnect handle.  
[Refer to: Disconnect and Connect \(PIL 33-05-00\).](#)
4. Remove the battery vent caps.
5. Do not add water at this time.
6. Fill and drain the hydrometer 2 to 4 times before you pull out a sample.  
**Special Tool: Meter (hydrometer) (Qty.: 1)**
7. Make sure that there is enough sample electrolyte in the hydrometer to completely support the float.
8. Make a note of the reading on the Hydrometer. Return the electrolyte back to the cell.
9. Do the step 6 to step 8 for each cell of the battery.
10. Install the battery vent caps. Wipe off any spilled electrolyte.
11. Correct the readings to ambient temperature.  
[Refer to Table 75.](#)
12. Check the state of charge with reference to the table. [Refer to Table 75.](#)
  - 12.1. Make sure that the specific gravity reading is as specified. 1.277 +/- 0.007
13. If any specific gravity reading is low, do the following.
  - 13.1. Check and record voltage levels.
  - 13.2. Put the battery on a complete charge.  
[Refer to: Check \(Level\) \(PIL 33-03-00\).](#)
  - 13.3. Take specific gravity readings again.
14. If any specific gravity reading is low, do the battery equalizing procedure.

### Open Circuit Voltage Test

For accurate voltage readings, batteries must remain idle (no charging, no discharging) for at least 6h, preferably 24h.

1. Disconnect all loads from the batteries.
2. Measure the voltage with a DC voltmeter.
3. Check the state of charge. [Refer to Table 75.](#)
4. Charge the battery if it reads 0% to 70% charged.



Table 75. State of Charge at 20 degrees C

Percentage of Charge	Specific Gravity (Corrected) <sup>(1, 2)</sup>	Open Circuit Voltage	
		6V battery	12V battery
100	1.277	6.37V	12.73V
90	1.258	6.31V	12.62V
80	1.238	6.25V	12.5V
70	1.217	6.19V	12.37V
60	1.195	6.12V	12.27V
50	1.172	6.02V	12.1V
40	1.148	5.98V	11.89V
30	1.124	5.91V	11.81V
20	1.098	5.83V	11.66V
10	1.073	5.75V	11.51V

(1) Add 0.004 to readings for every 5.6°C (42.1°F) above charge temperature.

(2) Subtract 0.004 from readings for every 5.6°C (42.1°F) below charge temperature.

JCB © CONNOR STANMORE - 13/03/2026 07:57.

## Check (Level)

**▲ WARNING** Do not connect the charger when the batteries are not connected. Doing so could result in danger of live terminals from the charger.

Do not carry out maintenance on a machine whilst the charger is connected to an external power supply (i.e. do not work on a live machine). Cables from the charger to the batteries may remain live even if the batteries are disconnected/removed from the machine. There is a risk of serious electrical shock.

Always disconnect all external power supplies to the machine before carrying out maintenance.

Electrolyte checks must be done to check state of the battery.

To check the battery state of charge:

1. Disconnect the isolator.
2. Ensure the charger is not connected to an external power supply.
3. Measure the voltage across the battery terminals.

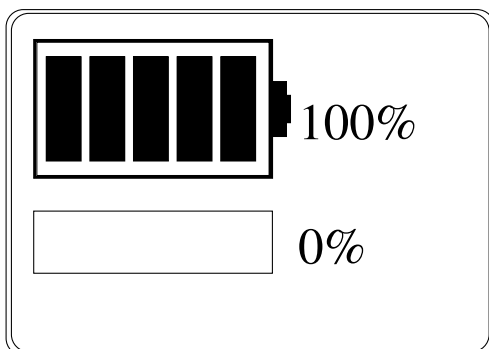
The battery state of charge can also be read from the charger display when the machine is on charge. Refer to Figure 211.

An approximate charge level of the battery is shown on the platform controller. Refer to Figure 210.

When the charge level of the batteries is about 20%, the battery must be charged. Never let the battery fully discharge before charging.

When the battery voltage is low, select tortoise speed mode and drive at slowly/half throttle to a charge location.

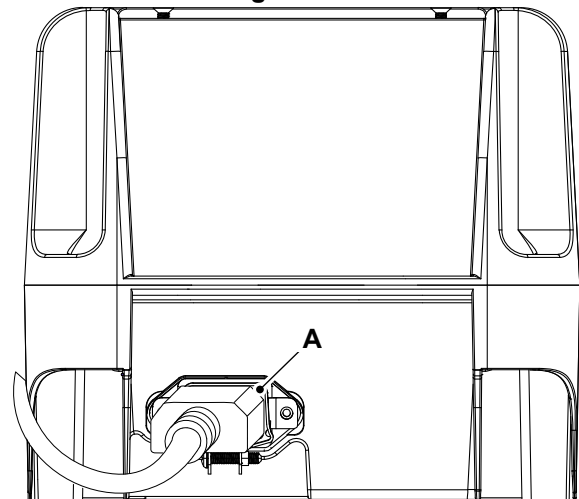
**Figure 210. Platform Control Display**



## Charge the Battery

When charging the batteries, refer to the battery charger display to view the charge status of the batteries. Refer to Figure 211.

**Figure 211.**



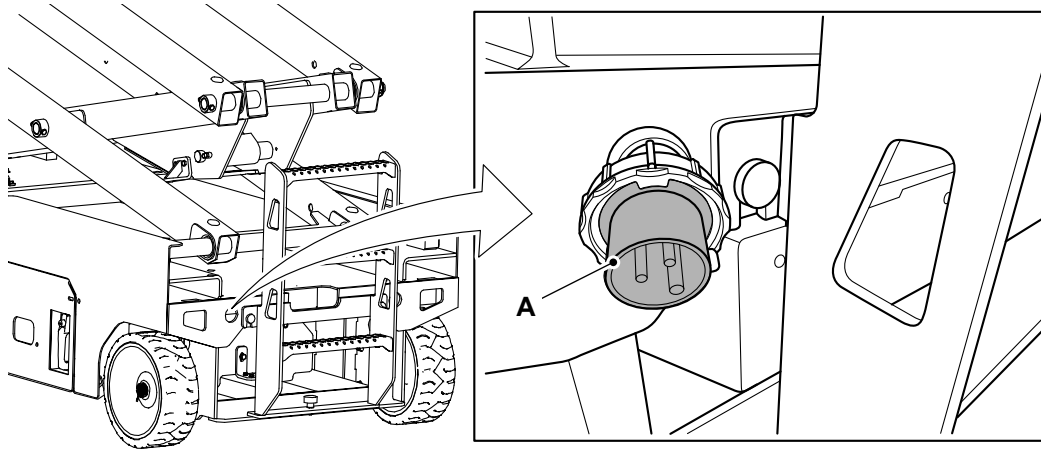
**A** AC (Alternating Current) input socket

Make a note that the AC input socket is located on rear side of the charger.

Only use the original charger installed to the machine with the original batteries. Charge the battery in a well ventilated place. Use an appropriate grounded industrial power supply with the correct AC input voltage to charge.

1. Make sure the battery is properly connected before charging. Check the terminal connections are tight.
2. Remove the ventilation cap and check the electrolyte level is above the polar plate. Replenish with distilled water if required. Do not overfill. Install the ventilation cap.
3. Connect the charger to the AC supply. Refer to Figure 212.
4. When disconnecting the charger make sure that the cable is not pulled or damaged. Hold both the ends of connector when removing.

**Figure 212.**








**A** Battery charging socket

Battery and power to platform connectors may be mounted rigidly in the mounting holes or hung loose with their cables according to configuration.

According to the territories different types of plugs are used on the machine. [Refer to Table 76.](#)

**Table 76.**

Region	Voltage	Color of Plug	Plug Specification	Plug Image
Europe/India	230V	Blue	230 IEC Industrial Plug	
USA	110V	Yellow	110 NEMA5 15P Plug	
UK	110V	Yellow	110 IEC Industrial Plug	

Region	Voltage	Color of Plug	Plug Specification	Plug Image
Europe/South-East Asia	230V	Blue	Wander Schuko - Type Plug	
Australia/New Zealand	250V	Grey	250V/10A AUS Plug	

### Fault Indicator

When a fault occurs, an error code will be displayed on LED (Light Emitting Diode) screen. [Refer to Table 77.](#)

**Table 77.**

Error code	Cause	Remedy
E01 bAt	The battery is not well connected or the battery is connected in reverse or battery is damaged.	<ul style="list-style-type: none"> <li>• Check battery connection is correct.</li> <li>• Check charger connection is correct.</li> <li>• Check each battery is good.</li> </ul>
E02 AC	Abnormal AC Power Input (Voltage)	<ul style="list-style-type: none"> <li>• Check AC input cord is connected between charger and AC outlet.</li> <li>• Make sure AC plug is tightly inserted into the AC outlet and connected to charger correctly.</li> </ul>
E03 Hot	Charger High Temperature Protection	<ul style="list-style-type: none"> <li>• Charger shuts down and goes into protection mode due to charger / environmental temperature too high for charger to function properly. Place the charger into an area with ambient air flow or to a cooler place.</li> <li>• Disconnect the charger and wait for 15–20min before reconnecting for charging.</li> </ul>
E04 bAt	Battery High Temperature Protection	<ul style="list-style-type: none"> <li>• Charger will reduce current or even stop charging when the battery temperature exceeds 50°C (121.9°F). This is to protect the battery from overheating.</li> <li>• When the battery temperature drops, the charging will start automatically.</li> </ul>
E05 Err	Internal error in battery	Replace battery.
E06 bAt	Battery Voltage is too high	Check and ensure that correct output battery voltage is connected.

## Remove and Install

### Special Tools

Description	Part No.	Qty.
6V Battery Lifting Tool	400/J3606	1
12V Battery Lifting Tool	400/K9854	2

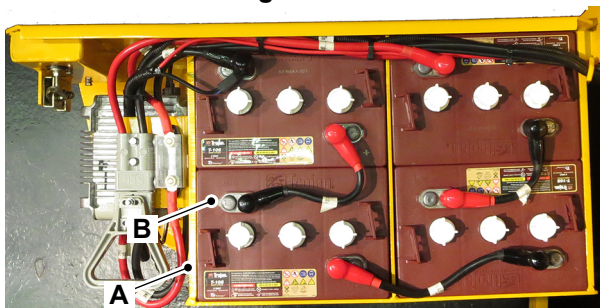
**▲ CAUTION** This component is heavy. It must only be removed or handled using a suitable lifting method and device.

Observe all the battery health and safety information. Refer to: [Health and Safety \(PIL 33-03-00\)](#).

### Remove

1. Make the machine safe.  
Refer to: [Introduction \(PIL 01-03-27\)](#).
2. Open the battery compartment cover.  
Refer to: [Open and Close \(PIL 06-06-03\)](#).
3. Disconnect the battery quick disconnect handle.  
Refer to: [Disconnect and Connect \(PIL 33-05-00\)](#).
4. Disconnect the batteries.  
Refer to: [Disconnect and Connect \(PIL 33-03-00\)](#).
5. Move the battery cables out of the way to allow access to remove the relevant battery.
6. Use the battery lifting tool to carefully remove the battery from the machine.  
Special Tool: 6V Battery Lifting Tool (Qty.: 1)  
Special Tool: 12V Battery Lifting Tool (Qty.: 2)
  - 6.1. Make a note that two persons are required to lift the battery.

**Figure 213.**



- A** Battery compartment  
**B** Battery (x4)

### Install

1. The installation procedure is the opposite of the removal procedure.

## Store and Recommission

Do not keep a lead acid battery inactive for a long period of time.

Make sure that the lead acid battery stays healthy and is ready for use at the time of storage.

It is fine if you charge, store, or operate the lead acid battery on a concrete base.

### Things to Avoid

#### Freezing

Avoid the storage of a lead acid battery, where freezing temperatures are expected.

Put a battery at a high state of charge to prevent freezing. Freezing results in damage to a battery's plates and container.

#### Heat

Avoid direct exposure to heat sources, such as radiators or space heaters.

Temperatures above 26.6°C (79.8°F) accelerate the battery's self-discharge characteristics.

### Step by Step Storage

1. Charge the battery fully before storage.
2. Store the battery in a cool, dry location, protected from the elements.
3. At the time of storage monitor the specific gravity (flooded) or voltage.
4. Batteries in storage should be given a boost charge when they show a 70% charge or less.
5. Fully charge the battery before use.
6. For optimum performance, equalize the batteries (flooded) before you put them back into service.

## 04 - Battery Charger

### 00 - General

Introduction .....	33-141
Technical Data .....	33-142
Component Identification .....	33-143
Operation .....	33-144
Check (Operation) .....	33-145
Calibrate .....	33-147
Charge .....	33-149
Remove and Install .....	33-150

### Introduction

The battery charger is a device used to force the current through the battery to charge it.

The battery charger installed on this machine is a high efficient (up to 94%) unit and has several built in protection systems as follows.

- High AC (Alternating Current) voltage input.
- Low voltage.
- Short circuit.
- Over current.
- Temperature.
- Reverse connection.
- Charging lock.

This battery charger also has a data logger function. It maintains the data that follows. This data can be transferred to and from a USB (Universal Serial Bus) stick.

- Dates and times.
- Input voltage.
- Start and end voltage.
- Battery temperature.

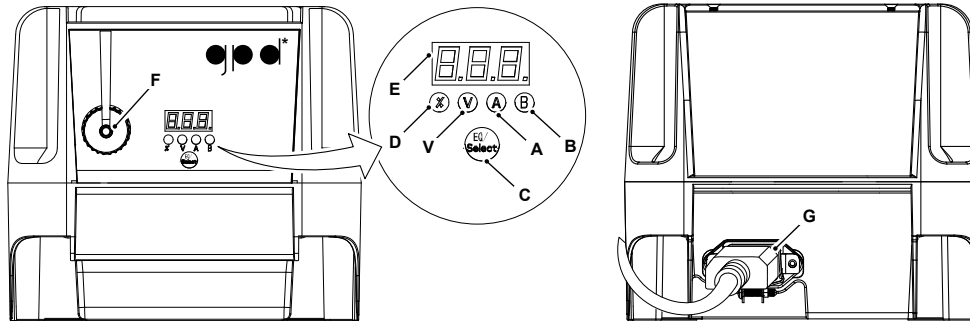
### Equalization

The battery charger will automatically equalize the batteries every 30 days. During this mode, the batteries will be charged at a higher voltage for a longer period than usual. A higher level of gas is expected to be emitted compared to the normal charge cycle. This is normal and non-configurable. This helps to maintain optimum battery condition.

## Technical Data

**Table 78.**

Description	Data
DC (Direct Current) Output	
Nominal voltage	24V
Maximum voltage	34V
Maximum power	750W
Maximum current	30A
AC (Alternating Current) Input	
Nominal voltage	110–240V
Input frequency	50–60Hz
Maximum current	8.5A at 110V
Operating temperature	-20–50°C (-4.0–121.9°F)
Storage temperature	-40–70°C (-39.9–157.9°F)

**Component Identification**
**Figure 214.**


- A** Charging current indicator
- C** EQ/Select button
- E** LED (Light Emitting Diode) display
- G** AC (Alternating Current) input

- B** Battery voltage indicator
- D** Capacity percentage indicator
- F** USB (Universal Serial Bus) port (Under the cap)
- V** Charging voltage indicator

## Operation

### Charging

The charger will switch to charging mode when it is connected to AC (Alternating Current) supply and a battery. The digital display in front panel will cycle between current AC input voltage, software version number and current charging profile code.

Refer to: [Component Identification \(PIL 33-04-00\)](#).

### Charging Profile

1. Press and hold the EQ / Select button for the specified duration to select change charging profile mode.

Duration: 5s

Refer to: [Component Identification \(PIL 33-04-00\)](#).

2. Press the EQ / Select button to cycle through the charging profiles on the digital display.
3. To select the displayed profile press and hold the EQ / Select button for the specified duration.

Duration: 5s

### EQ mode

1. Press and hold the EQ / Select button for the specified duration to select EQ mode. The display will show "EQ".

Duration: 10s

Refer to: [Component Identification \(PIL 33-04-00\)](#).

- 1.1. The next charging cycle will switch to EQ mode.

2. To end EQ mode press and hold the EQ / Select button for the specified duration. The display will show "OFF" and the charger will exit EQ mode.

Duration: 10s

### Charging Status Indicator and Digital Display

Refer to: [Component Identification \(PIL 33-04-00\)](#).

Indicator ON	Description
A	Charging current: Display shows battery charging current.
B	Battery voltage: To check battery voltage, switch off AC supply to the charger while the battery is connected and press EQ / Select button for 1s. Display shows battery voltage.

**Table 79.**

Indicator ON	Description
%	Capacity percentage: Display shows charging percentage of battery.
V	Charging voltage: Display shows battery charging voltage.

## Check (Operation)

1. Do not expose the charger to oil, dirt, mud or direct heavy water spray when cleaning the machine.
2. Check the condition of the input and output wires. If necessary, replace them.
3. Do the following steps when you start charging.
  - 3.1. Connect the charger to battery.
  - 3.2. Connect the charger to AC (Alternating Current) input. The charger will go into charging mode.
4. The charger will show the battery charging status.
  - 4.1. This charger shows the charging status in numerical format on the LED (Light Emitting Diode) display.
2. Connect the charger to AC supply.
3. Insert USB flash drive in the charger USB port.
4. Wait for the charging history to download.
  - 4.1. The screen displays "d.o.n." to indicate download is complete.
5. Pull USB flash drive out from the USB port.
  - 5.1. The history will be stored on the USB flash drive with file name "Serial number.pyl".

## Charging History Data Analysis

1. Download the "Data query" software from the given web address.  
Refer to: [Data query \(supported by NI\)](#).
2. Run document "Data query.exe".
3. Click "OPEN" and browse to the USB flash drive to open file "Serial number.pyl".
4. Click "SAVE" to save the data to the desired location on the computer, and then open the saved file with Microsoft Excel.
5. The charging history data will be displayed. Refer to [Figure 215](#). "Serial number .pyl" includes the following information.

## Charging History Data Download

### Requirement

- USB (Universal Serial Bus) flash drive (capacity not exceeding 64 GB).

### Procedure

1. Format the USB flash drive to FAT32 using a computer.

**Figure 215.**

Date	Curve NO.	Event	Start Time	Start V	Duration	End V	Charged AH	AC Voltage	BTS
15-08-20	b02	Charging Profile Changed Through USB Upload	14:44	--	--	24.18	0	0.8	25
15-08-20	b02	Start Charging	14:44	24.43	--	--	0	122.7	25
15-08-20	b02	Fully Charged	15:03	--	00:19	28.41	6.4	121.5	25
15-08-20	b02	Start Charging	15:04	26.55	--	--	0	121.5	25
15-08-20	b02	Fully Charged	15:05	--	00:01	32.04	0.3	228.5	25
15-08-20	b02	Start Charging	15:06	25.44	--	--	0	228.1	25
15-08-20	b02	AC Voltage Fluctuates Outside Of Operational AC Input Range	15:10	--	00:04	27.34	1.3	268.2	25
15-08-20	b02	Start Charging	15:11	26.51	--	--	0	246.9	25
15-08-20	b02	AC Voltage Fluctuates Outside Of Operational AC Input Range	15:12	--	00:01	27.37	0.3	77.6	25
15-08-20	b02	Start Charging	15:13	26.55	--	--	0	90.7	25
15-08-20	b02	Fully Charged	15:14	--	00:01	32.04	0.5	121	25
15-08-20	b02	Start Charging	15:16	24.97	--	--	0	121	25
15-08-20	b02	Fully Charged	15:16	--	00:00	32.04	0	121	25
15-08-20	b02	Start Charging	15:19	27.34	--	--	0	121	25
15-08-20	b02	Power Interruption	18:52	--	03:33	26.44	80.3	110.8	25
15-08-21	b02	Start Charging	08:43	24.22	--	--	0	229.3	25
15-08-21	b02	Power Interruption	13:49	--	05:06	30.93	133.9	215.3	25
15-08-21	b02	Start Charging	13:50	27.41	--	--	0	226.4	25
15-08-21	b02	Power Interruption	13:50	--	00:00	32.04	0	204.7	25
15-08-21	b02	Start Charging	13:50	27.44	--	--	0	228.1	25
15-08-21	b02	Power Interruption	13:50	--	00:00	32.04	0	202.6	25
15-08-21	b02	Start Charging	13:51	28.88	--	--	0	227.2	25
15-08-21	b02	Power Interruption	13:51	--	00:00	32	0	224.4	25
15-08-21	b02	Start Charging	13:51	27.55	--	--	0	226.8	25
15-08-21	b02	Power Interruption	13:51	--	00:00	32.04	0	215.3	25
15-08-21	b02	Start Charging	13:52	24.22	--	--	0	225.6	25
15-08-21	b02	Power Interruption	17:26	--	03:34	22.53	96	200.2	25
15-08-22	b02	Start Charging	08:07	24.04	--	--	0	228.5	25
15-08-22	b02	Power Interruption	14:17	--	06:10	32.65	142.8	225.6	25
15-08-22	b02	Start Charging	14:18	27.23	--	--	0	228.1	25
15-08-22	b02	Power Interruption	17:11	--	02:53	21.56	77.5	173.9	25

5.1. Date

5.2. Battery Curve Number

5.3. Event

5.4. Charging start time



- 5.5. Battery voltage at charging start
- 5.6. Charging time
- 5.7. Battery voltage at charging end
- 5.8. Charging electric quantity
- 5.9. AC voltage
- 5.10. Battery temperature
- 6. The following events will be recorded in the charging history

**Table 80.**

Start Charging
Fully Charged
Battery Error (Low Voltage Detected)
Battery High Temperature Protection
Charger High Temperature Protection
Enable Power Mode By USB Port
Charging Profile Changed Through USB Upload
Power Interruption
There were voltages difference, The charger could not be start until the voltages are both same.
Battery Overly Discharged (Avg Cell Voltage is lower than 1.5V)
Overtime Termination
Output Current High
Start Equalization
Disable USB Function
Enable USB Function
Null Current Termination
AC Voltage Fluctuates Outside Of Operational AC Input Range

JCB © CONNOR STANMORE - 13/03/2026 07:57.

## Calibrate

### Charge Curves and History

The below procedure is the process to extract historic data from the charger and upload new charge curve data to the charger. This allows you to see the charge history through ServiceMaster, and change the charge parameters to control the battery charger. These should only need to be updated if charger is replaced or battery type or size is changed.

#### To extract data from charger

1. Format the USB (Universal Serial Bus) stick (capacity does not exceed 8GB) to be FAT32.
2. Insert the USB stick to the charger.
3. Wait until the USB status LED (Light Emitting Diode) of charger stops flashing.
  - 3.1. This will download to two files to the USB stick. One file will be saved under a serial number of the charger and other will be PYLODATA.PYL document.
4. If the USB status LED of charger flashes each for specified frequency or specified time, the update work has not completed.
 

Frequency: 1Hz  
Duration: 1s

  - 4.1. The following are the potential reasons.
  - 4.2. Poor contact between the USB and USB port of the charger.
  - 4.3. The USB stick has not been formatted to FAT32.

- 4.4. The USB stick capacity exceeds 8GB.
5. Take out the USB stick from the charger.
6. Access the charger profile data.
  - 6.1. Open the serial number file in Servicemaster battery history tool. This will tell you the code loaded into the PYLODATA.PYL to the dates they were uploaded.
  - 6.2. Check the excel sheet for correct curves to battery type.

#### To update the charger profile

1. Format the USB (capacity does not exceed 8GB) to be FAT32.
2. Upload the new PYLODATA.PYL document into root of USB. [Refer to Table 81.](#)
3. Insert the USB stick to the charger.
4. Wait until the USB status LED of charger stops flashing.
  - 4.1. This will update the battery charger profile.

**Table 81. Battery Category and Program Code Contrast**

Code	Battery
2	TROJAN T105
7	Trojan T125
11	Trojan T1275
114	Vision - EV12-155A-AM
161	Vision - EVGC-220A-AM

**Table 82. Charger Profile Applicability - Standard Battery**

Model/Option	Charger Profile	Batteries
S1932E EDRV	T105 - profile B02	T105
S2632E EDRV	T105 - profile B02	T105
S2646E EDRV	T125 - profile B07	T125
S3246E EDRV	T125 - profile B07	T125
S4046E EDRV	T1275 - profile B11	T1275
S4550E EDRV	T1275 - profile B11	T1275

**Table 83. Charger Profile Applicability - Optional Battery**

Model/Option	Charger Profile	Batteries
S1932E EDRV	161	Vision - EVGC-220A-AM
S2632E EDRV	161	Vision - EVGC-220A-AM
S2646E EDRV	161	Vision - EVGC-220A-AM
S3246E EDRV	161	Vision - EVGC-220A-AM



### 33 - Electrical System

04 - Battery Charger

00 - General

---

Model/Option	Charger Profile	Batteries
S4046E EDRV	161	Vision - EV12-155A-AM
S4550E EDRV	161	Vision - EV12-155A-AM

JCB © CONNOR STANMORE - 13/03/2026 07:57.



## Charge

The battery charging procedure is given in the Electrical System, Battery. Refer to [Refer to: Check \(Level\) \(PIL 33-03-00\)](#).

## Remove and Install

### Battery Charger

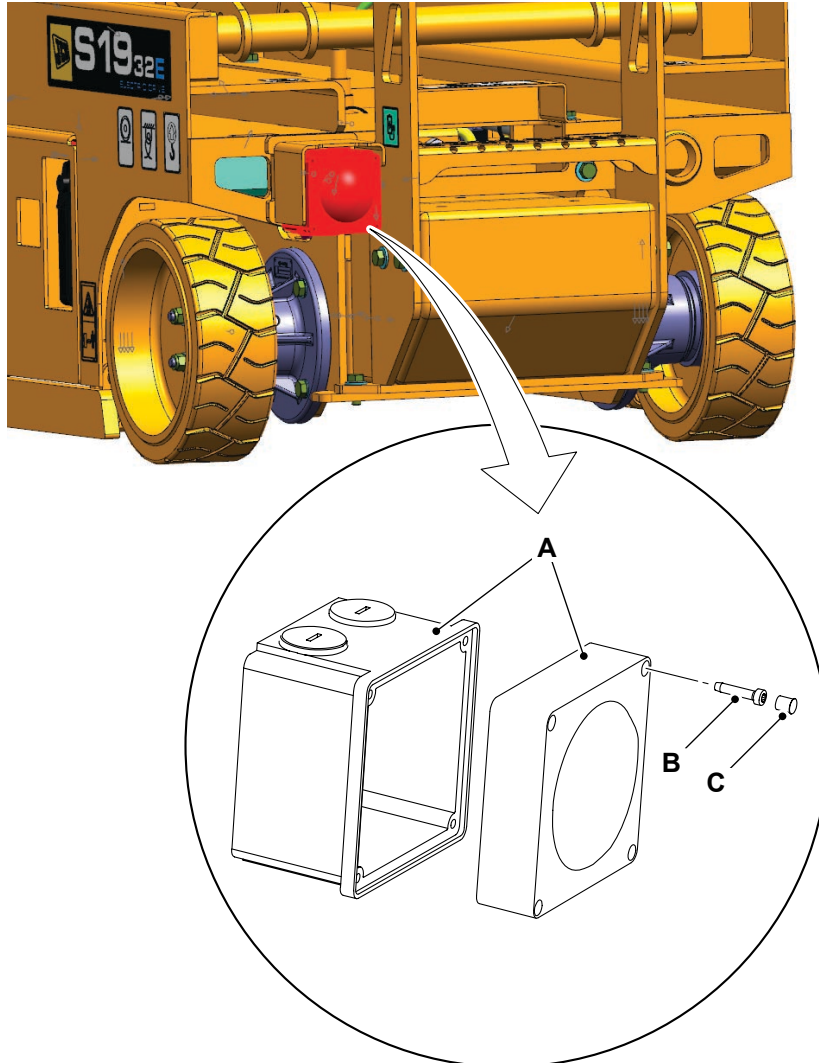
#### Remove

1. Make the machine safe.  
[Refer to: Introduction \(PIL 01-03-27\).](#)
2. Open the battery compartment door.  
[Refer to: Open and Close \(PIL 06-06-03\).](#)
3. Disconnect the battery isolator (pull type/rotary type).  
[Refer to: Disconnect and Connect \(PIL 33-05-00\).](#)
4. Disconnect the batteries.  
[Refer to: Disconnect and Connect \(PIL 33-03-00\).](#)

5. Disconnect the charge cable and temperature probe wire from the batteries.
6. Remove the electrical connections from the charger.
7. Remove the fasteners.
8. Remove the charger from the machine.  
[Refer to: Component Identification \(PIL 33-04-00\).](#)

#### Install

1. The installation procedure is the reverse of the removal procedure.

**10A Plug**
**Figure 216.**


**A** 10A plug  
**C** Insert cap (x4)

**B** Capscrew (x4)

**Remove**

1. Make the machine safe.  
[Refer to: Introduction \(PIL 01-03-27\).](#)
2. Open the battery compartment door.  
[Refer to: Open and Close \(PIL 06-06-03\).](#)
3. Disconnect the battery isolator (pull type/rotary type).  
[Refer to: Disconnect and Connect \(PIL 33-05-00\).](#)
4. Disconnect the batteries.
5. Get access to the 10A plug located near to the ladder on the chassis.
6. Remove the insert cap (x4) and capscrew (x4).  
[Refer to Figure 216.](#)
7. Open the cover and unscrew the live, neutral, and ground wires.
  - 7.1. Make a note of the wire pins to help during installation.
8. Remove the 10A plug. [Refer to Figure 216.](#)

**Install**

1. The installation procedure is the reverse of the removal procedure. Additionally, do the following steps.
2. Connect the live, neutral and ground wires to their related pins.
3. Tighten the capscrew (x4) to the specified torque value.

Torque: 3.6N·m



## 05 - Battery Quick Disconnect

### 00 - General

[Introduction](#) ..... 33-153  
[Disconnect and Connect](#) ..... 33-154

### Introduction

The battery quick disconnect connector allows the operator to connect/disconnect the batteries easily and quickly.

It is a mechanical keyed housing that prevents the accidental mating of the components operating at different voltage levels. It has a flat wiping contact system that allows minimum contact resistance at high current. The wiping action of these connectors also cleans the contact surface during disconnection.

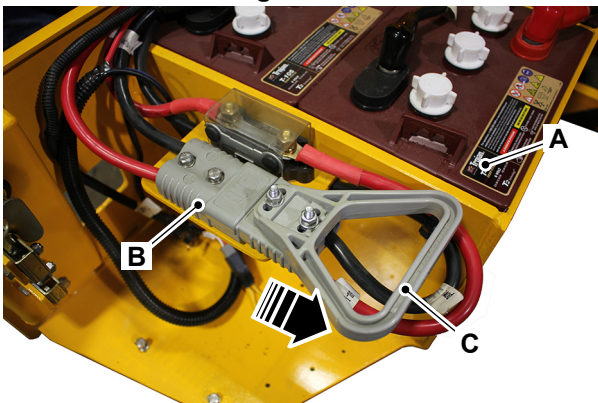
JCB © CONNOR STANMORE - 13/03/2026 07:57.

## Disconnect and Connect

### Disconnect

1. Make the machine safe.  
 Refer to: [Introduction \(PIL 01-03-27\)](#).
2. Open the battery compartment door.  
 Refer to: [Open and Close \(PIL 06-06-03\)](#).
3. Make sure that all the electrical components are switched off.
4. Pull the battery quick disconnect handle in the direction shown. [Refer to Figure 217](#).
  - 4.1. If necessary, hold the other end of the quick disconnect handle.
  - 4.2. Make sure that the connection/disconnection force is within specified limits.  
 Force: 150N
5. Remove the primary fuse from the high power fuse box, otherwise the disconnecter will still be live.
6. Remove the nuts and bolts from the fixed end of the battery quick disconnect.
7. Press the tab within the end of the disconnecter to pull the cable out the opposite side.

**Figure 217.**



- A Battery
- B Battery quick disconnect
- C Handle

### Connect

1. The connection procedure is the opposite of the disconnection procedure.



## 07 - DC Contactor

### 00 - General

Introduction .....	33-155
Component Identification .....	33-156
Remove and Install .....	33-156

### Introduction

The DC (Direct Current) contactor is part of the safety functions. It works like a large relay. It cuts high power to the pump motor ECU (Electronic Control Unit) when a function is not demanded.

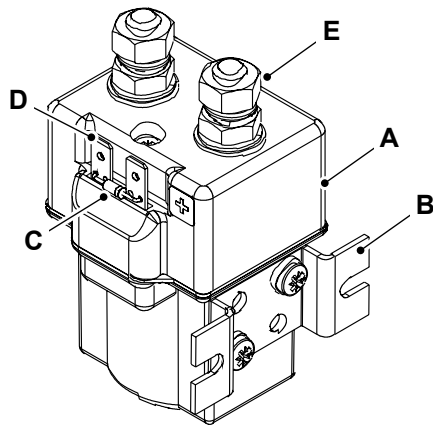
It is controlled by the MECU (Machine Electronic Control Unit) and the motor controller ECU.

If there are any faults, it will not allow the motor to power up so there will be no movement.

JCB © CONNOR STANMORE - 13/03/2026 07:57.

## Component Identification

Figure 218.



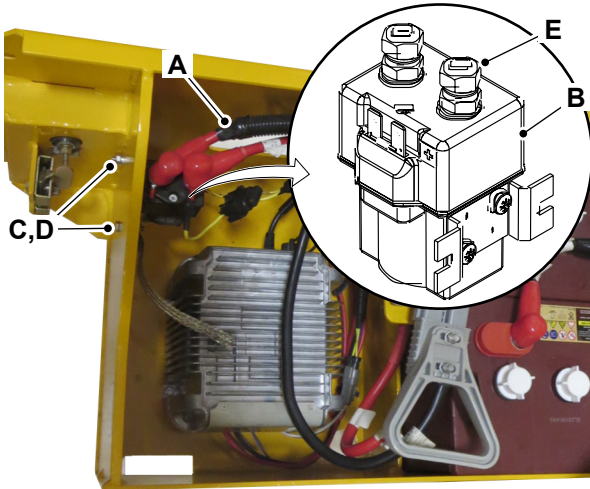
- A** DC (Direct Current) contactor
- B** Mounting bracket
- C** Diode
- D** Coil terminals
- E** Power connections for battery terminals

## Remove and Install

### Remove

1. Make the machine safe with the platform lowered.  
[Refer to: PIL 01-03-27.](#)
2. Open the battery compartment door.  
[Refer to: Open and Close \(PIL 06-06-03\).](#)
3. Disconnect the battery quick disconnect handle.  
[Refer to: Disconnect and Connect \(PIL 33-05-00\).](#)
4. Remove the electrical terminal wires from the wiring harness on the DC (Direct Current) contactor.
  - 4.1. Put a label on the coil terminal wires to help installation. It is very important to connect the coil terminal wires to the correct terminal or it may cause damage to the electrical system.
5. Pull back the red caps to remove the nuts on the DC contactor.
  - 5.1. Make sure that you support the DC contactor. Otherwise you may damage the bracket or DC contactor.
  - 5.2. Remove the bolt (x2), nut (x2) and washers.
  - 5.3. This will release the battery leads on the top of the DC contactor.
6. Disconnect the coil terminal wires.
7. Remove the DC contactor from the machine.

Figure 219.



- A Terminal wires
- B DC contactor
- C Bolt (x2)
- D Nut (x2)
- E Terminal nut

#### Install

1. The installation procedure is the opposite of the removal procedure. Additionally do the following step.
2. Tighten the nuts to the correct torque value.
3. Make sure that you correctly connect the coil terminal wires. If the coil terminal wires are connected wrongly, it may cause damage to the electrical system.

Table 83. Torque Values

Item	Nm
E	8–9.5



## 09 - Power Distribution

### 00 - General

Introduction .....	33-158
Health and Safety .....	33-159

### Introduction

The electrical circuits are protected by fuses. If a fuse blows, find out why and rectify the fault before installing a new one.

JCB © CONNOR STANMORE - 13/03/2026 07:57.

## Health and Safety

▲ **Notice:** Always replace fuses with ones of correct ampere rating to avoid electrical system damage.

**Notice:** When installing auxiliary electrical components always ensure that the additional load rating is suitable for that particular circuit. It is unacceptable to simply increase the fuse rating as this can cause overloading and consequential failure of wiring, along with failure of integral circuit components, which the fuse is protecting.

**03 - Fuse**

**Component Identification**

Component Identification ..... 33-160

Remove and Install ..... 33-162

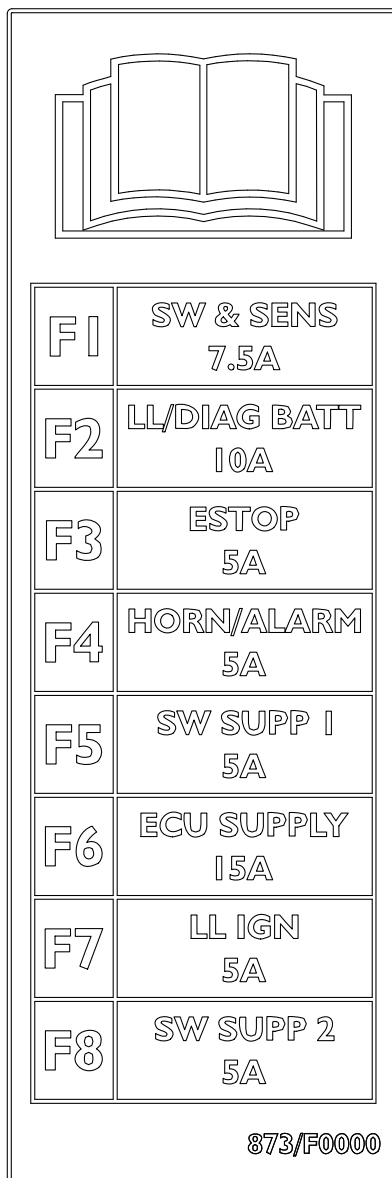
**Primary Fuses**

Table 84.

Fuse	Rating
Primary fuse (high rating)	200A
Primary fuse- single inline (low rating)	30A

**Secondary Fuses**

Figure 220.



JCB © CONNOR STANMORE - 13/03/2026 07:57.

**Table 85.**

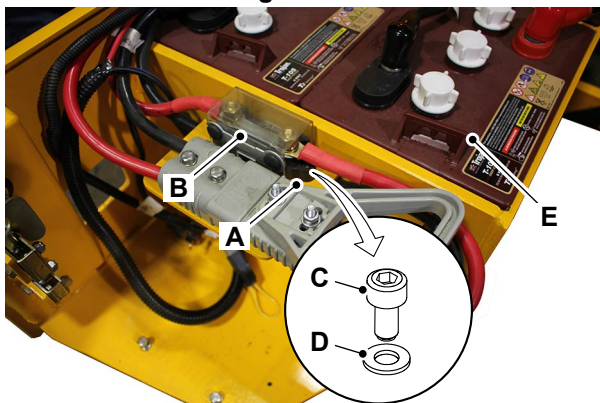
<b>Fuse</b>	<b>Circuit</b>	<b>Rating</b>
F1	Permanent feed - Main ignition relay contact	7.5A
F2	Permanent feed Livelink and Diagnostic battery supply	10A
F3	Permanent feed - Emergency stop, charger switch, ignition switch	5A
F4	Ignition feed - Horn relay	5A
F5	Ignition feed - Enable switch, lower limit switch, Tilt switch, angle sensor, pressure sensor 1, pothole switch (right hand)	5A
F6	Ignition feed - ECU (Electronic Control Unit) ignition relay contact, base display, I/O expansion ECU	15A
F7	Ignition feed - Livelink, ECU ignition relay coil	5A
F8	Ignition feed - Platform Up/Down switch, lower limit switch, upper limit switch, pressure sensor 2, pothole switch (left hand)	5A

## Remove and Install

### Primary Fusebox

#### Remove

1. Make the machine safe.  
[Refer to: Introduction \(PIL 01-03-27\).](#)
2. Isolate the battery.  
[Refer to: Disconnect and Connect \(PIL 33-05-00\).](#)
3. Open the battery compartment door.  
[Refer to: Open and Close \(PIL 06-06-03\).](#)
4. Remove the primary fusebox cover.
5. Remove the nuts from the DC (Direct Current) contactor.  
[Refer to: PIL 33-07.](#)
6. Release the battery positive terminal wire and fuse.
  - 6.1. Be careful when you release the fuse, as other end of the battery is still connected and is live.
7. Remove the capscrew (x2) and washer (x2) from fusebox base.
8. Remove the primary fusebox.

**Figure 221.**


- A Primary fusebox
- B Primary fusebox cover
- C Capscrew (x2)
- D Washer (x2)
- E Battery

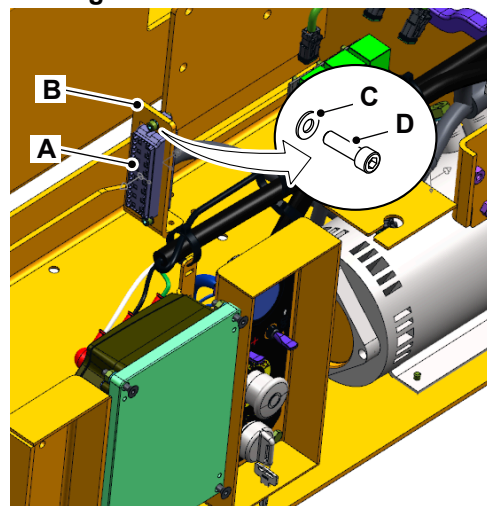
#### Install

1. The installation procedure is the reverse of the removal procedure.

### Secondary Fusebox

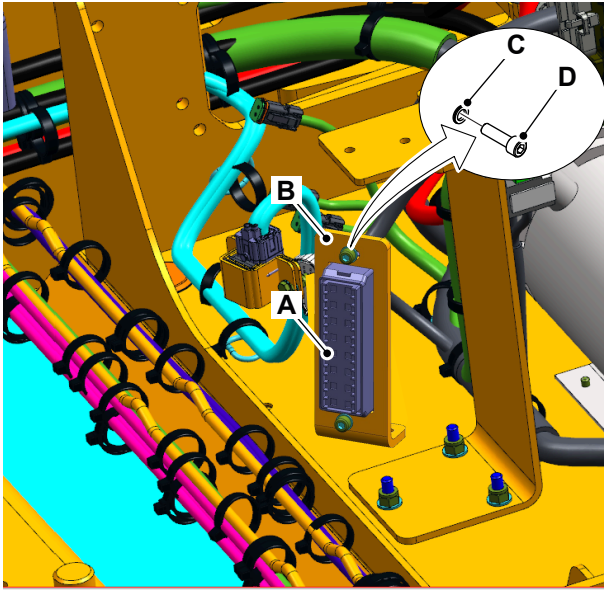
#### Remove

1. Make the machine safe with the platform lowered.  
[Refer to: Introduction \(PIL 01-03-27\).](#)
2. Disconnect the battery quick disconnect handle.  
[Refer to: Disconnect and Connect \(PIL 33-05-00\).](#)
3. Open the hydraulic compartment door.  
[Refer to: Open and Close \(PIL 06-06-09\).](#)
4. Remove the cover.
5. If necessary, remove the fuses from the fusebox.
6. Remove the capscrew (x2) and washer (x2).
7. Remove the fusebox from the machine.
8. Disconnect the wires from the fusebox.

**Figure 222. For S1932E EDRV**


- A Secondary fusebox
- B Bracket
- C Washer (x2)
- D Capscrew (x2)

**Figure 223. For S2632E EDRV, S2646E EDRV, S3246E EDRV, S4046E EDRV, S4550E EDRV**



- A Secondary fusebox
- B Bracket
- C Washer (x2)
- D Capscrew (x2)

#### Install

1. The installation procedure is the reverse of the removal procedure.

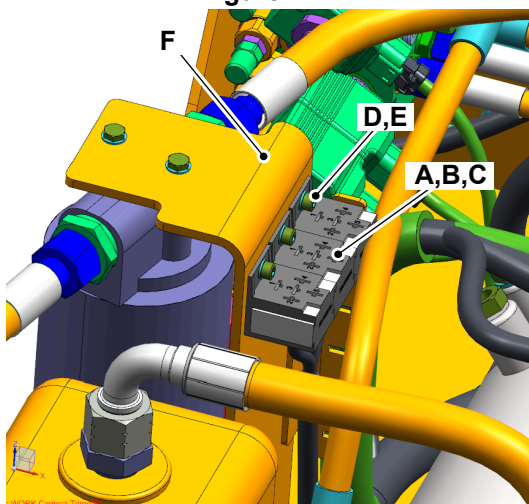
## 06 - Relay

### Remove and Install

#### Remove

1. Make the machine safe with the platform lowered.  
[Refer to: Introduction \(PIL 01-03-27\).](#)
2. Disconnect the battery quick disconnect handle.  
[Refer to: Disconnect and Connect \(PIL 33-05-00\).](#)
3. Open the hydraulic compartment door.  
[Refer to: Open and Close \(PIL 06-06-09\).](#)
4. Remove the relay (x3).
5. Remove the screw (x3) and washer (x3).
6. Disconnect the terminal wires.

**Figure 224.**



- A,B,C** Relay (x3)
- D** Screw (x3)
- E** Washer (x3)
- F** Mounting bracket

#### Install

1. The installation procedure is the opposite of the removal procedure. Additionally do the following step.
2. Before you connect the wires check the condition of the crimped terminals of the wires. If damaged, crimp the wire terminals.

[Refer to: Repair \(PIL 33-12-00\).](#)



## 10 - Motor

### 00 - General

Introduction .....	33-165
Technical Data .....	33-166
Component Identification .....	33-167
Remove and Install .....	33-168

### Introduction

The pump motor installed on this machine is a DC (Direct Current) motor with a series excited permanent magnet.

The resistance between the motor enclosure and any of the binding points is infinite or more than 1 mega ohm.

The pump motor rotates in an anticlockwise direction (viewed from commutator end).

JCB © CONNOR STANMORE - 13/03/2026 07:57.



### Technical Data

For: S1932E EDRV [RAJ], S2632E EDRV [RAJ], S2646E EDRV [RAJ], S3246E EDRV [RAJ] ..... Page 33-166

For: S4046E EDRV [RAJ], S4550E EDRV [RAJ] ..... Page 33-166

(For: S1932E EDRV [RAJ], S2632E EDRV [RAJ], S2646E EDRV [RAJ], S3246E EDRV [RAJ])

**Table 86.**

Description	Data
Rated power	3.3kW
Rated speed	3050 RPM (Revolutions Per Minute)
Input voltage	24V
Rated current	180A
Maximum speed	5600 RPM

(For: S4046E EDRV [RAJ], S4550E EDRV [RAJ])

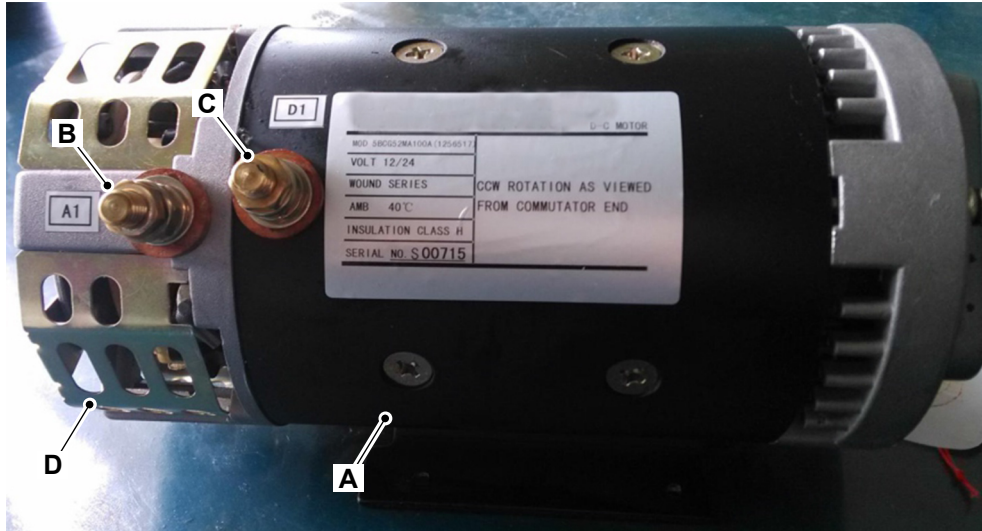
**Table 87.**

Description	Data
Rated power	4.5kW
Rated speed	2700 RPM
Input voltage	24V
Rated current	239A
Maximum speed	5600 RPM

JCB © CONNOR STANMORE - 13/03/2026 07:57.

Component Identification

Figure 225.



- A Pump motor
- C D1 terminal (Negative binding)

- B A1 terminal (Positive binding)
- D Commutator end

JCB © CONNOR STANMORE - 13/03/2026 07:57.

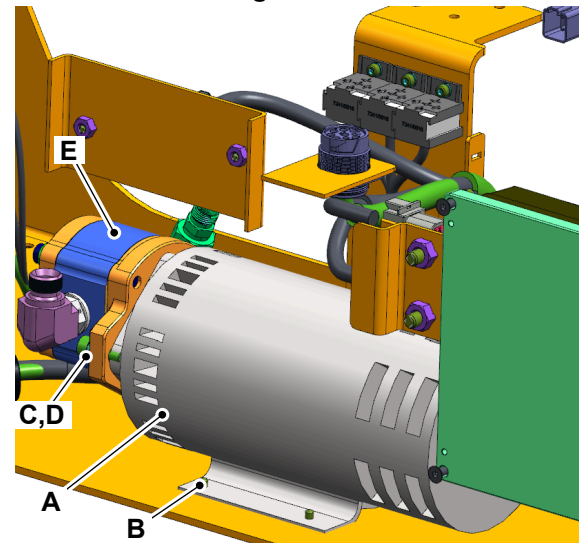
## Remove and Install

**▲ WARNING** You could get killed or injured if you touch the Battery positive and Battery negative terminals of the motor controller. The controller is installed with energy storing devices (capacitors). You must discharge the controller before you remove or install.

### Remove

1. Obey all electrical system health and safety information.  
[Refer to: Health and Safety \(PIL 33-00-00\).](#)
2. Make the machine safe.  
[Refer to: PIL 01-03-27.](#)
3. Disconnect the quick disconnect handle.  
[Refer to: Disconnect and Connect \(PIL 33-05-00\).](#)
4. Disconnect the batteries.  
[Refer to: Disconnect and Connect \(PIL 33-03-00\).](#)
5. Open the hydraulic compartment door.  
[Refer to: Open and Close \(PIL 06-06-09\).](#)
6. Remove the hydraulic tank.  
[Refer to: Remove and Install \(PIL 30-03-00\).](#)
7. Put a label on the hoses and electrical harnesses to help installation.
8. Disconnect the hydraulic hoses and electrical harnesses from the pump motor.
9. Plug all the open ports and hoses to prevent contamination.
10. Remove the bolts 1 (x4) from the underside of the hydraulic compartment.
11. Lift and remove the pump motor assembly clear of the machine.
12. Remove the bolts 2 (x2), Washer 2 (x2).
13. Remove the gear pump from the pump motor.

Figure 226.



- A Pump motor
- B Bolts1(x4)
- C Washer 2 (x2)
- D Bolts 2 (x2)
- E Gear pump

### Install

1. The installation procedure is the opposite of the removal procedure. Additionally do the following steps.
2. Tighten the fasteners to the correct torque value.
3. Check the hydraulic oil level and top up to the correct level.  
[Refer to: Check \(Level\) \(PIL 30-00-00\).](#)



## 12 - Harness

### 00 - General

Introduction .....	33-169
Health and Safety .....	33-170
Component Identification .....	33-171
Diagram .....	33-173
Repair .....	33-173
Check (Condition) .....	33-176

### Introduction

#### Harness Drawings

Drawings are reproduced from production electrical harness drawings. Each harness drawing includes tables showing wire connections and destinations for all the connectors on the harness. To identify the correct harness drawing for a particular machine refer to the relevant Harness Interconnection page for the machine serial number range.

JCB © CONNOR STANMORE - 13/03/2026 07:57.

## Health and Safety

- ▲ **Notice:** When installing auxiliary electrical components always ensure that the additional load rating is suitable for that particular circuit. It is unacceptable to simply increase the fuse rating as this can cause overloading and consequential failure of wiring, along with failure of integral circuit components, which the fuse is protecting.

### Harness Repair (Butane Heater)

- ▲ **WARNING** In addition to the warnings incorporated into this procedure, extreme care should be taken when handling the gas heating tool to ensure that the flame does not damage or set fire to any items in the vicinity of the repair, i.e. other wires, floor panels, floor mats, sound proofing, paintwork, etc. This tool should not be used in any restricted location prohibiting the use of "Naked Flames" or where risk of explosive gas or similar safety parameters apply. No other heat source should be used to attempt a sealed joint.

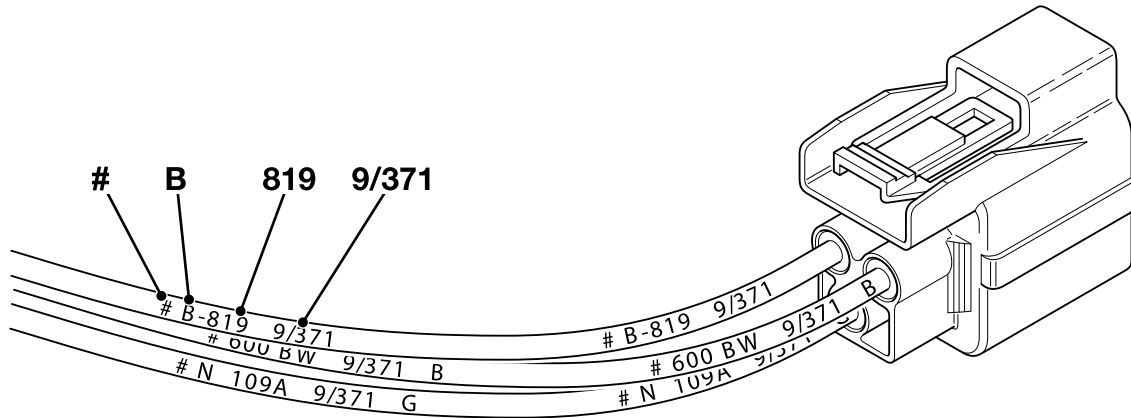
**CAUTION** When the heater is in use, the reflector and the air coming out are extremely hot. Keep away to avoid accidental burns. Do not touch the reflector until it has had time to cool down after switching off. If flame reappears at the reflector when the heater is in use, the catalytic element is damaged or used up. Stop work immediately and replace the heater.

## Component Identification

### Wire and Harness Number Identification

This section details the allocation of wire numbers and the identification of wires in the wiring harness.

Figure 227.



The illustration shows a typical connector and wires. Each wire has an individual identification number permanently marked on it, at regular intervals along its length. The number stamped on the wire identifies the following:

Table 88. Wire and Harness Number Identification

Identification Number	Description
#	The # indicates the start of the identification number. It is always printed to the left of the identification number.
B	If applicable - The colour of the flying lead that the harness wire should mate with. For instance, if wire 819 from harness 719/37100 mated with a flying lead coloured black (colour code B) then the number printed on the wire would be B-819 9/371.

Identification Number	Description
819	The wire's unique identification number. The wire functions and numbers allocated to them are consistent through out the JCB range of products. Refer to Wire Numbers and Functions.
9/371	If applicable - The part number of the harness that the wire originates from. If the harness part number is 719/37100, the number printed on the harness wires will be 9/371 (71 and 00 are common numbers and therefore deleted).

### Wire Numbers and Functions

Table 89. Wires 000-199, 1000-1999 (These numbers are reserved for ignition feeds, heater start circuits and start circuits)

Wire Number	Description
Wires 000 - 099	Unfused ignition feeds
Wires 100 - 199 and 1000 -1999	Fused ignition feeds (feeds via ignition relays are also classed as ignition feeds). Power supplies output by a control module.

**Table 90. Wires 200-399, 2000-3999 (These numbers are reserved for battery feeds)**

Wire Number	Description
Wires 200-299 and 2000-2999	Unfused battery feeds. Power supplies output by a control module.
Wires 300-399 and 3000-3999	Fused battery feeds. Power supplies output by a control module.

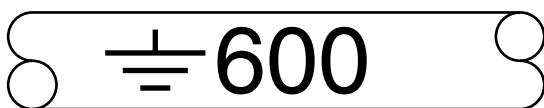
**Table 91. Wires 400-599, 4000-5999**

Wire Number	Description
Wires 400-599 and 4000-5999	These numbers are reserved for instruments, sensors and variable input/output signal wires used in electronic systems. CAN wires also use numbers in this series.

**Table 92. Wires 600-799, 6000-7999**

Wire Number	Description
Wires 600-799 and 6000-7999	These numbers are used for earth wires. When the number is printed on to a wire it is prefixed by the Earth symbol. This symbol is printed onto the wire, it may however be omitted from harness drawings. Where a load is switched negative, the wire number from the load to the switch shall be different to that of the wire from the switch to the earth.

**Figure 228.**



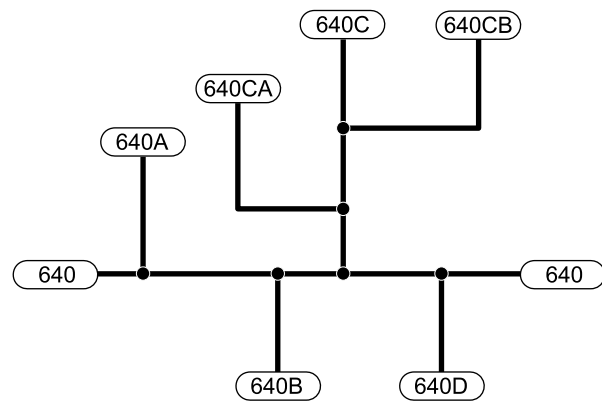
**Table 93. Wires 800-999, 8000-9999**

Wire Number	Description
Wires 800-999 and 8000-9999	These numbers are reserved for switched supplies to electrical loads, i.e. to lights, etc. Power supplies output by a control module.

**Table 94. Wires In Splices**

Wire Number	Description
Various	The main input wire is allocated with a wire number and a suitable description, i.e. Wire 640 earth splice to earth. The additional wires in the splice are allocated the same wire number and a postfix, i.e. 640A, 640B, etc.

**Figure 229.**



**General Points**

1. Wires continue to have the same number even after passing through a connector block to another harness.
2. The descriptions are applicable to JCB specification wiring harnesses. The machine may be installed with some wiring that does not conform to the JCB specifications, typically when it is part of equipment supplied by other manufacturers.

## Diagram

A full set of harness drawings are available.  
 Refer to: [servicepro.jcb.com](http://servicepro.jcb.com).

## Repair

### Special Tools

Description	Part No.	Qty.
<a href="#">Wiring Crimp Tool</a>	<a href="#">892/00349</a>	1
<a href="#">Butane Heater</a>	<a href="#">892/00350</a>	1

### Consumables

Description	Part No.	Size
Wiring Splice (0.5-1.5mm Red, contains 50 off)	892/00351	-
Wiring Splice (1.5-2.5mm Blue, contains 50 off)	892/00352	-
Wiring Splice (3-6mm Yellow, contains 50 off)	892/00353	-
Wiring Splice-Bootlace (1mm Red)	7205/0100	-
Wiring Splice-Bootlace (2.5mm Grey)	7205/0250	-

Instances occur where it is necessary to incorporate auxiliary electrical components into existing electrical circuits and although unlikely with present wiring harnesses, repair or replace specific individual wires within a harness. This will also apply to other machines in addition to those of manufacture.

To make sure that either the inclusion of an auxiliary electrical component or a repair within a harness is completed to an acceptable standard it is strongly recommended that the following tools, equipment and procedures are always used.

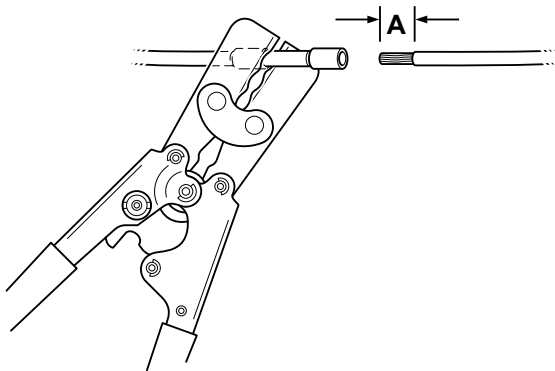
The sheath covering of the recommended splice is heat shrunk onto the original wire insulation. This results in a seal and corresponding joint to IP 67 specifications.

### Procedure 1

1. Cut the wire and remove the protective insulation for a suitable distance dependent upon the size of wire and splice to be used.

[Special Tool: Wiring Crimp Tool \(Qty.: 1\)](#)

**Figure 230.**



**A** Distance for splice (check size)

2. Using the correct sized splice, attach the new section of wire required or auxiliary flying lead to the existing harness and secure using the crimp tool. Note that each of the splices detailed is colour-coded to make size and range readily visible. They are secured using the corresponding size and matching colour-coded jaws of the crimp tool to ensure joint security. This tool also incorporates a ratchet closing mechanism which will not release until the splice is fully closed to the correct compression size.

Consumable: Wiring Splice (0.5-1.5mm Red, contains 50 off)

Consumable: Wiring Splice (1.5-2.5mm Blue, contains 50 off)

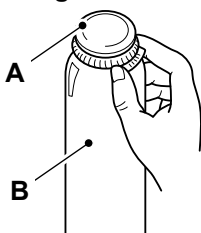
Consumable: Wiring Splice (3-6mm Yellow, contains 50 off)

3. With the Butane heater assembly, seal the connection.

Special Tool: Butane Heater (Qty.: 1)

- 3.1. Remove the cap from the end of the disposable gas cartridge.

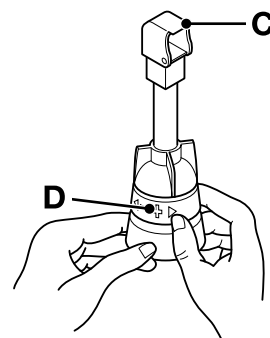
**Figure 231.**



**A** Cap  
**B** Gas cartridge

- 3.2. Before assembling the gas cartridge to the reflector element, turn the red ring to the left, (in the direction of the minus sign marked on the ring).

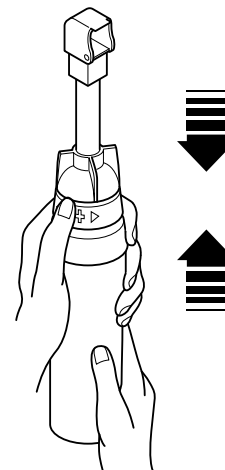
**Figure 232.**



**C** Reflector element  
**D** Red ring

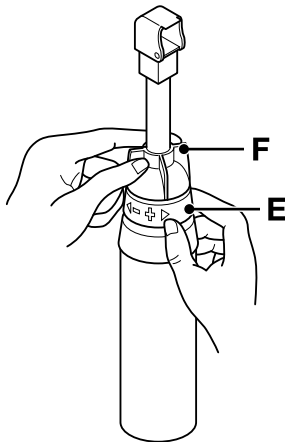
- 3.3. Position the tube hanging down from inside the reflector assembly into the hole at the top of the gas cartridge. Then press the gas cartridge up into the reflector assembly as far as possible until the two elements are clasped firmly together. An audible click will be heard.

**Figure 233.**



- 3.4. Turn the small ring so that the air holes are completely closed.

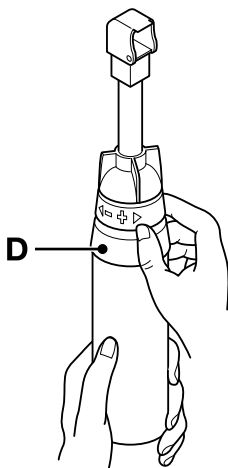
**Figure 234.**



**E** Small ring  
**F** Air holes

- 3.5. Turn the red ring to the right (in the direction of the plus sign) in order to turn on the gas. Important: Before turning the heater on, make sure that the cartridge is not hotter than the reflector element. This may occur if the cartridge is held in the hand for a long time. The temperature difference between the cartridge and the reflector element may cause long yellow flames to appear on ignition.

**Figure 235.**

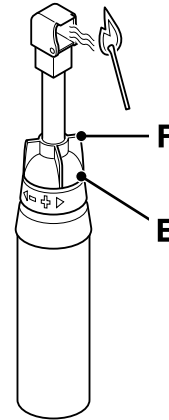


**D** Red ring

- 3.6. Hold the heater vertically and, using a match or cigarette lighter, light the gas as shown. Hold the heater vertically for 1 to 2 minutes until the catalytic reaction occurs. This is indicated when the blue flame fades and the ceramic element glows red. Then turn the small ring until the air holes are completely open. The tool is ready for use. Note: The fact that the sound of liquid cannot be heard when the cartridge is

shaken does not mean it is empty. No sound will be heard even when the cartridge is full.

**Figure 236.**



**E** Small ring  
**F** Air holes

- 3.7. The heater can be used in two modes:  
3.8. Side wings down, reflector head completely open. In this mode the infra-red heat waves are dominant (recommended for the light coloured plastic splices).

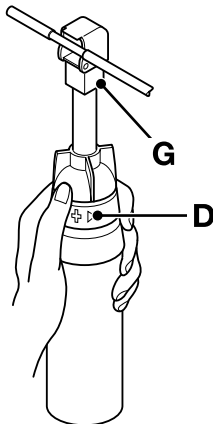
**Figure 237.**



**G** Side wings

- 3.9. Side wings up, reflector head opening reduced. In this mode the heating is done only by the hot gas (use for dark coloured plastic splices).

Figure 238.



- D Red ring
- G Side wings

## Procedure 2

1. Cut the wire and remove the protective insulation for a suitable distance.
2. Install the suitable bootlace ferrule on the wires.  
Consumable: Wiring Splice-Bootlace (1mm Red)  
Consumable: Wiring Splice-Bootlace (2.5mm Grey)
3. Use a suitable bootlace ferrule tool to crimp the terminals. Refer to Figure 239.

Figure 239.



## Check (Condition)

This section describes how to use electrical measuring devices that are used in electrical fault finding.

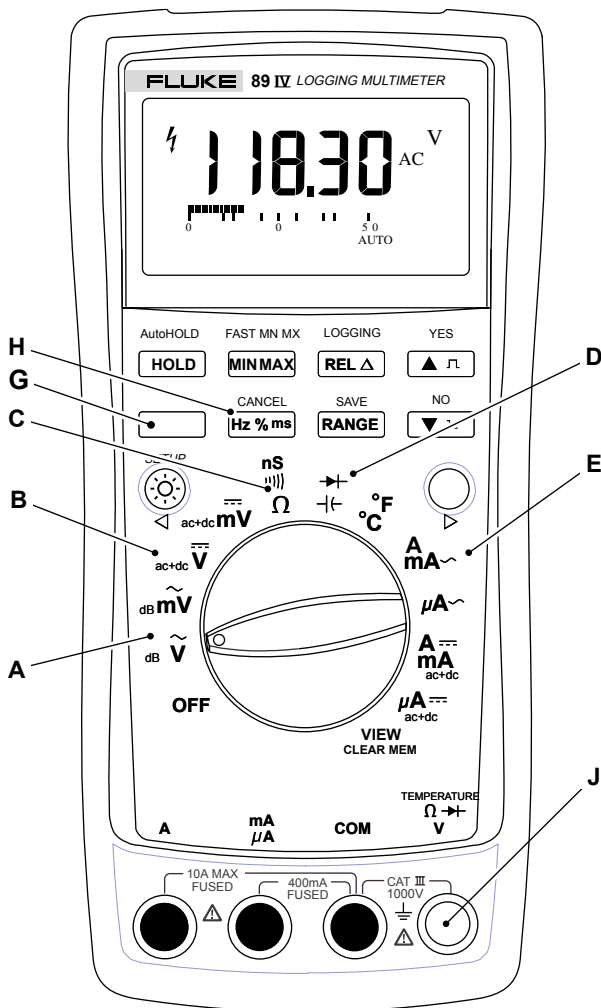
## Use of Multimeters

In order to obtain the maximum benefit from the fault finding information contained in the Electrical Section, it is important that the technician fully understands the approach to fault finding and the use of the recommended test equipment, in this case a digital multimeter, or a moving pointer analogue multimeter. The approach is based on a fault finding check list. In tracing the fault from the symptoms displayed you will be directed to make measurements using a multimeter. These instructions are intended to cover the use of the recommended meters.

1. Make sure that the test leads are plugged into the correct sockets. The black test lead should be plugged into the black socket (sometimes, this socket is also marked by a -, or E or marked as COMMON or COM). The red test lead should be plugged into the red socket marked with +, V or  $\Omega$ .
2. When you make a measurement, make sure that the test probes have a good clean contact with bare metal, free from grease, dirt, and corrosion as these can cause a false reading.
3. When you measure a voltage, make sure that the correct range is selected, that it is set to the selector value equal to or greater than that you are about to measure. e.g. If asked to measure 12 Volts, set the selector to the 12V range. If there is no 12V range, set the selector to the next range higher, 20V for instance. If the meter is set to a range that is too low, it may be damaged. e.g. setting to the 2V range to measure 12V.

## Measuring DC Voltage

1. Select the correct range on the multimeter.
  - 1.1. On the digital multimeter, turn the switch to position B.

**Figure 240. Typical Digital Multimeter**


2. Connect the black probe to the nearest available suitable earth point, usually this will be the starter motor earth, the battery negative, or the chassis. Connect the red probe to the wire or contact from which you are measuring the voltage.

### Measuring Resistance

1. Make sure that there is no power to the part of the circuit you are about to measure.
2. Connect one probe at one end of the component or wire to be checked and the other probe at the other end. It does not matter which way round the two probes are placed.
3. Select the correct range on the multimeter.
  - 3.1. Turn the switch to position C and check that the  $\Omega$  sign at the right hand side of the display window is on. If the F sign is on instead, press the blue button G to change the reading to  $\Omega$ . Touch the meter lead probes together and press the REL3 key on

the meter to eliminate the lead resistance from the meter reading.

### Measuring Continuity

1. Make sure that there is no power to the part of the circuit you are checking for continuity.
2. Connect one probe to one end of the component or wire to be checked and the other probe to the other end. It does not matter which way round the two probes are placed.
3. Select the correct range on the multimeter.
  - 3.1. On the digital multimeter, turn the switch to position C and check that the beeper symbol appears at the left hand side of the display window. If the F sign is on instead, press the button labelled F. If there is continuity in the circuit, the beeper will sound. If there is no continuity (open circuit), the beeper will not sound.

### Measuring Frequency

1. Insert the black plug into the COM socket on the meter and attach the probe to the nearest suitable earth point on the chassis, for example, the battery negative terminal.
2. Insert the red probe into socket J.
3. Turn the selector switch to position A and depress G repeatedly until F is highlighted on the top row of the display.
4. Press button H once.
5. Touch or connect the red probe to the frequency source to be measured. Press and hold the button if an average reading is required.

### Testing a Diode or a Diode Wire

A diode wire is a diode with male connector installed on one end and a female connector installed on the other end. The diode is sealed in heatshrink sleeving. To test a Diode or a Diode Wire.

1. On the digital multimeter:
  - 1.1. Turn the switch to position D.
  - 1.2. Press the HOLD button and check that the H sign appears at the top right hand side of the display window.
  - 1.3. Connect the black probe to the end of the diode with a band or to the male connector of the diode wire. Connect the red probe to the other end of the diode or diode wire. If the beeper does not sound the diode or diode wire is faulty.



- 1.4. Connect the red probe to the end of the diode marked with a band, or to the male connector of the diode wire, the black probe should be connected to the other end of the diode or diode wire. If the beeper sounds or the meter does not read O.L., the diode or diode wire is faulty.
- 1.5. Press the HOLD button and check that the H sign disappears from the right hand side of the display window.

## 15 - Alarm

### 00 - General

#### Remove and Install

For: S1932E EDRV [RAJ] ..... Page 33-179

For: S2632E EDRV [RAJ], S2646E EDRV [RAJ], S3246E EDRV [RAJ], S4046E EDRV [RAJ], S4550E EDRV [RAJ] .... Page 33-180

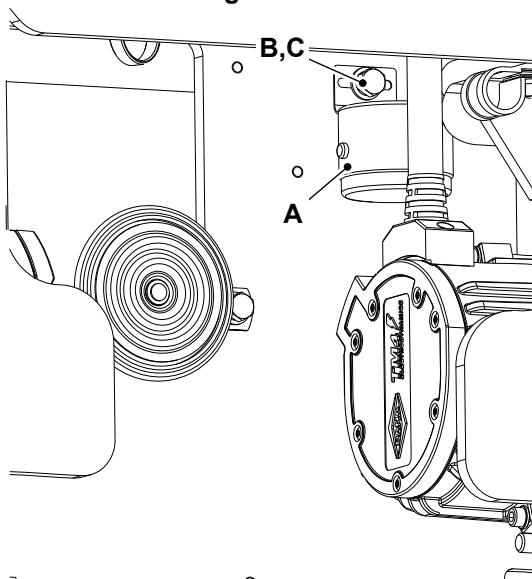
(For: S1932E EDRV [RAJ])

#### Reverse Alarm

##### Remove

1. Make the machine safe.  
[Refer to: Introduction \(PIL 01-03-27\).](#)
2. Disconnect the quick disconnect handle.  
[Refer to: Disconnect and Connect \(PIL 33-05-00\).](#)
3. Locate the alarm behind the drive motors.
4. Disconnect the electrical connector from the alarm.
5. Remove the setscrew and washer.
6. Remove the alarm from the machine.

**Figure 241.**



- A** Alarm
- B** Setscrew
- C** Washer

##### Install

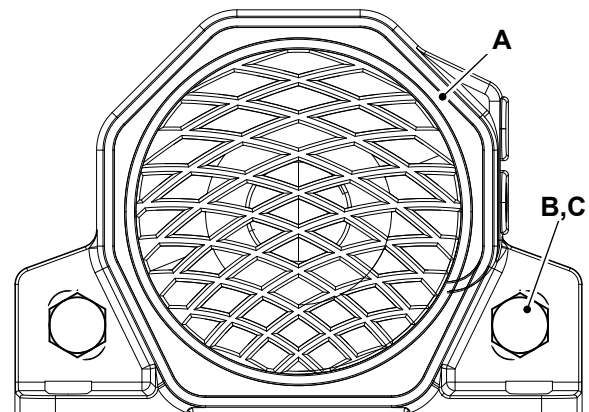
1. The installation procedure is the opposite of the removal procedure.

#### White Noise Buzzer

##### Remove

1. Make the machine safe.  
[Refer to: Introduction \(PIL 01-03-27\).](#)
2. Disconnect the quick disconnect handle.  
[Refer to: Disconnect and Connect \(PIL 33-05-00\).](#)
3. Locate the buzzer behind the drive motors.
4. Disconnect the electrical connector from the buzzer.
5. Remove the setscrew (x2) and washer (x2).
6. Remove the buzzer from the machine.

**Figure 242.**



- A** Buzzer
- B** Setscrew (x2)
- C** Washer (x2)

##### Install

1. The installation procedure is the opposite of the removal procedure.

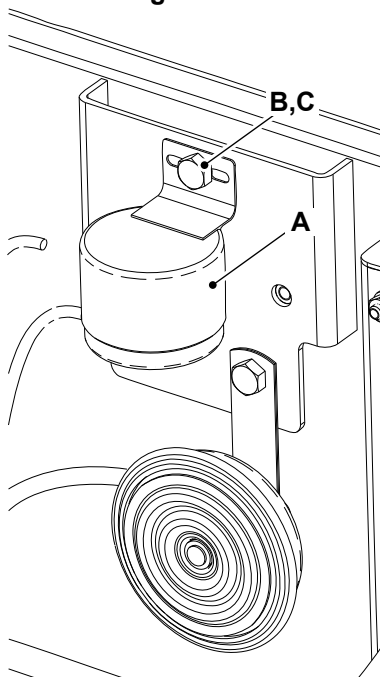
(For: S2632E EDRV [RAJ], S2646E EDRV [RAJ], S3246E EDRV [RAJ], S4046E EDRV [RAJ], S4550E EDRV [RAJ])

### Reverse Alarm

#### Remove

1. Make the machine safe.  
Refer to: [Introduction \(PIL 01-03-27\)](#).
2. Disconnect the quick disconnect handle.  
Refer to: [Disconnect and Connect \(PIL 33-05-00\)](#).
3. Open the hydraulic compartment door.  
Refer to: [Open and Close \(PIL 06-06-09\)](#).
4. Disconnect the electrical connector from the alarm.
5. Remove the setscrew and washers.
6. Remove the alarm from the machine.

**Figure 243.**



- A** Alarm
- B** Setscrew
- C** Washers

#### Install

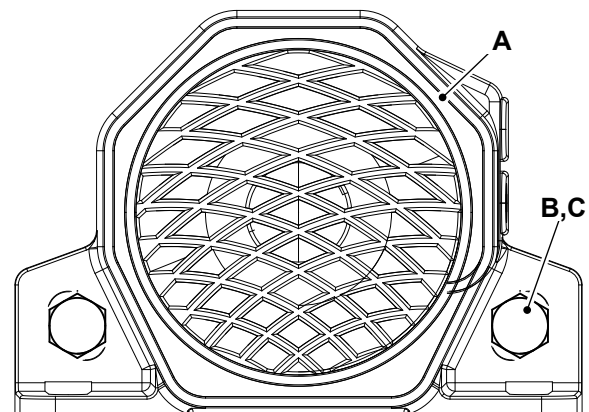
1. The installation procedure is the opposite of the removal procedure.

### White Noise Buzzer

#### Remove

1. Make the machine safe.  
Refer to: [Introduction \(PIL 01-03-27\)](#).
2. Disconnect the quick disconnect handle.  
Refer to: [Disconnect and Connect \(PIL 33-05-00\)](#).
3. Open the hydraulic compartment door.  
Refer to: [Open and Close \(PIL 06-06-09\)](#).
4. Disconnect the electrical connector from the buzzer.
5. Remove the setscrew (x2) and washer (x2).
6. Remove the buzzer from the machine.

**Figure 244.**



- A** Alarm
- B** Setscrew (x2)
- C** Washers (x2)

#### Install

1. The installation procedure is the opposite of the removal procedure.



## 24 - Instruments

### 04 - Control Panel

Introduction .....	33-181
Component Identification .....	33-182
Check (Operation) .....	33-182
Remove and Install .....	33-183

### Introduction

The ground controls are used to operate the machine from the ground, it can also be used to modify the performance of the machine. The ground controls consist of an ECU (Electronic Control Unit), emergency stop button, key switch and circuit breaker.

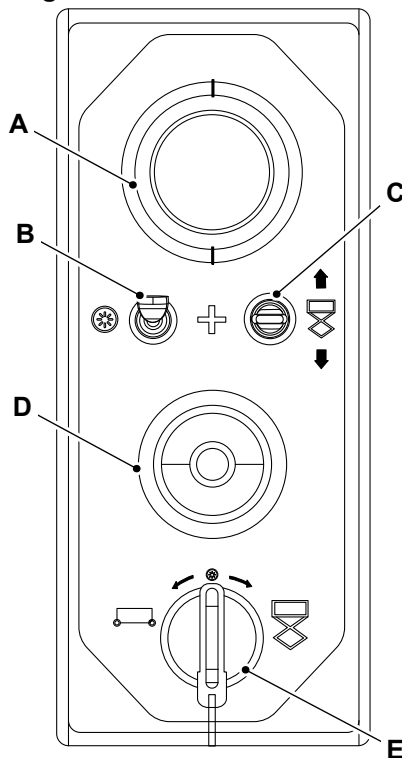
Activating the function enable switch and the up or down at the same time, sends a signal to the ECU .This allows the platform to be raised or lowered at the ground controls.

When the ECU is in the set-up mode, the ground controls are used to adjust the machine options.

JCB © CONNOR STANMORE - 13/03/2026 07:57.

## Component Identification

Figure 245. Ground Controller



- A Base display
- B Enable switch
- C Up/down toggle switch
- D Emergency stop switch
- E Ignition ON/OFF switch

## Check (Operation)

### Machine Key Switch

1. Make the machine safe with the platform lowered.  
Refer to: [PIL 01-03-27](#).
2. Pull out the platform emergency stop button to the ON position.
3. Pull out the ground emergency stop button to the ON position.
4. Turn the machine key to the ground control position and do the following.
  - 4.1. Make sure that the power supply indicator light illuminates.
  - 4.2. Make sure that the platform control becomes inactive.
5. Turn the machine key to the platform control position and do the following.
  - 5.1. Make sure that the power supply indicator light illuminates.
  - 5.2. Make sure that the ground control becomes inactive.
6. Turn the machine key to the OFF position and do the following.
  - 6.1. Make sure that no power supply indicator light illuminates.
  - 6.2. Make sure that all controls become inactive.

### Control Panel Functional Test

1. Make the machine safe with the platform lowered.  
Refer to: [PIL 01-03-27](#).
2. Turn the machine key to the ground control position and do the following.
  - 2.1. Make sure that all the ground controls operate normally. Refer to Operator's manual.
3. Check the operation of the platform emergency stop.
  - 3.1. Pull out the platform emergency stop button to the ON position.
  - 3.2. Pull out the ground emergency stop button to the ON position.
  - 3.3. Turn the ignition key to ground control position.
  - 3.4. Press the ground emergency stop switch.

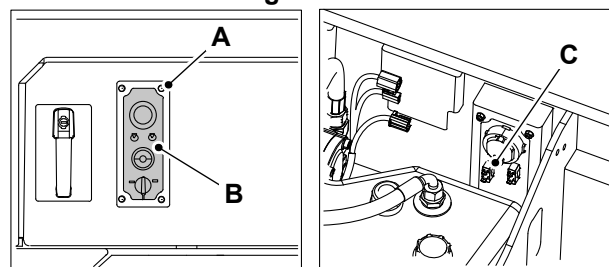
- 3.5. Try to operate/move the machine with ground controls.
  - 3.6. Make sure that the machine does not operate/ move.
  - 3.7. Turn the ignition key to platform control position.
  - 3.8. Try to operate/move the machine with the platform controls.
  - 3.9. Make sure that the machine does not operate/ move.
4. Turn the machine key to the OFF position

## Remove and Install

### Remove

1. Make the machine safe with the platform lowered.  
[Refer to: PIL 01-03-27.](#)
2. Make sure that the emergency stops are in OFF position.
3. Disconnect the battery quick disconnect handle.  
[Refer to: Disconnect and Connect \(PIL 33-05-00\).](#)
4. Open the hydraulic compartment door.  
[Refer to: Open and Close \(PIL 06-06-09\).](#)
5. Remove the screws (x4) and nuts (x4).
6. Carefully remove the ground control panel out of the aperture.
7. Disconnect the electrical connection.
8. Remove the ground control panel.

**Figure 246.**



- A** Screws (x4)
- B** Ground control panel
- C** Electrical connection

### Install

1. The installation procedure is the opposite of the removal procedure. Additionally do the following steps.
2. Tighten the nuts to the correct torque value.



## 05 - Platform Controller

Introduction .....	33-184
Component Identification .....	33-185
Operation .....	33-185
Check (Level) .....	33-186
Check (Operation) .....	33-187
Calibrate .....	33-188
Remove and Install .....	33-195

## Introduction

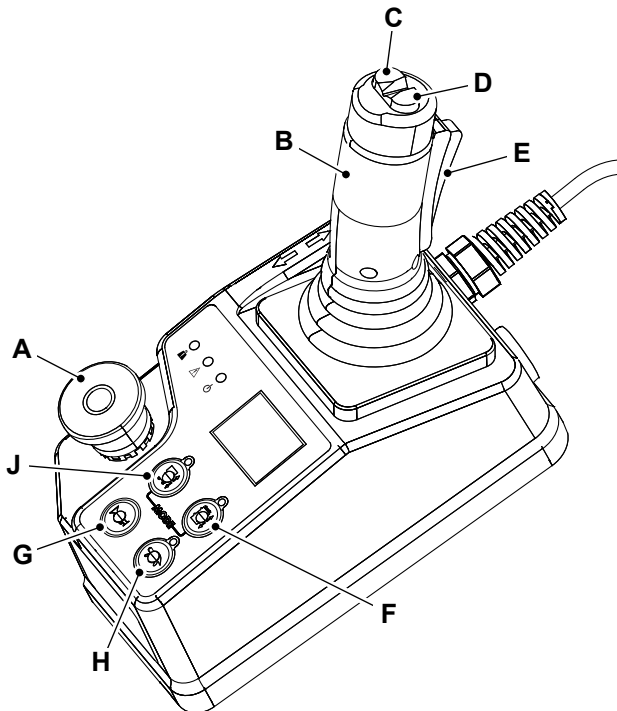
The platform controller is installed in the platform on the front right corner of the machine.

The platform controller consists of a joystick, emergency stop button, mode buttons (drive mode and lift mode), horn, speed selection button and a display.

JCB © CONNOR STANMORE - 13/03/2026 07:57.

## Component Identification

Figure 247.



- A Emergency stop button
- B Joystick (forwards/backwards)
- C Turn left switch
- D Turn right switch
- E Safety trigger/enable switch
- F Drive mode button
- G Horn button
- H Drive speed button
- J Lift mode button

## Operation

### Diagnostic Menu

1. Turn the machine ON.
2. Press and hold Drive mode button and Lift mode button on startup.

Refer to: [Component Identification \(PIL 33-24-05\)](#).

- 2.1. Hold the buttons until Main menu is displayed.

- 2.2. This is the Diagnostic menu.

Refer to: [Calibrate \(PIL 33-24-05\)](#).

3. The Drive mode button is used as enter button.

Refer to: [Component Identification \(PIL 33-24-05\)](#).

4. The turn left switch and turn right switch are used to increase/decrease values.

Refer to: [Component Identification \(PIL 33-24-05\)](#).

5. The Safety trigger/enable switch is used to select the digit of passcode to change.

Refer to: [Component Identification \(PIL 33-24-05\)](#).

6. The Lift mode button is used for up command in menu structure.

Refer to: [Component Identification \(PIL 33-24-05\)](#).

7. The Horn button is used for down command in menu structure.

Refer to: [Component Identification \(PIL 33-24-05\)](#).

8. The Tortoise mode button is used for return command in menu structure.

Refer to: [Component Identification \(PIL 33-24-05\)](#).

- 8.1. When in menu structure you cannot exit using return command (Tortoise mode button), a machine restart is required.

Voltage: 10–20V

### Service Mode

Make sure that the machine is on firm, level and flat ground before operating the Service mode.

The Service mode menu option is available in the OEM Settings which allows machine lift/lower operations in case of any sensor or switch failure

to improve serviceability access. This menu is only accessible by a passcode.

Refer to: [Calibrate \(PIL 33-24-05\)](#).

The Service mode menu option can be enabled as 'ON' for one power cycle only. After selecting ON in the menu, one power cycle is needed to activate the Service mode. It will be disabled automatically when the machine restarts.

Enabling this option 'ON' will only allow for raising or lower operation during the following fault scenarios to create accessibility for repairing the components.

- If either of the pressure sensor outputs goes out of range.
- If the pressure sensor values differ.
- If the angle sensor output goes out of range.
- If there is a mechanical or hardware failure, the angle sensor output does not change for a defined time, but the down limit contacts change.
- If the down limit switch is stuck and does not change relative to the angle sensor.
- If the up limit switch is stuck or prevents the raise operation.
- Overload fault scenario.
- Pothole fault scenario.

When the Service mode is active, the chassis display will show the following screen flashing at a rate of 0.5s.

**Figure 248.**



Also, when the Service mode is active and any operation is in progress, buzzer will beep for 0.25s, then mute for 0.25s, and repeat. The flashing light will flash at 2Hz (ON for 0.25s and then OFF for 0.25s).

**Important:** Service mode is only intended for providing accessibility for repair/replace components such as angle sensors, pressure sensors, limit switches etc. In the Service mode, critical safety features such as overload, potholes etc. are disabled. All operators must be adequately trained and authorised to operate the service mode.

**Note:** When the Service mode is active, the machine should be raised to the height necessary to engage the mechanical safety strut for repair/maintenance purposes. Make sure not to use the machine for regular operation or lift the machine to its full height. It is recommended that the Service mode be operated only from the ground (preferably from the base control panel).

## Check (Level)

The platform controller shows the level of battery charge.

Refer to: [Check \(Level\) \(PIL 33-03-00\)](#).

## Check (Operation)

### Platform Control Functional Test

1. Make the machine safe with the platform lowered.  
[Refer to: PIL 01-03-27.](#)
2. Release the platform emergency stop switch.
3. Release the ground emergency stop switch.
4. Turn the ignition key to the platform control position and do the following.
  - 4.1. Make sure that all the platform controls operate normally. Refer to Operator's manual.
5. Check the operation of the platform emergency stop.
  - 5.1. Release the platform emergency stop switch.
  - 5.2. Release the ground emergency stop switch.
  - 5.3. Turn the ignition key to ground control position.
  - 5.4. Press the platform emergency stop switch.
  - 5.5. Try to operate/move the machine with ground controls.
  - 5.6. Make sure that the machine does not operate/ move.
  - 5.7. Turn the ignition key to platform control position.
  - 5.8. Try to operate/move the machine with the platform controls.
  - 5.9. Make sure that the machine does not operate/ move.
6. Turn the ignition key to the OFF position.



## Calibrate

### User Adjustments and Lift Set Up

1. Make the machine safe with the platform lowered.

Refer to: [PIL 01-03-27](#).

2. Make sure that the emergency stops are in OFF position.

3. Access the diagnostic menu.

Refer to: [Operation \(PIL 33-24-05\)](#).

Table 95.

Screen	Command	Graphic	Description
Main menu		<div style="border: 1px solid black; padding: 5px;"> <b>Main Menu</b>                      › OEM Settings                      OPR Settings                      Fault History                 </div>	Displays when the diagnostic menu access is successful. Use the lift mode button to move up and horn button to move down the menu, and drive mode button for enter.
	OEM Settings		Select to access the diagnostic menu settings.
	OPR Settings		Select to access the operator menu settings.
	Fault History		Select to display the list of errors generated.
OEM settings	Enter Password:	<div style="border: 1px solid black; padding: 5px;"> <b>OEM Settings</b>                      › Enter Password:                      Cancel                 </div>	Select to enter the passcode to enter the diagnostic menu. Contact JCB dealer for passcode.
	Cancel		Select to exit the main menu.
Input password		<div style="border: 1px solid black; padding: 5px;"> <b>Input Password</b>                      XXXX                 </div>	Use the safety trigger/enable switch to select digit, turn left/turn right switch to increase/decrease value, and drive mode button for enter.
OEM settings		<div style="border: 1px solid black; padding: 5px;"> <b>OEM Settings</b>                      Speed Settings                      Machine Options                      › Cal Settings                 </div>	Displays when the correct passcode is entered. Use the lift mode button to move up and horn button to move down the menu, and drive mode button for enter.
	Speed Settings		Select to enter the speed settings menu.
	Machine Options	<div style="border: 1px solid black; padding: 5px;">                     › Height Mode                      Service Mode                      Cancel                 </div>	Select to enter the machine options menu.
	Cal Settings		Select to enter the calibration settings menu.
	Height Mode		Select to enter the height mode menu.
	Service Mode		Select to enter the service mode.
	Cancel		Select to exit the OEM settings main menu.

JCB © CONNOR STANMORE - 13/03/2026 07:57.



Screen	Command	Graphic	Description
Speed settings		<div style="border: 1px solid black; padding: 5px;"> <b>Speed Settings</b>            › Fast 100.0%            Slow 50.0%            Elevated 17.2%         </div>	Use the lift mode button to move up and horn button to move down the menu, and drive mode button for enter.
	Fast	<div style="border: 1px solid black; padding: 5px;">           ›Lift Speed 0%            Steer Speed40%            Acc HS 2.0s            Acc LS 3.0s         </div>	Select to set the maximum machine travel speed in the fast speed mode. Use turn left/turn right switch to increase/decrease value, and drive mode button for enter.
	Slow	<div style="border: 1px solid black; padding: 5px;">           ›Decel 0.1s            Cancel         </div>	Select to set the maximum machine travel speed in slow speed mode. Use turn left/turn right switch to increase/decrease value, and drive mode button for enter.
	Elevated		Select to set the maximum machine travel speed when platform is elevated. Use turn left/turn right switch to increase/decrease value, and drive mode button for enter.
	Lift Speed		Select to set the maximum elevation/descent speed of platform. Use turn left/turn right switch to increase/decrease value, and drive mode button for enter.
	Steer Speed		Select to set the maximum steer speed. Use turn left/turn right switch to increase/decrease value, and drive mode button for enter.
	Acceleration High Speed		Select to set the Acceleration in hare mode. Use turn left/turn right switch to increase/decrease value and drive mode button for enter
	Acceleration Low Speed		Select to set the acceleration in tortoise mode. Use turn left/turn right switch to increase/decrease value and drive mode button for enter
	Deceleration		Select to set the deceleration in drive mode. Use turn left/turn right switch to increase/decrease value and drive mode button for enter
	Cancel		Select to exit the speed settings menu.

JCB © CONNOR STANMORE - 13/03/2026 07:57.



Screen	Command	Graphic	Description
Machine options		<b>Machine Options</b> › PH Alarm    On Descent Del   Off Load Sense   On	Use the lift mode button to move up and horn button to move down the menu, and drive mode button for enter.
	PH Alarm		Select to set the pothole alarm ON/OFF. Use turn left/turn right switch to change value, and drive mode button for enter.
	Descent delay	<b>Machine Options</b> › Miscellaneous	Select to set the platform descent delay ON/OFF. Use turn left/turn right switch to change value, and drive mode button for enter.
	Load Sense		Select to set the load sensing ON/OFF. Use turn left/turn right switch to change value, and drive mode button for enter.
	Miscellaneous		Select to enter the miscellaneous settings menu.
Miscellaneous		<b>Miscellaneous</b> › Jstk Dir    INV Foot Sw    Off Ovr Prvt    Off	Use the lift mode button to move up and horn button to move down the menu, and drive mode button for enter.
	Joystick Direction <sup>(2)</sup>		The menu has 2 options, NOR = Normal and INV = Inverted. The joystick direction for lift/lower operation will be inverted if this is changed to INV.
	Foot Switch <sup>(2)</sup>	<b>Miscellaneous</b> Jstk Dir    INV › Foot Sw    On Ovr Prvt    Off	This is only applicable to machines that have a foot pedal installed. To turn this ON, the foot pedal needs to be pressed along with the joystick to drive or lift the machine.
	Override Prevention <sup>(2)</sup>	<b>Miscellaneous</b> Jstk Dir    INV Foot Sw    Off › Ovr Prvt    On	This is only applicable to machines fitted with an override prevention system.
	Cutout <sup>(2)</sup>	› Cutout    LFT Elvt Drv    Off Dual Hght   Off Cancel	If override prevention is activated and LFT is appearing on the display, the machine lift will be disabled until the override condition is cleared. If override prevention is activated and ALL is appearing on the display, the machine lift and drive will be disabled until the override condition is cleared.
		<b>Cutout</b> LFT › Elvt Drv    On Dual Hght   Off Cancel	
	Elevated Drive <sup>(2)</sup>		This option is only available for machines equipped with an elevated drive prevention switch. If this option is activated, the machine will not operate if the platform is raised more than 80mm.
	Dual Height <sup>(3)</sup>	<b>Cutout</b> LFT Elvt Drv    Off › Dual Hght   On Cancel	This option is only available for machines fitted with the dual height feature.
Cancel <sup>(2, 3)</sup>		Select to exit the miscellaneous settings menu.	

JCB © CONNOR STANMORE - 13/03/2026 07:57.



Screen	Command	Graphic	Description
Calibration settings		<div style="border: 1px solid black; padding: 5px;"> <p>Cal Settings            › Cal Settings            Cal Status            Cancel</p> </div>	Use the lift mode button to move up and horn button to move down the menu, and drive mode button for enter.
	Cal Settings		Select to enter the calibration settings menu.
	Cal Status		Select to enter the calibration status menu.
	Cancel		Select to exit to Cal settings menu.
Calibration settings		<div style="border: 1px solid black; padding: 5px;"> <p>Cal Settings            › Enable      Off            Angle Sensor Off            NL Static    Off</p> <hr/> <p>› FL Static    Off            NL Dynamic Off            FL Dynamic Off            Cancel</p> </div>	Use the lift mode button to move up and horn button to move down the menu, and drive mode button for enter.
	Enable		After changing the value from the selected calibration, go to enable option and select to set the enable ON/OFF. Use turn left/turn right switch to change the value, and drive mode button for enter to start the calibration process.
	Angle Sensor		Select to set the angle sensor calibration ON/OFF. Use turn left/turn right switch to change value, and drive mode button for enter.
	NL Static		Select to set the no load static calibration ON/OFF. Use turn left/turn right switch to change value, and drive mode button for enter.
	FL Static		Select to set the full load static calibration ON/OFF. Use turn left/turn right switch to change value, and drive mode button for enter.
	NL Dynamic		Select to set the no load dynamic calibration ON/OFF. Use turn left/turn right switch to change value, and drive mode button for enter.
	FL Dynamic		Select to set the full load dynamic calibration ON/OFF. Use turn left/turn right switch to change value, and drive mode button for enter.
	Cancel		Select to exit the calibration settings main menu.

JCB © CONNOR STANMORE - 13/03/2026 07:57.



### 33 - Electrical System

24 - Instruments  
05 - Platform Controller

Screen	Command	Graphic	Description
Calibration status		<b>Cal Status</b> ›AS Complete Y NL Static Y FL Static Y	Use the lift mode button to move up and horn button to move down the menu, and drive mode button for enter.
	AS Complete		Shows the completion status of the angle sensor calibration.
	NL static	›NL Dynamic Y FL Dynamic Y PS Failure N AS Failure N	Shows the completion status of the no load static calibration.
	FL static		Shows the completion status of the full load static calibration.
	NL Dynamic		Shows the completion status of the no load dynamic calibration.
	FL Dynamic	<b>Data Change N</b> ›Cancel	Shows the completion status of the full load dynamic calibration.
	PS Failure		Shows the failure status of the pressure sensor.
	AS Failure		Shows the failure status of the angle sensor.
	Data Change		Select to accept the updated calibration data. Use turn left/turn right switch to change value, and drive mode button for enter.
	Cancel		Select to exit the calibration status main menu.
Height mode		<b>Height Mode</b> ›DD Height 1.16m DL Height 0.50m Cancel	Use the lift mode button to move up and horn button to move down the menu, and drive mode button for enter.
	DD height		Select to set the DD height. Use turn left/turn right switch to increase/decrease value, and drive mode button for enter.
	DL height		Select to set the DL height. Use turn left/turn right switch to increase/decrease value, and drive mode button for enter.
Service mode	Enable	<b>Service Mode</b> ›Enable Off	Select to enable the service mode ON/OFF. Use turn left/turn right switch to increase/decrease value, and drive mode button for enter.

JCB © CONNOR STANMORE - 13/03/2026 07:57.



Screen	Command	Graphic	Description
OPR Settings		<b>OPR Settings</b> › <b>Batt Alarm</b> <b>On</b> <b>Batt Del</b> <b>5min</b> <b>Brake Rel</b> <b>Off</b>	Use the lift mode button to move up and horn button to move down the menu, and drive mode button for enter.
	Battery Alarm		Select to set the low battery alarm ON/OFF. Use turn left/turn right switch to change the value, and drive mode button for enter.
	Battery Delay	<b>Idle Light</b> <b>On</b> <b>Motion Al</b> <b>On</b> › <b>Field Cal</b> <b>Cancel</b>	Select to set the battery alarm delay. Use turn left/turn right switch to increase/decrease value, and drive mode button for enter.
	Brake Release	<b>Idle Light</b> <b>On</b> <b>Motion Al</b> <b>On</b> <b>Field Cal</b> › <b>Rapid Cal</b> <b>Cancel</b>	Select to set the brake release ON/OFF. Use turn left/turn right switch to change the value, and drive mode button for enter.
	Idle Light		Select to set the idle lights ON/OFF. Use turn left/turn right switch to change the value, and drive mode button for enter.
	Motion Alarm	<b>SW Ver:00.00.XX</b>	Select to set the motion alarm ON/OFF. Use turn left/turn right switch to change the value, and drive mode button for enter.
	Field Cal <sup>(1)</sup>		Select to enter the field calibration menu.
	Rapid Cal <sup>(4)</sup>		Select to enter the rapid calibration menu.
	Cancel		Select to exit the OPR settings menu.
Field calibration		<b>Field Cal</b> › <b>Enable</b> <b>Off</b> <b>Angle Sensor</b> <b>Off</b> <b>NL Static</b> <b>Off</b>	Use the lift mode button to move up and horn button to move down the menu, and drive mode button for enter.
	Enable	› <b>NL Dynamic</b> <b>Off</b> <b>Cancel</b>	After changing the value from the selected calibration, go to enable option and select to set the enable ON/OFF. Use turn left/turn right switch to change the value, and drive mode button for enter to start the calibration process.
	Angle Sensor		Select to set the angle sensor calibration ON/OFF. Use turn left/turn right switch to change value, and drive mode button for enter.
	NL Static		Select to set the no load static calibration ON/OFF. Use turn left/turn right switch to change value, and drive mode button for enter.
	NL Dynamic		Select to set the no load dynamic calibration ON/OFF. Use turn left/turn right switch to change value, and drive mode button for enter.
	Cancel		Select to exit the field calibration menu.

JCB © CONNOR STANMORE - 13/03/2026 07:57.



Screen	Command	Graphic	Description
Rapid calibration			Use the lift mode button to move up and horn button to move down the menu, and drive mode button for enter.
	Enable		After changing the value from the selected calibration, go to enable option and select to set the enable ON/OFF. Use turn left/turn right switch to change the value, and drive mode button for enter to start the calibration process.
	Cancel		Select to exit the rapid calibration menu.
Fault history			Displays the list of errors generated.

- (1) Joystick firmware must be updated to version 00.00.26 or above to perform the field calibration.
- (2) Applicable for South-East Asia.
- (3) Applicable for North America and Canada.
- (4) Machine software must be version A115 or above and joystick firmware version 00.00.29 or above to perform rapid calibration.

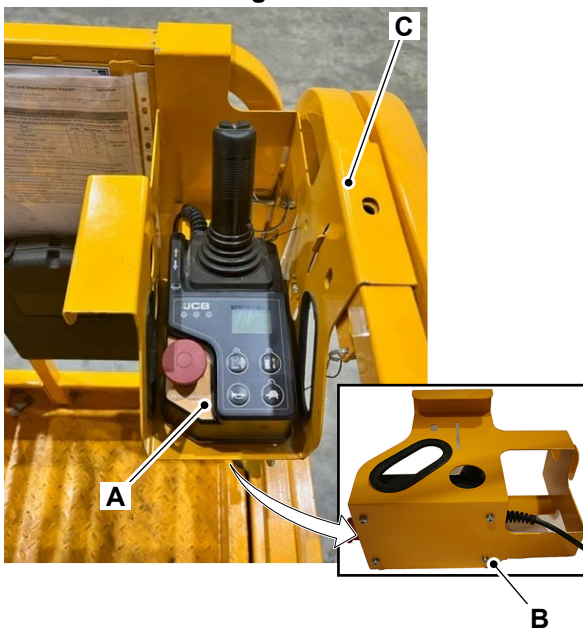
JCB © CONNOR STANMORE - 13/03/2026 07:57.

## Remove and Install

### Remove

1. Make the machine safe with the platform lowered.  
[Refer to: PIL 01-03-27.](#)
2. Make sure that the emergency stops are in OFF position.
3. Disconnect the battery quick disconnect handle.  
[Refer to: Disconnect and Connect \(PIL 33-05-00\).](#)
4. Disconnect the electrical connector from the platform control panel.
5. Remove the screws (x4).
6. Remove the platform control panel from the cradle.

**Figure 249.**



- A** Platform control panel
- B** Screws (x4)
- C** Cradle

### Install

1. The installation procedure is the opposite of the removal procedure.

## 36 - Horn

### 00 - General

Introduction .....	33-196
Technical Data .....	33-197
Check (Operation) .....	33-197
Remove and Install .....	33-198

### Introduction

**▲ WARNING** The horn is very loud. Any person nearby the machine must wear ear protection. If you do not wear ear protection your hearing may be permanently damaged.

The horn must be working correctly for safe machine operation.

The horn is activated at the platform control panel and sounds at the ground as a warning to ground personnel. An improperly functioning horn will prevent the operator from alerting the ground personnel of hazards or unsafe conditions.

Use the horn wherever necessary, but particularly at blind corners and when you are reversing the machine.

## Technical Data

**Table 96.**

Description	Data
Voltage	24V
Current	Less than 3A
Frequency (Low)	335 ± 20Hz
Frequency (High)	400 ± 20Hz
Sound level	105-118 dB

## Check (Operation)

1. Pull out the red 'Emergency Stop button' to the ON position at both the base and platform control panel and turn the ignition key to the ON position.
2. Push down the horn button at the platform control panel. The horn should sound.
3. If the horn fails to sound, investigate further. Check the fuse, check the wiring, make sure that the horn is repaired or replaced before the machine is used again.

## Remove and Install

For: S1932E EDRV [RAJ] ..... Page 33-198

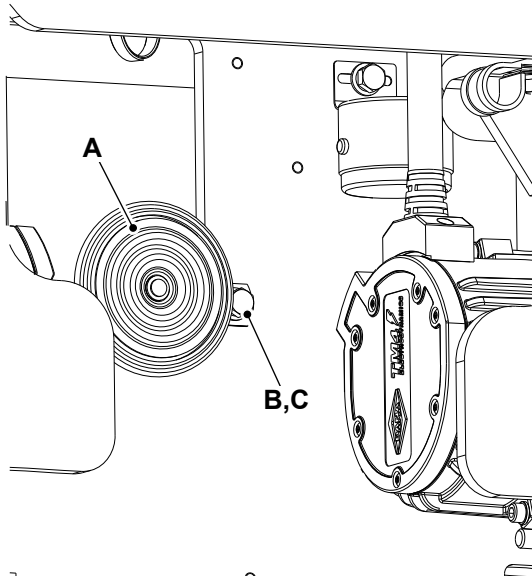
For: S2632E EDRV [RAJ], S2646E EDRV [RAJ], S3246E EDRV [RAJ], S4046E EDRV [RAJ], S4550E EDRV [RAJ] .... Page 33-198

(For: S1932E EDRV [RAJ])

### Remove

1. Make the machine safe.  
[Refer to: PIL 01-03-27.](#)
2. Disconnect the quick disconnect handle.  
[Refer to: Disconnect and Connect \(PIL 33-05-00\).](#)
3. Locate the horn behind the drive motors.
4. Disconnect the electrical connectors from the horn.
5. Remove the setscrew and washers.
6. Remove the horn from the machine.

**Figure 250.**



- A Horn
- B Setscrew
- C Washer

### Install

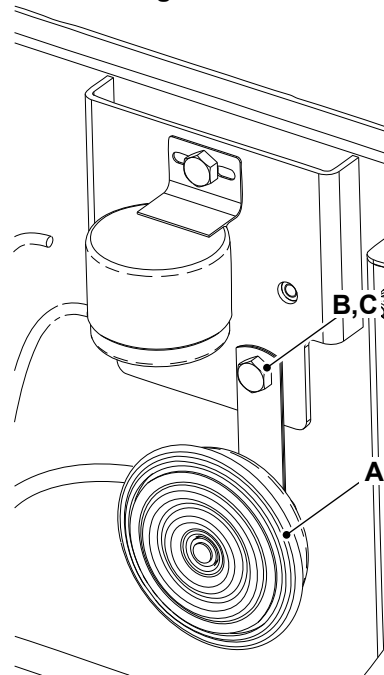
1. The installation procedure is the opposite of the removal procedure. Additionally do the following step.
2. Tighten the screw to the correct torque value.

(For: S2632E EDRV [RAJ], S2646E EDRV [RAJ], S3246E EDRV [RAJ], S4046E EDRV [RAJ], S4550E EDRV [RAJ])

### Remove

1. Make the machine safe.  
[Refer to: PIL 01-03-27.](#)
2. Disconnect the quick disconnect handle.  
[Refer to: Disconnect and Connect \(PIL 33-05-00\).](#)
3. Open the hydraulic compartment cover.  
[Refer to: Open and Close \(PIL 06-06-09\).](#)
4. Disconnect the electrical connectors from the horn.
5. Remove the setscrew and washers.
6. Remove the horn from the machine.

**Figure 251.**



- A Horn
- B Setscrew
- C Washer

### Install

1. The installation procedure is the opposite of the removal procedure. Additionally do the following step.
2. Tighten the screw to the correct torque value.



## 42 - Exterior Light

### 39 - Hazard Warning Light

Introduction .....	33-199
Remove and Install .....	33-200

### Introduction

The hazard warning lights are intermittent flashing indicator lights that flash in unison to warn surrounding personnel about the machine is in operation.

In normal machine operation the hazard warning lights will flash at a rate of 60 flashes per minute. If a fault condition occurs, the flash rate will increase to 120 flashes per minute.

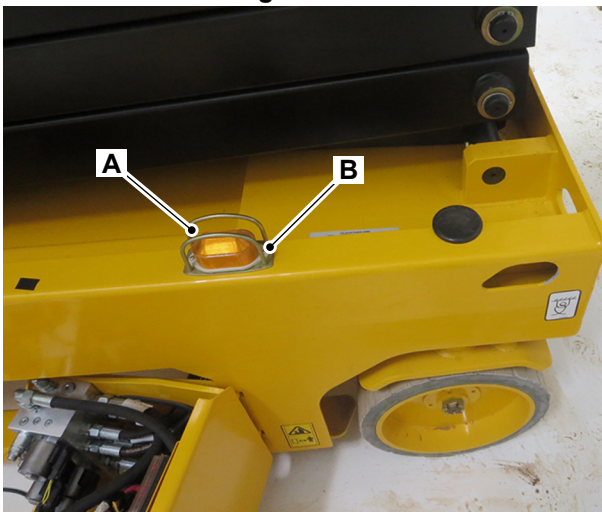
JCB © CONNOR STANMORE - 13/03/2026 07:57.

## Remove and Install

### Remove

1. Make the machine safe.  
[Refer to: PIL 01-03-27.](#)
2. Disconnect the battery quick disconnect handle.  
[Refer to: Disconnect and Connect \(PIL 33-05-00\).](#)
3. Remove the screw (x2).
4. Lift the light out of the aperture.
5. Disconnect the electrical connection from the warning light.
6. Remove the warning light away from the machine.

**Figure 252.**



- A** Warning light  
**B** Screw (x2)

### Install

1. The installation procedure is the opposite of the removal procedure.



## 45 - Control Module

### 03 - Machine Control

Introduction .....	33-201
Diagram .....	33-202

### Introduction

The MECU (Machine Electronic Control Unit) is located inside the hydraulic compartment.

The MECU receives inputs from various switches and sensors. The main function of the MECU is to control the safety and functionality of the machine.

Internal software data enables the MECU to process inputs and respond with the applicable outputs.

JCB © CONNOR STANMORE - 13/03/2026 07:57.

**Diagram****Table 97. PIN Definition**

<b>Pin</b>	<b>Customer I/O Name</b>	<b>Customer IO Type</b>
1	Ignition Supply	24V
2	Steer Right Solenoid	Digital Output Low Side
3	Raise Solenoid	Digital Output Low Side
4	EM Brake LH	Digital Output Low Side
5	EM Brake RH	Digital Output Low Side
6	DC Contactor Coil	Digital Output Low Side
7	Battery Ground	GND
8	Wheel Motor LH Temp Sensor	Analog Input
9	Lift Up Toggle Switch	Digital Input
10	Wheel motor LH Speed/Position Sensor	Analog Input
11	Wheel motor LH Speed/Position Sensor	Analog Input
12	Pothole Switch LH-RH Series	Digital Input
13	Solenoid Supply High Side	Solenoid High Side
14	Lower Limit Switch 2	Digital Input
15	Base Control - Key Switch	Digital Input
16	Lift Down Toggle Switch	Digital Input
17	Enable - Toggle Switch	Digital Input
18	Not Connected	Not Connected
19	Steer Left Solenoid	Digital Output Low Side
20	Lower Solenoid	Digital Output Low Side
21	Wheel Motor RH Temp Sensor	Analog Input
22	Lower Limit Switch 1	Digital Input
23	CAN (Controller Area Network) High	CAN High
24	Pressure Sensor 1	Analog Input
25	Pressure sensor 2	Analog Input
26	Wheel Motor Speed/Position Sensor supply	5V
27	Pothole Switch LH	Digital Input
28	Angle Sensor	Analog Input
29	Upper Limit Switch	Digital Input
30	Platform E-Stop Override	Digital Input
31	Wheel motor RH Speed/Position Sensor	Analog Input
32	Wheel motor RH Speed/Position Sensor	Analog Input
33	Pothole Switch RH	Digital Input
34	Not Connected	Not Connected
35	CAN Low	CAN Low

JCB © CONNOR STANMORE - 13/03/2026 07:57.



## 66 - Motor Controller

Introduction .....	33-203
Diagram .....	33-204
Clean .....	33-208
Remove and Install .....	33-208

## Introduction

The motor controller and inverter controls the speed of the electric motor and wheel drive motor connected to the hydraulic pump. The speed is determined by inputs from the Platform Control Unit.

The motor controller and inverter pump motor control module generates error codes which are monitored and displayed by the Platform Control Unit through the base display screens. Detailed fault code information can be found within the applicable HelpFiles located on JCB Service Pro and JCB ServiceMaster.

This is not a serviceable component. If the component is damaged, you must replace the complete unit.

JCB © CONNOR STANMORE - 13/03/2026 07:57.

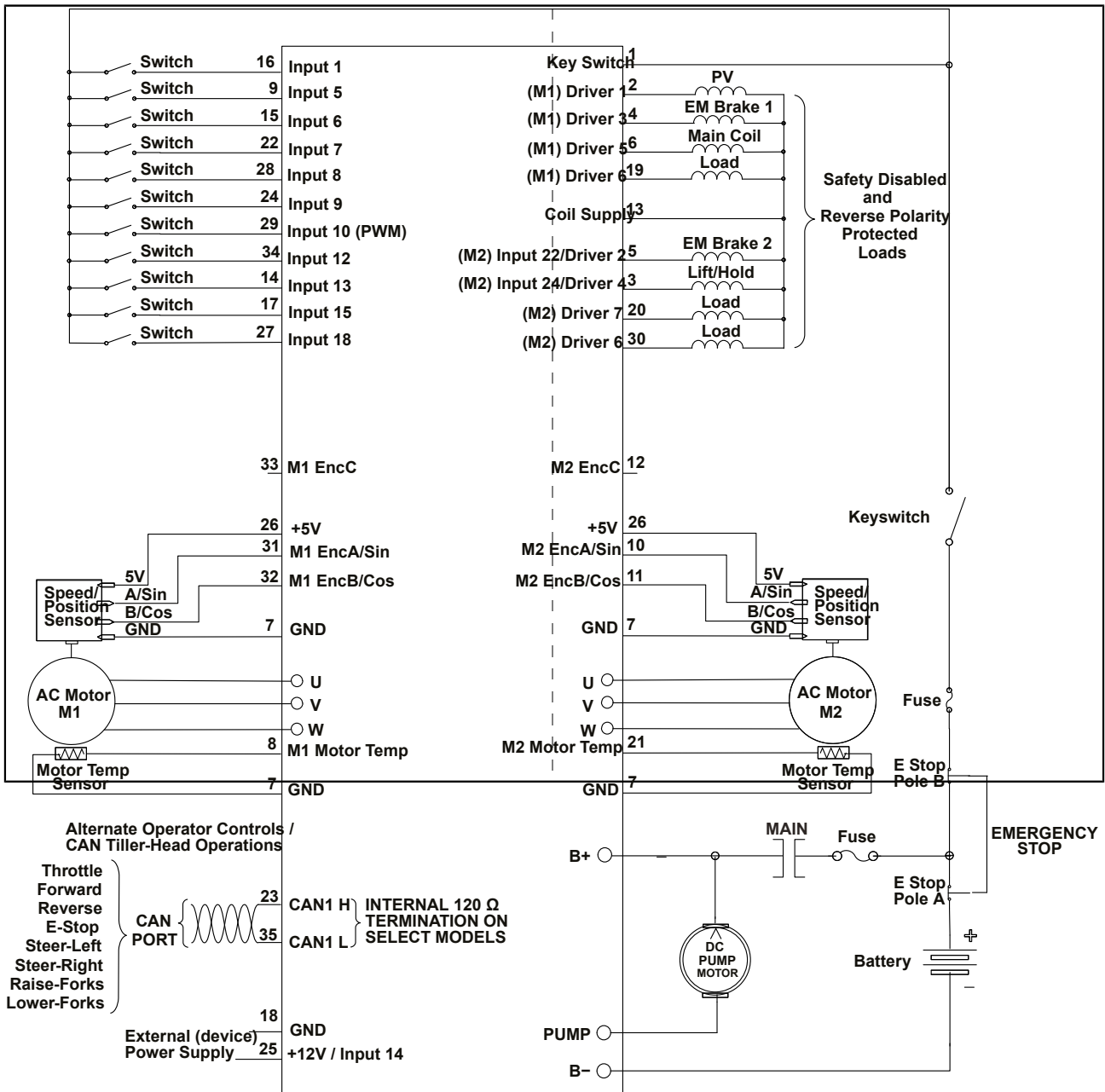


## Diagram

Figure 253. ....Page 33-205

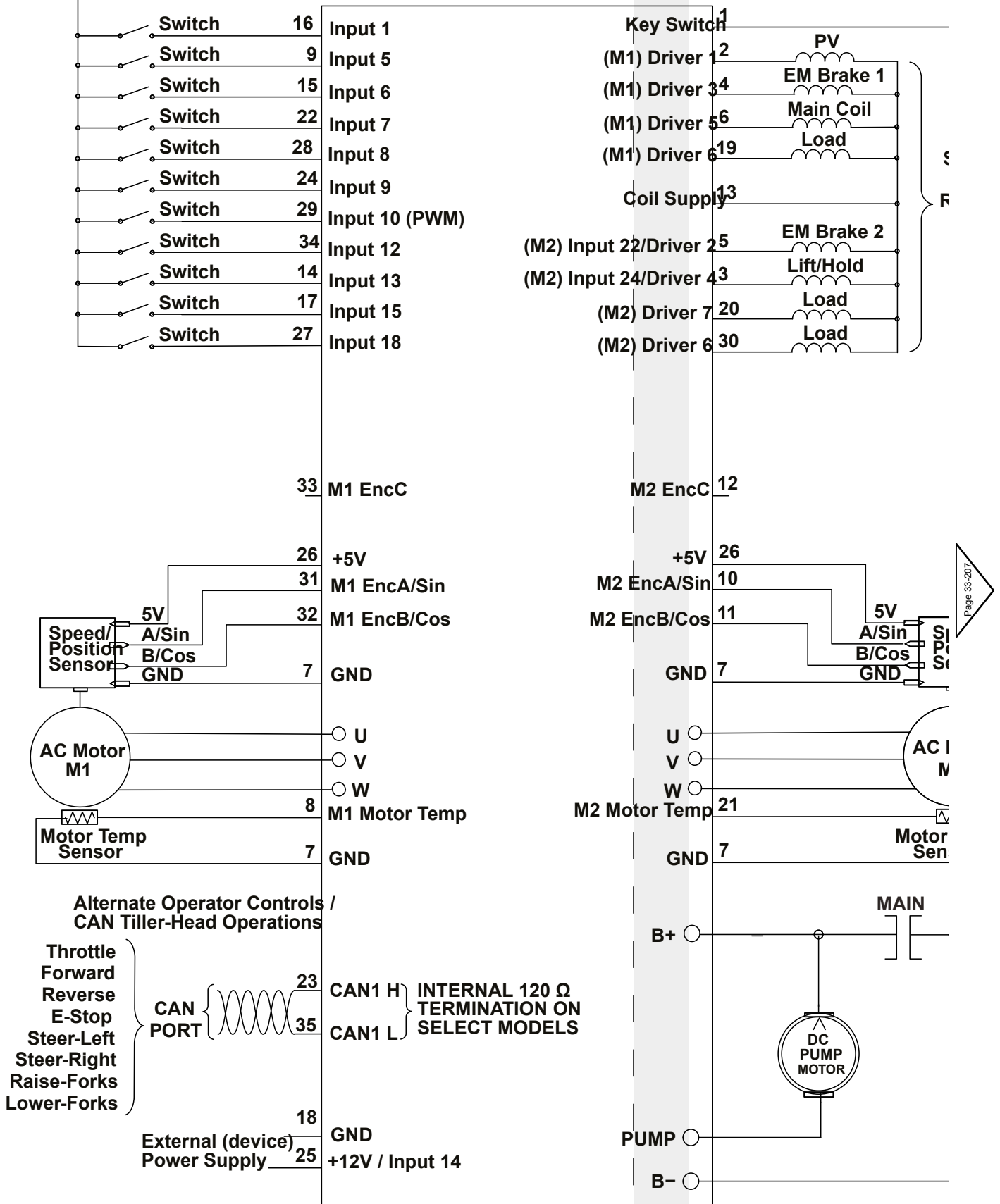
JCB © CONNOR STANMORE - 13/03/2026 07:57.

Figure 253.



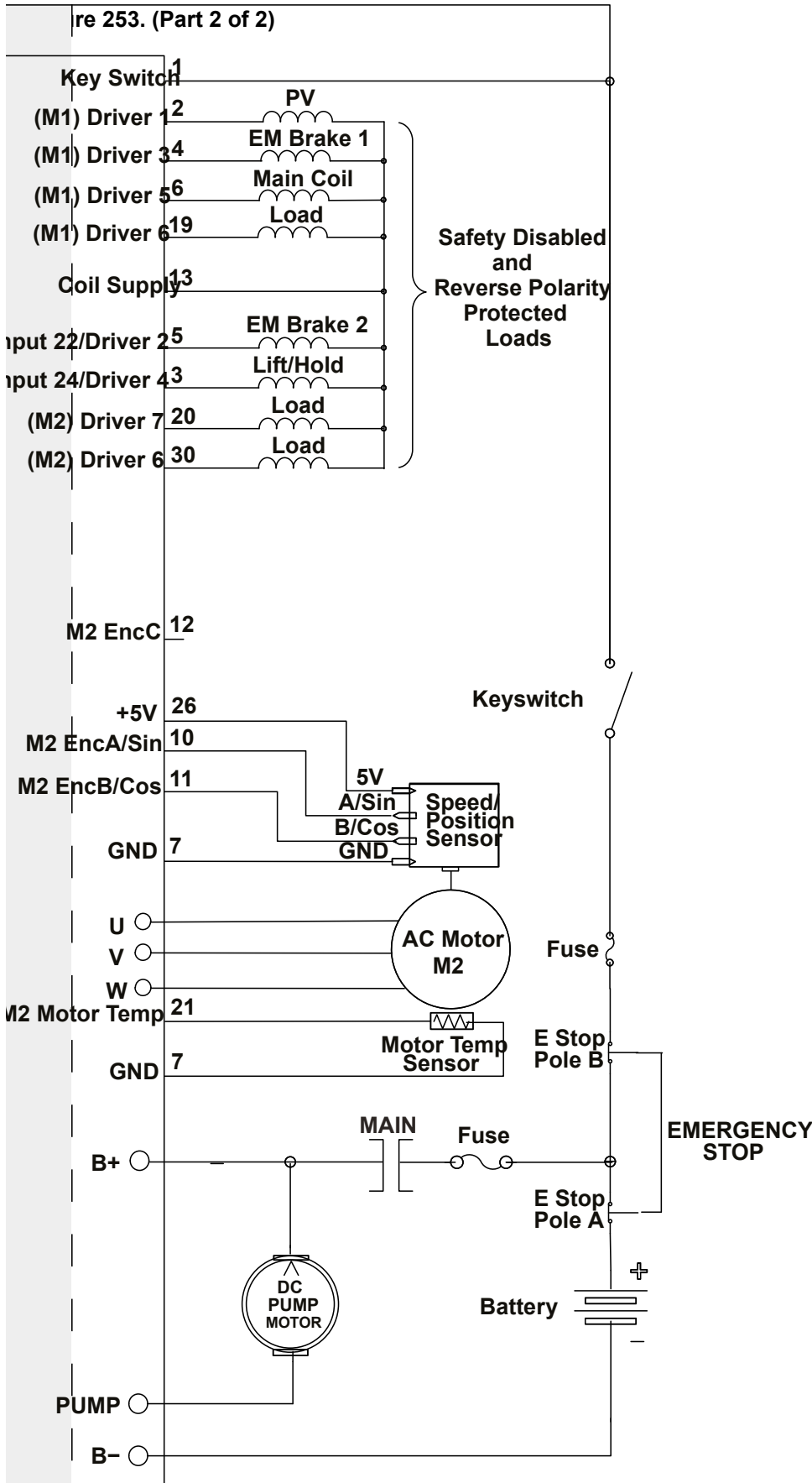
JCB © CONNOR STANMORE - 13/03/2026 07:57.

Figure 253. (Part 1 of 2)



Page 33-207

JCB © CONNOR STANMORE - 13/03/2026 07:57.



JCB © CONNOR STANMORE - 13/03/2026 07:57.

Page 33-206

## Clean

**▲ WARNING** You could get killed or injured if you touch the Battery positive and Battery negative terminals of the motor controller. The controller is installed with energy storing devices (capacitors). You must discharge the controller before you remove or install.

1. Obey all electrical system health and safety information.

[Refer to: Health and Safety \(PIL 33-00-00\).](#)

2. Make the machine safe.

[Refer to: PIL 01-03-27.](#)

3. Disconnect the quick disconnect handle.

[Refer to: Disconnect and Connect \(PIL 33-05-00\).](#)

4. Take care when handling the motor controller. The motor controller may contain a significant amount of stored electrical energy and could cause serious harm.

5. Remove any dirt or corrosion from the power and signal connector areas.

6. Clean the motor controller with a moist cloth.

7. Dry the motor controller before you connect the battery again.

8. Connect the quick disconnect handle.

[Refer to: Disconnect and Connect \(PIL 33-05-00\).](#)

## Remove and Install

**▲ WARNING** You could get killed or injured if you touch the Battery positive and Battery negative terminals of the motor controller. The controller is installed with energy storing devices (capacitors). You must discharge the controller before you remove or install.

This component is not serviceable, if it fails replace the complete unit.

### Remove

1. Obey all electrical system health and safety information.

[Refer to: Health and Safety \(PIL 33-00-00\).](#)

2. Make the machine safe.

[Refer to: PIL 01-03-27.](#)

3. Disconnect the quick disconnect handle.

[Refer to: Disconnect and Connect \(PIL 33-05-00\).](#)

4. Open the hydraulic compartment door.

[Refer to: Open and Close \(PIL 06-06-09\).](#)

5. Carefully disconnect the battery leads from the motor controller/inverter.

- 5.1. Disconnect the negative battery lead (Black) first.

- 5.2. Make sure you do not touch the battery positive pin and battery negative pin of the motor controller at the same time or you could be electrocuted.

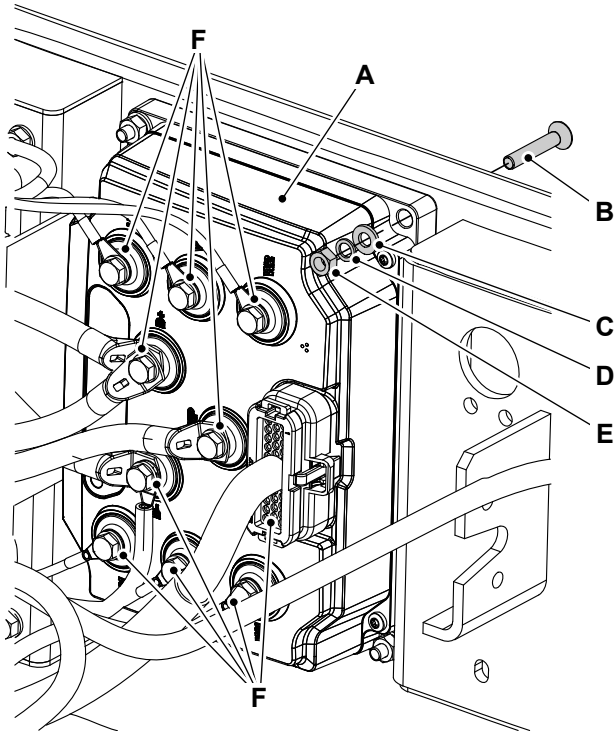
- 5.3. Disconnect the both motor (left and right) phase cables(U,V,W).

6. Disconnect the electrical connectors from the motor controller/inverter.

7. Remove the setscrews (x2), Washer (x2).

8. Remove the motor controller ECU (Electronic Control Unit) from the machine.

Figure 254.



- A Motor controller/Inverter
- B Setscrews (x4)
- C,D Washer (x4)
- E Nut (x4)
- F Electrical connectors

#### Install

1. The installation procedure is the opposite of the removal procedure.

## 57 - Electronic Diagnostic

### 03 - Servicemaster

Introduction .....	33-210
Operation .....	33-213

### Introduction

JCB Servicemaster is an application to allow engineers to diagnose and setup the various electronic control units within the JCB product range. The tools comprise of a front end generic user interface that allows the user to select the machine which they wish to work on as well as a number of various tools which allow:

- Programming electronic control units
- Diagnosing electronic issues
- Setup of various options
- Checking the service history of the machine.

JCB Servicemaster is updated on a monthly basis by incorporating Web Update. This is a program which works alongside Servicemaster to let the user know and allow them to download an update as and when it becomes available.

JCB Servicemaster software is for use with Microsoft Windows and a laptop personal computer. The laptop computer is connected to the machine diagnostic socket using special cables and an adaptor commonly referred to as DLA (Data Link Adaptor). A second generation DLA 2.0 has been launched and operates in essentially the same way as the original DLA. There are a couple of slight differences to the DLA 2.0. Refer to system information bulletin SI044 for more details.

Use Servicemaster software to:

- Display data from a machine ECU (Electronic Control Unit)
- Change data stored in a ECU

Servicemaster software communicates with the machine ECM (Engine Control Module) using the CAN (Controller Area Network)bus, refer to Control Modules (PIL 33-45).

### Diagnostics Tool - User Guide

#### Introduction

The diagnostics software tool is part of the JCB Servicemaster software suite. The diagnostics software is designed to be an easy to use fault finding tool.

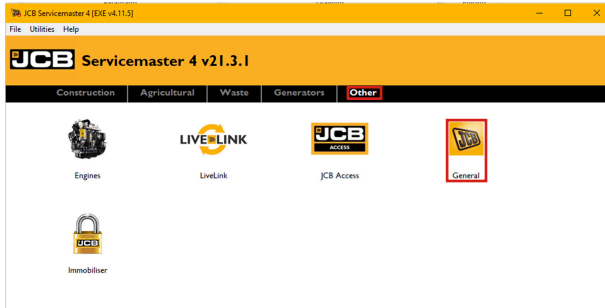
#### Connecting the Diagnostics

To use Diagnostics your laptop computer must be connected to the machine CAN bus.

### Starting the Diagnostics

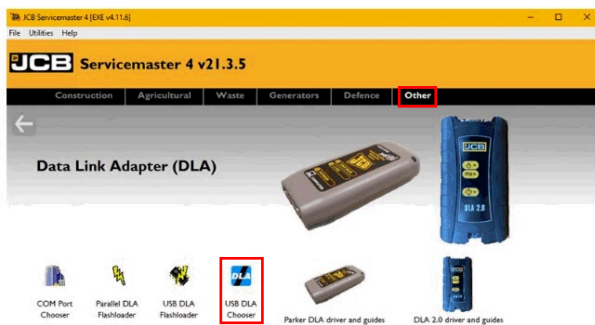
1. Turn ON the machine ignition.
2. Run JCB Servicemaster as administrator on the laptop computer.

**Figure 255.**



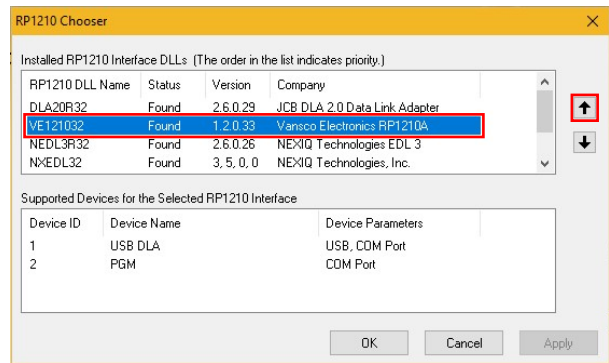
3. In Servicemaster go to “Other>General>DLA”.
  - 3.1. Left click on “USB DLA Chooser”.

**Figure 256.**



4. A new window will open. Refer to Figure 257.
  - 4.1. Make sure the sequence is correct based on the DLA you are using to plug in. The driver for the DLA in use should be on the top.
  - 4.2. Use arrows on the right side of the window to move the desired driver to move at the top.
  - 4.3. Click “Apply” and then click on “Ok”.

**Figure 257.**



### Flashloader Tool-User Guide

The Flashloader software tool is part of the JCB Servicemaster software suite. If the ECU is replaced and the data file in its flash memory is not applicable it will be necessary to flash the ECU memory with the correct data file. The Flashloader software tool can be used to access the data file name currently loaded in the ECU memory and is necessary upload a new data file to the ECU.

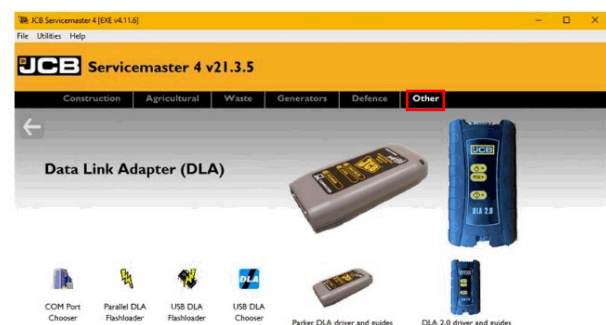
### Connecting Flash Loader

To use Flashloader your laptop computer must be connected to the machine CANbus.

### Starting Flashloader

1. Turn ON the machine ignition but DO NOT start the engine.
2. Start JCB Servicemaster on the laptop computer.

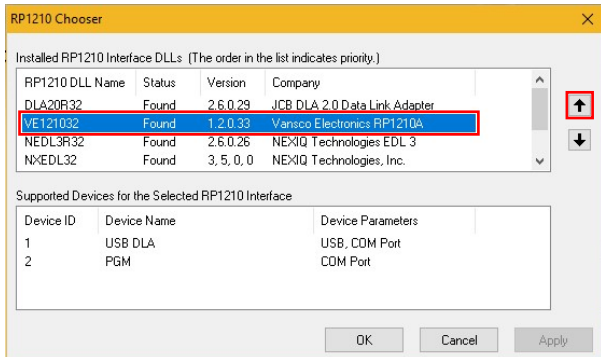
**Figure 258.**



3. Make sure that the correct DLA is selected in the chooser. Go to Other>General>DLA>USB DLA Chooser. The DLA Chooser window opens. Make sure the sequence is correct based on the DLA you are using to plug in. The driver for the DLA in use should be on the top. Use arrows on the right side of the window to move the desired driver to move at the top.

- Click "Apply" and then click on "Ok". Refer to Figure 259.

**Figure 259.**



**Using Flashloader**

Important: Do not turn off the ignition or isolate the system by accidentally engaging the operators seat isolation switch when using the flashloader. This will interrupt the flash signal to the ECU and will irreparably damage the ECU.

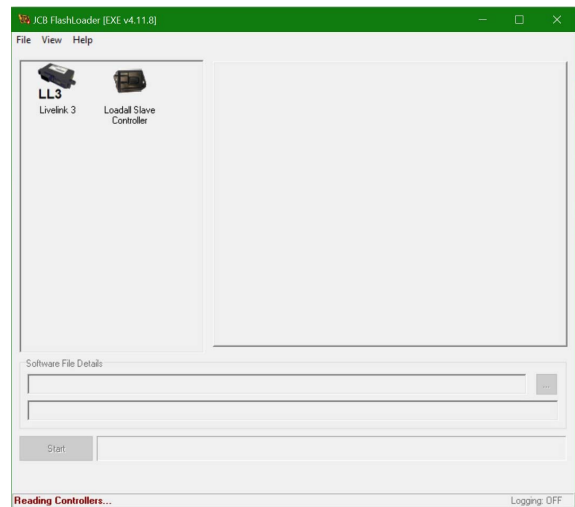
- Make sure that the machine ignition switch is set to ON but do not start the engine.
- Click on the flashloader icon. Refer to Figure 260.

**Figure 260.**



- Click on the ECU icon.
- Click on the Browse button and select the correct data file. Click Open.

**Figure 261. Typical**



- Click on the Start button. A confirmation window will appear. Click on the Yes to start the reprogramming of the ECU. The progress bar is displayed.
- When the programming is complete, switch the machine ignition to the OFF position.
- Before starting the machine make sure that the machine setup data is correct. You must check that all other relevant machine settings are correctly configured. Use the setup software tool.

## Operation

### Special Tools

Description	Part No.	Qty.
Data Link Adaptor (DLA 2.0) Kit	728/H5409	1

1. Connect DLA to diagnostic connector in RH door and open service master & click JCB access.

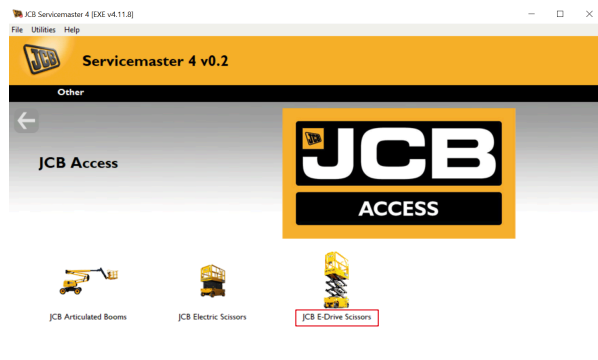
Special Tool: Data Link Adaptor (DLA 2.0) Kit (Qty.: 1)

**Figure 262.**



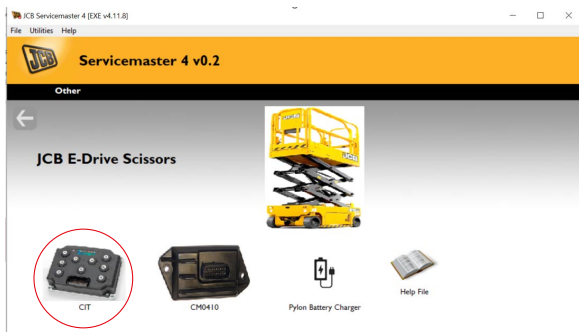
2. Click on JCB E-Drive Scissor.

**Figure 263.**



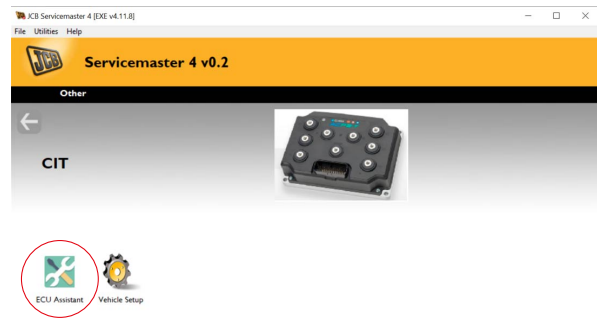
3. Click on CIT.

**Figure 264.**



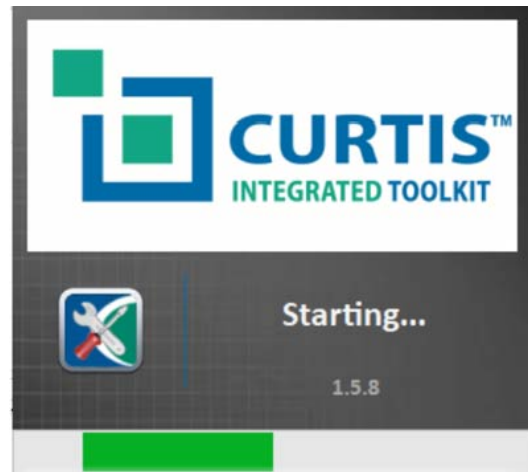
4. Click on ECU assistant.

**Figure 265.**



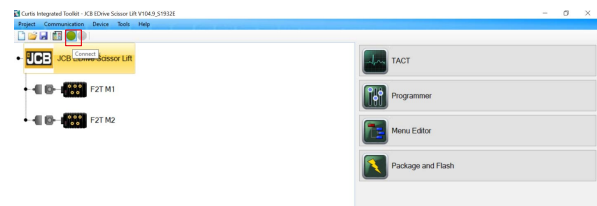
5. Wait for Curtis Integrated tool to open.

**Figure 266.**



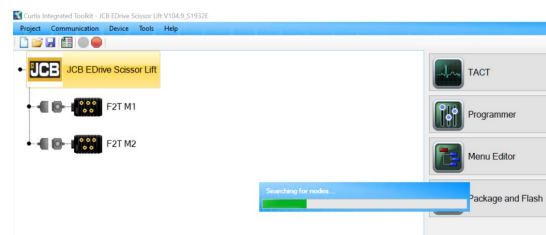
6. Click on green button to connect.

**Figure 267.**



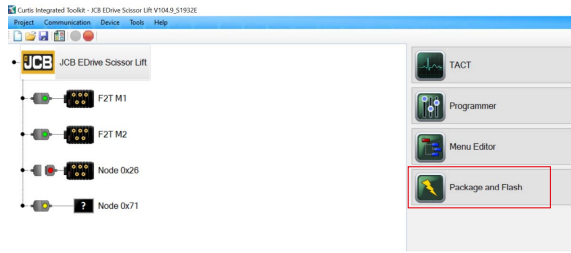
7. Wait for CIT to connect.

**Figure 268.**



8. Once online, click on package and flash.

**Figure 269.**



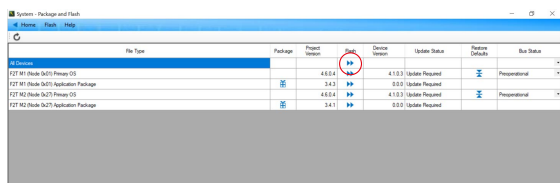
9. Wait for package and flash to open.

**Figure 270.**



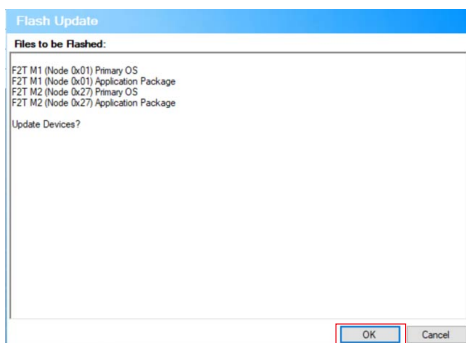
10. Click on blue arrow at the top.

**Figure 271.**



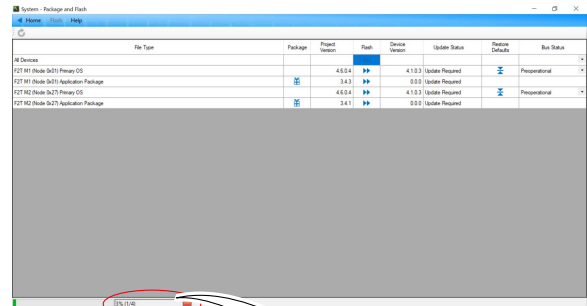
11. Click OK.

**Figure 272.**



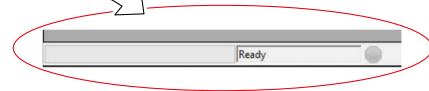
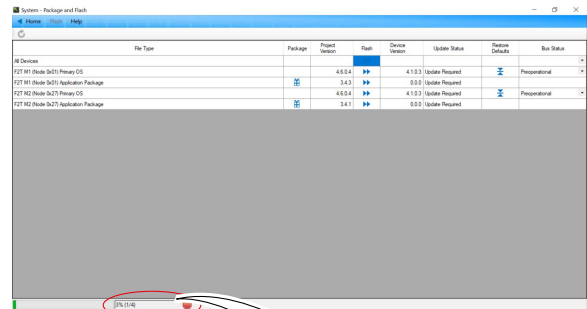
12. Wait for software to flash.

**Figure 273.**



13. One the status changes to ready, key cycle the machine and disconnect the DLA.

**Figure 274.**



## 90 - Error Codes

### Introduction

This machine has two display screens to display the fault codes.

- MECU (Machine Electronic Control Unit), installed in the hydraulic compartment.  
[Refer to: PIL 33-45-03.](#)
- Platform ECU (Electronic Control Unit) part of platform control panel, installed on the platform.  
[Refer to: PIL 33-24-05.](#)

## 84 - Sensor

### 00 - General

Introduction .....	33-216
Component Identification .....	33-217

### Introduction

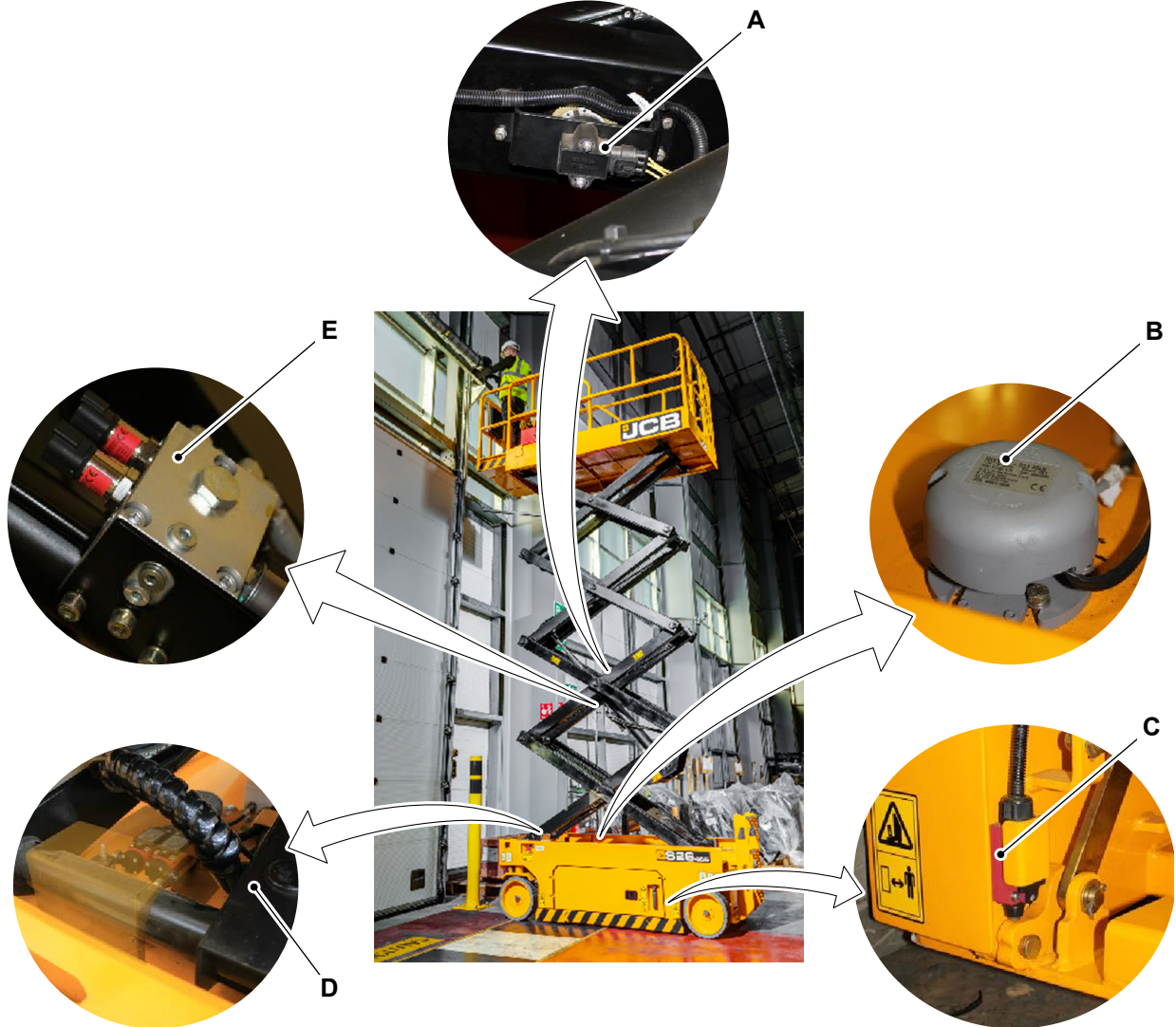
There are various sensors installed on the machine that control different functions.

The sensors are factory set and should not need adjustment, if however there is a fault (alarm or horn sounds) or if a new component is installed, the sensors may need calibrating, follow the calibration procedures in this manual to adjust the sensors to the correct settings.

The sensors are not serviceable, therefore they must be replaced in the event of damage.

### Component Identification

Figure 275.



- A Angle sensor
- C Pothole protection switches (x2)
- E Pressure sensor (x2)

- B Tilt sensor
- D Platform Limit switches (x2)



## 07 - Hydraulic Pressure

Introduction .....	33-218
Check (Operation) .....	33-219
Remove and Install .....	33-219

## Introduction

This machine is installed with the two hydraulic pressure sensors. They are mounted to a manifold block on the lift arm cylinder ram.

The hydraulic pressure sensors measure the cylinder head side pressure and send a signal to the MECU (Machine Electronic Control Unit) for the overload system.

JCB © CONNOR STANMORE - 13/03/2026 07:57.

## Check (Operation)

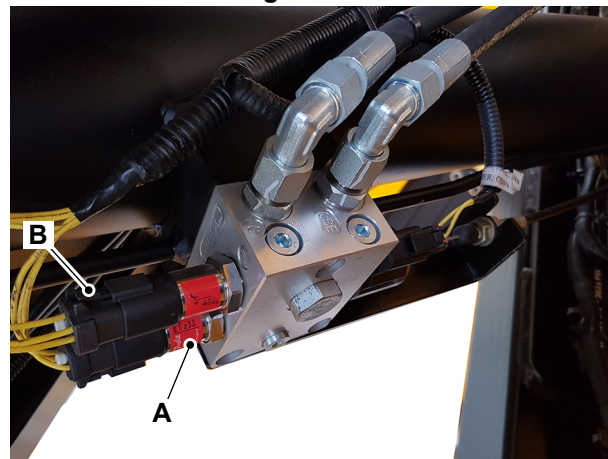
1. Make the machine safe.  
Refer to: [PIL 01-03-27](#).
2. Add the specified rated load to the platform.  
Percentage: 105%  
Refer to: [PIL 01-48](#).
3. Make sure that warning alarm sounds.

## Remove and Install

### Remove

1. Make the machine safe with the platform raised.  
Refer to: [PIL 01-03-27](#).
2. Install the safety strut. Danger or injury will result if the scissor arm is not supported fully.  
Refer to: [PIL 01-03-27](#).
3. Disconnect the battery quick disconnect handle.  
Refer to: [Disconnect and Connect \(PIL 33-05-00\)](#).
4. Disconnect the electrical connector from the pressure sensor.
5. Remove the sensor from the lift cylinder control valve.

**Figure 276.**



- A** Pressure sensor  
**B** Electrical connector

### Install

1. The installation procedure is the opposite of the removal procedure. Additionally do the following steps.
2. Tighten the pressure sensors to the correct torque value.
3. Make sure that the connectors are dry and free from hydraulic oil.
4. Make sure that all the connectors are correctly connected.



## 60 - Tilt

Introduction ..... 33-220  
Calibrate ..... 33-221  
Remove and Install ..... 33-221

## Introduction

The machine is installed with a tilt sensor. It is mounted directly to the chassis.

The tilt sensor measures the chassis angle from the horizontal position.

The tilt sensor sends a signal (24V) to the MECU (Machine Electronic Control Unit) if the chassis is within the safe level (below 3° front-to-back and below 1.5° side-to-side). If the chassis is over the safe tilt limit, the sensor sends a signal to the MECU and the warning light is lit at the platform ECU (Electronic Control Unit).

JCB © CONNOR STANMORE - 13/03/2026 07:57.

### Calibrate

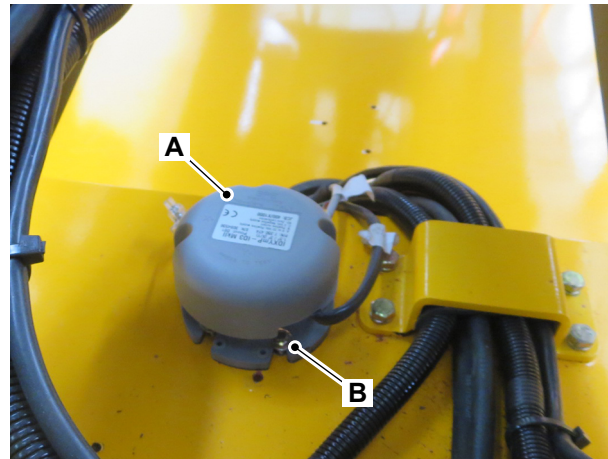
For 'Tilt Sensor Check',  
[Refer to: Calibrate \(PIL 01-12-00\).](#)

### Remove and Install

#### Remove

1. Make the machine safe with the platform raised.  
[Refer to: PIL 01-03-27.](#)
2. Install the safety strut. Danger or injury will result if the scissor arm is not supported fully.  
[Refer to: PIL 01-03-27.](#)
3. Disconnect the battery quick disconnect handle.  
[Refer to: Disconnect and Connect \(PIL 33-05-00\).](#)
4. Disconnect the electrical connector from the tilt sensor.
5. Remove the screws (x3).
6. Remove the tilt sensor from the machine.

**Figure 277.**



- A** Tilt sensor
- B** Screws (x3)

#### Install

1. The installation procedure is the opposite of the removal procedure.
2. Calibrate the tilt sensor.  
[Refer to: Calibrate \(PIL 33-84-60\).](#)



## 63 - Angle

Introduction ..... 33-222  
 Calibrate ..... 33-223  
 Remove and Install ..... 33-223

## Introduction

For: S1932E EDRV [RAJ] ..... Page 33-222  
 For: S2632E EDRV [RAJ], S2646E EDRV [RAJ], S3246E EDRV [RAJ], S4046E EDRV [RAJ], S4550E EDRV [RAJ] .... Page 33-222

### (For: S1932E EDRV [RAJ])

The angle sensor for this machine is mounted to the chassis on a bracket against the front fixed scissor pin.

The angle sensor measures the scissor pack angle continuously. It sends a signal to the MECU (Machine Electronic Control Unit) to determine the platform height. This signal is used for the overload system, downward stop height and diagnostics of the down limit switch.

### (For: S2632E EDRV [RAJ], S2646E EDRV [RAJ], S3246E EDRV [RAJ], S4046E EDRV [RAJ], S4550E EDRV [RAJ])

The angle sensor for this machine is mounted to the inner scissor boom on the centre pin.

The angle sensor measures the scissor arm assembly angle continuously. It sends a signal to the MECU to determine the platform height. This signal is used for the overload system, downward stop height and diagnostics of the down limit switch.

JCB © CONNOR STANMORE - 13/03/2026 07:57.

## Calibrate

Refer to: Calibrate (PIL 01-12-00).

## Remove and Install

For: S1932E EDRV [RAJ] ..... Page 33-223

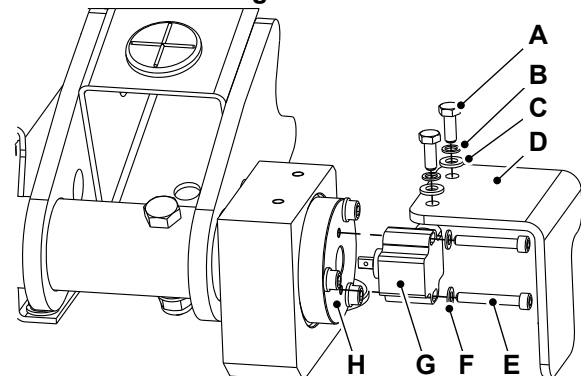
Otherwise ..... Page 33-224

(For: S1932E EDRV [RAJ])

### Remove

1. Make the machine safe with the platform raised.  
Refer to: Introduction (PIL 01-03-27).
2. Install the maintenance strut. Danger or injury will result if the scissor arm is not supported fully.  
Refer to: Introduction (PIL 01-03-27).
3. Disconnect the battery quick disconnect handle.  
Refer to: Disconnect and Connect (PIL 33-05-00).
4. Disconnect the electrical connector from the angle sensor.
5. Remove the bolt 1 (x2), washer 1 (x2) and washer 2 (x2).
6. Remove the bracket.

**Figure 278.**



- A** Bolt 1 (x2)
- B** Washer 1 (x2)
- C** Washer 2 (x2)
- D** Bracket
- E** Bolt 2 (x2)
- F** Washer 3 (x2)
- G** Angle sensor
- H** Machined boss

- 6.1. Make a note that there is a machined boss installed in the pivot pin and the angle sensor is housed within this machined boss.
7. Remove the bolt 2 (x2) and washer 3 (x2).
8. Remove the angle sensor from the machined boss.

#### Install

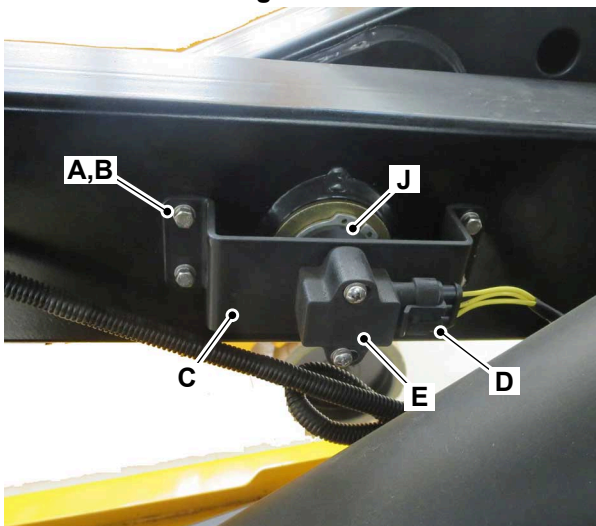
1. The installation procedure is the opposite of the removal procedure.
2. Calibrate the angle sensor.  
[Refer to: Calibrate \(PIL 33-84-63\).](#)
3. Calibrate the overload system.  
[Refer to: Calibrate \(PIL 01-12-00\).](#)

(Otherwise)

#### Remove

1. Make the machine safe with the platform raised.  
[Refer to: Introduction \(PIL 01-03-27\).](#)
2. Install the safety strut. Danger or injury will result if the scissor arm is not supported fully.  
[Refer to: Introduction \(PIL 01-03-27\).](#)
3. Disconnect the battery quick disconnect handle.  
[Refer to: Disconnect and Connect \(PIL 33-05-00\).](#)
4. Disconnect the electrical connector from the angle sensor.
5. Remove the bolt 1 (x4) and washer 1 (x4).
6. Remove the angle sensor with bracket from the scissor arm.

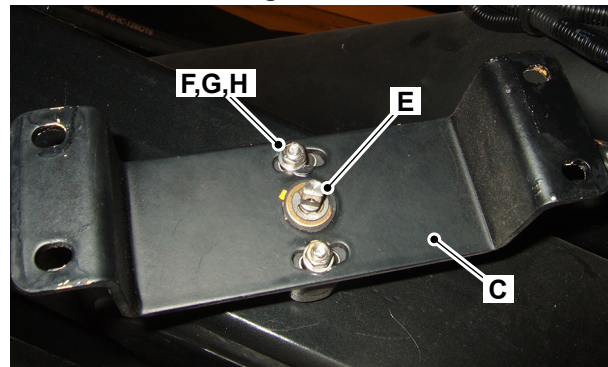
**Figure 279.**



- A Bolt 1 (x4)
- B Washer 1 (x4)
- C Bracket
- D Electrical connector
- E Angle sensor
- J Machined boss

- 6.1. Make a note that there is a machined boss installed in the pivot pin and the angle sensor is housed within this machined boss.
7. Remove the bolt 2 (x2), washer 2 (x2) and nut (x2).
8. Remove the angle sensor from the bracket.

**Figure 280.**



- C Bracket
- E Angle sensor
- F Bolt (x2)
- G Washer 2 (x2)
- H Nut (x2)

#### Install

1. The installation procedure is the opposite of the removal procedure.
2. Calibrate the angle sensor.  
[Refer to: Calibrate \(PIL 33-84-63\).](#)
3. Calibrate the overload system.  
[Refer to: Calibrate \(PIL 01-12-00\).](#)



## 82 - Pothole Protection System

Introduction .....	33-225
Calibrate .....	33-226
Remove and Install .....	33-227

## Introduction

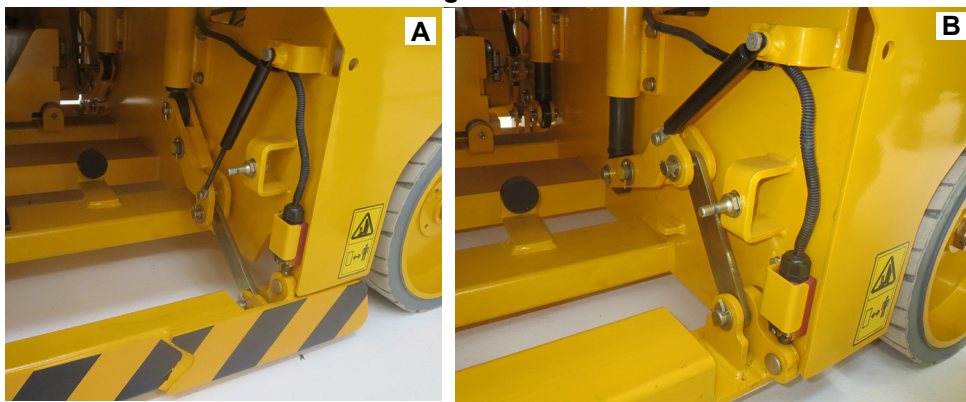
The pothole protection limit switch is located on both the pothole protection plates. This detects when the pothole protection plate is fully extended and sends a signal to the MECU (Machine Electronic Control Unit). This signal is used by MECU to determine if the plates are deployed correctly.

JCB © CONNOR STANMORE - 13/03/2026 07:57.

## Calibrate

1. Make the machine safe.  
[Refer to: Introduction \(PIL 01-03-27\).](#)
2. Check operation of the pothole protection system.  
[Refer to: Check \(Operation\) \(PIL 06-94-00\).](#)
3. If the pothole protection alarm is not triggered, do the following.
  - 3.1. Lower the platform.
  - 3.2. Check the pothole limit switches. Make sure that they are correctly pressed.
4. If one of the switches is not pressed when the plates are stowed, move the pothole limit switch closer to the plate.
  - 4.1. The pothole switches must be fully pressed in when the plates are stowed.
  - 4.2. The pothole switches must be fully relaxed out when the plates are deployed.

**Figure 281.**



**A** Pothole plate deployed / Pothole switch relaxed

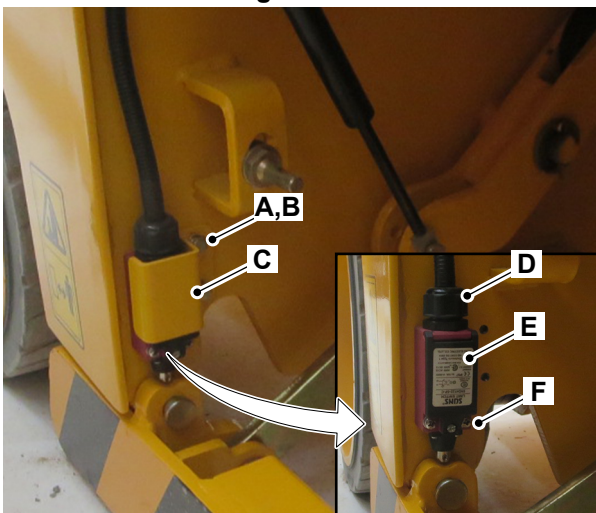
**B** Pothole plate stowed / Pothole switch pressed

## Remove and Install

### Remove

1. Make the machine safe with the platform lowered.  
 Refer to: [Introduction \(PIL 01-03-27\)](#).
2. Disconnect the battery quick disconnect handle.  
 Refer to: [Disconnect and Connect \(PIL 33-05-00\)](#).
3. Remove the bolt (x2) and washer (x2).
4. Remove the bracket.
5. Remove the screw (x2).
6. Disconnect the electrical connector.
7. Remove the switch from the machine.

**Figure 282.**

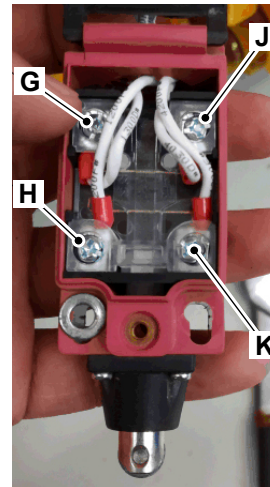


- A** Bolt (x2)
- B** Washer (x2)
- C** Bracket
- D** Electrical connector
- E** Switch
- F** Screw (x2)

### Install

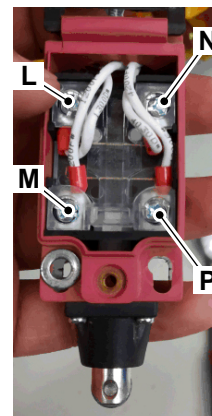
1. The installation procedure is the opposite of the removal procedure. Additionally do the following step.
2. Make sure that the wire connections installed at correct location.

**Figure 283. Pothole - Left side**



- G** Wire 1300D-21
- H** Wire 1200F-13
- J** Wire 4030D-22
- K** Wire 4200F-14

**Figure 284. Pothole - Right side**



- L** Wire 4030D-21
- M** Wire 1200F-13
- N** Wire 4300D-22
- P** Wire 4200F-14



## 84 - Platform Upper Limit

[Introduction](#) ..... 33-228  
[Calibrate](#) ..... 33-229  
[Remove and Install](#) ..... 33-229

## Introduction

The platform upper limit switch is located at the front fixed scissor pin on a cam/tab. This detects when the platform is fully raised and sends a signal to the MECU (Machine Electronic Control Unit). This limits the platform elevation.

JCB © CONNOR STANMORE - 13/03/2026 07:57.

## Calibrate

For 'Platform Upper Limit Height Setting',  
[Refer to: Calibrate \(PIL 01-12-00\)](#).

## Remove and Install

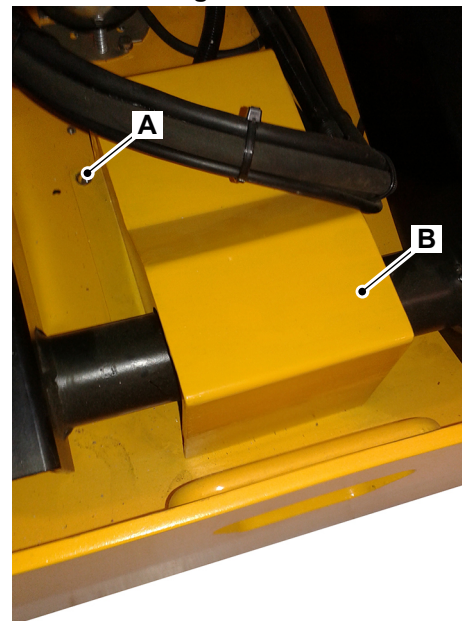
### Consumables

Description	Part No.	Size
Wiring Splice-Bootlace (1mm Red)	7205/0100	-

### Remove

1. Make the machine safe with the platform raised.  
[Refer to: Introduction \(PIL 01-03-27\)](#).
2. Install the safety strut. Danger or injury will result if the scissor arm is not supported fully.  
[Refer to: Introduction \(PIL 01-03-27\)](#).
3. Disconnect the battery quick disconnect handle.  
[Refer to: Disconnect and Connect \(PIL 33-05-00\)](#).
4. Remove the screw 1 (x4).
5. Remove the bracket to access the platform upper limit switch.

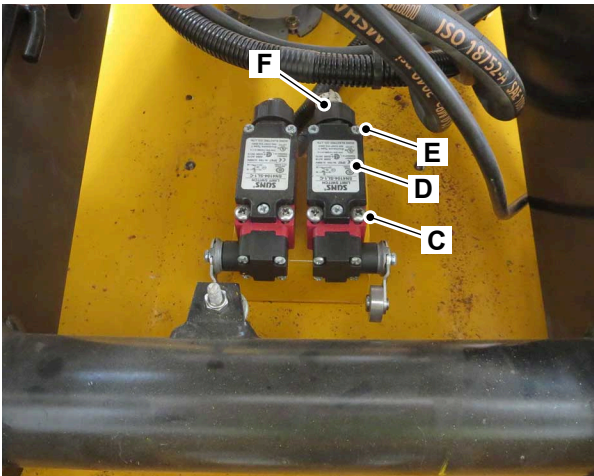
**Figure 285.**



- A** Screw 1 (x4)
- B** Bracket

6. Remove the screw 2 (x2).
7. Remove the platform upper limit switch from the machine.
8. Remove the screw 3 (x3).
9. Remove the cover plate.

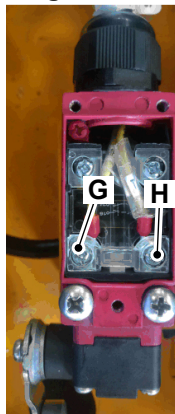
**Figure 286.**



- C** Screw 2 (x2)
- D** Cover plate
- E** Screw 3 (x3)
- F** Plastic cap

10. Loosen the screw 4 (x2).
11. Remove each wire from the terminal block.

**Figure 287.**



- G** Wire 4300B - Bottom right
- H** Wire 1300B - Bottom left

12. Loosen the plastic cap and pull out the wires from the platform upper limit switch.

#### Install

1. The installation procedure is the opposite of the removal procedure. Additionally do the following steps.
2. Make sure that the wire connections installed at correct location. [Refer to Figure 287.](#)
3. Before you connect the wires check the condition of the crimped terminals of the wires. If damaged, crimp the wire terminals with suitable bootlace ferrule tool.

[Consumable: Wiring Splice-Bootlace \(1mm Red\)](#)  
[Refer to: Repair \(PIL 33-12-00\).](#)

4. Make sure that the conduit on the harness is placed into the cap nut to make sure of correct sealing.
5. Make sure that when you install the bracket, you do not damage the harness.
6. Calibrate the platform upper limit switch.  
[Refer to: Calibrate \(PIL 33-84-84\).](#)



## 85 - Platform Down Limit

Introduction .....	33-231
Calibrate .....	33-232
Remove and Install .....	33-232

## Introduction

The platform down limit switch is located at the front fixed scissor pin on a cam/tab. This detects when the platform is close to stowed position and sends a signal to the MECU (Machine Electronic Control Unit).

The output of the down limit switch is used to detect when the platform is in a stowed or closed position. This output is used for the overload system, over tilt system and the elevated drive speed (reduced forward/reverse travel speed when the platform is raised).

JCB © CONNOR STANMORE - 13/03/2026 07:57.

## Calibrate

For 'Platform Down Limit Height Setting',  
[Refer to: Calibrate \(PIL 01-12-00\)](#).

## Remove and Install

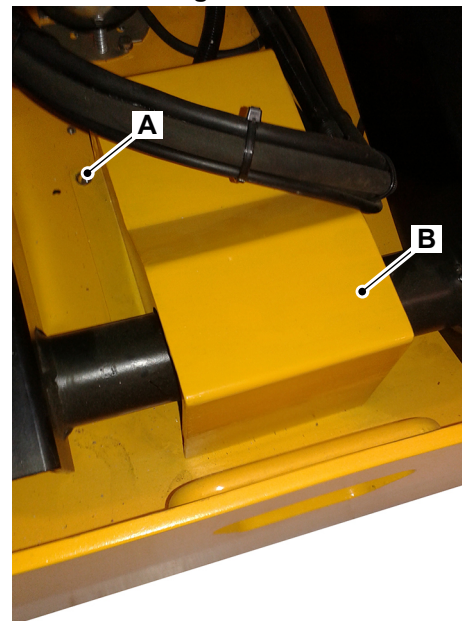
### Consumables

Description	Part No.	Size
Wiring Splice-Bootlace (1mm Red)	7205/0100	-

### Remove

1. Make the machine safe with the platform raised.  
[Refer to: Introduction \(PIL 01-03-27\)](#).
2. Install the safety strut. Danger or injury will result if the scissor arm is not supported fully.  
[Refer to: Introduction \(PIL 01-03-27\)](#).
3. Disconnect the battery quick disconnect handle.  
[Refer to: Disconnect and Connect \(PIL 33-05-00\)](#).
4. Remove the screw 1 (x4).
5. Remove the bracket to access the platform down limit switch.

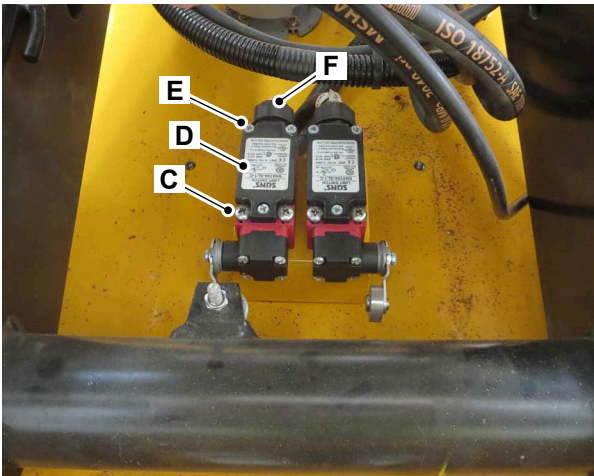
**Figure 288.**



- A** Screw 1 (x4)
- B** Bracket

6. Remove the screw 2 (x2).
7. Remove the platform down limit switch from the machine.
8. Remove the screw 3 (x3).
9. Remove the cover plate.

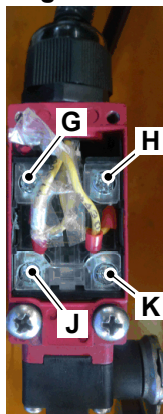
**Figure 289.**



- C** Screw 2 (x2)
- D** Cover plate
- E** Screw 3 (x3)
- F** Plastic cap

10. Loosen the screw 4 (x4).
11. Remove each wire from the terminal block.

**Figure 290.**



- G** Wire 4200A - 23
- H** Wire 1200A - 24
- J** Wire 1300A - 16
- K** Wire 4300A - 15

12. Loosen the plastic cap and remove the wires from the platform down limit switch.

#### Install

1. The installation procedure is the opposite of the removal procedure. Additionally do the following steps.
2. Make sure that the wire connections installed at correct location. [Refer to Figure 290.](#)
3. Before you connect the wires check the condition of the crimped terminals of the wires. If damaged, crimp the wire terminals with suitable bootlace ferrule tool.

[Consumable: Wiring Splice-Bootlace \(1mm Red\)](#)  
[Refer to: Repair \(PIL 33-12-00\).](#)

4. Make sure that the conduit on the harness is placed into the cap nut to make sure of correct sealing.
5. Make sure that when you install the bracket, you do not damage the harness.
6. Calibrate the platform down limit switch.  
[Refer to: Calibrate \(PIL 33-84-85\).](#)



## **86 - Solenoid**

### **00 - General**

[Introduction .....](#) [33-234](#)  
[Component Identification .....](#) [33-235](#)

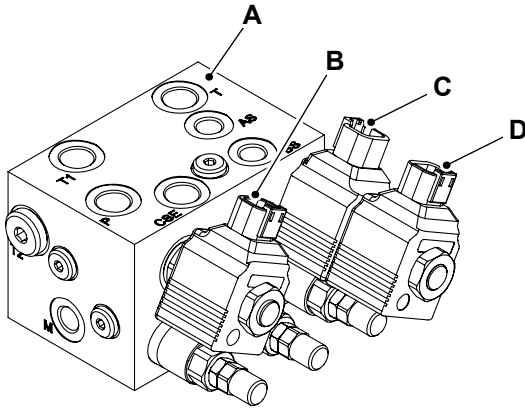
### **Introduction**

The solenoid valves are an integrated device containing an electromechanical solenoid which actuates a hydraulic valve, or a solenoid switch.

JCB © CONNOR STANMORE - 13/03/2026 07:57.

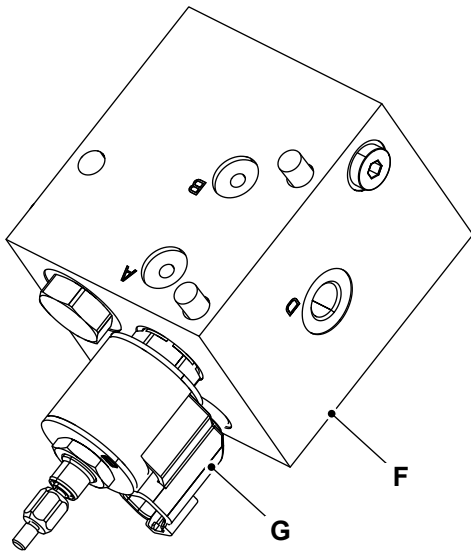
## Component Identification

**Figure 291. Main control valve block**



- A** Main control valve block
- B** Solenoid - Platform lifting solenoid
- C** Solenoid - Steering
- D** Solenoid - Steering

**Figure 292. Lift cylinder control valve**



- F** Lift cylinder control valve
- G** Lowering solenoid



## 95 - AC Circuit

### 09 - Residual Current Circuit Breaker with Overcurrent protection (RCBO)

Introduction .....	33-236
Check (Operation) .....	33-237
Remove and Install .....	33-237

### Introduction

#### RCBO (if fitted)

**▲ WARNING** Working with equipment that runs on Alternating Current (AC) could be dangerous. Any maintenance work on such equipment should be done by an authorised electrical engineer or a suitably trained person. All maintenance work must comply with IEC 60204-1 in Europe.

An RCBO (Residual Current Breaker with Over-Current) (or GFCI in North America) is a type of circuit breaker with two functions.

- To protect life.
- To protect an overload on the circuit (overcurrent and short circuit).

The RCBO has two circuits for detecting an imbalance and an overload but use the same interrupt method (breaker or trip).

JCB © CONNOR STANMORE - 13/03/2026 07:57.

## Check (Operation)

Make sure the RCBO (Residual Current Breaker with Over-Current) is checked in line with the maintenance schedules.

[Refer to: PIL 78-24-10.](#)

1. Make the machine safe with the platform raised.  
[Refer to: Introduction \(PIL 01-03-27\).](#)
2. Install the safety strut. Danger or injury will result if the scissor arm is not supported fully.  
[Refer to: Introduction \(PIL 01-03-27\).](#)
3. Connect the AC (Alternating Current) power source.
4. Press the test button on the RCBO.
  - 4.1. Make sure that the switch goes to the OFF position.

## Remove and Install

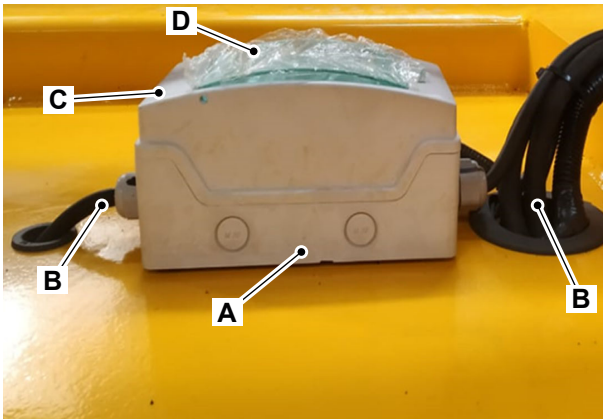
### Consumables

Description	Part No.	Size
Wiring Splice-Bootlace (2.5mm Grey)	7205/0250	-

**⚠ WARNING** Working with equipment that runs on Alternating Current (AC) could be dangerous. Any maintenance work on such equipment should be done by an authorised electrical engineer or a suitably trained person. All maintenance work must comply with IEC 60204-1 in Europe.

### Remove

1. Make the machine safe with the platform raised.  
[Refer to: Introduction \(PIL 01-03-27\).](#)
2. Install the safety strut. Danger or injury will result if the scissor arm is not supported fully.  
[Refer to: Introduction \(PIL 01-03-27\).](#)
3. Disconnect the battery quick disconnect handle.  
[Refer to: Disconnect and Connect \(PIL 33-05-00\).](#)
4. Disconnect the AC (Alternating Current) power source.
5. Open the guard cover. [Refer to Figure 293.](#)
6. Move the switch to the OFF position.
7. Remove the cover plate. [Refer to Figure 293.](#)
8. Remove the screws to disconnect the wires from the RCBO (Residual Current Breaker with Over-Current).
9. Remove the yellow tabs.
10. Remove the RCBO unit from the machine.

**Figure 293.**


- A RCBO unit
- B Cable wires Knob
- C Cover plate
- D Guard cover

### Install

1. The installation procedure is the opposite of the removal procedure. Additionally do the following steps.
2. Before you connect the wires check the condition of the crimped terminals of the wires. If damaged, crimp the wire terminals with suitable bootlace ferrule tool.

Consumable: [Wiring Splice-Bootlace \(2.5mm Grey\)](#)

[Refer to: Repair \(PIL 33-12-00\).](#)

3. Check the operation of the RCBO unit.

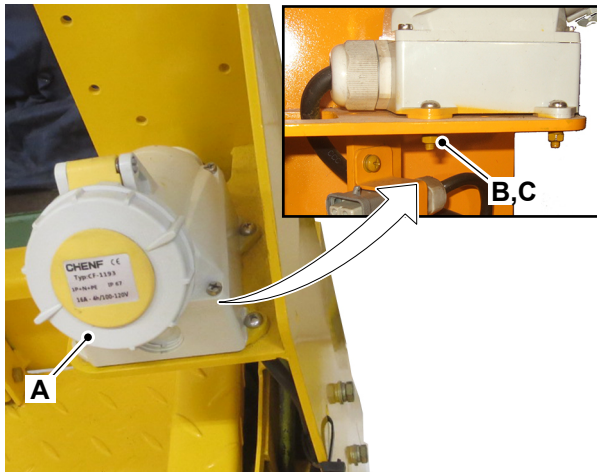
[Refer to: Check \(Operation\) \(PIL 33-95-09\).](#)

## 75 - AC Connector

### Remove and Install

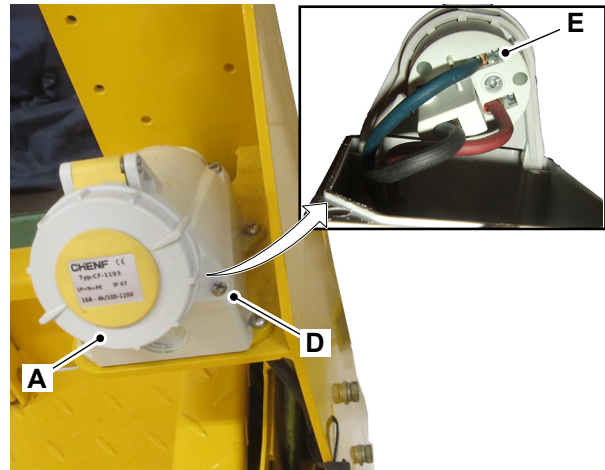
#### Remove

1. Make the machine safe with the platform lowered.  
[Refer to: Introduction \(PIL 01-03-27\).](#)
2. Disconnect the quick disconnect handle.  
[Refer to: Disconnect and Connect \(PIL 33-05-00\).](#)
3. Remove the screw 1 (x4) and nut 1 (x4).
4. Remove the AC (Alternating Current) connector assembly from the machine.

**Figure 294.**


- A** AC connector
- B** Screw 1 (x4)
- C** Nut 1 (x4)

5. Remove the screw (x4).
6. Disassemble the AC connector assembly.
7. Loosen the screw 3 (x3).
8. Remove the wires from the AC connector.

**Figure 295.**


- A** AC connector
- D** Screw 2 (x4)
- E** Screw 3 (x3)

- 8.1. Make a note that each wire terminal is installed with bootlace ferrules.

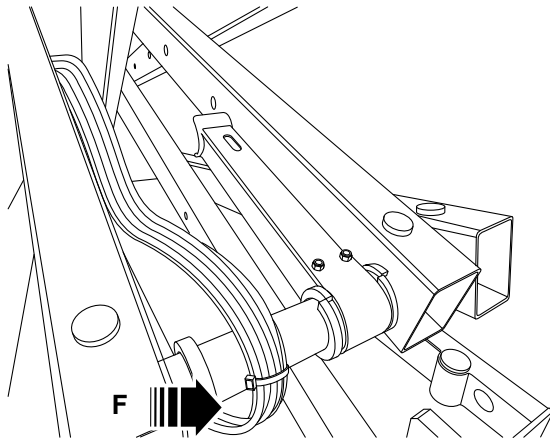
9. Raise the platform.
10. Install the maintenance strut. Danger or injury will result if the scissor arm is not supported fully.  
[Refer to: Introduction \(PIL 01-03-27\).](#)
11. Remove the cable ties from the scissor arm.
12. Disconnect the other end of wires from the RCBO (Residual Current Breaker with Over-Current) (if installed).  
[Refer to: Remove and Install \(PIL 33-95-09\).](#)
13. Remove the cable wire from the machine.

#### Install

1. The installation procedure is the opposite of the removal procedure. Additionally do the following steps.
2. Check the condition of the cables. If damaged, replace them.
3. Make a note that the AC cables should be separated as far from the DC (Direct Current) cables as possible.
4. When you route the cable wires on the scissor arm, make sure you keep the specified gap at each scissor arm pivot. Do not install the cables too tight.

Distance: 20mm

Figure 296.



F Gap (20mm)

JCB © CONNOR STANMORE - 13/03/2026 07:57.



---

# 72 - Fasteners and Fixings

Contents	Page No.
72-00 Fasteners and Fixings	
72-00-00 General .....	72-2
72-03 Screws	
72-03-00 General .....	72-4
72-06 Bolts	
72-06-00 General .....	72-6

## 00 - Fasteners and Fixings

### 00 - General

#### Introduction

#### JCB Fasteners (Before September 2017)

Some external fasteners on JCB machines are manufactured using an improved type of corrosion resistant finish. This type of finish is called Dacromet and replaces the original Zinc and Yellow Plating used on earlier machines. The two types of fasteners can be readily identified by colour and part number suffix. Refer to Table 1. Fastener Types.

**Table 98.**

Fastener Type	Colour	Part Number Suffix
Zinc and Yellow	Golden Finish	Z (e.g. 1315/3712Z)
Dacromet	Mottled Silver Finish	D (e.g. 1315/3712D)

Note: As the Dacromet fasteners have a lower torque setting than the Zinc and Yellow fasteners, the torque figures used must be relevant to the type of fastener.

A Dacromet bolt should not be used in conjunction with a Zinc or Yellow plated nut, as this could change the torque characteristics of the torque setting further. For the same reason, a Dacromet nut should not be used with a Zinc or Yellow plated bolt.

All bolts used on JCB machines are high tensile and must not be replaced by bolts of a lesser tensile specification.

Dacromet bolts, due to their high corrosion resistance are used in areas where rust could occur. Dacromet bolts are only used for external applications. They are not used in internal applications.

#### JCB Fasteners (After September 2017)

**Table 99.**

Fastener Type	Colour	Part Number Suffix
Zinc flake-silver	White aluminium (silver-grey), Dull	D (e.g. 1315/3712D)
Zinc and heavy trivalent passivated with seal	Silver (Bright iridescent)	V (e.g. 1315/3712V)

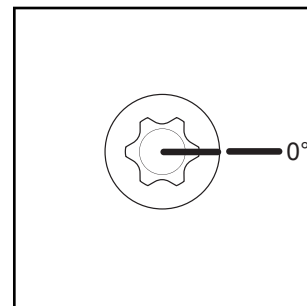
Fastener Type	Colour	Part Number Suffix
Zinc Nickel - silver/grey	Dark, dull silver grey	Not assigned
Zinc Nickel - black	Black, chalky texture	N (e.g. 1315/3712N)
Zinc flake - black	Black, slight gloss	B (e.g. 1315/3712B)

#### Tightening Method

The following example explains the recommended torque and angle procedure. A torque angle gauge should be used for accuracy, but as a visual check, the bolts can be match marked as described below.

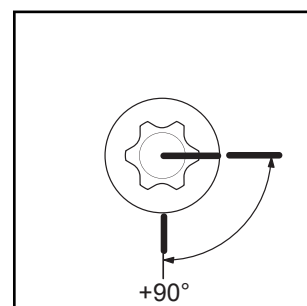
1. Tighten the bolt to the specified torque (specified torque values will be detailed in the relevant PIL sections).
2. Mark a line across the centre of the bolt, and a second line on the part to be clamped - the two lines should be aligned. Refer to Figure 297.

**Figure 297.**



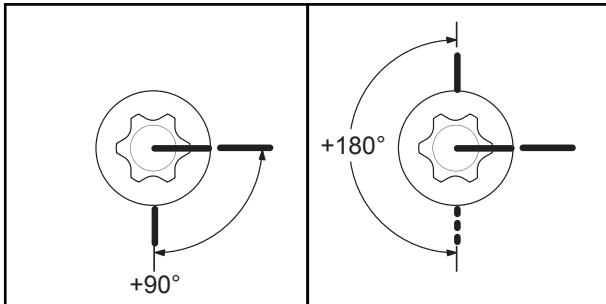
3. Mark a third line at the specified torque angle - in this instance the additional torque angle is 90°. This line must be marked the specified angle in a clockwise direction (to further tighten the bolt). Refer to Figure 298.

**Figure 298.**



4. In some instances, angle torque tightening can be specified in two stages, for instance in this example, the first angle quoted is  $90^\circ$  and then a second angle of  $180^\circ$ . The additional  $180^\circ$  angle is from the LAST tightened position. Refer to [Figure 299](#).

**Figure 299.**



5. Tighten the bolt so that the line on the bolt aligns with the angle(s) marked on the item to be clamped - remember, to ensure complete accuracy an angle gauge should be used.

## 03 - Screws

### 00 - General

Introduction ..... 72-4  
 Technical Data ..... 72-5

### Introduction

Use the torque setting tables (Technical Data) only where no torque setting is specified in the text. Note: Dacromet fasteners are lubricated as part of the plating process, do not lubricate. Torque settings are given for the following conditions:

**Table 100. Up to September 2017**

Type	Condition 1	Condition 2
no coating	Unlubricated fasteners	Zinc flake silver (Dacromet) fasteners.
2 (obsolete from September 2017).	Zinc fasteners	Lubricated zinc and yellow plated fasteners.
3, 4 (obsolete from September 2017).	Yellow plated fasteners	Where there is a natural lubrication. For example, cast iron components.

**Table 101. From September 2017**

Type (suffix)	Condition 1	Condition 2
no coating	Unlubricated fasteners	Where there is a natural lubrication. For example, cast iron components
1 (D)		Zinc flake silver (Dacromet, Geomet) fasteners.
5 (V or Z)		Zinc and heavy trivalent with seal
7 (G) <sup>(1)</sup>		Zinc nickel - silver
8 (N) <sup>(1)</sup>		Zinc nickel - black
9 (B) <sup>(1)</sup>		Zinc flake - black

(1) With integrated torque control lubricant.

JCB © CONNOR STANMORE - 13/03/2026 07:57.

## Technical Data

**Table 102. Torque Settings - Internal  
Hexagon Headed Capscrews (Zinc)**

<b>Bolt Size</b>	
<b>mm</b>	<b>N·m</b>
3	2
4	6
5	11
6	19
8	46
10	91
12	159
16	395
18	550
20	770
24	1,332

## 06 - Bolts

### 00 - General

Introduction ..... 72-6  
 Technical Data ..... 72-7

### Introduction

Use the torque setting tables (Technical Data) only where no torque setting is specified in the text. Note: Dacromet fasteners are lubricated as part of the plating process, do not lubricate. Torque settings are given for the following conditions:

**Table 103. Up to September 2017**

Type	Condition 1	Condition 2
no coating	Unlubricated fasteners	Zinc flake silver (Dacromet) fasteners.
2 (obsolete from September 2017).	Zinc fasteners	Lubricated zinc and yellow plated fasteners.
3, 4 (obsolete from September 2017).	Yellow plated fasteners	Where there is a natural lubrication. For example, cast iron components.

**Table 104. From September 2017**

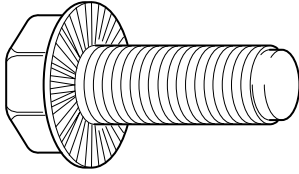
Type (suffix)	Condition 1	Condition 2
no coating	Unlubricated fasteners	Where there is a natural lubrication. For example, cast iron components
1 (D)		Zinc flake silver (Dacromet, Geomet) fasteners.
5 (V or Z)		Zinc and heavy trivalent with seal
7 (G) <sup>(1)</sup>		Zinc nickel - silver
8 (N) <sup>(1)</sup>		Zinc nickel - black
9 (B) <sup>(1)</sup>		Zinc flake - black

*(1) With integrated torque control lubricant.*

### Verbus-Ripp Bolts

Torque settings for these bolts are determined by the application. Refer to the relevant procedure for the required settings.

Figure 300.



**Technical Data**

From JCB standard STD00019 issue 07.

1. This information does not apply to:-
  - 1.1. Hydraulic fittings (i.e. BSP, SAE O-ring boss, UNF, four bolt split flange and JIC).
  - 1.2. Locking type fasteners (those with a nylon insert, or with distorted thread nuts such as Cleveloc).
2. For information on fastener conditions, refer to fasteners and fixings, bolts, general, introduction.

**Table 105. Torque Settings - UNF S Fasteners**

Bolt Size	Treads per Inch	Hexa-gon (A/F)	Condi-tion 1	Condi-tion 2
in	in	in	N·m	N·m
(1/4 in)	28	7/16	11.2	10
(5/16 in)	24	1/2	22.3	20
(3/8 in)	24	9/16	40	36
(7/16 in)	20	5/8	64	57
(1/2 in)	20	3/4	98	88
(9/16 in)	18	13/16	140	126
(5/8 in)	18	15/16	196	177
(3/4 in)	16	1 1/8	343	309
(7/8 in)	14	1 15/16	547	492
(1 in)	12	1 1/2	814	732
(1 1/8 in)	12	1 7/8	1,181	1,063
(1 1/4 in)	12	2 1/4	1,646	1,481

**Table 106. Torque Settings - UNF X Fasteners**

Bolt Size	Treads per Inch	Hexa-gon (A/F)	Condi-tion 1	Condi-tion 2
in	in	in	N·m	N·m
(1/4 in)	28	7/16	17.6	15.9
(5/16 in)	24	1/2	35.2	31.6
(3/8 in)	24	9/16	64	57
(7/16 in)	20	5/8	101	91
(1/2 in)	20	3/4	155	139
(9/16 in)	18	13/16	221	199
(5/8 in)	18	15/16	310	279
(3/4 in)	16	1 1/8	542	488
(7/8 in)	14	1 15/16	864	777
(1 in)	12	1 1/2	1,285	1,156
(1 1/8 in)	12	1 7/8	1,865	1,679
(1 1/4 in)	12	2 1/4	2,598	2,339

**Table 107. Torque Settings - Coarse Metric Grade 8.8 Fasteners**

Bolt Size	Tread Pitch	Hexa-gon (A/F)	Condition 1	Condition 2
mm	mm	mm	N·m	N·m
4	0.7	7	2.9	2.6
5	0.8	8	5.8	5.2
6	1	10	9.9	9
8	1.25	13	24	22
10	1.5	17	47	43
12	1.75	19	83	74
14	2	22	132	119
16	2	24	205	184
20	2.5	30	400	360
24	3	36	690	621
30	3.5	46	1,372	1,235
36	4	55	2,399	2,159

**Table 108. Torque Settings - Coarse Metric Grade 10.9 Fasteners**

Bolt Size	Thread Pitch	Hexa-gon (A/F)	Condition 1	Condition 2
mm	mm	mm	N·m	N·m
4	0.7	7	4	3.6
5	0.8	8	8.1	7.3
6	1	10	13.9	12.5
8	1.25	13	34	30
10	1.5	17	67	60
12	1.75	19	116	104
14	2	22	185	167
16	2	24	288	259
20	2.5	30	562	506
24	3	36	971	874
30	3.5	46	1,930	1,737
36	4	55	3,374	3,036

**Table 109. Torque Settings - Coarse Metric Grade 12.9 Fasteners**

Bolt Size	Thread Pitch	Hexa-gon (A/F)	Condition 1	Condition 2
mm	mm	mm	N·m	N·m
4	0.7	7	4.8	4.4
5	0.8	8	9.8	8.8
6	1	10	16.6	15
8	1.25	13	40	36
10	1.5	17	80	72
12	1.75	19	139	125
14	2	22	223	200
16	2	24	345	311

Bolt Size	Thread Pitch	Hexa-gon (A/F)	Condition 1	Condition 2
mm	mm	mm	N·m	N·m
20	2.5	30	674	607
24	3	36	1,165	1,048
30	3.5	46	2,316	2,084
36	4	55	4,049	3,644

**Table 110. Torque Settings - Fine Metric Grade 8.8 Fasteners**

Bolt Size	Tread Pitch	Nom-inal Stress Area	Proof Load	Pre-load (75% Proof Load)	Torque
mm	mm	mm <sup>2</sup>	kN	kN	N·m
8	1	39.2	22.7	17.025	21
10	1.25	61.2	33.5	25.125	38
12	1.25	92.1	53.5	40.125	74
14	1.5	125	72.5	54.375	116
16	1.5	167	96.9	72.675	178
18	1.5	216	130	97.5	268
20	1.5	272	163	122.25	374
22	1.5	333	200	150	505
24	2	384	230	172.5	633

**Table 111. Torque Settings - Fine Metric Grade 10.9 Fasteners**

Bolt Size	Tread Pitch	Nom-inal Stress Area	Proof Load	Pre-load (75% Proof Load)	Torque
mm	mm	mm <sup>2</sup>	kN	kN	N·m
8	1	39.2	32.5	24.4	30
10	1.25	61.2	50.8	38.1	58
12	1.25	92.1	76.3	57.2	105
14	1.5	125	104	93.8	201
16	1.5	167	139	104.3	255
18	1.5	216	179	134	370
20	1.5	272	226	169.5	519
22	1.5	333	276	207	698
24	2	384	319	239.3	879

**Table 112. Torque Settings - Fine Metric Grade 12.9 Fasteners**

Bolt Size	Tread Pitch	Nom-inal Stress Area	Proof Load	Pre-load (75% Proof Load)	Torque
mm	mm	mm <sup>2</sup>	kN	kN	N·m
8	1	39.2	38	28.5	35
10	1.25	61.2	59.4	44.5	68

Bolt Size	Tread Pitch	Nom-inal Stress Area	Proof Load	Pre-load (75% Proof Load)	Torque
mm	mm	mm <sup>2</sup>	kN	kN	N·m
12	1.25	92.1	89.3	67	123
14	1.5	125	121	90.75	195
16	1.5	167	162	121.5	297
18	1.5	216	210	157.5	434
20	1.5	272	264	198	606
22	1.5	333	323	242	733
24	2	384	372	279	1,025

**Table 113. Torque Settings - Rivet Nuts / Bolts**

Bolt Size	
mm	N·m
3	1.2
4	3
5	6
6	10
8	24
10	48
12	82

JCB © CONNOR STANMORE - 13/03/2026 07:57.





---

## 75 - Consumable Products

Contents	Page No.
<a href="#">Acronyms Glossary</a> .....	75-2
75-00 Consumable Products	
<a href="#">75-00-00 General</a> .....	75-3
<a href="#">75-00-03 Parts List</a> .....	75-6
75-09 Fluids	
<a href="#">75-09-00 General</a> .....	75-7
75-10 Locking Fluids	
<a href="#">75-10-00 General</a> .....	75-8
75-14 Solvents and Primers	
<a href="#">75-14-00 General</a> .....	75-11
75-15 Adhesive	
<a href="#">75-15-00 General</a> .....	75-14
75-16 Sealant	
<a href="#">75-16-00 General</a> .....	75-19



---

## Acronyms Glossary

PTFE      Polytetrafluoroethylene



## 00 - Consumable Products

### 00 - General

Introduction .....	75-3
Health and Safety .....	75-4
Technical Data .....	75-5

### Introduction

JCB recommend that you use the JCB lubricants shown as they have been verified by JCB for use on JCB machines. However, you could use other lubricants that are equivalent to the JCB standards and quality or offer the same machine component protection.

Before you start work, make sure that:

- All safety precautions are observed in accordance with the information contained within the relevant support documentation.
- The consumables are used in accordance with the manufacturer's recommendations.
- The consumables shown are available in the correct quantity.

Consumables other than those listed may be required. It is expected that general consumables will be available in any well equipped workshop or be available locally.

JCB © CONNOR STANMORE - 13/03/2026 07:57.

## Health and Safety

### Fluid Under Pressure

Fine jets of fluid at high pressure can penetrate the skin. Keep face and hands well clear of fluid under pressure and wear personal protective equipment. Hold a piece of cardboard close to suspected leaks and then examine the cardboard for signs of fluid. If fluid penetrates your skin, get medical help immediately.

### Hygiene

JCB lubricants are not a health risk when used correctly for their intended purposes.

However, excessive or prolonged skin contact can remove the natural fats from your skin, causing dryness and irritation.

Low viscosity oils are more likely to do this, so take special care when handling used oils, which might be diluted with fuel contamination.

Whenever you are handling oil products you must maintain good standards of care and personal and plant hygiene. For details of these precautions we advise you to read the relevant publications issued by your local health authority, plus the following.

### Storage

Always keep lubricants out of the reach of children.

Never store lubricants in open or unlabelled containers.

### Waste Disposal

**▲ CAUTION** It is illegal to pollute drains, sewers or the ground. Clean up all spilt fluids and/or lubricants.

Used fluids and/or lubricants, filters and contaminated materials must be disposed of in accordance with local regulations. Use authorised waste disposal sites.

**CAUTION** Damaged or spent batteries and any residue from fires or spillage must be put in a suitable closed receptacle and must be disposed of in accordance with local environmental waste regulations.

All waste products must be disposed of in accordance with all the relevant regulations.

The collection and disposal of used hydraulic oil must be in accordance with any local regulations. Never pour used hydraulic oil into sewers, drains or on the ground.

## Handling

### New Oil

There are no special precautions needed for the handling or use of new oil, beside the normal care and hygiene practices.

### Used Oil

Here are precautions to protect your health when handling used hydraulic oil:

- Avoid prolonged, excessive or repeated skin contact with used oil
- Apply a barrier cream to the skin before handling used oil. Note the following when removing hydraulic oil from skin:
  - Wash your skin thoroughly with soap and water
  - Using a nail brush will help
  - Use special hand cleansers to help clean dirty hands
  - Never use petrol, diesel fuel, or paraffin for washing
- Avoid skin contact with oil soaked clothing
- Don't keep oily rags in pockets
- Wash dirty clothing before re-use
- Throw away oil-soaked shoes

### First Aid - Oil

#### Eyes

In the case of eye contact, flush with water for 15min. If irritation persists, get medical attention.

#### Swallowing

If oil is swallowed do not induce vomiting. Get medical advice.

#### Skin

In the case of excessive skin contact, wash with soap and water.

#### Spillage

Absorb with sand or a locally approved brand of absorbent granules. Scrape up and remove to a chemical disposal area.

#### Fires

**▲ WARNING** Do not use water to put out an oil fire. This will only spread it because oil floats on water.

Extinguish oil and lubricant fires with carbon dioxide, dry chemical or foam.



## Technical Data

JCB recommend that you use the JCB fluids and lubricants shown as they have been verified by JCB for use on JCB machines. However, you could

use other lubricants that are equivalent to the JCB standards and quality or offer the same machine component protection.

**Table 114.**

Item	Capacity	Fluid/Lubricant	JCB Part Number	Container Size <sup>(1)</sup>	Specification
Hydraulic system	14–22L	JCB HVI Hydraulic Oil 32 <sup>(3, 4)</sup>	4002/3520	20L	Viscosity index - 299 ISO grade - 32 Flash point of oil - 186°C (366.5°F)
		JCB Arctic Hydraulic Fluid 32 <sup>(3, 4)</sup>	4002/2805	20L	Viscosity index - 353 ISO grade - 32 Flash point of oil - 100°C (211.9°F)
Grease points	-	JCB Special HP Grease	4003/2000	0.4kg	
Electrical connections	-	As a corrosion and moisture inhibitor all exposed connections should be coated liberally with petroleum jelly	-	-	
Wheel motor	0.15–0.3L	JCB Advanced Gear Oil 68 <sup>(2)</sup>	4000/0404	1L	<ul style="list-style-type: none"> <li>High industrial performance.</li> <li>Long service life of lubricant.</li> <li>Optimum wear and corrosion protection.</li> </ul>
			4000/0401	5L	

(1) For information about the different container sizes that are available (and their part numbers), contact your JCB dealer.

(2) For Dana gearboxes only.

(3) Suitable for stable performance across wide temperature range. JCB recommends to use hydraulic oil of viscosity index  $\geq 200$ .

(4) Zinc free. Do not mix with conventional fluids. Completely flush the system for any changeover from conventional oil.



03 - Parts List

Introduction

Consumables

Description	Part No.	Size
Special HP Grease	4003/2020	0.5kg
	4003/2017	0.4kg
	4003/2006	12.5kg
	4003/2005	50kg
Surface Cleaning Fluid	4103/1204	1L
Wiring Splice (0.5-1.5mm Red, contains 50 off)	892/00351	-
Wiring Splice (1.5-2.5mm Blue, contains 50 off)	892/00352	-
Wiring Splice (3-6mm Yellow, contains 50 off)	892/00353	-
Wiring Splice-Bootlace (1mm Red)	7205/0100	-
Wiring Splice-Bootlace (2.5mm Grey)	7205/0250	-

JCB © CONNOR STANMORE - 13/03/2026 07:57.

## 09 - Fluids

### 00 - General

#### Introduction

It is most important that you read and understand this information and the publications referred to. Make sure all your colleagues who are concerned with lubricants read it too.

#### Hygiene

JCB lubricants are not a health risk when used properly for their intended purposes.

However, excessive or prolonged skin contact can remove the natural fats from your skin, causing dryness and irritation.

Low viscosity oils are more likely to do this, so take special care when handling used oils, which might be diluted with fuel contamination.

Whenever you are handling oil products you should maintain good standards of care and personal and plant hygiene. For details of these precautions we advise you to read the relevant publications issued by your local health authority, plus the following.

#### Storage

Always keep lubricants out of the reach of children. Never store lubricants in open or unlabelled containers.

#### Waste Disposal

All waste products should be disposed of in accordance with all the relevant regulations.

The collection and disposal of used oil should be in accordance with any local regulations.



## 10 - Locking Fluids

### 00 - General

Introduction ..... 75-8  
 Technical Data ..... 75-9

### Introduction

All locking fluids should be used at all times in line with the manufacturer’s recommendations.

Locking fluids are used for the locking of threaded fasteners and for the retention of ball & roller bearings and similar cylindrical items on to shafts and into housings. These fluids consist of an anaerobic resin in a liquid form which hardens when confined between closely fitting metal to metal and many metal to non-metal surfaces.

The fluids available possess a wide span of break-loose strengths, viscosities and gap filling properties and are marketed for a variety of locking and retaining purposes requiring different strength grades. Some of the sealants in use in JCB are also of anaerobic resin type and only differ from the locking fluids in respect of viscosity and other technical details.

### Strength grades

Various strength grades of fluid are available, the highest strength type for permanent locking where disassembly is unlikely, medium strength for permanent locking but allowing disassembly with ordinary tools and low strength for locking of components where frequent adjustment or easy dismantling is required.

It is recommended that trials be carried out before scheduling locking fluids for any new type of application that has not been already proved as satisfactory in production or when use at elevated temperatures is intended.

Additional technical information is normally available from the product manufacturers.

### Approved locking fluids

The table shown in Technical Data shows the approved locking fluids available to use on JCB machines. The table also provides basic details to help with selection of locking fluids. More up to date information can be found on the manufacturer’s website.

**Technical Data**
**Table 115. Locking Fluids Approved Product Information**

Subsec-tion	Commer-cial name	Product Number	Colour	Shelf life	Strength	Comments
High strength	Loctite 270 <sup>(1)</sup>	4101/0100	Green fluorescent	365d	80–120bar (1,160.3–1,740.5psi) breakaway strength	For the retention of threads up to M20 diameter where disassembly is unlikely and for locking bearings etc. onto shafts and into housing. Has a maximum gap fill of 0.05mm.
	R.A.S. threadlock for studs <sup>(1)</sup>		Red			
High strength	Loctite 638	4101/1400	Green, UV fluorescent	365d	More than 250bar (3,625.9psi) compressive shear strength	Maximum gap fill of 0.25mm. Maximum strength at room temperature.
High strength	Per-mabond A115 <sup>(1)</sup>	4101/0500	Red, fluorescent	365d	100–150bar (1,450.4–2,175.6psi) prevailing strength	Fast curing (10–15min) thread locking up to M20, especially for use on oily surfaces, plated and clean parts.
	Loctite 262					
High strength	Loctite 648 <sup>(1)</sup>	4101/0600	Green, fluorescent	365d	More than 250bar (3,625.9psi) compressive shear strength	Designed for holding gears and sprockets onto gearbox shafts and rotors on electric motor shafts.
	Per-mabond A118					
High strength	Loctite 2701	4101/1700	Green	365d	260–500bar (3,771.0–7,251.9psi) breakaway torque	Designed for permanent locking and sealing of threaded fasteners. Particularly suited for use on inactive substrates and/or where maximum resistance to hot oil is required.
Medium to high	Loctite 243	4101/1100	Blue	365d	140–340bar (2,030.5–4,931.3psi) breakaway torque	Suitable for all nuts, bolts, screws up to M36.
Medium strength	Per-mabond A119 <sup>(1)</sup>	4101/0900	Blue	365d	80–120bar (1,160.3–1,740.5psi) static shear strength	Maximum gap fill of 0.25mm. Handling strength in 10–15min.
Medium strength	Loctite 640	4101/1200	Green, fluorescent	365d	150–330bar (2,175.6–4,786.2psi) static shear strength	Product has a slow cure rate, used on parts unlikely to be disassembled.
Medium strength	Loctite 242 <sup>(1)</sup>	4101/0200	Blue, fluorescent	365d	80–120bar (1,160.3–1,740.5psi) static shear strength	Suitable for all nuts, bolts and screws up to M36 and hydraulic fittings up to 25mm in diameter. Per-mabond A113 and A1042 are the preferred choices. The difference between A113 and A1042 is timing for handling and working strength. A113 handling time 10–25min, working strength 1h. A1042 handling time 5–10min, working strength 30min.
	Per-mabond A1042					
	Per-mabond A113					



## 75 - Consumable Products

10 - Locking Fluids

00 - General

Subsection	Commercial name	Product Number	Colour	Shelf life	Strength	Comments
Low strength	Loctite 222	4101/0300	Purple, fluorescent	365d	15–40bar (217.6–580.2psi)	For screwed fasteners up to M20 that require easy disassembly or frequent adjustment. Maximum gap fill of 0.05mm. Achieves handling strength in 10–30min.
Low strength	Per-mabond A1098	4101/1500	Blue	365d	120bar (1,740.5psi) shear strength	Allows dismantling of parts for maintenance. Suitable for sealing small hydraulic and pneumatic fittings. Handling strength in 5–10min.
Low strength	Loctite 567	4101/1600	Off-white	365d	17bar (246.6psi) breakaway torque	For the locking and sealing of metal tapered threads and fittings. High lubricating properties prevent galling on stainless steel, aluminium and all other metal pipe threads and fittings.
Very low strength	Loctite 932 <sup>(1)</sup> Per-mabond A011	4101/0400	Brown/red	365d	7–18bar (101.5–261.1psi) average shear strength	Can be disassembled with hand tools. 10–30min cure time for handling strength. Used on large diameter screw threads bigger than 50mm.

(1) This is a non preferred product.



## 14 - Solvents and Primers

### 00 - General

Introduction ..... 75-11  
Technical Data ..... 75-12

### Introduction

This section contains information on primers, solvents, cleaning solutions etc. that are in use at JCB.

All primers and solvents should be used at all times in line with the manufacturer's recommendations.

### Approved primers and solvents

The table shown in Technical Data shows the approved primers and solvents available to use on JCB machines. The table also provides basic details to help with the selection of primers and solvents. More up to date information can be found on the manufacturer's website.

JCB © CONNOR STANMORE - 13/03/2026 07:57.

**Technical Data**
**Table 116. Primers and Solvents Approved Product Information**

Subsec-tion	Commer-cial name	Product Number	Colour	Shelf life	Drying Time	Comments
Activa-tor/Primer	Loctite 770	332/U7901	Colour-less	365d	Less than 5s	Used to make low energy surfaces suitable for bonding with cyanocrylate adhesives. It is recommended for polyethylene, polypropylene, PTFE and thermoplastic rubber materials. Can be used with Loctite 406 (332/U7899).
Activator	Loctite 7455	4104/1700	Clear amber	730d	Apply and leave to dry for 30s before applying adhesive	HIGHLY FLAMMABLE. Organic accelerator, non CFC solvent based surface activator. Designed to promote the speed of cure of cyanoacrylic adhesives.
Activator	Loctite 7471 <sup>(*)</sup> Per-mabond A905	4104/0200	Colour-less	365d	1–3min	Used with anaerobic products it increases cure speed. Recommended for inert surfaces and large bond gaps.
Water proofing	Loctite water proofing	4104/0500	-	-	-	A water proofing solution for protecting joints made using cyanoacrylate adhesive. Apply to Loctite 495 (4103/0900).
Solvent	Loctite 7063 <sup>(*)</sup>	4104/1500	Colour-less	365d	1min at 20°C (68.0°F)	HIGHLY FLAMMABLE, cleaner and degreaser. Removes grease, oil and dirt from electrical parts, tools and precision equipment.
Cleaning fluid	Loctite 7070	4101/2200	Colour-less	365d	No wipe 5–10min, post wipe 1–2min	Cleaning treatment to remove most greases, oils, lubrication fluids and metal cuttings
Cleaning fluid	Simple green extreme	332/E9240	Colour-less	365d	-	An all purpose cleaner and degreaser used diluted in water for direct, spray and dip tank procedures.
Applica-tion fluid	A4G-BCJCB	4104/3300	Blue	730d	-	Vinyl labels application fluid for use with the insignia/livery labels.
Gasket cleaner	Loctite 7200	4104/3200	Colour-less	730d	Allow 10–15min for gasket, 30min for silicone gasket.	This is a product to aid the removal of cured chemical gaskets. Apply for time specified and remove gasket with soft scraper.
Hand cleaner	Loctite 7855	4104/3100	Light grey	540d	-	Is a heavy duty hand cleaner, specially formulated for the most difficult to remove soils like polyurethane, paints, primers, adhesives etc. The product is free from silicone and harsh solvents. Can be used without water.
Hand cleaner	Sika hand cleaner	4104/1300	Off white	-	-	A non-abrasive hand cleaner for use when using direct glazing materials.



Subsec- tion	Commer- cial name	Product Number	Colour	Shelf life	Drying Time	Comments
Direct glazing	Sika acti- vator	4104/2100	Clear	365d	10min mini- mum drying time	HIGHLY FLAMMABLE. A cleaning and acti- vating agent specifically formulated for the treatment of bonded faces in direct glaz- ing applications prior to applying the direct glazing adhesive.
Direct glazing	Sika re- mover 208 (use 4104/3600) <sup>(1)</sup>	4104/1900	Trans- parent	-	-	A cleaning agent for removing contami- nates on painted surfaces and glass.
Direct glazing	Sika cleaner 205 (use 4104/3600) <sup>(1)</sup>	4104/1200	Clear	-	-	A cleaning agent for removing contami- nates on painted surfaces and glass.
Direct glazing	Sika primer 209 (use 4104/3500) <sup>(1)</sup>	4104/2300	Black	270d	-	Used to prepare painted surfaces and plas- tic substrates prior to bonding with Sikaflex products.
Direct glazing	Sika akti- vator	4104/2400	Clear	365d	10min at more than 15°C (59.0°F) or 30min at less than 15°C (59.0°F)	Used to clean and give improved adhe- sion on glass, ceramic-coated glass, the cut face of old polyurethane adhesive beads, polyurethane coated windows glass and paints.
Active wipe for surface	Tero- stat 8560 AC-25	4104/3400	Colour- less	270d	Minimum 30s and maximum 1h	Applied with a clean cloth to the surface, the adhesive may then be applied after the drying time. Applied to glass or ceramic coating but only in the bonding area.
Direct glazing	Terostat 8519 P	4102/3500	Black	365- 540d	Approx. 2min	Used to promote adhesion in direct glazing to glass and glass ceramics.
Cleaner	Teroson FL clean- er	4104/3600	Clear	730d	Depend- ing on con- ditions be- tween 2- 10min.	Used for degreasing and cleaning of sub- strates prior to application of adhesives and sealants.
Adhe- sion pro- moter	3M AP III	4104/3700	-	-	-	Used to prepare a painted surface before adhering (LDL) door seals (to increase ad- hesion of 3M 5337A) before installation of the cab.

(1) This is a non preferred product.



## 15 - Adhesive

### 00 - General

Introduction ..... 75-14  
Technical Data ..... 75-15

### Introduction

All adhesives should be used at all times in line with the manufacturer's recommendations.

Adhesives are used for the bonding of a number of engineering materials used in production at JCB. Many types are available on the market but in the interests of variety reduction and economy only a limited selection is purchased for regular use.

### Types of adhesive

Various types of adhesive are covered by JCB Standards:

1. General purpose adhesives for bonding laminated plastics, wood, rubber etc. to themselves and to each other.
2. The more expensive cyanoacrylate adhesives for use where high strength, resistance to many chemicals and fast cure times are required.
3. Adhesives specially developed for bonding of foam rubber to painted metal surfaces.

### Additional health and safety for cyanoacrylates

These adhesives require very careful handling on account of their exceptional properties. They bond together strongly and rapidly to most surfaces including body tissue, the curing process being initiated by surface moisture. For further information on cyanoacrylates refer to the Manufacturer's recommendations.

### Approved adhesives

The tables shown in Technical Data are the approved adhesives available to use on JCB machines. The tables also provide basic details to help with the selection of adhesives. More up to date information can be found on the manufacturer's website.

## Technical Data

**Table 117. Adhesives Approved Product Information**

Subsec-tion	Commer-cial name	Product Number	Colour	Shelf life	Technical data	Comments
High strength	Per-mabond 5002	4103/3100	Mixed grey	730d	3–5min for handling strength	Two part adhesive mixed in equal parts. A toughened adhesive system which bonds metals, plastics, wood, glass, ceramics and composites; even plated or coated surfaces can be securely fastened.
High strength	Loctite 601	4103/1000	Green fluorescent	365d	160–300bar (2,320.6–4,351.1psi) static shear strength	This product is a single component anaerobic adhesive. Used to bond cylindrical fitting parts, particularly where low viscosity is required. Maximum gap fill is 0.15mm.
Cyano-acrylate	Loctite 424	4103/3500	Colourless to straw	-	180–260bar (2,610.7–3,771.0psi) shear strength	Suitable for most materials including plastic and rubber. Takes 30s to cure to working strength.
Cyano-acrylate	Loctite 401	4103/2300	Colourless	180d	180–260bar (2,610.7–3,771.0psi) tensile strength	Designed for general purpose use. For use on acidic and porous surfaces, reaching handling strength in seconds. Materials include plated metals, composite materials, wood, cork, foam, leather and paper.
Cyano-acrylate	Loctite 406	332/U7899	Colourless	180d	180–260bar (2,610.7–3,771.0psi) lap shear strength	Designed for bonding of plastics and elastomeric materials where very fast fixturing is required. Can be used with Loctite 770 as a primer (332/U7901)
Cyano-acrylate	Loctite 410	4103/2400	Black	120d	220bar (3,190.8psi) lap shear strength	0.2mm, gap fill. A rubber toughened ethyl cyanoacrylate adhesive with enhanced resistance to peel and shock. Bonds rubber, metals and plastics for use in difficult conditions.
Cyano-acrylate	Loctite 480	4103/3800	Black	-	220–300bar (3,190.8–4,351.1psi) lap shear strength	A rubber toughened adhesive with increased flexibility and peel strength along with enhanced resistance to shock.
Cyano-acrylate	Loctite 495 <sup>(1)</sup>	4103/0900	Colourless	270d	12h maximum cure time	High speed bonding, suitable for rubber to itself and other materials reaching handling strength in a matter of seconds. Joint must be waterproofed with Loctite water proofing (4104/0500).
	Per-mabond C2					
Low strength	Dunlop 1727	4103/1100	Clear to light straw	90d	-	Sprayable adhesive, non-structural applications. For the bonding of flexible foam to themselves, wood, painted metal, chip-board, fibreglass, hessian, felt etc.
	British vita company VB 165					



Subsec-tion	Commer-cial name	Product Number	Colour	Shelf life	Technical data	Comments
Acrylic foam strip ad-hesive	3M 4941P	4103/3900	Dark grey	730d	Peel ad-hesion 350N/100mm	High bond acrylic double sided foam tape. Its allows more complete bond contact area when bonding rigid or irregular materials due to its conformability. Its core adhesive composition makes the product well suited to many paints and primers.
General purpose gap fill-ing ma-terial	Araldite XD 580	4103/1400	Clear / cream	730d	560bar (8,122.1psi) flexural strength	Two part, equal parts by weight. Wear pad fixing to castings and telescopic compo-nents, alignments of fixings pads without expensive machining. This product is a general purpose gap-filling material. Cure time 2h at 25°C (77.0°F).
Methacry-late	Loctite Speed-bonder H3151	4103/3600	Cream to light yellow	-	-	This is a sag resistant, two component, equal parts, methacrylate adhesive system formulated to bond automotive grade cold rolled steel without the use of an external primer. Suitable for bonding a wide variety of plastic and metal substrates. Provides a long open time (40–60min) for correct align-ing of parts.
Methacry-late	Plexus MA420	4103/3700	Off-white or blue	365d	-	Two part methacrylate adhesive for struc-tural bonding of thermoplastic, metal and composite assemblies. Combined at 10:1 ratio. It has a working time of 4–6min.
Structur-al plastic	Scotch-weld DP-8005	332/S7420	Black	180d	-	Two part acrylic based adhesive (10:1 ra-tio by vol.) that can bond many low surface energy plastics, including many grades of polypropylene, polyethylene and TPO's without special surface preparation.
General purpose adhesive	Evo-Stick 528 <sup>(1)</sup>	4103/0800	-	365d	HIGHLY FLAMMA-BLE	A thin even film of adhesive should be ap-plied to both surfaces being bonded and al-lowed to become touch dry. This is a con-tact adhesive and coated surfaces can-not therefore be slid into position since the bond forms on contact. It is often conve-nient to align the parts along an edge and then bring the two areas into contact.
Direct glazing	Sika 250PC Sikat-ack Ultra-fast (use 4103/4000 or 4102/4900) <sup>(1)</sup>	4103/2100	Black	-	-	A one component polyurethane pre-poly-mer based adhesive. A mastic adhesive which reacts with atmospheric moisture to form a rubber like solid.
Direct glazing	Sika 255FC (use 4102/5000) <sup>(1)</sup>	4103/2200	Black	-	-	For bonding glass to cab frames. A mas-tic adhesive which reacts with atmospheric moisture to form a rubber like solid. When using this product ensure both surfaces are clean and dry. Use Sika cleaner 205 (4104/1200).
Direct glazing	Sikaflex 552 (use 4102/5000) <sup>(1)</sup>	4103/3200	Black	-	-	A high performance, elastic, gap, filling one part structural adhesive cures on exposure to atmospheric moisture to form a durable elastomer. Contains no isocyanate.

JCB © CONNOR STANMORE - 13/03/2026 07:57.

**75 - Consumable Products**15 - Adhesive  
00 - General

Subsection	Commercial name	Product Number	Colour	Shelf life	Technical data	Comments
Industrial grade epoxy adhesive	Loctite Hysol E-214 HP	333/Y7062	Light Grey Paste	-	307bar (4,452.7psi) tensile strength	Single component, heat activated formulation develops tough, strong, structural bonds which provide excellent peel resistance and impact strength. When fully cured, the product offers superior thermal shock resistance, excellent mechanical and electrical resistance properties and withstands exposure to a wide variety of solvents and chemicals. Bonds to a wide variety of materials, including metals, glass, ceramics and plastics. Cure at 120°C (247.8°F) or above until completely firm. Heat up to 150°C (301.8°F) for 2h, to maximize properties.
Anaerobic adhesive (Dimethacrylate)	Scotch-weld RT-20	333/L9575	Green	365d	-	Single component anaerobic adhesives designed to secure cylindrical metal assemblies such as bearings on shafts, bushings, sleeves, housings, and keyways. Help prevent loosening, corrosion and leakage caused by shock and vibration. Full cure time 24h. Temperature range = -54°C (129.1°F) to 450°C (841.4°F). Not recommended for use on most plastics due to potential cracking of plastic parts.
Direct glazing	Teroson 939CT / Terostat MS939	4102/5000	Black	365d in original packaging	-	Skin formation time: approx. 10min. Cure rate: approx. 3mm/24h.
Direct glazing	Terostat 8900 HV	4103/4000	Black	180d	80bar (1,160.3psi) tensile strength	One component, pumpable adhesive/sealant based on polyurethane, which cures by reaction with moisture to an elastic rubber. The skin formation and curing time are dependent on humidity, temperature and depth of joint. High temperature and high moisture reduces curing time. Sag resistant, temperature range of -40°C (103.9°F) to 90°C (193.9°F).
Direct glazing	Terostat 8594 HMLC	4103/4100	Black	270d	85bar (1,232.8psi) tensile strength	Single component, moisture curing, adhesive/sealant for repair. Product with high shear modulus and low conductivity. Suitable for all applications that require very high electrical insulation of the adhesive used for the bonding of windows. Sag resistant.

JCB © CONNOR STANMORE - 13/03/2026 07:57.



## 75 - Consumable Products

15 - Adhesive  
00 - General

Subsection	Commercial name	Product Number	Colour	Shelf life	Technical data	Comments
Direct glazing	Terostat 8900 LV	4103/4200	Black	365d in cartridges 180d in sausage pack. 180d in hobbocks and drums	80bar (1,160.3psi) tensile strength	One component, pumpable adhesive/sealant based on polyurethane, which cures by reaction with moisture to an elastic rubber. The skin formation and curing time are dependent on humidity, temperature and depth of joint. High temperature and high moisture reduces curing time. Sag resistant, temperature range of -40°C (103.9°F) to 90°C (193.9°F) short exposure (up to 1h) of 130°C (265.8°F).
Direct glazing	Sikaflex 295 UV	4103/4300	Black, white	365d	-	Direct glazing adhesive for plastic glazing panels. One component polyurethane adhesive of paste like consistency. 60min tack free time, 1d cure time (4mm at 23°C (73.4°F)). Good UV, fresh water and seawater resistance. Do not apply below temperatures of 10°C (50.0°F) or above 35°C (95.0°F).
High strength retainer	Loctite 603	4103/2500	-	-	-	Used for bearings.
Direct glazing	Teroson MS 660	4103/5000	Clear	365d	-	Area must be clean, dry, oil and grease free and not be in permanent contact with water. Provides a long open time approximately 15min for correct aligning of parts.
Medium strength thread-locker	Loctite 2400	4103/5100	Blue	-	-	Can be used in place of Loctite 243.
Direct glazing	Terostat 8910 (also known as Teroson PU 8910)	4103/5200	Black	-	Cure rate 3.5mm/24h	component with high viscosity, pumpable adhesive / sealant cures by reaction with moisture, humidity and temperature. Provides a long open time approximately 10min for correct aligning of parts.
Flange adhesive	Teroson RB 5100	320/B4113	Greyish black	90d	-	Thermosetting component, solvent free, reactive rubber based flange adhesive
Structural adhesive	AK 348	4103/5300	-	-	-	Used as structural adhesive.
Structural adhesive	Loctite V1315	4103/5400	Cream, Off white	365d	-	Used for bonding powder coated glazing strips onto the powder coated cab welded assemblies.

(1) This is a non preferred product.



## 16 - Sealant

### 00 - General

Introduction ..... 75-19  
Technical Data ..... 75-20

### Introduction

All sealants should be used at all times in line with the manufacturer’s recommendations. Sealants are used mainly for the sealing of screwed joints, sealing flanges and flat surfaces and where gap filling properties are required.

### Types of Sealant

Various types of sealant are specified in JCB Standards:

1. Those for the sealing of screwed joints.
2. Sealants for joining flanges and flat surfaces. (Flange size and likelihood of dismantling require consideration when selecting this type of sealant).
3. Sealants for use where gap filling properties are required. (The gap dimensions, joint movement if any, type of materials being joined and aesthetic appearance require consideration when selecting this type of sealant).

### Approved Sealants

The table shown in Technical Data are the approved sealants available to use on JCB machines. The table also provides basic details to help with selection of sealants. More up to date information can be found on the manufacturer’s website.

JCB © CONNOR STANMORE - 13/03/2026 07:57.

## Technical Data

**Table 118. Sealants Approved Product Information**

Subsec-tion	Com-mercial name	Product Number	Colour	Shelf life	Technical data	Comments
High strength	Loctite 275 <sup>(1)</sup>	4102/0500	Green	730d	250bar (3,625.9psi) torque strength (on M8)	Non drip formulation, used on larger fittings, coarse threads.
	Per-mabond A140					
High strength	Forge-way 240FC <sup>(1)</sup>	4102/3100	Yellow	270d	25bar (362.6psi) breaking strength	Can be painted over with some 2 pack paint. Maximum width of joint =35mm, minimum width =2mm, minimum depth =2mm. Recommended depth of joint = width of joint.
Medium to high strength	Loctite 620	4102/3500	Green	-	More than 241bar (3,495.4psi) shear strength	Used for locating pins in radiator assemblies, sleeves into pump housings and bearings in auto transmissions. Not suitable for plastics. Diametrical clearance: up to 0.2mm
Medium strength	Loctite 518 Gasket Eliminator	4102/2000	Red, fluorescent	365d	90bar (1,305.3psi) tensile strength	Typically used as form-in-place gasket on rigid flanged connections.
Medium strength	Loctite 5182	4102/4100	Red gel, fluorescent	-	80bar (1,160.3psi) shear strength	It is manufactured to minimise air bubbles in the package. Used to seal gaskets, housings, cases and covers. It can also be used to repair and replace cut gaskets (up to 0.08mm in thickness).
Medium strength	Loctite 595	4102/2500	Clear	365d	6mm gap filling	Formulated to withstand weathering and extreme temperature cycling. Used for potting, coating and sealing. Can be applied horizontal, vertical and overhead.
Medium strength	Loctite 577 <sup>(1)</sup>	4102/1900	Yellow	365d	170bar (2,465.6psi) breakaway torque	A fast curing thread sealant used on coarse threads and pipe fittings up to 75mm thread size. Clearance for gap filling 0.8mm.
	Per-mabond A1044					
Medium strength	Loctite 2431	4102/2700	Blue	365d	140–340bar (2,030.5–4,931.3psi) breakaway torque	Taper thread sealant, non-fluorescing to see oil leaks. Suitable for all taper fittings up to M36.
Low strength	Clayton Dewandre air brake sealant SC1252	4102/2200	White opaque	12h full cure	Maximum seal pressure 29bar (420.6psi)	Seals pipes and plugs against leakage of air, fuels, lubricants and coolants. Hardens to a tough seal resistant to shock and vibration. Easily dismantled.
Low strength	Red Hermetite	4102/0800	Red	-	Resistant to oil	Non-hardening paste jointing for joints regularly opened for servicing.



Subsec-tion	Com-mercial name	Product Number	Colour	Shelf life	Technical data	Comments
Low strength	Loctite 572	4102/1100	White opaque	730d	40–100bar (580.2–1,450.4psi) breakaway torque	Used where slow cure is required to permit component alignment. PTFE (Polytetrafluoroethylene) filler.
Gas-keting medium strength	Loc-tite 509 Gasket Eliminator Flange Sealant	4102/3200	Blue to green	-	72h full strength on steel	Easy disassembly, used as form-in-place gasket. 0.2mm gap filling.
Gas-keting medium strength	Loctite 574 <sup>(1)</sup> Per-mabond A136	4102/1200	Red	730d	2h working strength	Does not creep or relax after curing, no bolt re-tightening is required. Oil resistant. Ideal for formed in-situ gaskets.
Sealant for gas-kets	Loctite FAG 2 / Loctite 5922	4102/2600	Black	365d	Resists pressures up to 345bar (5,003.8psi)	Used to dress new or worn gaskets. Dries slowly, sets to pliable film for easy dismantling.
Rubber jointing compound	Dow corning 781 Loc-tite superflex clear RTV3 EVO-stick standard industrial clear silicone sealant Dun-lop high modulus silicone sealant DP2205	4102/0900	Clear or translucent	270d	16.7bar (242.2psi) tensile strength	A synthetic rubber joint sealant suitable for joints between non-porous surfaces such as glass and metal, metal and metal where relatively large gap filling properties are required. Suitable for vertical and overhead applications under normal atmospheric conditions. Joint movement approx. +/-12.5%. Cure time to 6mm depth in 24h.
Epoxy resin	Loc-tite fast epoxy sealant	4102/2400	Slightly coloured / transparent	-	-	0.05L container requires special bi-mixer (gun) so it is mixed as dispensed, 0.024L is mixed by hand.
Room temperature vulcanising	Loctite 5910, Flange sealant, RTV Silicon	4102/3400	Metallic black paste	-	Dry to touch in 40min	Designed for flange sealing, good resistance to oils and allows high joint movement.

JCB © CONNOR STANMORE - 13/03/2026 07:57.



Subsec-tion	Com-mercial name	Product Number	Colour	Shelf life	Technical data	Comments
Room tempera-ture vul-canising	Loctite 5970	4102/4200	Black	730d	18bar (261.1psi) tensile strength	Used for gaskets. Excellent resistance to engine oils. Typical applications include stamped sheet metal covers (timing covers and oil sumps) where good oil resistance and the ability to withstand high joint-move-ment are required.
Room tempera-ture vul-canising	Loc-tite su-perflex black silicone	4102/2900	Black	270d	16bar (232.1psi) tensile strength	Thixotropic allowing easy application, hori-zontal, vertical and overhead. Seals against water and many solvents.
Room tempera-ture vul-canising	Loctite 5901	4102/3700	Grey	730d	14bar (203.1psi) shear strength	Designed specifically for on line, low pres-sure tests carried out before product be-gins to cure. Product exhibits excellent re-sistance to automotive engine oils. Primari-ly for flange sealing, it withstands high joint-movement requirements.
Room tempera-ture vul-canising	Loctite 5368	4102/3900	Black paste	730d	20bar (290.1psi) tensile strength	Generally used for sealing applications, but also for bonding and for high temperature protection.
Room tempera-ture vul-canising	Loctite 5366	4102/4000	Clear paste	730d	20bar (290.1psi) shear strength	Designed specifically for use as a bond-ing agent to ensure perfect sealing, as well as bonding and protection. Examples are sealing side windows in trains, seal-ing heat sources (heat exchangers and wa-ter heaters) and for protection/insulation of electrical boxes.
Room tempera-ture vul-canising	Hylomar 607	332/D5695	Black paste	540d	40bar (580.2psi) tensile strength	A special purpose adhesive and sealant that can be used for a variety of applica-tions. It has good resistance to oils and aqueous anti-freeze agents, and is particu-larly suitable for high strength applications in odour sensitive environments.
Joining oil pan to bedplate	Loctite 5900	4102/3800	Black paste	730d	14bar (203.1psi) shear strength	JCB Service ONLY. Introduced for joining the oil pan to the bedplate face during ser-vice. High resistance to engine oils. The joint should be clamped to spread the ad-hesive and allowed to cure for 7d before heavy service duty.
Anti-cor-rosive	To mil-itary spec TT-P-1757B 1CY	4102/4300	Yellow	-	Type 1 Class C	Used to coat surfaces of dissimilar metals prior to assembly to prevent corrosion. Zinc chromate containing substance ideal for ap-plication to joints between aluminium and steel to prevent corrosion and seizure. FOR USE ON MILITARY VEHICLES ONLY.
Gas-ke-ting medium strength	Bondloc B555	4102/4500	Clear/ Opaque	-	Full cure time 24h. 50bar (725.2psi) tensile strength	B555 is an anaerobic gasket sealant. It seals close fitting joints between rigid metal faces and flanges. Tensile strength to ISO 6922.

JCB © CONNOR STANMORE - 13/03/2026 07:57.



Subsec-tion	Com-mercial name	Product Number	Colour	Shelf life	Technical data	Comments
Seam sealant	Terolan 3412 AA-25	4102/4600	Light grey	90d	-	Serves as a seam sealant between sheet metal butt and overlap joints (interior seams) on vehicle bodies. Can be cured at temperatures of minimum 140°C (283.8°F) (effective metal temperature) for 15min. The material is applied to electro-dip coated steel sheets.
Direct glazing	Sikaflex 221 (use 4102/4800)	4102/2800	Yellow	-	-	Direct glazing one component polyurethane based adhesive and sealant compound. Tack free time of 50min.
Direct glazing	Sikaflex 252 (use 4102/4700) <sup>(1)</sup>	4102/2300	Black	-	-	A one component polyurethane pre-polymer based sealant. For sealing glass to frames. A mastic sealant which reacts with atmospheric moisture to form a rubber like solid.
Direct glazing	Teroson PU92 CT	4102/4700	-	365d in original packaging	-	The substrates must be clean, dry, oil and grease free. Skin formation time: approx. 20min Cure rate: approx. 4mm/24h
Direct glazing	930 JCB Branded yellow CT	4102/4800	Yellow	365d in original packaging	-	The substrates must be clean, dry, oil and grease free. It can be necessary to roughen the surface or to use a primer/adhesion promoter to provide optimum adhesion. When manufacturing of plastics, external release agents are often used; these agents must be absolutely removed prior. Skin formation time : approx. 20min Cure rate : approx. 4mm/24h
Direct glazing	Terostat 8597 CT	4102/4900	Black	540d in original package	-	Isocyanate free solution. Designed for use without primer or activator. When you use this sealant on operator station, it should be used with Teroson PU 8519P black primer (and Teroson 450 clear adhesion promoter when specified specially). Cross compatible with all OEM / OES / AAM DGX sealants, including MS and PU chemistry (any remaining bead must be fully cured before application).
Silicone sealant - Heat resistant	Si-ka/Ever-build Heat Mate	4102/5100	Black	-	-	High modulus permanently flexible 100% silicone. Temperature resistant up to 300°C (571.6°F). Ideal for sealing industrial and high performance gaskets, oven doors etc.
Gas-ket and sealing	Loctite 510	4102/6100	Opaque pink	-	-	Introduced for Heavy products India (swing motor/ gearbox face).

JCB © CONNOR STANMORE - 13/03/2026 07:57.



## 75 - Consumable Products

16 - Sealant  
00 - General

Subsec-tion	Com-mercial name	Product Number	Colour	Shelf life	Technical data	Comments
Polymer sealant	Terostat MS 930	4102/5200	White	-	-	Silane modified polymer sealant. used on roof panels of power products.
Silicon sealant	Rain-bow - RAL coloured silicone	4102/5300	Yellow	-	-	Contains fungicide. used on roof panels of power products.

(1) This is a non preferred product.



---

# 78 - After Sales

Contents	Page No.
78-24 Maintenance Schedules	
78-24-00 General .....	78-2
78-24-03 Maintenance Intervals .....	78-3
78-24-07 Operator Maintenance Tasks .....	78-4
78-24-10 Service Engineer Maintenance Tasks .....	78-6
78-81 Clothing and Personal Protective Equipment (PPE)	
78-81-00 General .....	78-7
78-93 Special Tools	
78-93-00 General .....	78-8
78-93-03 Parts List .....	78-9
78-96 Units of Measurement	
78-96-00 General .....	78-20

## 24 - Maintenance Schedules

### 00 - General

#### Introduction

The schedules show the service tasks which must be done and their intervals.

The services must be done at either the hourly interval or the calendar equivalent, whichever occurs first.

The intervals given in the schedules must not be exceeded. If the machine is operated under severe conditions (high temperature, dust, water, etc.) shorten the intervals. Where local regulations require more frequent checks, the local regulations intervals should be followed.

**Table 119.**

○	Service task can be completed by a competent operator. Details of how to complete the service task are given in the Operator's Manual.
□	We recommend that a Service Engineer completes the service task. Details of how to complete the service task are given in the Service Manual.



## 03 - Maintenance Intervals

### Introduction

**Table 120.**

<b>Interval (h)</b>	<b>Calendar Equivalent</b>
5	Daily
15	Weekly
125	Three months
250	Six months
500	Yearly
1000	Two years

JCB © CONNOR STANMORE - 13/03/2026 07:57.



## 07 - Operator Maintenance Tasks

### Introduction

**Table 121.**

Component	Task	Daily	Weekly	3 Months
Operator platform	Check (condition)	○	○	○
Operator platform and chassis sliding block <sup>(1)</sup>	Check (condition and grease)	○	○	○
Safety labels	Check (condition)	○	○	○
Hydraulic hoses	Check (condition)	○	○	○
Hydraulic oil	Check (level)	○	○	○
Hydraulic oil	Check (condition)	○	○	○
Hydraulic oil	Check (leaks)	○	○	○
Ventilation system - hydraulic tank	Check (operation)	○	○	○
Battery electrolyte	Check (level)	○	○	○
Battery electrolyte	Check (leaks)	○	○	○
Battery leads	Check (condition)	○	○	○
All electrical cables and conductors	Check (condition)	○	○	○
AC power to platform and charger cables	Visual inspection/check (operation)	○	○	○
Equipotential bond cables damage <sup>(2)</sup>	Check (condition)		○	○
Welds	Check (condition)	○	○	○
Machine damage, missing parts	Check (condition)	○	○	○
Fasteners	Check (condition)	○	○	○
Lateral guard rail	Check (condition)	○	○	○
Wheel nut	Check (condition)	○	○	○
Wheel rim and tyre	Check (condition)	○	○	○
Scissor base slider	Grease	○	○	○
Tilt sensor	Check (condition)	○	○	○



Component	Task	Daily	Weekly	3 Months
Pothole protection system	Check (condition)	○	○	○
Lanyard anchor point on platform	Check (condition)	○	○	○
Ground controller				
Emergency stop	Check (operation)	○	○	○
Platform raise and lower functions	Check (operation)	○	○	○
Platform emergency lowering	Check (operation)	○	○	○
Ignition switch	Check (operation)	○	○	○
Platform controller				
Emergency stop	Check (operation)	○	○	○
Platform raise and lower functions	Check (operation)	○	○	○
Horn	Check (operation)	○	○	○
Steering	Check (operation)	○	○	○
Drive and brake	Check (operation)	○	○	○
General				
Limited driving speed (with platform lifted and stowed)	Check (operation)	○	○	○
Tilt sensor	Check (operation)	○	○	○
Pothole protection system	Check (operation)	○	○	○
Ventilation system- hydraulic tank	Check (operation)	○	○	○
AC power to platform and charger cables	Check (operation)	○	○	○

(1) Check grease, apply if required.

(2) Check condition and replace if damaged (yellow/green and braided equipotential bond earthing cables).

JCB © CONNOR STANMORE - 13/03/2026 07:57.



## 10 - Service Engineer Maintenance Tasks

### Introduction

Table 122.

Component	Task	6 Months	Yearly	2 Years
Hydraulic oil	Replace			<input type="checkbox"/>
Hydraulic return filter	Replace		<input type="checkbox"/>	<input type="checkbox"/>
Vent filter - hydraulic tank	Check (condition)	<input type="checkbox"/>	<input type="checkbox"/>	<input type="checkbox"/>
Vent filter - hydraulic tank	Replace			<input type="checkbox"/>
Wheel Motor Oil <sup>(1)</sup>	Replace		<input type="checkbox"/>	<input type="checkbox"/>
Equipotential bond cables resistance <sup>(2)</sup>	Check (condition)	<input type="checkbox"/>	<input type="checkbox"/>	<input type="checkbox"/>
Scissor base & basket sliders	Check (condition)		<input type="checkbox"/>	<input type="checkbox"/>
Lift ram(s)	Grease	<input type="checkbox"/>	<input type="checkbox"/>	<input type="checkbox"/>
Steer pivots	Grease	<input type="checkbox"/>	<input type="checkbox"/>	<input type="checkbox"/>
Scissor basket slider	Grease	<input type="checkbox"/>	<input type="checkbox"/>	<input type="checkbox"/>
Scissor arm bush	Check (condition)		<input type="checkbox"/>	<input type="checkbox"/>
General				
Overload system	Check (operation)	<input type="checkbox"/>	<input type="checkbox"/>	<input type="checkbox"/>
Hydraulic system pressure	Check (settings)	<input type="checkbox"/>	<input type="checkbox"/>	<input type="checkbox"/>
Hydraulic system functional test	Check (operation)	<input type="checkbox"/>	<input type="checkbox"/>	<input type="checkbox"/>
Overload test	Check (operation)	<input type="checkbox"/>	<input type="checkbox"/>	<input type="checkbox"/>
AC power to platform and charger cables	Check (operation)	<input type="checkbox"/>	<input type="checkbox"/>	<input type="checkbox"/>
Calibration	Check	<input type="checkbox"/>	<input type="checkbox"/>	<input type="checkbox"/>

(1) An initial oil change should be made after the first 50 Hours only, to be completed by your JCB Distributor.

(2) Check resistance from ground to the protective earth in the on board charger plug to be no greater than 0.2 ohms.



## **81 - Clothing and Personal Protective Equipment (PPE)**

### **00 - General**

#### **Introduction**

Do not wear loose clothing or jewellery that can get caught on controls or moving parts. Wear protective clothing and personal safety equipment issued or called for by the job conditions, local regulations or as specified by your employer.

## **93 - Special Tools**

### **00 - General**

#### **Introduction**

The tools shown are the special tools required for completing the procedures described in this manual. These tools are available from JCB Service or in some instances can be manufactured locally.

The tools are divided into three categories:

- Special Tool = Only available from JCB.
- Recommended Tool = Available from JCB but other tool manufacturers/suppliers may offer a tool with the same characteristics.
- General Tool = A tool which is widely available.

Tools other than those listed will be required. It is expected that such general tools will be available in any well equipped workshop or be available locally from any good tool supplier.

Before you start work, make sure that all safety precautions are observed in accordance with the information contained within the relevant support documentation.



## 03 - Parts List

## Introduction

Introduction ..... 78-9  
Component Identification ..... 78-11

### 01 - Machine

Tool Category	Part No.	Description	Qty.	Comments
Special Tool	400/J2673	Tilt sensor calibration lead	1	

### 27 - Driveline

Tool Category	Part No.	Description	Qty.	Comments
Recommended Tool		Wheel Chock - JC/405217	6	
General Tool	334/F1285	Forklift Jack	1	
Special Tool	400/K4721	Puller Tool	1	

### 30 - Hydraulic System

Tool Category	Part No.	Description	Qty.	Comments
Special Tool	892/00167	Ram Protection Sleeve (90mm rod diameter)	1	
Special Tool	892/00334	Ram Seal Installation Tool	1	
Special Tool	892/01016	Ram Protection Sleeve (25mm rod diameter)	1	
Special Tool	892/01017	Ram Protection Sleeve (30mm rod diameter)	1	
Special Tool	892/01018	Ram Protection Sleeve (40mm rod diameter)	1	
Special Tool	892/01019	Ram Protection Sleeve (50mm rod diameter)	1	
Special Tool	892/01020	Ram Protection Sleeve - Slew (50mm rod diameter)	1	
Special Tool	892/01021	Ram Protection Sleeve (60mm rod diameter)	1	
Special Tool	892/01022	Ram Protection Sleeve - Slew (60mm rod diameter)	1	
Special Tool	892/01023	Ram Protection Sleeve (65mm rod diameter)	1	
Special Tool	892/01024	Ram Protection Sleeve (70mm rod diameter)	1	
Special Tool	892/01025	Ram Protection Sleeve (75mm rod diameter)	1	
Special Tool	892/01026	Ram Protection Sleeve (80mm rod diameter)	1	
Special Tool	892/01027	Ram Seal Assembly Tool	1	
Special Tool	892/01255	Hydraulic Flushing Rig	1	



Tool Category	Part No.	Description	Qty.	Comments
Recommended Tool	892/01268	Digital Pressure Gauge 0-400 bar	1	
Special Tool	892/01271	Hose for Pressure Gauge	1	
Special Tool	998/11051	Digital Hydraulic Pressure Test Kit	1	

### 33 - Electrical System

Tool Category	Part No.	Description	Qty.	Comments
General Tool	333/H5664	Meter (hydrometer)	1	
Special Tool	400/J3606	6V Battery Lifting Tool	1	
Special Tool	400/K9854	12V Battery Lifting Tool	2	
Special Tool	728/H5409	Data Link Adaptor (DLA 2.0) Kit	1	
General Tool	892/00349	Wiring Crimp Tool	1	
General Tool	892/00350	Butane Heater	1	

## Component Identification

Recommended Tool - - Wheel Chock - JC/405217



General Tool - 333/H5664 - Meter (hydrometer)



General Tool - 334/F1285 - Forklift Jack



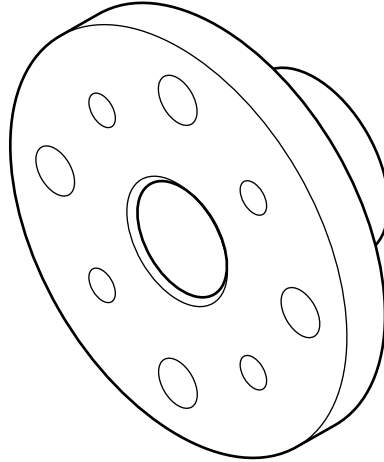
Special Tool - 400/J2673 - Tilt sensor calibration lead



Special Tool - 400/J3606 - 6V Battery Lifting Tool



**Special Tool - 400/K4721 - Puller Tool**

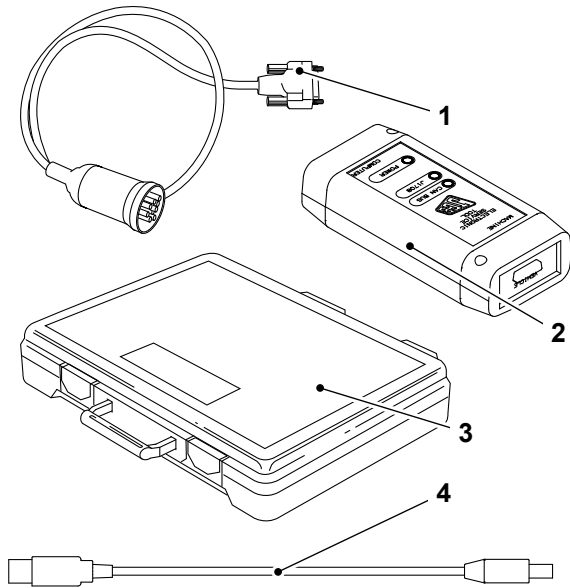


Use with M14 Bolts (x4), 1315/3610D, M20 Bolt (x1)  
1315/3814D

**Special Tool - 400/K9854 - 12V Battery Lifting Tool**

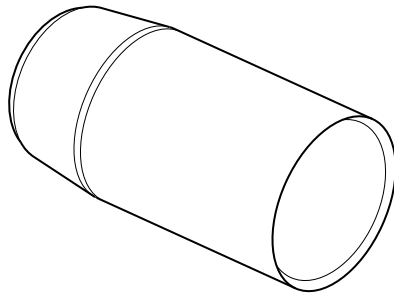


**Special Tool - 728/H5409 - Data Link Adaptor (DLA 2.0) Kit**

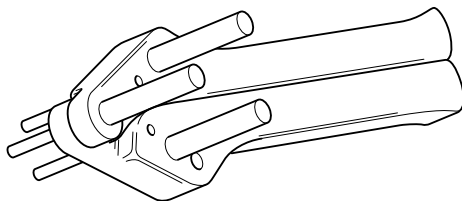


Item	Part No.	Description	Qty.
1		Interconnecting cable, DLA to machine ECU diagnostics socket.	1
2		Data Link Adaptor (DLA 2.0), enables data exchange between the machine ECU (Electronic Control Unit) and a laptop PC loaded with the applicable diagnostics software.	1
3		Kit carrying case.	1
4		Interconnecting cable, DLA to laptop PC.	1

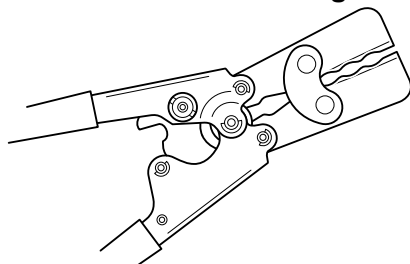
**Special Tool - 892/00167 - Ram Protection Sleeve (90mm rod diameter)**



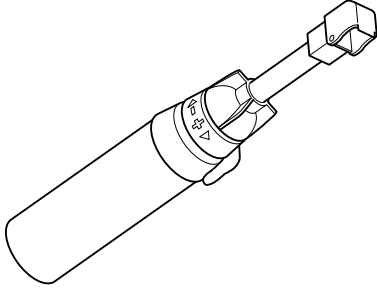
**Special Tool - 892/00334 - Ram Seal Installation Tool**



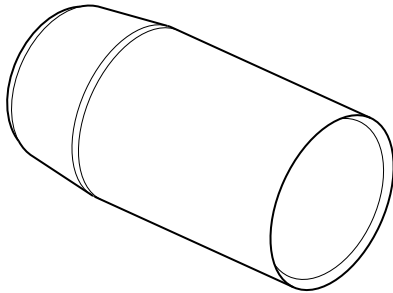
**General Tool - 892/00349 - Wiring Crimp Tool**



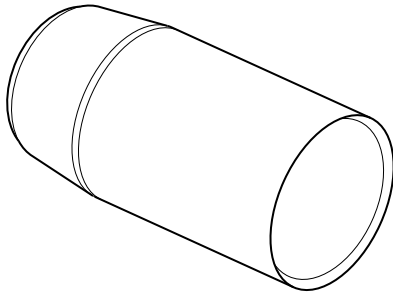
**General Tool - 892/00350 - Butane Heater**



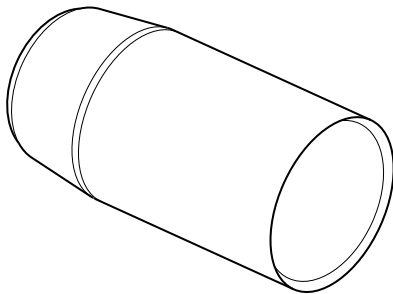
**Special Tool - 892/01016 - Ram Protection Sleeve (25mm rod diameter)**



**Special Tool - 892/01017 - Ram Protection Sleeve (30mm rod diameter)**

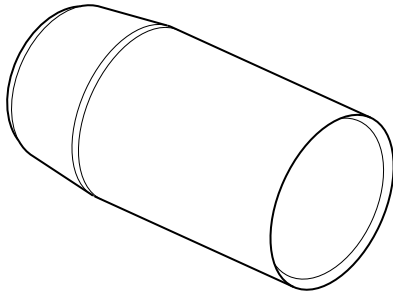


**Special Tool - 892/01018 - Ram Protection Sleeve (40mm rod diameter)**

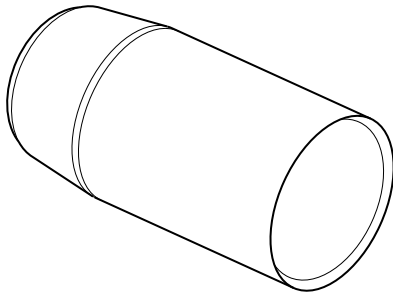


JCB © CONNOR STANMORE - 13/03/2026 07:57.

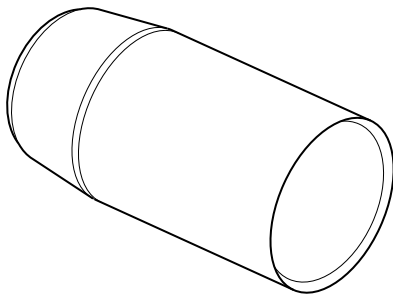
**Special Tool - 892/01019 - Ram Protection Sleeve (50mm rod diameter)**



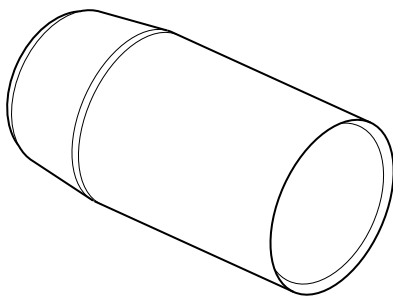
**Special Tool - 892/01020 - Ram Protection Sleeve - Slew (50mm rod diameter)**



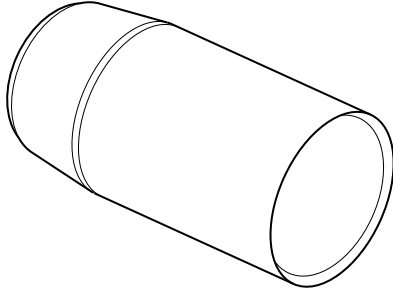
**Special Tool - 892/01021 - Ram Protection Sleeve (60mm rod diameter)**



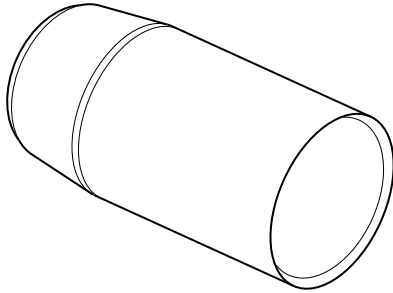
**Special Tool - 892/01022 - Ram Protection Sleeve - Slew (60mm rod diameter)**



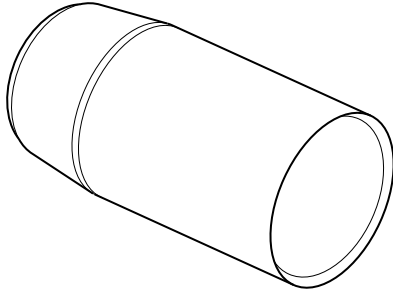
**Special Tool - 892/01023 - Ram Protection Sleeve (65mm rod diameter)**



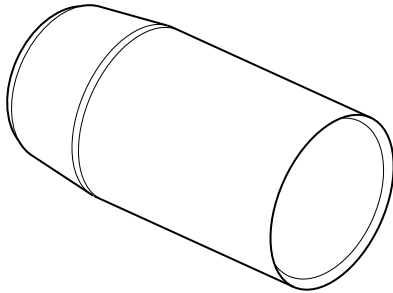
**Special Tool - 892/01024 - Ram Protection Sleeve (70mm rod diameter)**



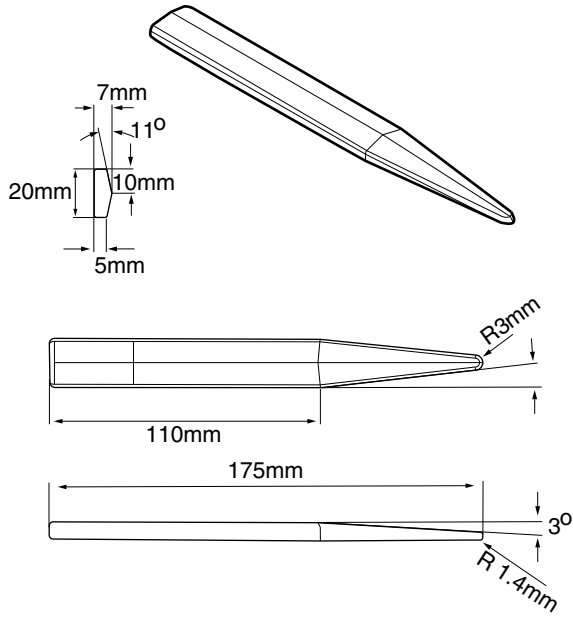
**Special Tool - 892/01025 - Ram Protection Sleeve (75mm rod diameter)**



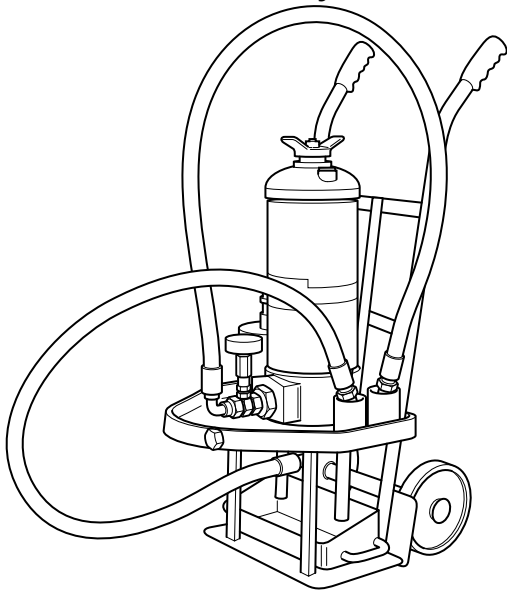
**Special Tool - 892/01026 - Ram Protection Sleeve (80mm rod diameter)**



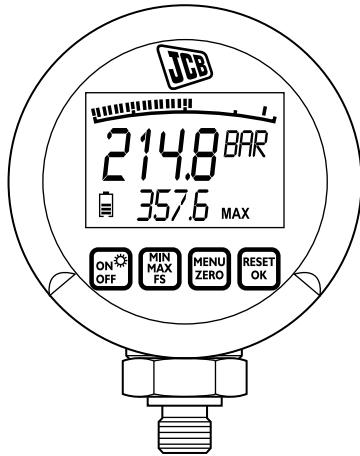
**Special Tool - 892/01027 - Ram Seal Assembly Tool**



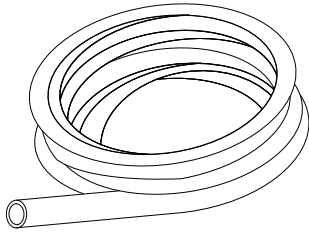
**Special Tool - 892/01255 - Hydraulic Flushing Rig**



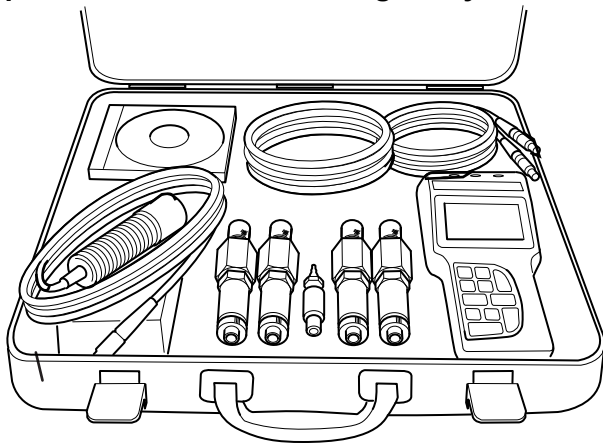
**Recommended Tool - 892/01268 - Digital Pressure Gauge 0-400 bar**



**Special Tool - 892/01271 - Hose for Pressure Gauge**



**Special Tool - 998/11051 - Digital Hydraulic Pressure Test Kit**



Item	Part No.	Description	Qty.
1	998/11052	Hand Held 4-Channel ServiceMaster Unit	1
2	998/11053	SensoWin Software Kit and PC Cable	1
3	998/11054	Equipment Case	1
4	998/11055	0-600 Bar Pressure Transducer	2
5	998/11056	0-100 Bar Pressure Transducer	2
6	998/11057	RPM Tachometer (includes fixed cable, 2 metres)	1
7	998/11058	5 Metre Connecting Cable	1
8	998/11059	M16 Metric Adaptors for Test Points	4
9	998/11060	400mm Test Hose 90° HSP to M16	2
10	998/11061	400mm Test Hose Straight HSP to M16	2

## 96 - Units of Measurement

### 00 - General

#### Technical Data

The standard units of measurement used by JCB are listed below together with the formula for conversion for countries using non metric standards.

#### Standard Units

**Table 123. Force**

Measurement (unit)	Convert to	Multiply by
Newton (N)	Kilogram force (kgf)	0.102
	Pound force (lbf)	0.225

**Table 124. Length**

Measurement (unit)	Convert to	Multiply by
Millimetre (mm)	Inch (in)	0.0394
Metre (m)	Feet (ft)	3.281
	Yard (yd)	1.094
Kilometre (km)	Mile (mile)	0.621

**Table 125. Mass**

Measurement (unit)	Convert to	Multiply by
Gram (g)	Ounce (oz)	0.035
Kilogram (kg)	Pound (lb)	2.205
Tonne	Ton	0.984

**Table 126. Speed**

Measurement (unit)	Convert to	Multiply by
Kilometre/Hour (km/h)	mile/hour (mph)	0.621
Metre/Second (m/s)	feet/second (ft/s)	3.281

**Table 127. Volume**

Measurement (unit)	Convert to	Multiply by
Cubic Centimetre (cm <sup>3</sup> )	Cubic Inch (in <sup>3</sup> )	0.061
Cubic Metre (m <sup>3</sup> )	Cubic Foot (ft <sup>3</sup> )	35.315
	Cubic Yard (yd <sup>3</sup> )	1.308

Measurement (unit)	Convert to	Multiply by
Millilitre (ml)	Fluid ounce (fl oz)	0.035
Litre (l)	UK Gallon	0.220
	US Gallon	0.264

**Table 128. Flow**

Measurement (unit)	Convert to	Multiply by
Litre/Minute (L/m)	UK Gal- lon/Minute	0.220
	US Gal- lon/Minute	0.264

**Table 129. Area**

Measurement (unit)	Convert to	Multiply by
Square Millimetre (mm <sup>2</sup> )	Square Inch (in <sup>2</sup> )	0.0015
Square Metre (m <sup>2</sup> )	Square Foot (ft <sup>2</sup> )	10.764
	Square Yard (yd <sup>2</sup> )	1.196

**Table 130. Torque**

Measurement (unit)	Convert to	Multiply by
Newton metre (Nm)	Pound force foot (lb f ft)	0.7376

**Table 131. Pressure**

Measurement (unit)	Convert to	Multiply by
Bar	Pound force/ inch <sup>2</sup> (psi)	14.5

**Table 132. Temperature**

Measurement (unit)	Convert to	Formula
Degrees Celsius (°C)	Degrees Fahrenheit (°F)	Multiply by 9, Divide by 5, Add 32

**Table 133. Power**

Measurement (unit)	Convert to	Multiply by
KiloWatt (kW)	Horsepower (hp)	1.341



**Table 134. Time**

Measurement (unit)
Second (s)
Minute (min)
Hour (h)

**Table 135. Current**

Measurement (unit)
Ampere (A)

**Table 136. Voltage**

Measurement (unit)
Volt (V)

**Table 137. Noise Levels**

Measurement (unit)
Sound pressure level (LpA)
Sound power level (LwA)

JCB © CONNOR STANMORE - 13/03/2026 07:57.