



OPERATOR'S MANUAL

**MOBILE ELEVATING WORK PLATFORM
A45EH**

EN - 9841/9000 ISSUE 5 - 12/2025

THIS MANUAL SHOULD ALWAYS STAY WITH THE MACHINE

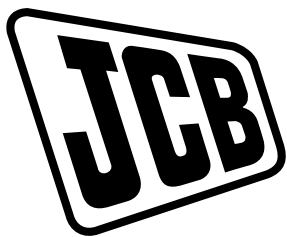

OPERATOR'S MANUAL

MOBILE ELEVATING WORK PLATFORM
A45EH



EN - 9841/9000 - ISSUE 5 - 12/2025

This manual contains original instructions, verified by the manufacturer (or their authorized representative).

Copyright 2025 © JCB SERVICE
All rights reserved. No part of this publication may be reproduced, stored in a retrieval system, or transmitted in any form or by any other means, electronic, mechanical, photocopying or otherwise, without prior permission from JCB SERVICE.

www.jcb.com

Foreword

The Operator's Manual

 You and others can be killed or seriously injured if you operate or maintain the machine without first studying the Operator's Manual. You must understand and follow the instructions in the Operator's Manual. If you do not understand anything, ask your employer or JCB dealer to explain it.

Do not operate the machine without an Operator's Manual, or if there is anything on the machine you do not understand.

Treat the Operator's Manual as part of the machine. Keep it clean and in good condition. Replace the Operator's Manual immediately if it is lost, damaged or becomes unreadable.

Machine Delivery and Installation

Even if you have operated this type of equipment before, it is very important that your new machines operations and functions are explained to you by a JCB Dealer Representative following delivery of your new machine.

Following the installation you will know how to gain maximum productivity and performance from your new product.

Please contact your local JCB dealer if the Installation Form (included in this manual) has not yet been completed with you.

Your local JCB Dealer is



Contents	Page No.
Acronyms Glossary	vi
Introduction	
About this Manual	
Model and Serial Number	1
Using the Manual	1
Left-Hand Side, Right-Hand Side	1
Cross References	2
Location of Manual	2
Safety	
Safety - Yours and Others	3
Safety Warnings	3
General Safety	3
Clothing and Personal Protective Equipment (PPE)	4
About the Product	
Introduction	
General	5
Name and Address of the Manufacturer	5
Product Compliance	5
Description	
General	6
Intended Use	6
Log Moving/Object Handling	6
Danger Zone	6
Main Component Locations	7
Product and Component Identification	
Machine	8
Engine	8
Safety Labels	
General	10
Safety Label Identification	10
Operation	
Introduction	
General	15
Operating Safety	
General	16
Worksite Safety	17
Risk Assessment	18
Walk-Around Inspection	
General	20
Entering and Leaving the Platform	
General	22
Service Disconnect	
General	24
Starting the Machine	
General	26
Stopping and Parking	
General	27



Instruments
 Instrument Panel 28

Getting the Machine Moving
 General 32

Slopes
 General 34
 Driving on Slopes 34

Driving the Machine
 General 38

Operating Levers/Pedals
 Basic Controls 40

Working with the Platform
 General 41

Auxiliary Electrics
 General 44

Moving a Disabled Machine
 General 51

Lifting the Product
 General 54
 Lifting Points 55

Transporting the Product
 General 57
 Loading onto the Transporting Vehicle 57
 Tie Down Points 58

Operating Environment
 General 61
 Operating in Low Temperatures 61
 Operating in High Temperatures 61

Refuelling
 General 62
 Filling the Tank 62

Attachments
 Working with Attachments
 Attachments for your Machine 63

Reflector
 General 64

Half Mesh
 General 65

Console Shield
 General 66

Worklight
 General 67

Pipe Cradle Post
 General 68

Safety Strut
 General 72

Wheel Nut Indicator
 General 73

Smart White Alarm
 General 74

JCB © CONNOR STANMORE - 13/03/2026 07:54.



Preservation and Storage

Cleaning
General 75

Storage
General 77
Put into Storage 77
During Storage 77
Take out of Storage 78

Maintenance

Introduction
General 79
Owner/Operator Support 79
Service/Maintenance Agreements 80
Obtaining Spare Parts 80

Maintenance Safety
General 81
Fluids and Lubricants 82

Maintenance Schedules
General 85
How to Use the Maintenance Schedules 85
Maintenance Intervals 85
Operator Maintenance Tasks 85
Service Engineer Maintenance Tasks 87

Maintenance Positions
General 91

Service Points
General 92

Access Apertures
General 94
Battery Cover 94
Engine Compartment Cover 95
Hydraulic Compartment Cover 96
Front Cover 97
Rear Cover 98

Body and Framework
General 99

Controls
Check (Operation) 100

Safety Equipment
Check (Operation) 106

Engine
General 110
Oil 112
Front End Accessory Drive (FEAD) Belt 113
Exhaust 115

Air Filter
General 116
Outer Element 116
Dust Valve 117

Fuel System
General 118



Pre-Filter Element 119

Engine Fuel Filter 119

Water Separator 120

Cooling System

 General 122

 Coolant 122

 Cooling Pack 123

Brakes

 General 124

Steering System

 Steering 125

Wheels

 Check (Condition) 126

Tyres

 General 128

Hydraulic System

 Oil 129

Electrical System

 General 130

 Battery 131

 Service Disconnect 137

 Fuses 137

 Relays 140

Technical Data

 Introduction

 General 145

 Static Dimensions

 Dimensions 146

 Weights 147

 Visibility Diagrams 148

 Performance Dimensions

 General 151

 Boom Dimensions and Performance 153

 Noise Emissions

 Noise Data 154

 Vibration Emissions

 Vibration Data 155

 Fluids, Lubricants and Capacities

 General 156

 Fuel 156

 Coolant 158

 Torque Values

 Data 159

 Electrical System

 General 160

 Fuses 160

 Relays 162

 Engine

 Data 164

 Hydraulic System

 General 165



Wheels and Tyres	
General	166
Fault-Finding	
General	167
Declaration of Conformity	
General	168
Data	168
Warranty Information	
Service Record Sheet	170

JCB © CONNOR STANMORE - 13/03/2026 07:54.



Acronyms Glossary

AC	Alternating Current
BDI	Battery Discharge Indicator
DC	Direct Current
ECU	Electronic Control Unit
ESOS	Engine Shut-Off Solenoid
LED	Light Emitting Diode
MEWP	Mobile Elevating Work Platform
PIN	Product Identification Number
PPE	Personal Protective Equipment
RCBO	Residual Current Breaker with Over-Current
RPM	Revolutions Per Minute

JCB © CONNOR STANMORE - 13/03/2026 07:54.

Introduction About this Manual

Model and Serial Number

This manual provides information for the following model(s) in the JCB machine range:

Table 1.

Model	VIN Prefix.
A45EH	RAJA5044
	RAJA5144
	RAJA5A44
	RAJA5B44

Using the Manual

The Quick Start Guide or Quick Reference Guide (if supplied) with the machine does not replace the Operator's Manual. You must read all the disclaimers and safety instructions in the Operator's Manual before initially operating the machine.

This Operator's Manual is arranged to give you a good understanding of the machine and its safe operation. It also contains maintenance and technical data.

Read this manual from the front to the back before you use the machine for the first time, even if you have used machines of a similar/same type before as the technical specification, systems and controls of the machine may have changed. Particular attention must be given to all the safety aspects of operating and maintaining the machine.

If there is anything you are not sure about, ask your JCB dealer or employer. Do not guess, you or others could be killed or seriously injured.

The general and specific warnings in this section are repeated throughout the manual. Read all the safety statements regularly, so you do not forget them. Remember that the best operators are the safest operators.

The illustrations in this manual are for guidance only. Where the machines are different, the text and / or the illustration will specify.

The manufacturer's policy is one of continuous improvement. The right to change the specification of the machine without notice is reserved. No responsibility will be accepted for discrepancies which may occur between specifications of the machine and the descriptions contained in this manual.

All the optional equipment included in this manual may not be available in all territories.

Left-Hand Side, Right-Hand Side

In this manual, 'left' and 'right' refer to your left and right sides when you are standing on the platform facing the platform control.

[Refer to: Main Component Locations \(Page 7\).](#)

Figure 1.

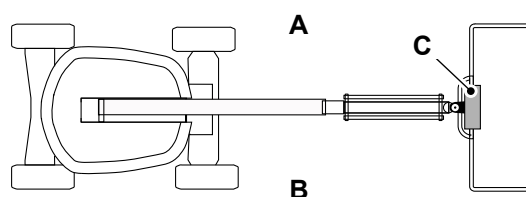

A Right - Engine side

B Left - Control side

C Platform control

Cross References

In this manual, cross references are made by presenting the subject title in blue (electronic copy only). The number of the page upon which the subject begins is indicated within the brackets. For example:
[Refer to: Cross References \(Page 2\)](#).

Location of Manual

The operator's manual is kept in to a 'document box' in the center of platform under the controls. The manual should always be put back in its box after use.

Safety

Safety - Yours and Others

All machinery can be hazardous. When a machine is correctly operated and maintained, it is a safe machine to work with. When it is carelessly operated or poorly maintained it can become a danger to you (the operator) and others.

In this manual and on the machine you will find warning messages, you must read and understand them. They inform you of potential hazards and how to avoid them. If you do not fully understand the warning messages, ask your employer or JCB dealer to explain them.

Safety is not just a matter of responding to the warnings. All the time you are working on or with the machine you must be thinking of what hazards there might be and how to avoid them.

Do not work with the machine until you are sure that you can control it.

Do not start any work until you are sure that you and those around you will be safe.

If you are not sure of anything, about the machine or the work, ask someone who knows. Do not assume anything.

Remember:

- Be careful.
- Be alert.
- Be safe.

Safety Warnings

In this manual there are safety notices. Each notice starts with a signal word. The signal word meanings are given below.

The signal word 'DANGER' indicates a hazardous situation which, if not avoided, will result in death or serious injury.

The signal word 'WARNING' indicates a hazardous situation which, if not avoided, could result in death or serious injury.

The signal word 'CAUTION' indicates a hazardous situation which, if not avoided, could result in minor or moderate injury.

The signal word 'Notice' indicates a hazardous situation which, if not avoided, could result in machine damage.

The safety alert system symbol (shown) also helps to identify important safety messages in this manual. When you see this symbol your safety is involved, carefully read the message that follows.

Figure 2. The safety alert system symbol



General Safety

Training

To operate the machine safely you must have received the appropriate training. The operator's manual instructs you on the machine, its controls and its safe operation; it is not a training manual. Ensure that you receive the correct training before operating the machine. Failure to do so will result in incorrect operation of the machine and you will be putting yourself and others at risk. You must abide by all local site regulations. Make sure that you and your machine comply with relevant local laws and jobsite requirements – it is your responsibility.

Care and Alertness

All the time you are working with or on the machine, take care and stay alert.

Alcohol and Drugs

It is extremely dangerous to operate or work on machines when under the influence of drugs or alcohol. Do not consume alcoholic drinks or take drugs before or while operating any machinery. Medicines could reduce your ability to control the machine safely due to their possible side effects such as drowsiness, dizziness, loss of touch, blurred vision etc. This list is not totally exhaustive, consult your doctor if you are unsure.

Feeling Unwell

Do not attempt to operate the machine if you are feeling unwell. By doing so you could be a danger to yourself and those you work with. If you begin to feel unwell during operation stop using the machine immediately and seek help.

Hillsides

Operating the machine on hillsides can be dangerous if the correct precautions are not taken. Ground conditions can be changed by rain, snow, ice etc. Check the site carefully. When applicable, keep all attachments low to the ground.

Mobile Phones

Switch off your mobile phone before entering an area with a potentially explosive atmosphere. Sparks in such an area could cause an explosion or fire resulting in death or serious injury.

Raised Equipment

Never walk or work under raised equipment unless it is supported by a mechanical device. Equipment which is supported only by a hydraulic device can drop and injure you if the hydraulic system fails or if the control is operated (even with the motor stopped).

Make sure that no-one goes near the machine while you install or remove the mechanical device.

Raised Machine

Never position yourself or any part of your body under a raised machine which is not correctly supported. If the machine moves unexpectedly you could become trapped and suffer serious injury or be killed.

Lightning

Lightning can kill you. Do not use the machine if there is lightning in your area.

Machine Modifications

This machine is manufactured in compliance with prevailing legislative requirements. It must not be altered in any way which could affect or invalidate its compliance. For advice consult your JCB dealer.

Clothing and Personal Protective Equipment (PPE)

Do not wear loose clothing that can get caught on controls or moving or rotating machine parts. Keep cuffs fastened. Do not wear a necktie or scarf. Keep long hair restrained. Remove rings, watches and personal jewellery. Wear protective clothing and personal safety equipment issued or called for by the job conditions, local regulations or as specified by your employer. It is recommended to put on safety harnesses at all times when operating the machine.

About the Product

Introduction

General

Before you start using the machine, you must know how the machine operates. Use this part of the manual to identify each control lever, switch, gauge, button and pedal. Do not guess, if there is anything you do not understand, ask your JCB dealer.

Name and Address of the Manufacturer

JCB Access Limited, Lakeside Works, Rocester, Uttoxeter, United Kingdom, ST14 5JP.

Product Compliance

Your JCB product was designed to comply with the laws and regulations applicable at the time of its manufacture for the market in which it was first sold. In many markets, laws and regulations exist that require the owner to maintain the product at a level of compliance relevant to the product when first produced. Even in the absence of defined requirements for the product owner, JCB recommend that the product compliance be maintained to ensure safety of the operator and exposed persons and to ensure the correct environmental performance. Your product must not be altered in any way which could affect or invalidate any of these requirements. For advice consult your JCB dealer.

For its compliance as a new product, your JCB and some of its components may bear approval numbers and markings, and may have been supplied with a Declaration/Certificate of Conformity. These markings and documents are relevant only for the country/region in which the product was first sold to the extent that the laws and regulations required them.

Re-sales and import/export of products across territories with different laws and regulations can cause new requirements to become relevant for which the product was not originally designed or specified. In some cases, pre owned products irrespective of their age are considered new for the purposes of compliance and may be required to meet the latest requirements which could present an insurmountable barrier to their sale/use.

Despite the presence of any compliance related markings on the product and components, you should not assume that compliance in a new market will be possible. In many cases it is the person responsible for import of a pre owned product into a market that becomes responsible for compliance and who is also considered the manufacturer.

JCB may be unable to support any product compliance related enquiry for a product which has been moved out of the legislative country/region where it was first sold, and in particular where a product specification change or additional certification would have been required in order for the product to be in compliance.

Description

General

Important Note: This equipment is compliant with Class A of CISPR16/EN55016 and may cause interference in excess of limits required in residential areas.

This machine is a self propelled MEWP (Mobile Elevating Work Platform) with a wheeled undercarriage. A articulated and telescopic boom is mounted to a revolving upper structure.

Intended Use

The machine is intended to lift personnel with their tools, and position them at a level of working height safely. The machine can be used to reach areas located above machinery or equipment positioned at ground level by use of the extending structure and platform.

The machine is intended to be used for the applications and in the environmental conditions as described in this manual. Use in any other way not described in the manual is considered contrary to intended use of this machine.

The machine is not intended for use in mining and quarrying applications, in demolition activities, forestry, any use underground, or in any kind of explosive atmosphere. This is not an exhaustive list. For any activity not described here, it is recommended that a risk assessment must be done prior to operation.

If the machine is to be used in applications where there is a high silica concentration, risk due to materials containing asbestos or similar hazards, additional protective measures such as the use of PPE (Personal Protective Equipment) may be required.

The machine should not be operated by any person who does not have an appropriate level of qualification, training or experience of use of this type of machine.

Prior to use of the machine, its suitability (size, performance, specification etc.) should be considered with regards to the intended application and any relevant hazards that may exist. Contact your JCB dealer for support in determining the appropriate JCB machine, attachment and any optional equipment that is suitable for the application and environment.

The machine is not intended to be used as a towing machine. Do not attach trailers or other towing devices to the machine.

Log Moving/Object Handling

Do not use the machine to move or handle logs or other objects. You could cause serious injury to yourself and damage to the machine. Do not use the machine as a crane. Do not overload the platform with tools or equipment.

Refer to: [Technical Data \(Page 145\)](#). For more information, contact your JCB dealer.

Danger Zone

The danger zone is any zone within and/or around the machinery in which a person is subject to a risk to their health or safety. During operation of the machine, keep all persons out of the danger zone. Persons in the danger zone could be injured.

Before you do a maintenance task, make the product safe.

Refer to: [Maintenance Positions \(Page 91\)](#).

Main Component Locations

Figure 3.

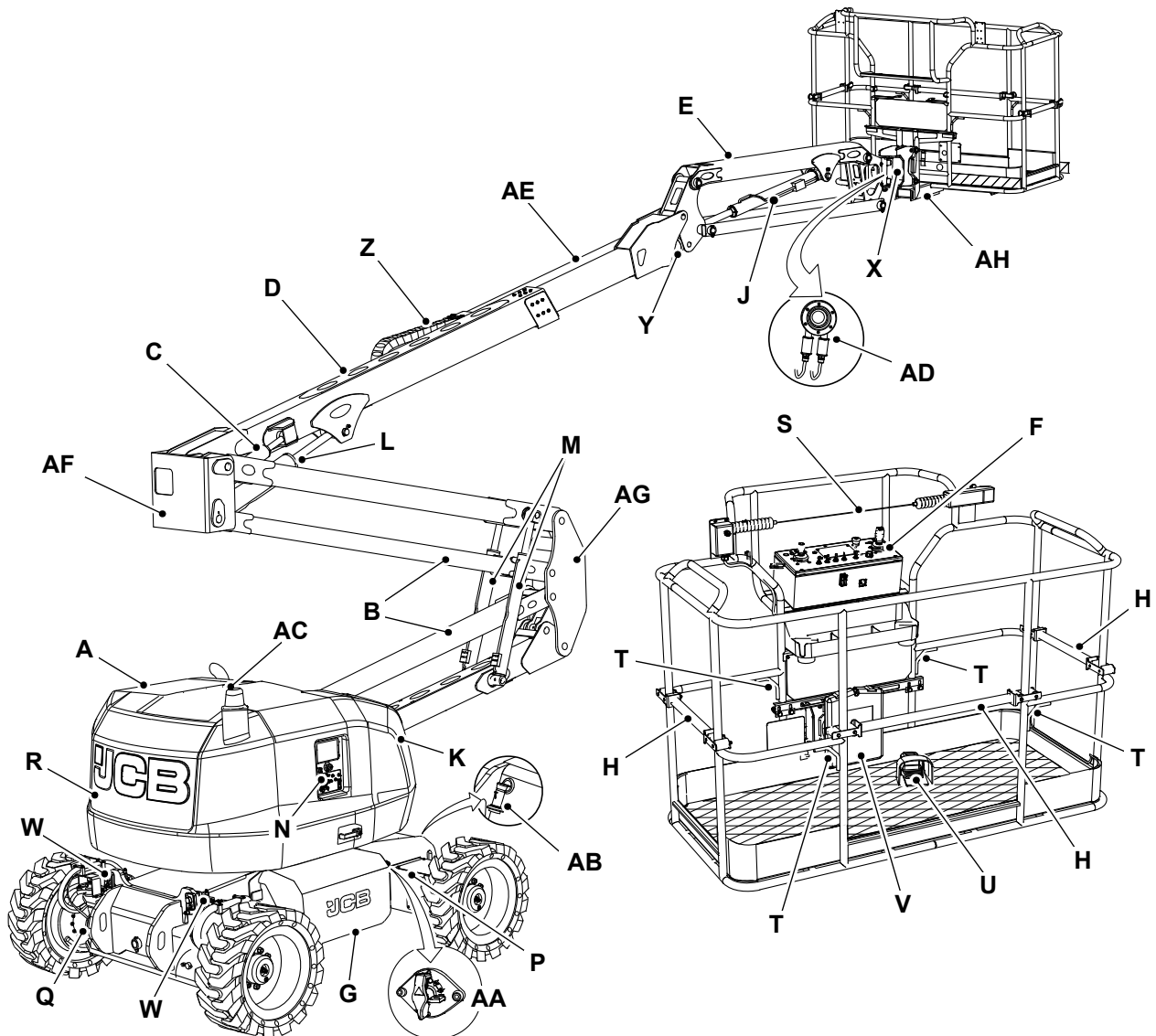

- | | | | |
|-----------|-------------------------------|-----------|--------------------------------|
| A | Engine canopy | B | Articulated boom |
| C | Lower leveling cylinder | D | Telescopic boom (stage 1) |
| E | Jib | F | Platform controller |
| G | Battery compartment | H | Sliding tubes |
| J | Jib lift cylinder | K | Control side canopy |
| L | Telescopic boom lift cylinder | M | Articulated boom lift cylinder |
| N | Base control panel | P | Under carriage |
| Q | Front axle | R | Counter weight |
| S | Secondary guarding system | T | Safety harness anchorage point |
| U | Foot pedal switch | V | Documents box |
| W | Oscillating axle cylinder | X | Platform rotate actuator |
| Y | Upper leveling cylinder | Z | Drag chain |
| AA | Battery isolator | AB | Battery charging point |
| AC | Beacon | AD | Load cell |
| AE | Telescopic boom (stage 2) | AF | Boom front knuckle |
| AG | Boom rear knuckle | AH | Platform carrier |

Product and Component Identification

Machine

Your machine has an identification plate as shown. Refer to Figure 4.

Figure 4.

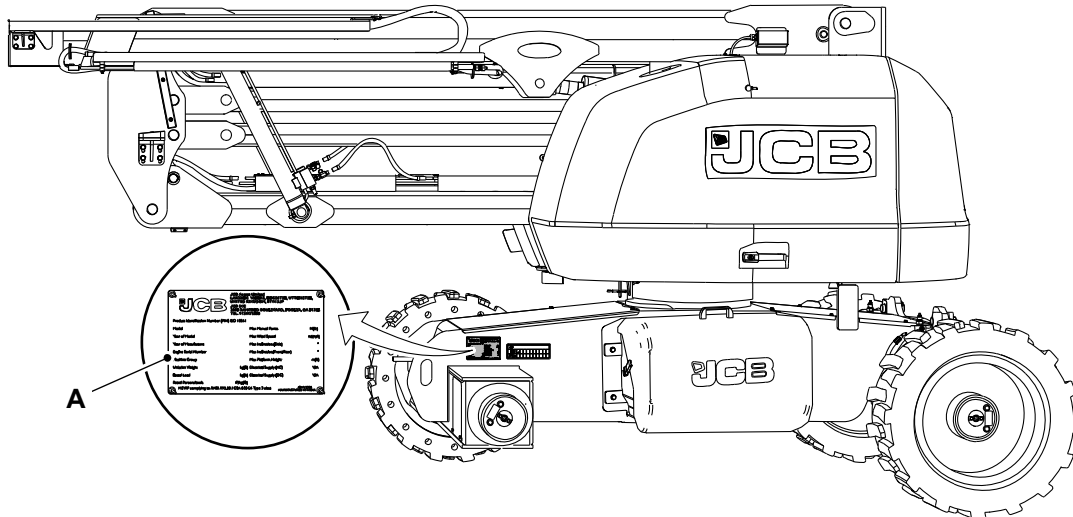

A Machine identification plate

Explanation of Machine Identification Plate

Figure 5.

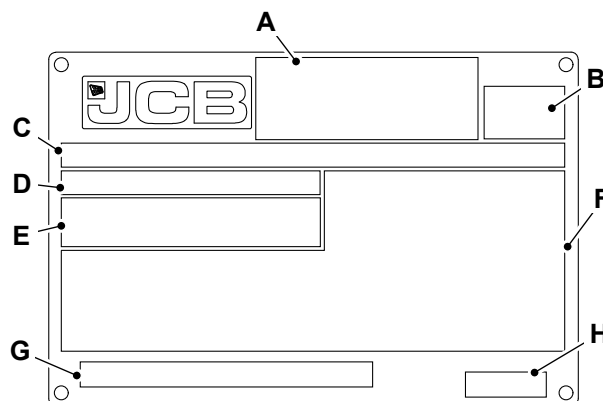

Table 2.

A	Manufacturers address
B	Regional certification mark (if applicable)
C	PIN (Product Identification Number) ISO10261
D	Model
E	Model and manufacture year (if applicable)
F	Model data
G	Product description and relevant design standards
H	Part number

Engine

The engine data labels are attached to the cylinder block and cylinder head cover as shown. Refer to Figure 6.

The data label includes the engine identification number.

Figure 6.

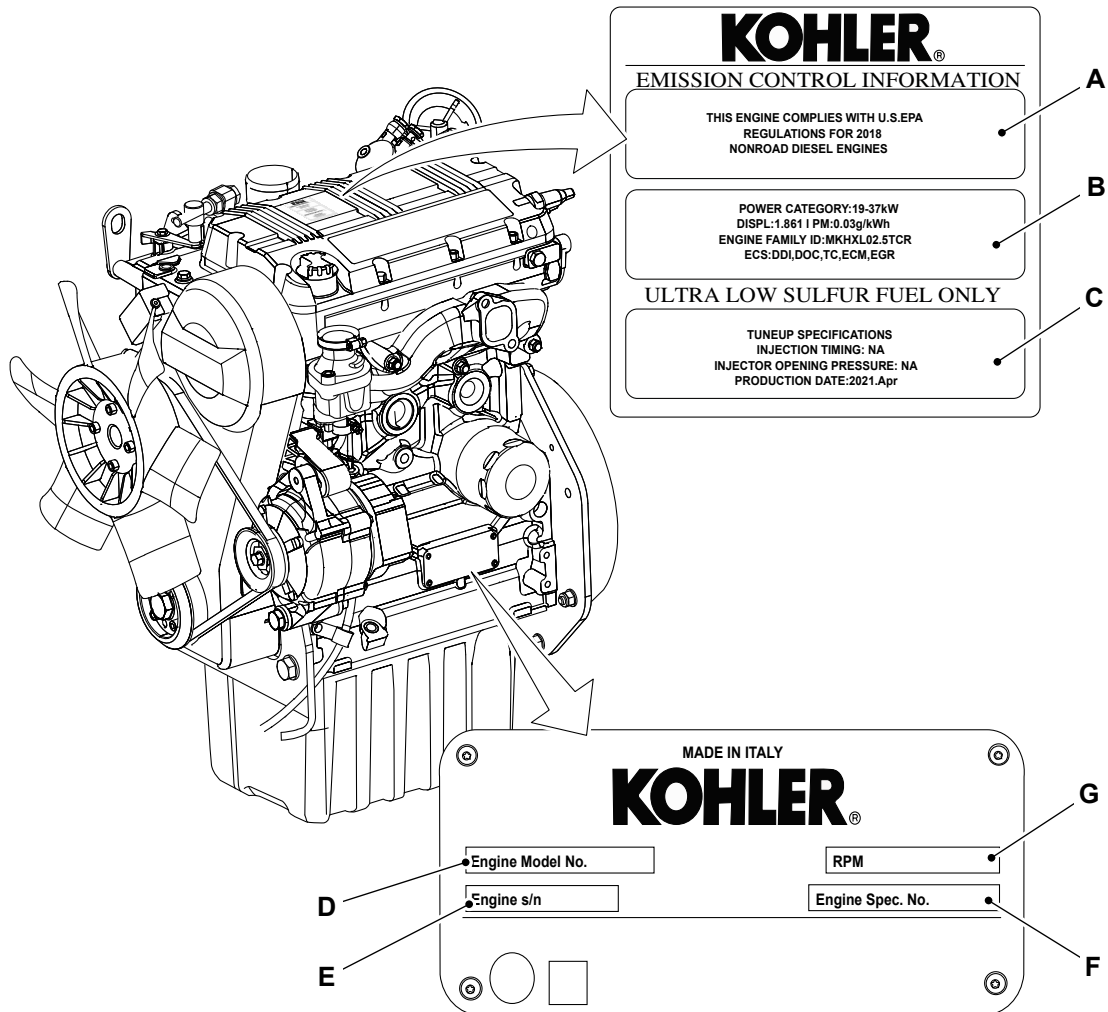

- A Regional compliance
- C Fuel specification
- E Engine serial number
- G Engine specification number

- B Engine specifications
- D Engine model number
- F Engine Rpm

Safety Labels

General

▲ WARNING Safety labels on the machine warn you of particular hazards. You can be injured if you do not obey the safety instructions shown.

The safety labels are strategically placed around the machine to remind you of possible hazards.

If you need eye-glasses for reading, make sure you wear them when reading the safety labels. Do not overstretch or put yourself in dangerous positions to read the safety labels. If you do not understand the hazard shown on the safety label, then refer to Safety Label Identification.

Keep all of the safety labels clean and readable. Replace a lost or damaged safety label. Make sure the replacement parts include the safety labels where necessary. Each safety label has a part number printed on it, use this number to order a new safety label from your JCB dealer.

Safety Label Identification

Figure 7.

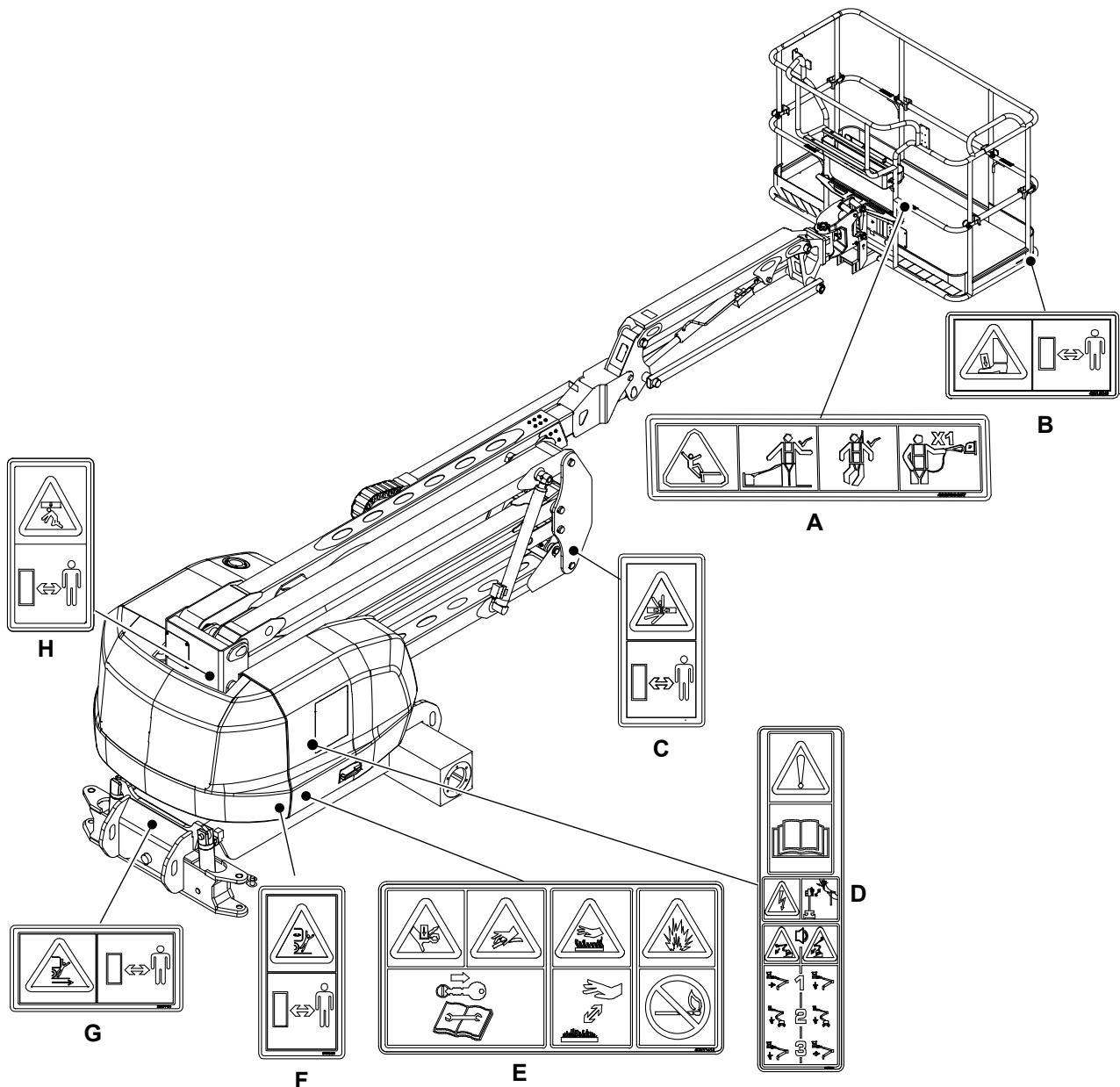

Figure 8.

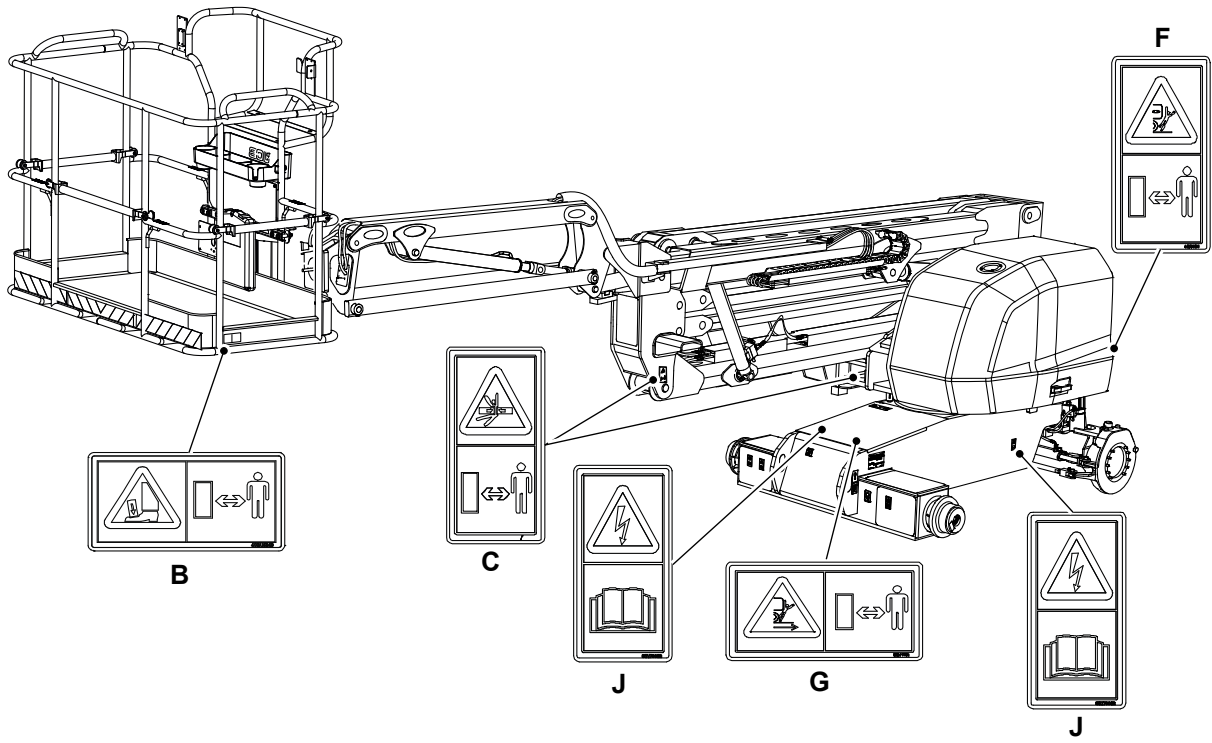

Figure 9.

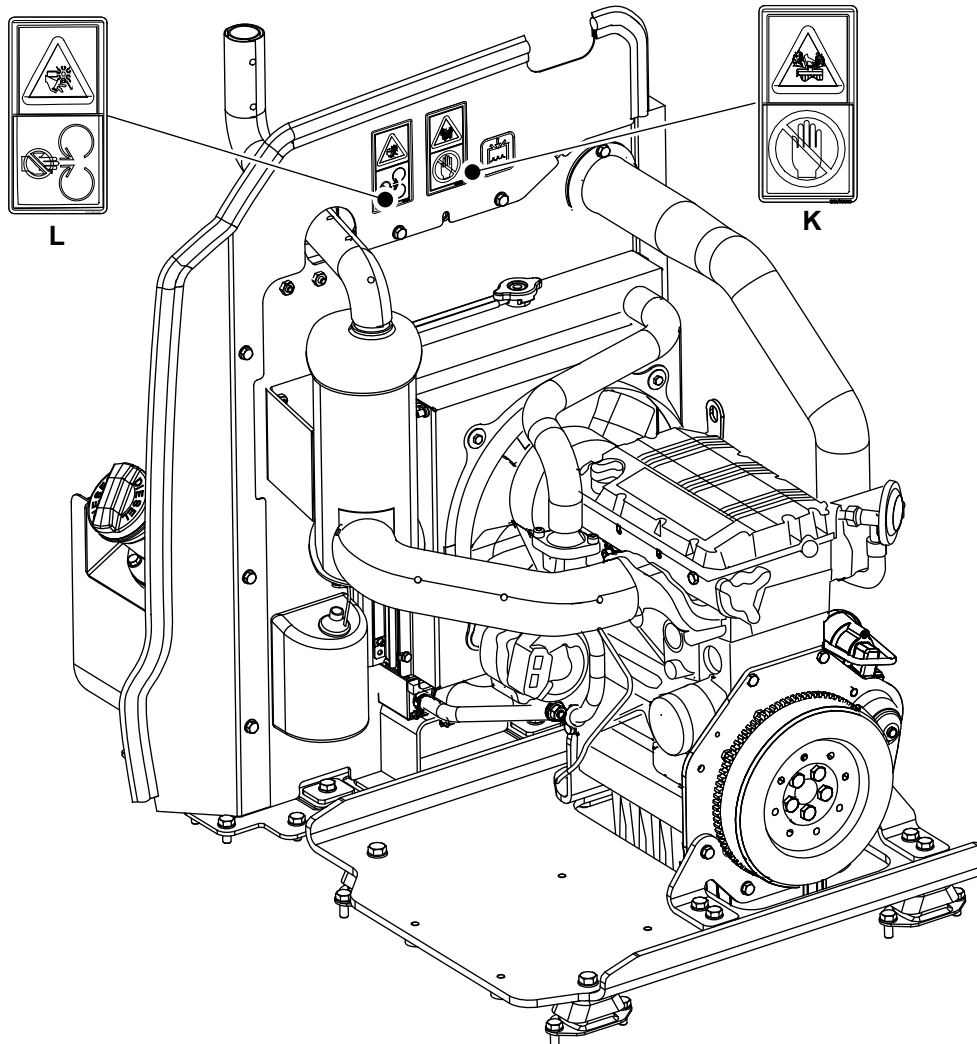

Table 3. Safety Labels

Item	Part No.	Description	Qty.
A	400/D1430	Wear safety harness.	2
B	400/U5049	(Combination label) Warning - Crush hazard (to feet). Keep a safe distance. The attachment may roll forward when released. The object may fall over from the platform.	2
C	817/70112	Warning. Crushing of whole body. Keep a safe distance.	3
D	400/V1939	(Combination label) Warning - Read the Operator's Manual before you operate the machine. Warning - Electrical hazard. Stay a safe distance away from power lines. Warning - Operate the decent alarm when you lower the boom. Follow the correct sequence while lowering the boom.	1
E	400/V1418	(Combination label) Warning - Pressure hazard. Stop the machine, remove the ignition key and consult service manual before carrying out any servicing and maintenance work. Caution - Burns to fingers and hands. Stay a safe distance away. Warning - Explosion hazard. Remove sources of ignition.	1
F	817/70106	Warning. Strike to whole body (machine swing). Keep a safe distance from the machine.	2
G	332/P7124	Strike. Keep clear of the reversing machine.	2
H	817/70110	Warning. Crushing of whole body. Keep a safe distance from machine.	1
J	817/70032	Electrical hazard. Read the Operator's Manual.	8



Item	Part No.	Description	Qty.
K	817/70005	Warning. Hot fluid under pressure. Do not touch, consult operator's manual.	1
L	332/P4581	Warning. Severing of hands and fingers. Keep clear off /do not reach into rotating parts.	1

Operation Introduction

General

The aim of this part of the manual is to guide the operator step-by-step through the task of learning how to operate the machine efficiently and safely. Read the "Operation" section thoroughly from beginning to end.

The operator must always be aware of events happening in or around the machine. Safety must always be the most important factor when you operate the machine. Driver aids must not be relied on.

When you understand the operating controls, gauges and switches, practice using them. Drive the machine in an open space, clear of people. Get to know the 'feel' of the machine and its driving controls.

Do not rush the job of learning, make sure you fully understand everything in the "Operation" section. Take your time and work efficiently and safely.

Remember:

- Be careful.
- Be alert.
- Be safe.

Operating Safety

General

Training

Make sure that you have had adequate training and that you are confident in your ability to operate the machine safely before you use it. Practice using the machine and its attachments until you are completely familiar with the controls and what they do. Where applicable you may be required to show competency to a national certification scheme. Ensure you comply with local legislation and jobsite rules. With a careful, well trained and experienced operator, your machine is a safe and efficient machine. With an inexperienced or careless operator, it can be dangerous. Do not put your life, or the lives of others, at risk by using the machine irresponsibly. Before you start to work, tell your colleagues what you will be doing and where you will be working. On a busy site, use a signalman.

Before doing any job not covered in this manual, find out the correct procedure. Your local JCB distributor will be glad to advise you.

Fuel

Fuel is flammable, keep naked flames away from the fuel system. Stop the engine immediately if a fuel leak is suspected. Do not smoke while refuelling or working on the fuel system. Do not refuel with the engine running. Completely wipe off any spilt fuel which could cause a fire. There could be a fire and injury if you do not follow these precautions.

Machine Condition

A defective machine can injure you or others. Do not operate a machine which is defective or has missing parts. Make sure the maintenance procedures in this manual are completed before using the machine.

Machine Limits

Operating the machine beyond its design limits can damage the machine, it can also be dangerous. Do not operate the machine outside its limits. Do not try to upgrade the machine performance with unapproved modifications or additional equipment.

Engine/Steering Failure

If the engine or steering fails, stop the machine as quickly as possible. Do not operate the machine until the fault has been corrected.

Exhaust Gases

Machine exhaust gases can harm and possibly kill you or bystanders if they are inhaled. Do not operate the machine in enclosed spaces without making sure there is good ventilation. If possible, install an exhaust extractor. If you begin to feel drowsy, stop the machine at once and get into fresh air.

Do not touch the exhaust or the water/steam coming out of the exhaust. Doing so may cause high-temperature burns. Never drink the water coming out of the exhaust.

Worksites

Worksites can be hazardous. Examine the site before working on it. You could be killed or injured if the ground gives way under your machine or if piled material collapses onto it. Check for potholes and hidden debris, logs, ironwork etc. Any of these could cause you to lose control of your machine. Check for utilities such as electric cables (overhead and underground), gas and water pipes etc. Mark the positions of the underground cables and pipes. Make sure that you have enough clearance beneath overhead cables and structures.

If the machine is used in coordination with other machines, vehicles and/or people on the jobsite the operator must follow jobsite organisation rules.

Communications

Bad communications can cause accidents. Keep people around you informed of what you will be doing. If you will be working with other people, make sure any hand signals that may be used are understood by everybody. Worksites can be noisy, do not rely on spoken commands.

You must stop the machine operation, isolate the controls and turn off the machine when persons are required to interact with it.

Parking

An incorrectly parked machine can move without an operator. Follow the instructions in the Operator's Manual to park the machine correctly.

Banks and Trenches

Banked material and trenches can collapse. Do not work or drive too close to banks and trenches where there is danger of collapse.

Safety Barriers

Unguarded machines in public places can be dangerous. In public places, or where your visibility is reduced, place barriers around the work area to keep people away.

Sparks

Explosions and fire can be caused by sparks from the exhaust or the electrical system. Do not use the machine in closed areas where there is flammable material, vapour or dust.

Regulations

Obey all laws, worksite and local regulations which affect you and your machine.

Electrical Power Cables

You could be electrocuted or badly burned if you get the machine or its attachments too close to electrical power cables.

You are strongly advised to make sure that the safety arrangements on site comply with the local laws and regulations concerning work near electric power lines.

Before you start using the machine, check with your electricity supplier if there are any buried power cables on the site.

There is a minimum clearance required for working beneath overhead power cables. You must obtain details from your local electricity supplier.

Machine Safety

Stop work at once if a fault develops. Abnormal sounds and smells can be signs of trouble. Examine and repair before resuming work.

Hot Components

Touching hot surfaces can burn skin. The engine and machine components will be hot after the unit has been running. Allow the engine and components to cool before servicing the unit.

Travelling at High Speeds

Travelling at high speeds can cause accidents. Always travel at a safe speed to suit working conditions.

Hillsides

Operating the machine on hillsides can be dangerous if the correct precautions are not taken. Ground conditions can be changed by rain, snow, ice etc. Check the site carefully. When applicable, keep all attachments low to the ground.

Confined Areas

Pay extra attention to proximity hazards when operating in confined areas. Proximity hazards include buildings, traffic and bystanders.

Safe Working Loads

Overloading the machine can damage it and make it unstable. Study the specifications in the Operator's Manual before using the machine.

Worksite Safety

"Workplace Inspection" will help operators to determine whether the workplace is suitable for operation. Operators must inspect the workplace before they move machines there. It is the operator's responsibility to understand and keep in mind the hazards in the workplace, He/she must pay attention and avoid these problems when moving, installing and operating the machine. Check for hazards such as but not limited to:

- Drop-offs, or potholes including those concealed by water mud, etc.
- Slopes.
- Bumps and floor obstructions.
- Debris.

- Over head obstructions and electrical conductors.
- Hazardous locations and atmospheres.
- Inadequate surface and support to withstand all load forces imposed by the platform in all operating configurations.
- Wind and weather conditions.
- Presence of unauthorized persons.
- Other possible unsafe conditions.
- Underground utilities and pipes.
- Overhanging objects, tree branches.

Risk Assessment

It is the responsibility of the competent people that plan the work and operate the machine to make a judgement about the safe use of the machine, they must take into account the specific application and conditions of use at the time.

It is essential that a risk assessment of the work to be done is completed and that the operator obeys any safety precautions that the assessment identifies.

If you are unsure of the suitability of the machine for a specific task, contact your JCB dealer who will be pleased to advise you.

The following considerations are intended as suggestions of some of the factors to be taken into account when a risk assessment is made. Other factors may need to be considered.

A good risk assessment depends on the training and experience of the operator. Do not put your life or the lives of others at risk.

Personnel

- Are all persons who will take part in the operation sufficiently trained, experienced and competent? Are they fit and sufficiently rested? A sick or tired operator is a dangerous operator.
- Is supervision needed? Is the supervisor sufficiently trained and experienced?
- As well as the machine operator, are any assistants or lookouts needed?

The Machine

- Is it in good working order?
- Have any reported defects been corrected?
- Have the daily checks been carried out?
- Are the tyres in good condition?

Working Area

- Is it level?
- Is the ground solid? Will it support the weight of the machine when loaded?
- How rough is the ground? Are there any sharp projections which could cause damage, particularly to the tyres?
- Are there any obstacles or hazards in the area, for example, debris, excavations, manhole covers, power lines?
- Is the space sufficient for safe manoeuvring?
- Are any other machines or persons likely to be in or to enter the area while operations are in progress?

The Route to be Travelled

- How solid is the ground, will it provide sufficient traction and braking? Soft ground will affect the stability of the machine and this must be taken into account.
- How steep are any slopes, up/down/across? A cross slope is particularly hazardous, is it possible to detour to avoid them?

Weather

- How windy is it? High wind will adversely affect the stability of a loaded machine.
[Refer to: Performance Dimensions \(Page 151\).](#)

- Is it raining or is rain likely? The ground that was solid and smooth when dry will become uneven and slippery when wet, and it will not give the same conditions for traction, steering or braking.

Emergency Plan

Make sure that an emergency rescue plan is in place and understood by those involved when operating the machine from the platform controller at height. It is important to make sure that those involved in the rescue plan are aware of the location of the lowering controls and how to operate the machine.

Walk-Around Inspection

General

▲ DANGER Check the brackets in the centre of the wheel hubs to ensure they are in their normal extruded position before leaving or operating the machine. Otherwise there is a risk that the machine will roll away.

The machine walk-around or pre-operation inspection is an important routine task and must be performed by the operator. This is a visual inspection that must be performed by the operator before using the machine. If there are any issues observed during inspection, then machine maintenance is required.

[Refer to: General \(Page 32\).](#)

[Refer to: Maintenance Schedules \(Page 85\).](#)

The machine walk-around or pre-operation inspection is an important routine task and must be performed by the operator. This is a visual inspection that must be performed by the operator before using the machine. If there are any issues observed during inspection, then machine maintenance is required.

[Refer to: Maintenance Schedules \(Page 85\).](#)

The following checks must be made each time you return to the machine after leaving it for any period of time. We advise you also to stop the machine occasionally during long work sessions and do the checks again.

All these checks concern the serviceability of the machine. Some concern your safety. Get your service engineer to check and correct any defects.

1. Check for cleanliness.
 - 1.1. Remove dirt and debris, especially from around the linkages, rams and pivot points.
 - 1.2. Make sure that the platform floor and handrails are clean and dry.
 - 1.3. Clean all of the safety and instructional labels. Replace any label that is missing or cannot be read.
2. Check for damage.
 - 2.1. Examine the machine generally for damaged and missing parts.
 - 2.2. Make sure that all of the fasteners and pivot pins are correctly installed.
 - 2.3. Check the operation of the platform side rails.
 - 2.4. Check the condition of the tyres.
 - 2.5. Check for leaks.
3. Make sure that all of the access panels are closed correctly.
 - 3.1. If access panels are installed with locks, we recommend that you lock them to prevent theft or tampering.
4. Check condition of safety harness anchorage points. Check the condition after any excessive loading.
5. Check the brackets in the centre of the wheel hubs to ensure they are in their normal extruded position before leaving or operating the machine. Otherwise there is a risk that the machine will roll away.
[Refer to: General \(Page 51\).](#)
6. Check the operation of all controls.
7. Check the operator's manual is in good condition and is kept in the operator's manual storage compartment.
[Refer to: Location of Manual \(Page 2\).](#)
8. Check the level of the hydraulic fluid and for leaks.
9. Check the condition of the batteries, cables and wiring.
10. Check the operation of the safety equipment.
[Refer to: Check \(Operation\) \(Page 106\).](#)



11. Before operating the boom and drive functions remove the slew lock by positioning the slew lock pin in the unlock position.

Entering and Leaving the Platform

General

- ▲ **CAUTION** Entering or leaving the operator station must only be made where handrails are provided. Always face the machine when entering and leaving. Make sure the handrails and your boot soles are clean and dry. Do not jump from the machine. Do not use the machine controls as handholds, use the handrails.

Make sure the machine is stopped, correctly parked and fully stowed before entering or leaving the platform. [Refer to: Stopping and Parking \(Page 27\)](#).

When entering and leaving the platform always maintain three points of contact. Three points of contact means that two hands and one foot or one hand and two feet are in contact with platform or ground at all times. Do not use the machine controls as handholds.

Before entering and leaving the platform, make sure that the platform is fully lowered.

Entering the Platform

1. Move and hold the slider tube in upward direction. [Refer to Figure 10](#).
2. Step into the platform.
3. Move the slider tube to its original position.

Leaving the Platform

1. Park the machine on solid, firm, level ground.
2. Move and hold the slider tube in upward direction. [Refer to Figure 10](#).
3. Step out from the platform.
4. Move the slider tube to its original position. [Refer to Figure 10](#).

Figure 10.

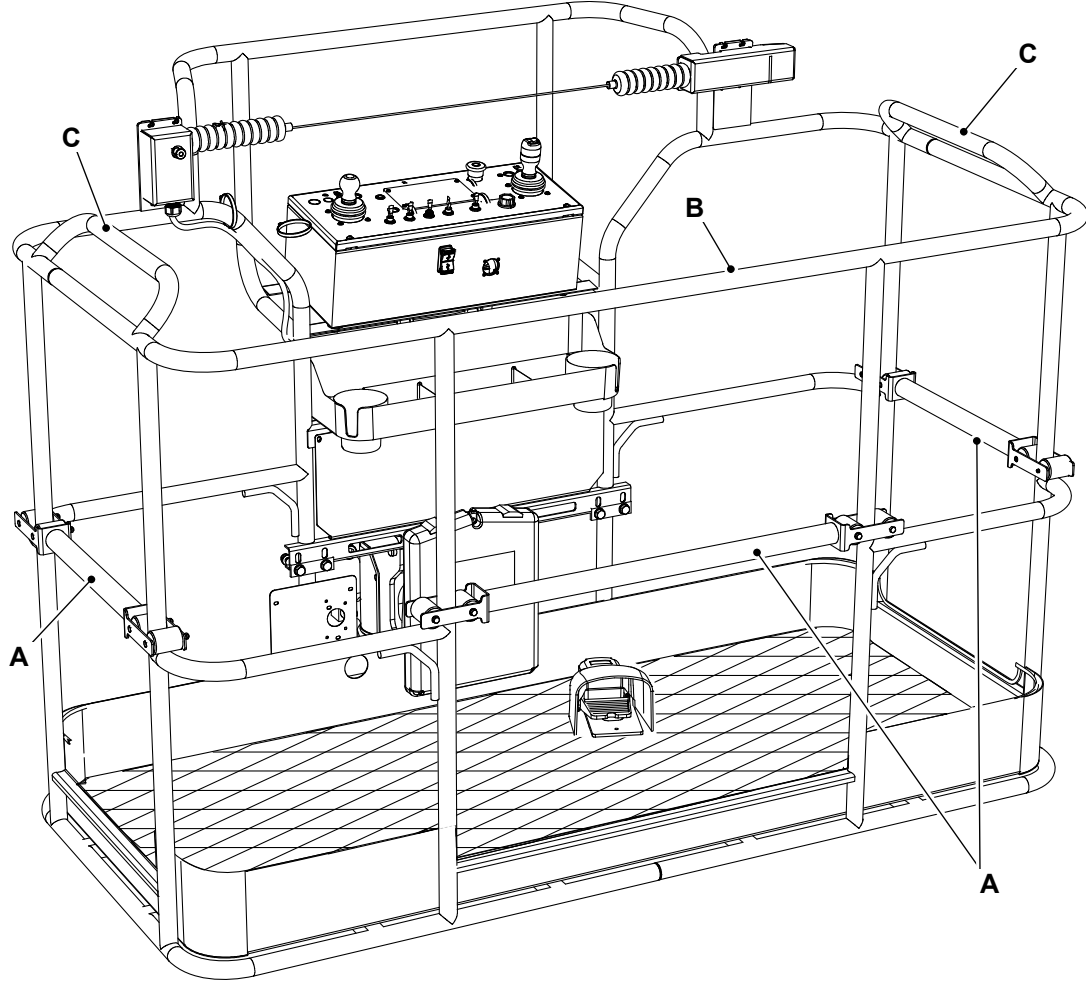

A Sliding tubes
C Handrail

B Guardrails

Service Disconnect

General

▲ **WARNING** The batteries remain live even when the isolator key is removed.

Disconnect the Machine Electrics:

1. Turn the key switch to the OFF position.
2. Get access to the battery isolator.
3. Disconnect the battery isolator.

Figure 11.

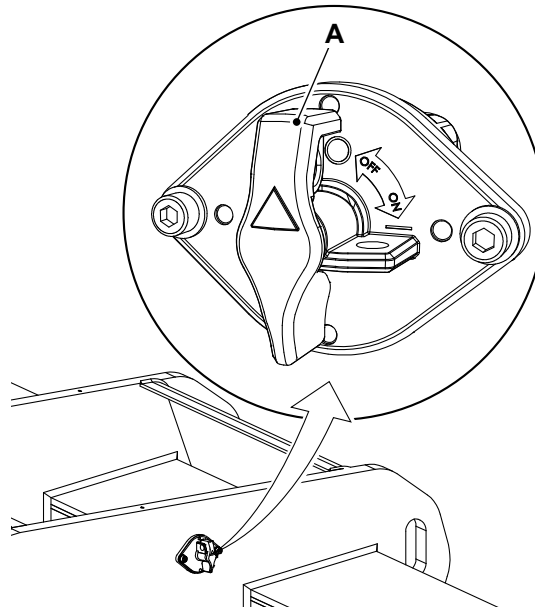

A Isolator switch

Connect the Machine Electrics:

1. Make sure the key switch is at OFF position.
2. Connect the battery isolator.

Ignition Key

1. Key is removable only in OFF position.
2. When ignition key and isolator both are at ON position, high voltage DC (Direct Current) power is connected.
3. When ignition key is at 'ON' and isolator is at 'OFF' position, high voltage DC power is disconnected.
4. If the ignition key is at 'OFF' position but the isolator is at 'ON' position, then DC power is connected to busbars.

Figure 12.

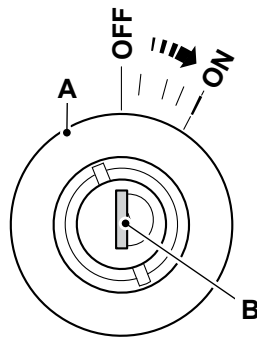

A Ignition lock

B Ignition key

Figure 13.

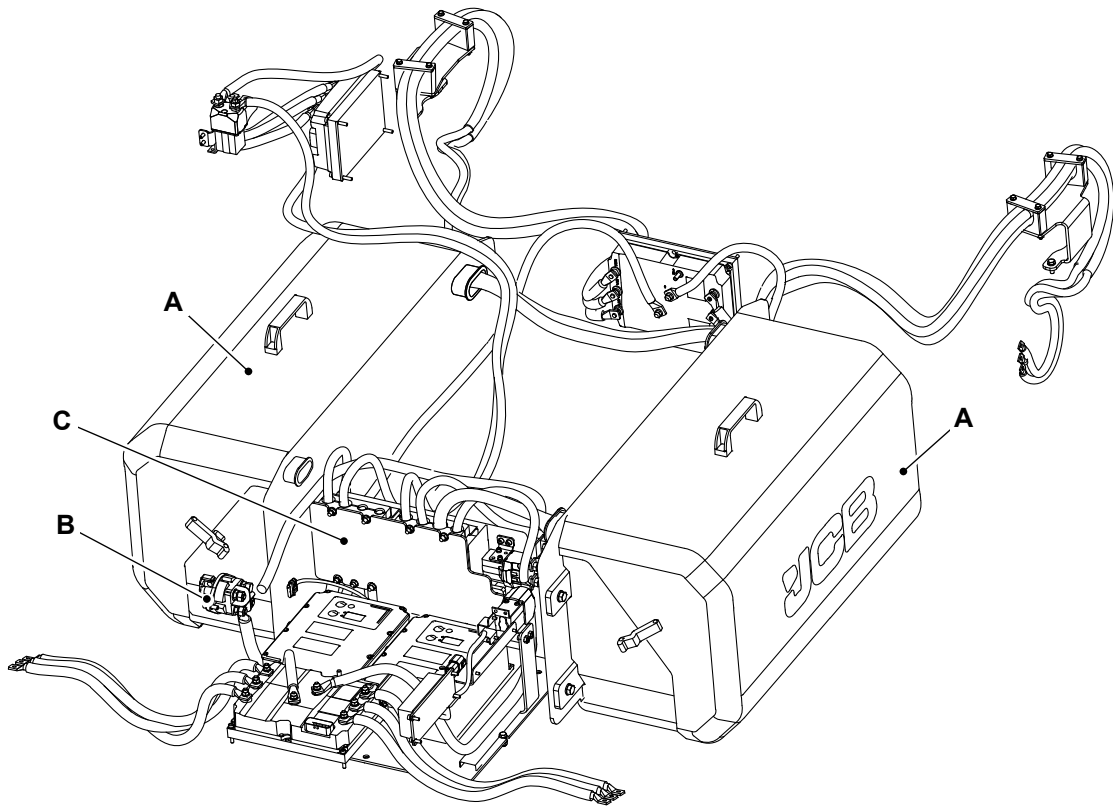

A Battery compartment (DC power source)
C Busbar

B Battery isolator

Starting the Machine

General

When there is any error / safety fault code condition the machine is stopped by the electrical safety system. To continue using the machine rectify the cause of the error / safety fault code and then perform an OFF / ON cycle of the key switch or press the emergency stop in and pull it back out. If the issue continues contact your JCB dealer.

When the machine is initially operated in ambient temperatures ranging below -10°C (14.0°F), the electric motor speed is automatically reduced, leading to slower service speeds. Once the machine has warmed up sufficiently during operation, the electric motor speed will revert to standard, restoring service speeds.

1. Make the machine safe.
[Refer to: Maintenance Positions \(Page 91\).](#)
2. Make sure that both the emergency stop switches at the base and platform control panel are released.
3. Make sure that the canopies, bus bar cover, change over box and battery pods are securely covered and locked.
4. Turn ON the isolator switch and then turn the ignition key switch to the ON position.
[Refer to: Service Disconnect \(Page 24\).](#)
5. Auto engine start feature is enabled in the machine at every key cycle.
 - 5.1. The engine will start automatically when the battery charge level drops below 50% and either the foot pedal input or the base control enable switch is pressed.
 - 5.2. The base ECU (Electronic Control Unit) will turn OFF engine when battery charger current $<20\text{A}$ received from master charger on CAN2 for 20s.
6. The engine auto start feature can be disabled either from the display menu or by pressing the auto engine start push button on the platform control panel.
7. Press the engine ON / OFF switch at the base and platform control panel and engine will start after 8-10 seconds.
 - 7.1. The pre-heat timer for the glow plug will turn on the glow plug based on the ambient temperature.
 - 7.2. The auto start icon blinks on the display and the buzzer beeps, indicating that the engine will start.
[Refer to: Instrument Panel \(Page 28\).](#)
8. All machine operations can be performed from the base and platform control panel.

Note: The machine does not have high torque and low torque modes.

Stopping and Parking

General

The machine uses an electronic park brake in all four wheel motors.

The park brakes release automatically during travel and steer. The park brakes do not release during lifting.

1. Select a safe place to stop where the ground is firm and level such as slabbed or paved surface, where the machine will not cause an obstruction and away from heavy traffic.
2. Lower the platform to stowed position.
3. Rotate the turntable to secure the boom between the non steer wheels.
4. Turn the key switch to the off position. Remove the key to avoid unauthorized use.

Brake Operational Limits

The machine is capable of stopping from its maximum speed on the maximum gradients as stated in this manual.

It is recommended that the machine is not parked or left unattended on slopes greater than those specified in this manual. It is the responsibility of the operator to assess the ground and atmospheric conditions before using or parking the machine on gradients.

The machine must be immediately taken out of service until corrected if the park brakes do not operate within specifications or performance requirements as defined in this manual or any other in-service, periodic or post maintenance brake verification.

Instruments

Instrument Panel

- ▲ **CAUTION** Keep the machine controls clean and dry. Your hands and feet could slide off slippery controls. If that happens you could lose control of the machine.

There are two control panels, one is located on the right side of the machine base, the other is in the operator platform.

Base Control Panel

- ▲ **WARNING** Do not operate the machine with the base control when there are personnel in the platform except in an emergency.

Figure 14.

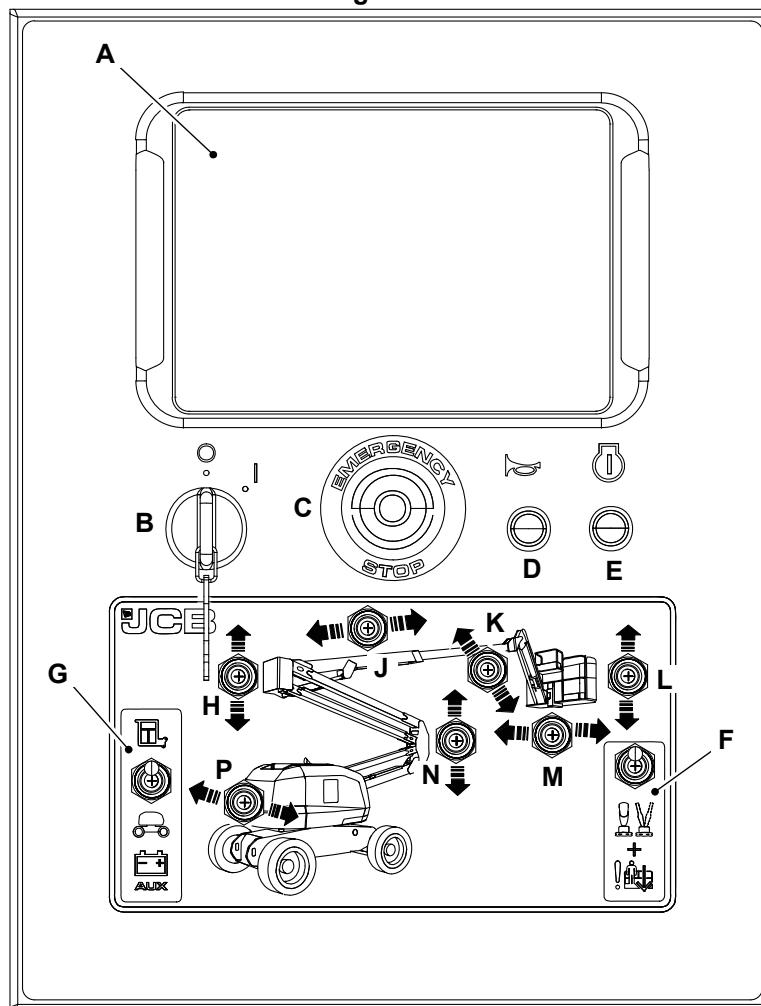

- | | |
|--|---|
| A Display | B Key switch |
| C Emergency stop button | D Horn button |
| E Engine start / stop button | F Emergency override switch |
| G Base control enable switch | H Main boom raise / lower switch |
| J Telescopic boom extend / retract switch | K Jib raise / lower switch |
| L Platform level switch | M Platform rotate switch |
| N Articulated boom raise / lower switch | P Slew left / right switch |

Base Control Display

Figure 15.

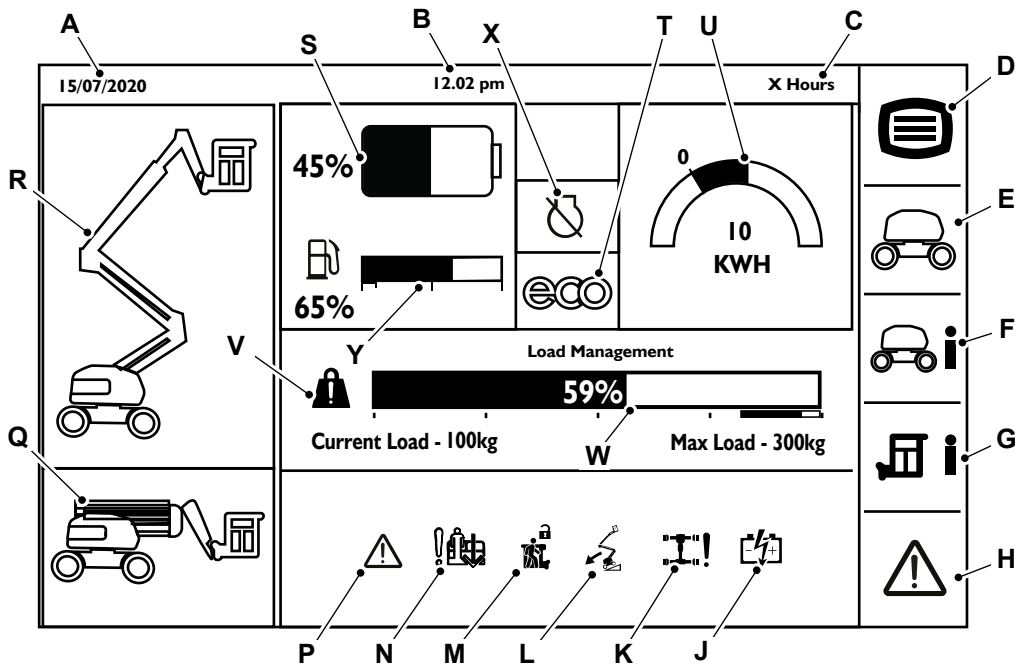

Table 4.

Callout	Indicator	Description
A	Date	Displays current date.
B	Time	Displays current time.
C	Machine hour	Displays machine running hours.
D	Display settings	Displays settings for the display.
E	Machine settings	Displays locked screen for new settings of machine.
F	Base information	Displays base information of machine like input, output and machine information.
G	Platform information	Displays platform input / output information.
H	Faults	Displays live and historic faults.
J	Battery voltage warning	Displays when battery voltage is high / low.
K	Power train fault lamp	Displays when there is a fault on the power train.
L	Tilt limit exceeded	Displays when machine tilt limit is exceeded. Solid lamp if the machine is stowed. Flashing lamp if the machine is raised.
M	Secondary guarding	Displays when the platform secondary guarding is in active condition.
N	Emergency override	Displays when emergency override has been activated.
P	Fault indicator	Displays when there is a fault on the machine.
Q	Machine stowed position	Displays when machine is in stowed position.
R	Machine raised position	Displays when machine is in raised position.
S	Battery charging level indicator	Displays the battery charging condition in percentage.
T	ECO mode	Displays if ECO mode is enabled. The machine must be in ECO mode when power utilisation is below 20kW and when any of the function is active.
U	Power utilisation	Displays the power utilisation.

Callout	Indicator	Description
V	Overload lamp	Displays when the platform load limit is exceeded. Solid lamp if the load is approaching the limit. Flashing lamp if the load is above the limit.
W	Load management indicator	Displays the amount of load machine is carrying in percentage.
X	Engine auto start telltale	Displays engine in auto start mode or not
Y	Fuel level indicator	Displays the level of diesel fuel in the tank. Do not let the tank run dry; air will enter the fuel system. Do not run the engine if the indicator needle goes into the red area. First segment of fuel gauge blinks to show reserve capacity.

Platform Control Panel

▲ WARNING Do not drive the machine with the platform raised except on smooth, firm and level surface free of obstructions and pot holes.

Figure 16.

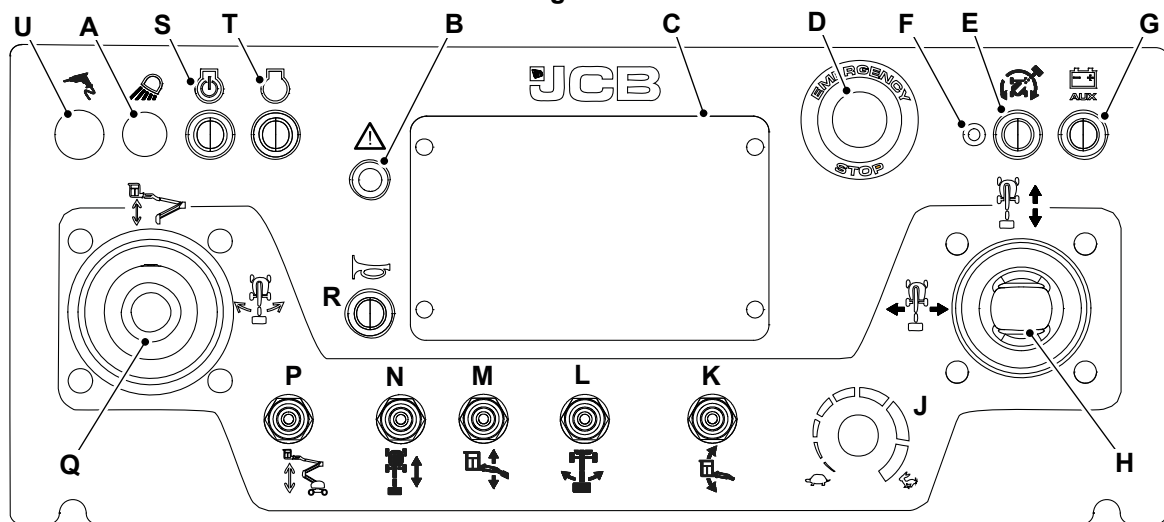

- | | |
|---|---|
| A Work lights ON / OFF button | B Error indicator |
| C Platform control panel display | D Emergency stop button |
| E Slew acknowledgement button | F Slew acknowledgement indicator |
| G Auxiliary power button | H Drive and steer joystick |
| J Speed control switch | K Manual platform level switch |
| L Platform rotate switch | M Jib boom up / down switch |
| N Telescope boom in / out switch | P Articulated boom up / down function switch |
| Q Main boom lift and slew joystick | R Horn button |
| S Engine stop / start button | T Engine auto start telltale |
| U Power to platform button | |

Platform Control Display

Figure 17.

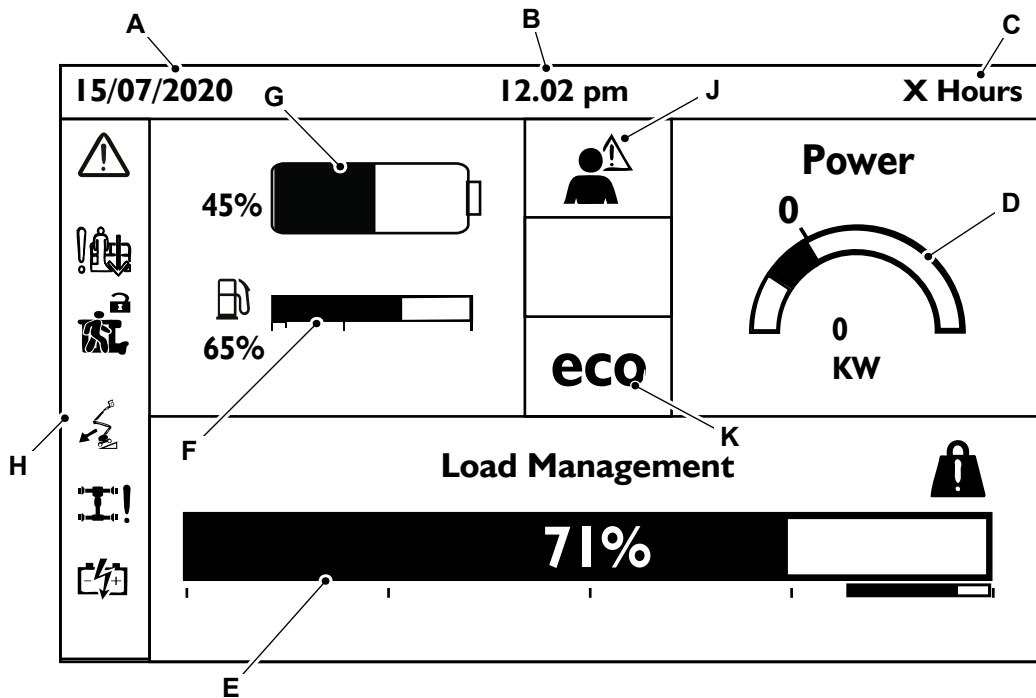

Table 5.

Callout	Indicator	Description
A	Date	Displays current date.
B	Time	Displays current time.
C	Machine hour	Displays machine running hours.
D	Power utilisation gauge	Displays the power utilisation.
E	Load management indicator	Displays the amount of load machine is carrying in percentage.
F	Battery charging level indicator	Displays the battery charging condition in percentage.
G	Fuel level indicator	Displays the level of diesel fuel in the tank. Do not let the tank run dry; air will enter the fuel system. Do not run the engine if the indicator needle goes into the red area. First segment of fuel gauge blinks to show reserve capacity.
H	Fault indicator display	Displays fault indicators.
J	Operator error or caution alarm	Appears when machine is operated outside the limits.
K	ECO mode	Displays if ECO mode is enabled.

Getting the Machine Moving

General

▲ **WARNING** Watch for obstructions around machine and overhead when driving. Check clearance above, to sides, at bottom of machine when lifting or lowering the platform.

WARNING Do not operate the machine from the platform to release the platform when it is stuck, snagged or caught. In this case, use the base control only when there are no persons on the platform.

DANGER Check the brackets in the centre of the wheel hubs to ensure they are in their normal extruded position before leaving or operating the machine. Otherwise there is a risk that the machine will roll away.

Perform the pre-operation checks before using the machine.

Refer to: [Check \(Operation\) \(Page 100\)](#).

Disengage the slew lock pin. [Refer to Figure 18](#).

Figure 18.

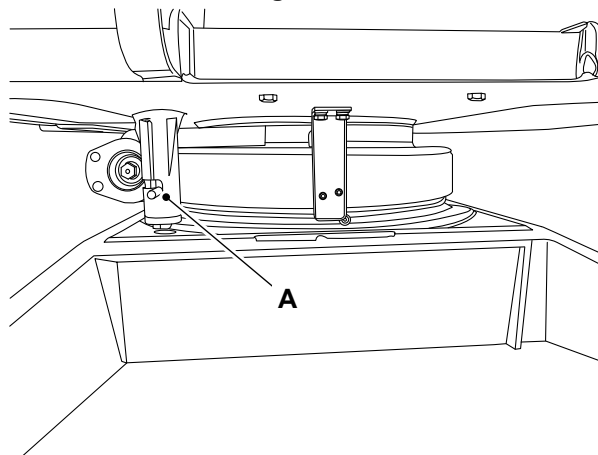

A Slew lock pin

Raising and Lowering the Platform

Operation from Base

1. Make sure that the base and platform emergency stop buttons are released and there are no faults or alarms active on the machine.
2. Turn the ignition switch to the ON position.
3. Push and release the engine start /stop button to start the engine. Do not push the base control enable switch when starting the engine.
4. Push and hold the base control enable switch, followed by the relevant function switch to raise or lower the platform in the required direction.
5. When operating the platform, a amber beacon will flash and a white noise alarm will sound at the chassis to draw the attention of nearby persons to keep a safe distance from the machine as booms and platform are operating.

Drive and steer functions are not available from the base control panel.

Operation from the Platform

1. Make sure that the base and platform emergency stop buttons are released and there are no faults or alarms active on the machine.
2. Turn the ignition switch to the ON position.

3. Push and release the engine start /stop button to start the engine. Do not push down the foot pedal when starting the engine.
4. Push and hold the foot pedal, followed by the relevant function switch or joystick / lever in the desired direction to raise or lower the platform.
5. When operating the platform, a beacon will flash and a white noise alarm will sound at the chassis to draw the attention of nearby persons to keep a safe distance from the machine as booms and platform are operating.
6. Turn the potentiometer to set desired speed.

With the travel speed potentiometer at its minimum position it is possible that some services may not function when operated from the platform control panel. Make sure to adjust the travel speed potentiometer for smooth movement.

Multi-functions

When operating the boom controls, some functions may not be permitted simultaneously. In this case, the operation commanded first will be prioritised. To indicate that an operation is not permitted, the operator caution icon will be shown on the base and platform control panel displays. To find out more information about which operations are not permitted simultaneously on your machine, contact your local JCB dealer.

Slopes

General

- ▲ **WARNING** Make sure that you have been trained and are familiar with the use of machines on slopes, and understand the adverse effects that slopes and site conditions can have on stability. Never use the machine on a slope if you do not understand the recommended practices for the use of machines in such applications.

There are a number of factors which can adversely affect the stability of the machine and the safety of the machine and operator when used on a slope.

It is essential that a risk assessment of the work to be done is completed and that the operator complies with any safety precautions that the assessment identifies.

Machine can be driven both in reverse and forward direction.

Driving on Slopes

- ▲ **WARNING** If the tilt indicator warning light/alarm is activated while driving with platform raised, lower the platform and drive to a smooth firm level surface.

WARNING Make sure that the platform is fully stowed while driving the machine on slopes and gradient, otherwise it may affect the stability of the machine.

Understand the uphill, downhill and side slope ratings for the machine and determine the grade of the slope. Do not use the machine on the slope if the rating is exceeded.

Slope rating is subject to ground conditions and adequate traction. The term gradeability applies to the machine when it is in the stowed position only.

Move the travel speed potentiometer clockwise for high wheel motor torque performance.

Make sure that while driving on slopes with the platform fully stowed, the front / back and side slope does not exceed the rated gradient for the machine.

While driving on slopes it is possible to partially raise the platform before leaving the stowed position and drive the machine, even when the chassis angle is above the rated maximum limit.

While driving on a slope, reduce the travel speed by turning the potentiometer anticlockwise to a minimum position.

Platform in Stowed Condition

Downhill Slope

Maximum slope rating, platform downhill (gradeability):

40% (22°)

Figure 19.

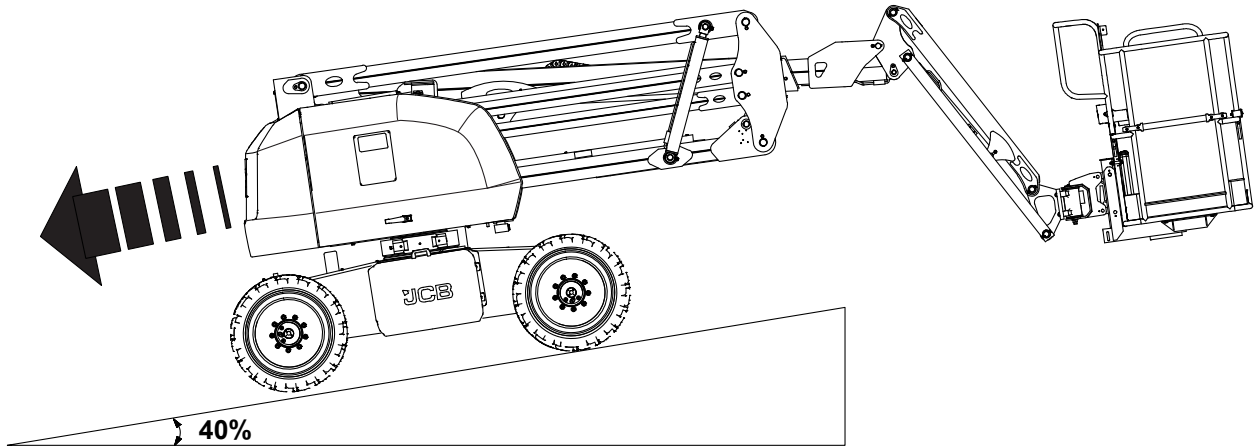

Uphill Slope

Maximum slope rating, platform uphill:

40% (22°)

Figure 20.

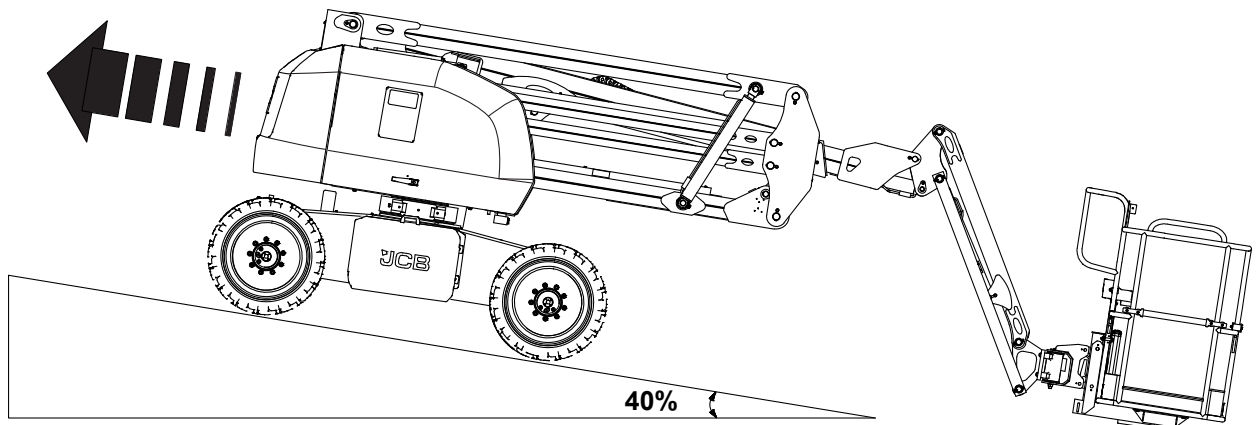

Side Slope

Maximum side slope rating:

25% (14°)

Figure 21.

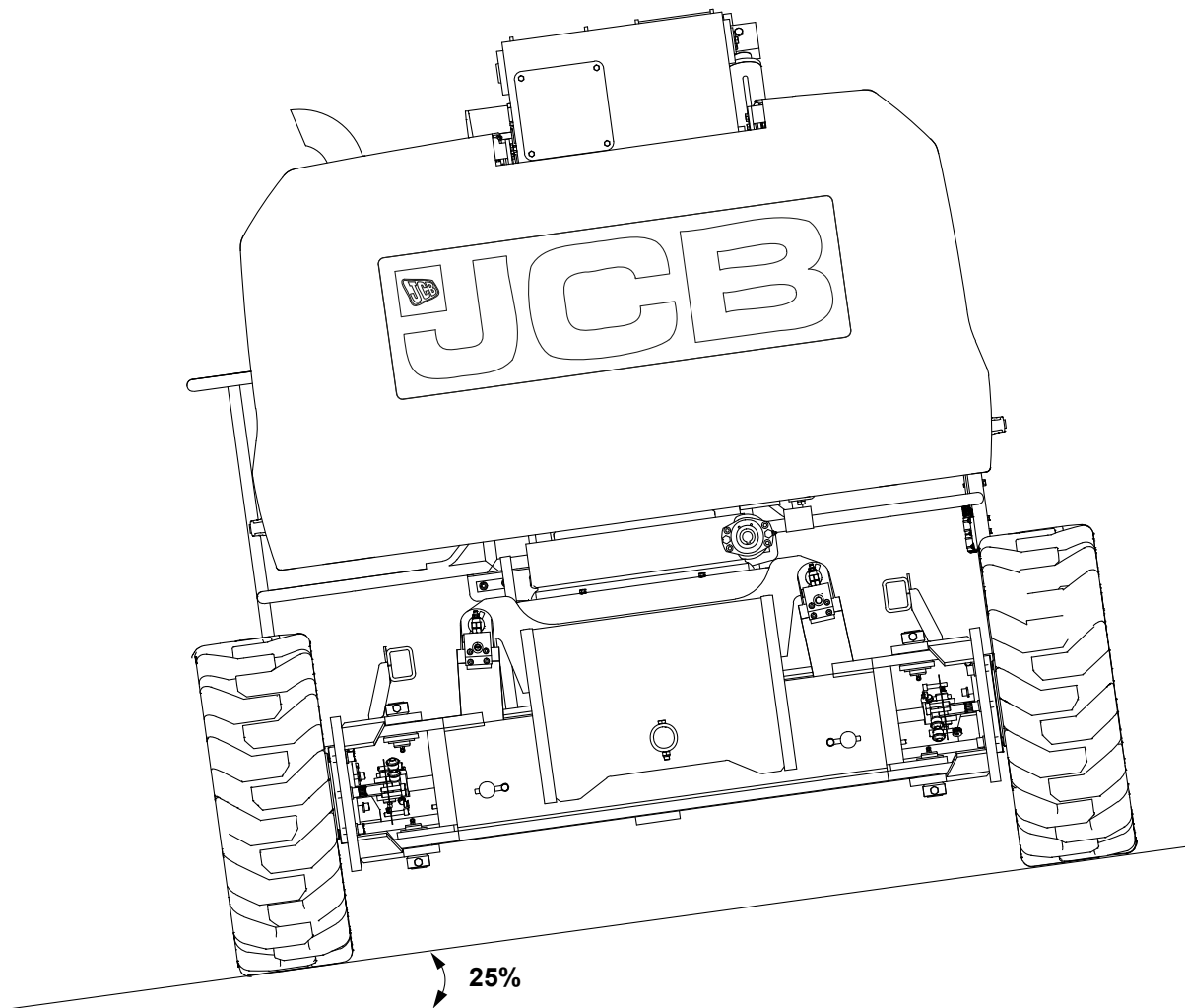

Platform in Raised/ Partial Raised Condition

Make sure that while driving on slopes with the platform raised, front/back slope and side slope does not exceed the 5° in all orientations.

Figure 22. Side Slope

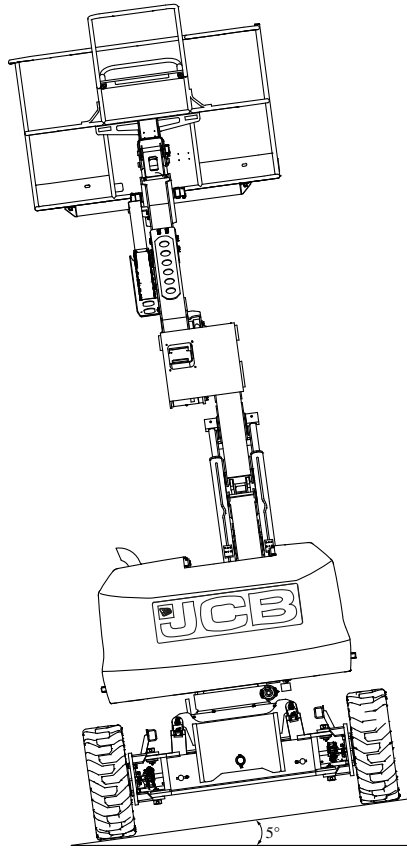
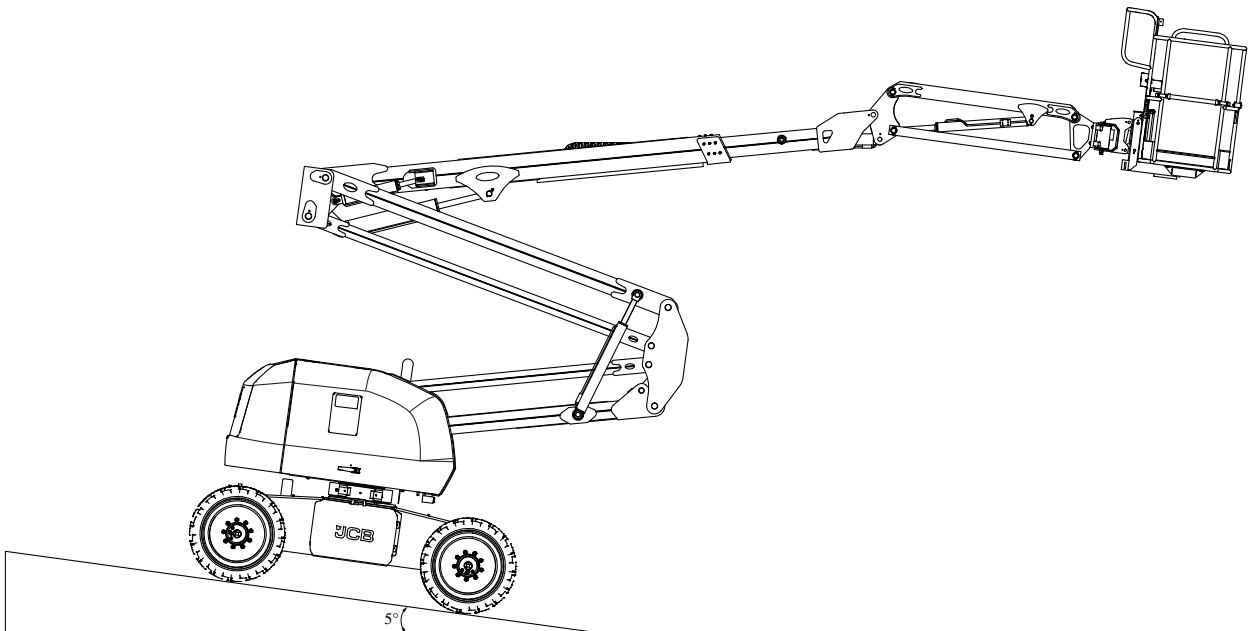

Figure 23. Front or Back Slope



Driving the Machine

General

▲ WARNING Do not operate the machine from the platform to release the platform when it is stuck, snagged or caught. In this case, use the base control only when there are no persons on the platform.

WARNING Watch for obstructions around machine and overhead when driving. Check clearance above, to sides, at bottom of machine when lifting or lowering the platform.

Altitude

The machine shall only be operated at an altitude up to 1,000m above mean sea level.

Operation from Base

1. Drive and steer functions are not available on the base control.

Operation from Platform

1. Release both base and platform emergency stop buttons.

To Steer

1. Press down the foot pedal switch.
2. Press the steering switch left or right to change the steering direction of the steering wheels according to the markings on the control panel.

Refer to: [Basic Controls \(Page 40\)](#).

Use the colour-coded direction arrows on the platform controls and the chassis to identify the direction the wheels will turn.

Figure 24.

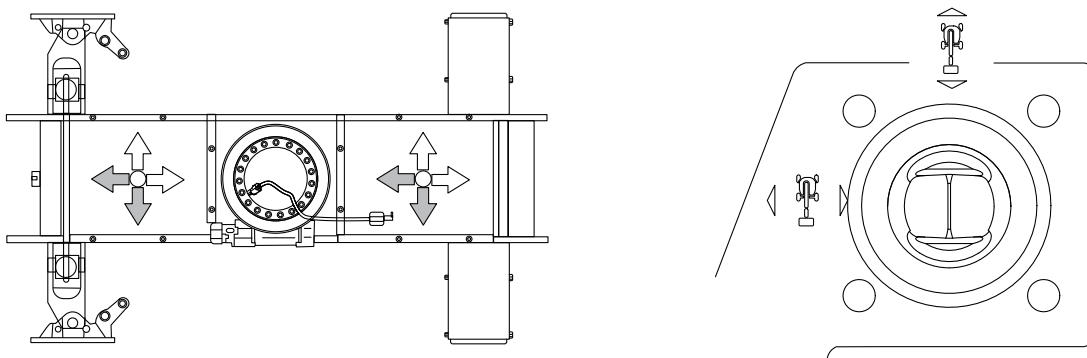

To Drive

1. Turn the potentiometer clockwise or anticlockwise to select travel speed.
2. While driving on a slope, reduce the travel speed by turning the potentiometer anticlockwise to a minimum position.
3. Press down the foot pedal to enable the platform control.
4. Move the travel joystick to forward or reverse direction to move.
5. Release the joystick to stop the machine.

Use the colour-coded direction arrows on the platform controls and the chassis to identify the direction the wheels will turn.

If the foot pedal is pushed for more than 10 seconds with no operation, it will time-out. The foot pedal should be released and pushed again to enable movements again.

Machine travel speed is reduced when the main boom or articulated boom is raised above their respective lower limit switches, or when the telescopic boom is extended beyond its retract limit switch. If maximum drive speed is necessary, it is recommended to fully stow the main boom and articulated boom. Refer to the main boom, articulated boom and telescopic boom switch position limits.

Slew Acknowledge

Figure 25.

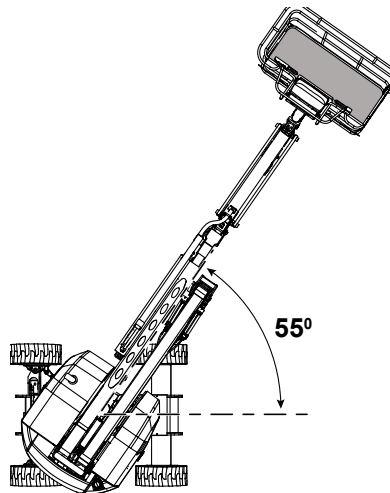

1. If the turntable is slewed more than the specified angle from the forward position (between the non-steer wheels), drive and steer functions will not be available until the operator acknowledges the slew orientation. Angle: +/- 55 degree.
2. The slew position indicator LED (Light Emitting Diode) will flash.
3. Press down the foot pedal switch.
4. Press the slew acknowledge button located below the slew position indicator LED to acknowledge the slew orientation.
5. The slew position indicator LED will change to a constant light.
6. The drive and steer functions will be enabled until the foot pedal switch is released.

Multi-functions

When operating the drive controls, some boom functions may not be permitted simultaneously. In this case, the operation commanded first will be prioritised. The indication that an operation is not permitted is the operator caution icon/LED will lit at the base and platform control panels. To find out more information about which operations are not permitted simultaneously on your machine, contact your local JCB dealer.

Operating Levers/Pedals

Basic Controls

Main Boom Lift and Slew Joystick

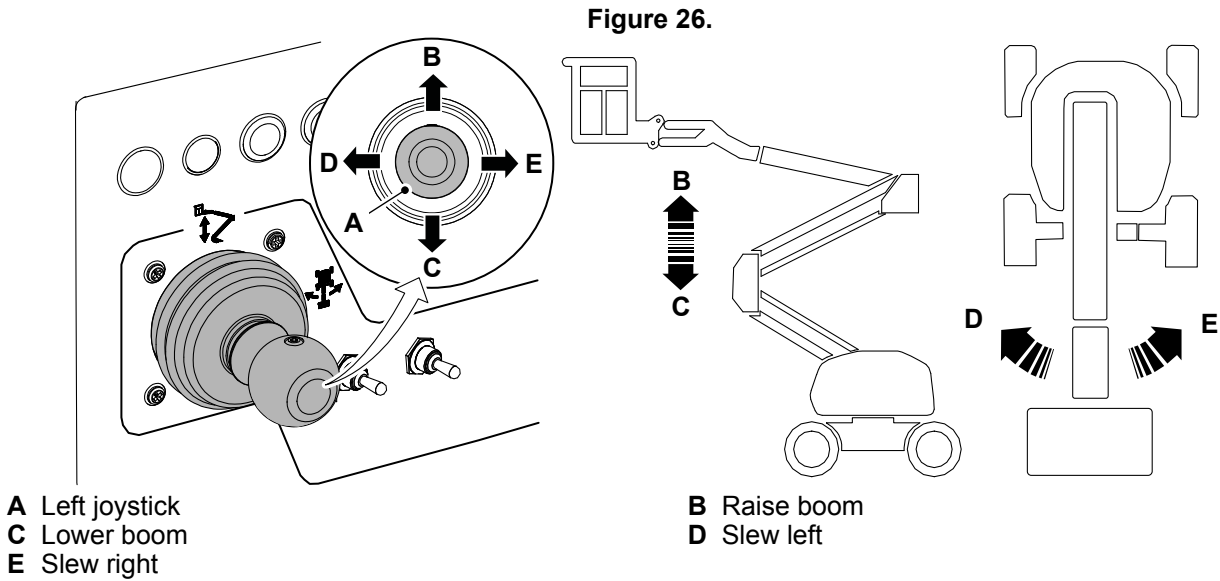

Drive and Steer Joystick

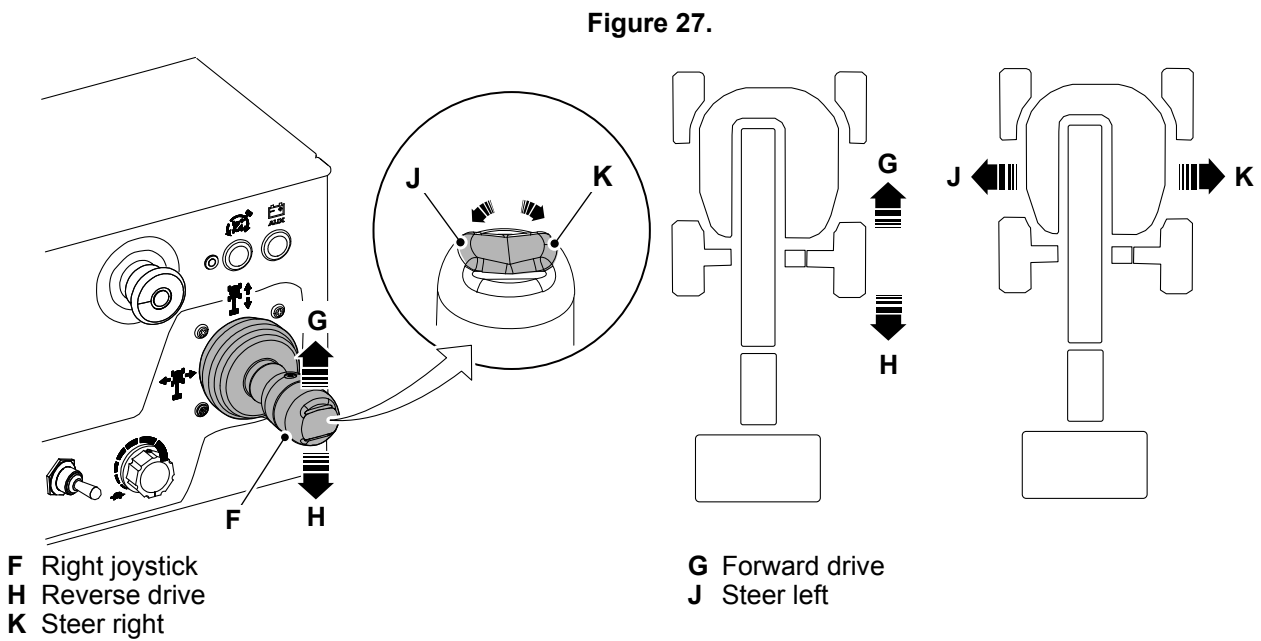

Working with the Platform

General

Trip and Fall Hazards

- Prior to operation, make sure that all operator door and guard rails are fastened and secured in their proper position.
- It is recommended that all persons in the platform wear full body harnesses with a short lanyard attached to an authorised lanyard anchor point while operating this machine. For further information refer to JCB dealer.
- Keep both feet firmly on the platform floor at all times. Never position ladders, boxes, steps, planks or other similar items on unit to provide additional reach for any purpose.
- Never use the boom assembly to enter or leave the platform.
- Use extreme caution when entering or leaving platform. Make sure that the boom is fully lowered. It may be necessary to telescope out to position the platform closer to the ground for entering or leaving. Face the machine, maintain “three point contact” with the machine, using two hands and one foot or two feet and one hand during entering and leaving.
- Keep your footwear and the platform floor clean of oil, mud and slippery substances.

Electrocution Hazards

- This machine is not insulated and does not provide protection from contact or proximity to electrical conductors.
- Maintain distance from electrical conductors, apparatus, or any energized (exposed or insulated) parts according to the Minimum Approach Distance. [Refer to Table 6.](#)
- When determining safe distance, allow for machine movement and electrical line swaying.
- The minimum approach distance may be reduced if insulating barriers are installed to prevent contact, and the barriers are rated for the voltage of the line being guarded. These barriers shall not be part of (or attached to) the machine. The minimum approach distance shall be reduced to a distance within the designed working dimensions of the insulating barrier. This determination shall be made by a qualified person in accordance with the employer, local, or governmental requirements for work practices near energized equipment.

Table 6. Minimum Approach Distance

Voltage Range	Minimum Approach Distance
0→50,000V	3m
50,000→200,000V	5m
200,000→350,000V	6m
350,000→500,000V	8m
500,000→750,000V	11m
750,000→1,000,000V	14m

Tipping Hazards

- Make sure that the ground conditions are adequate to support the maximum tyre load indicated on the tyre load decals located on the chassis adjacent to each wheel. Do not travel on unsupported surfaces.
- The user must be familiar with the driving surface before driving. Do not exceed the allowable sideslope and grade while driving.
- Do not raise the platform or drive with platform raised while on or near a sloping, uneven, or soft surface. Make sure that the machine is positioned on the level, solid (slabbed or paved) ground before elevating platform or driving with the platform in the elevated position.
- Before driving on floors, bridges, trucks, and other surfaces, check allowable capacity of the surfaces.
- Never exceed the maximum work load as specified on the platform. Keep all loads within the confines of the platform. Evenly distribute the load across the platform, or the machine could become unstable.
- Keep the chassis of the machine suitably away from holes, bumps, drop-offs, obstructions, debris, concealed holes, and other potential hazards on the floor/surface.
- Do not push or pull any object with the boom.
- Do not operate the machine when wind conditions exceed the limit.
- Never attempt to use the machine as a crane. Do not tie-off machine to any adjacent structure. Never attach wire, cable, or any similar item to platform.

- If the platform or booms becomes stuck or snagged on an adjacent or overhead structure, do not try to free the machine until all personnel are removed from the platform.
- Do not increase the surface area of the platform or the load. Increase of the area exposed to the wind will decrease the stability.
- Do not increase platform size with unauthorised deck extensions or attachments.
- Do not raise the platform with the access apertures open. Keep the access apertures closed whilst the platform is raised.
- If the boom assembly or platform is caught so that one or more wheels are off the ground, all the persons and tools must be removed before attempting to stabilise the machine. Use a crane, forklift truck, or other appropriate equipment to stabilise the machine.

Crushing and Collision Hazards

- Approved head protection must be worn by all operating and ground personnel.
- Watch for obstructions around machine and overhead when driving. Check clearance above, to sides, at bottom of machine when lifting or lowering the platform.
- During operation, keep all body parts inside platform railing.
- Use the boom functions, not the drive function, to position the platform close to obstacles.
- Always post a lookout when driving in areas where vision is obstructed.
- Keep non-operating personnel at least 1.8m (71 inches) away from machine during all operations.
- Under all travel conditions, the operator must limit travel speed according to conditions of ground surface, congestion, visibility, slope, location of personnel, and other factors.
- Be aware of stopping distances in all drive speeds. Travel on slope or grades in low speed only.
- Do not use high speed drive in restricted or close quarters.
- Exercise extreme caution at all times to prevent obstacles from striking or interfering with operating controls and persons in the platform.
- Make sure that operators of other overhead and floor level machines are aware of the aerial work platform's presence. Position barriers around the floor if necessary.
- Do not operate over ground personnel. Warn personnel not to work, stand, or walk under a raised platform. Position barriers on floor as necessary.

If the cover pull switch is accidentally activated during machine operation, pull to reset it to its normal position. Refer to Figure 28. Refer to Figure 29.

Figure 28.

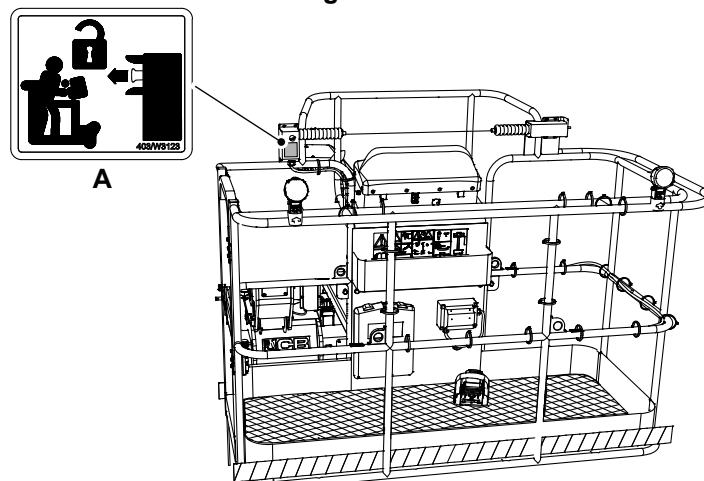

A Crush protection decal (located below the cover pull switch)

Figure 29.

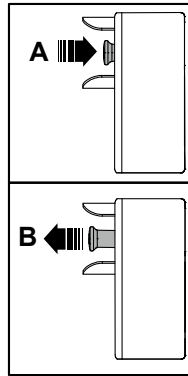

A Cover pull switch in activated position

B Cover pull switch in normal position

Platform Information Decals

The decals are located below the platform controller.

Figure 30. Decal Description

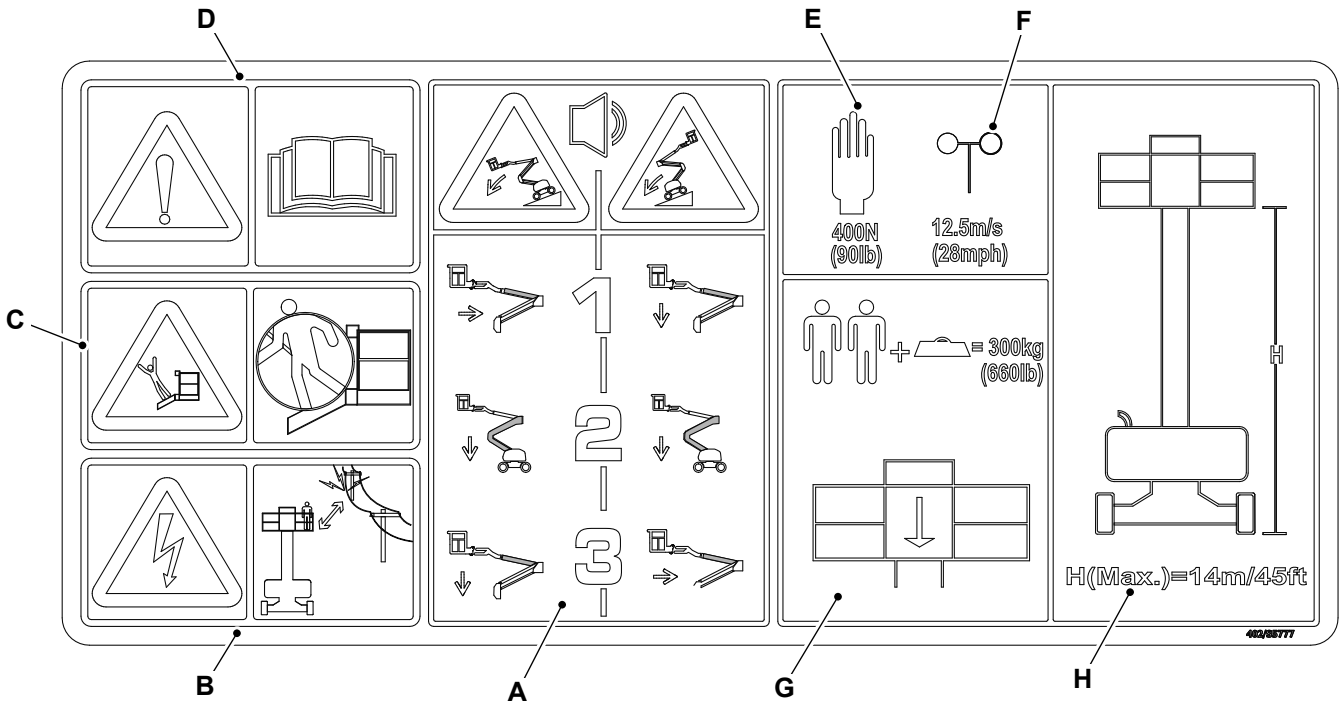

Table 7.

Items	Description
A	Warning. In the event of a stability hazard, lower the platform in the order shown, depending on the orientation of the machine on the slope.
B	Warning. Keep a safe distance from the overhead electrical cables.
C	Warning. Do not exit the platform at height. Do not walk or climb on the booms.
D	Warning. Read operator's manual before operating the machine.
E	Maximum manual force
F	Maximum wind speed
G	Maximum rated load on the platform
H	Maximum platform height

Auxiliary Electrics

General

▲ WARNING Electric shock hazard. High voltage can cause serious injury or death. Make sure that all work is performed by qualified personnel. All cabling to the load must comply with the applicable laws and electrical standards.

Notice: Possibility of equipment damage. Proper sizing is critical to the operation and performance of the generator. Make sure that the load is sized correctly for the capacity of your generator and cables.

WARNING Working with equipment that runs on Alternating Current (AC) could be dangerous. Any maintenance work on such equipment should be done by an authorised electrical engineer or a suitably trained person. All maintenance work must comply with IEC 60204-1 in Europe.

On mobile machines with on-board power supplies, the protective conductors, the conductive structural parts of the electrical equipment, and those extraneous-conductive-parts that form the structure of the machine must all be connected to a protective bonding terminal to provide protection against electric shock. The protective bonding terminal serves as the connection point for the external protective conductor when a mobile machine is connected to an external incoming power supply.

These machines are installed with generator or industrial plug kit with external power source.

The generator are compact and integrated all-in-one units. The generator is belt driven. These can be used to provide power to the platform when the machine is stationary. You must use equipment that is within the specified rated capacity of generator. [Refer to Table 8.](#)

Table 8.

Description	Data
Rated output	110V, 50Hz/60Hz
Rated Power	7.5 kVA
Rated Current	65A

The power plug is located at one end of the platform. [Refer to Figure 31.](#)

Figure 31. Platform

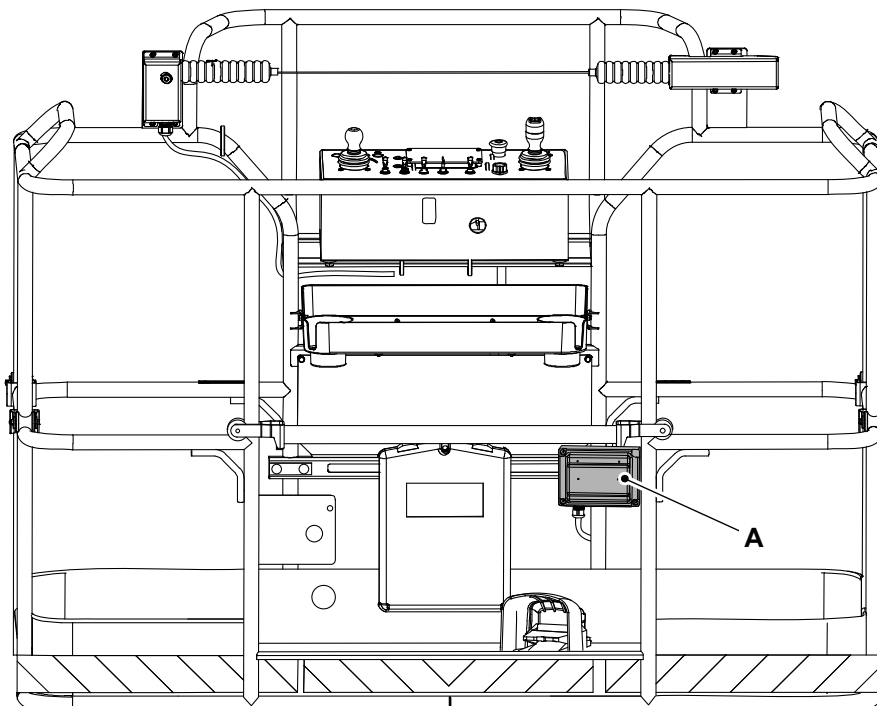

A Power plug

Changeover Box (110V)

Figure 32. Changeover Box (110V) - For UK

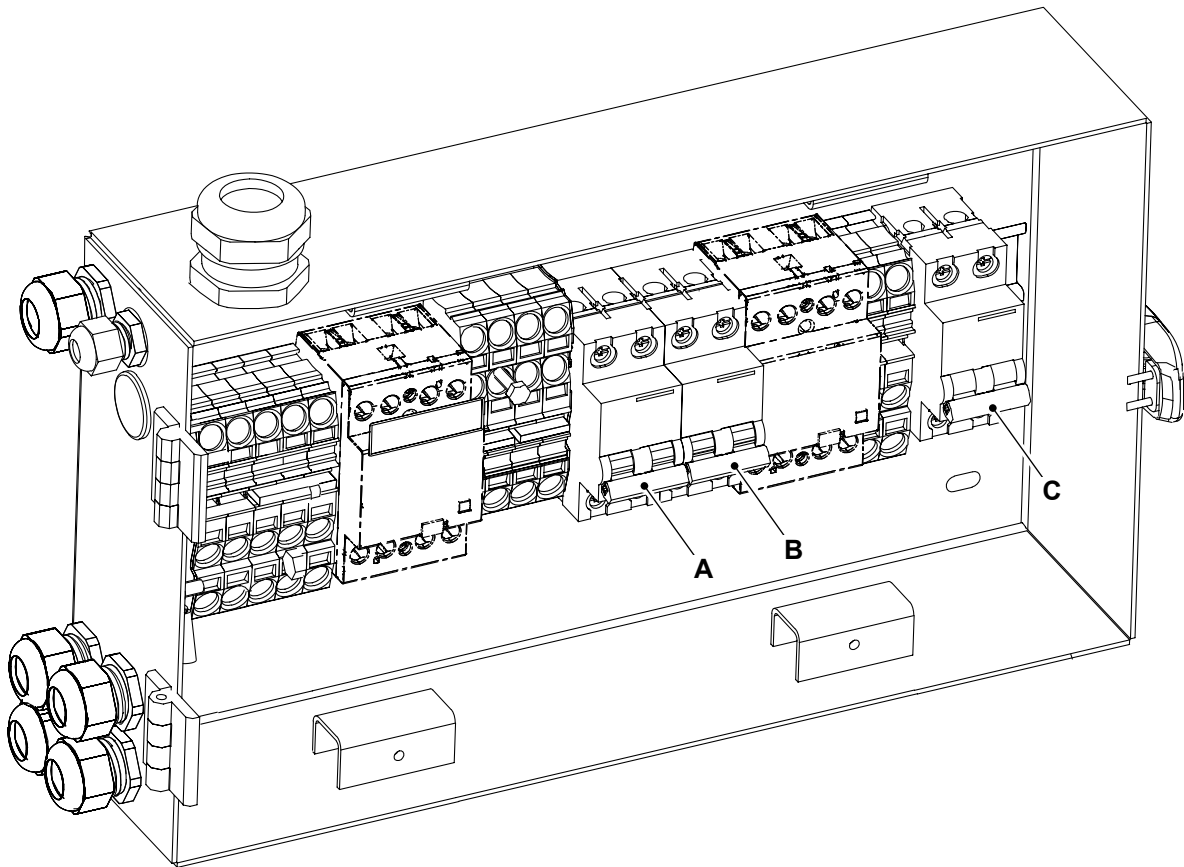

A RCBO (Residual Current Breaker with Over-Current) 1 - power to platform
C RCBO 3 - master charger (For hybrid and electric machines)

B RCBO 2 - slave charger (For hybrid machines only)

Figure 33. Changeover Box (110V) - For USA

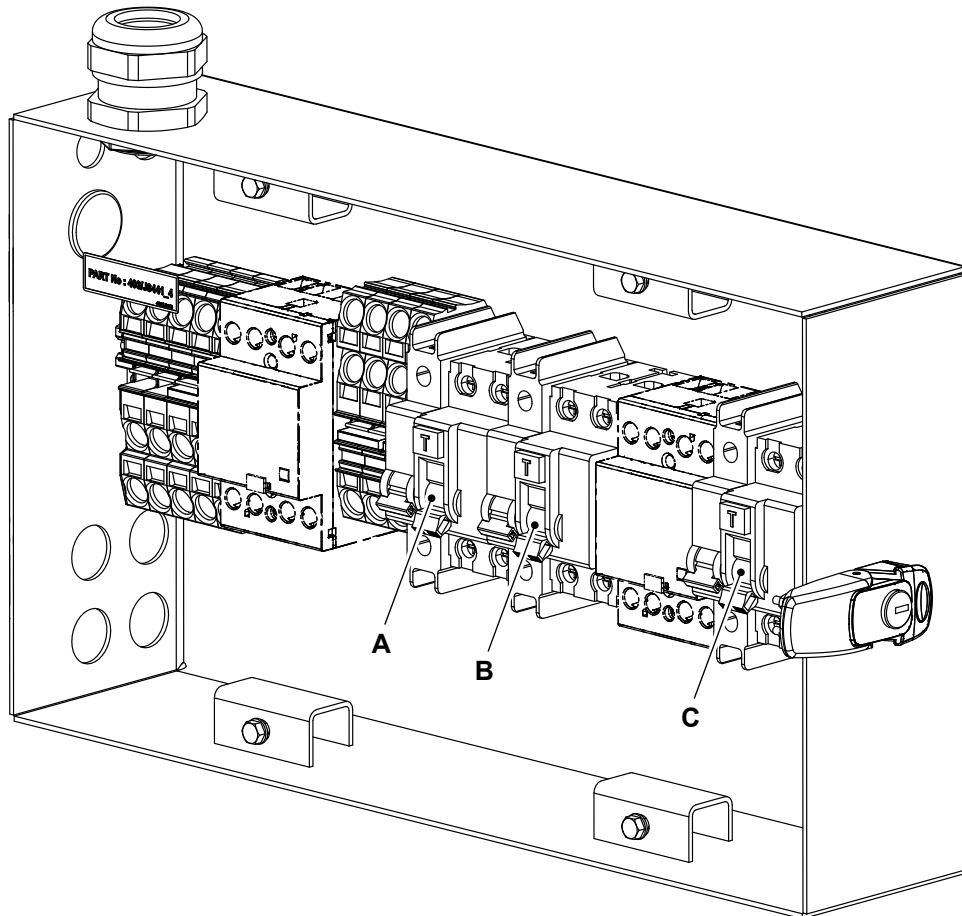

- A** RCBO 1 - power to platform
- B** RCBO 2 - slave charger (For hybrid machines only)
- C** RCBO 3 - master charger (For hybrid and electric machines)

The changeover box operates automatically as per the machine requirement and logic.

Do not operate the RCBO switches manually.

- The operator can either charge the batteries or operate the power to the platform function at a time.
- In the default mode, when the 3 phase AC power supply input is given to the changeover box from the alternator, it passes through the RCBO 2 and RCBO 3. The batteries will be charged through the master and slave chargers in this mode.
- If the power to platform switch is pressed on the platform control panel and the alternator is ON, then the AC power supply will be diverted to the platform to operate the power tools. The RCBO 1 will only be active in this mode.
- When the battery charging connector is connected to the external AC power supply, the batteries will get charged from the master charger only. The RCBO 3 will only be active in this mode.

Power to Platform

In the hybrid machine, the conventional approach to supply power to the platform is through an engine.

However, for the indoor applications, turning the engine ON, leads to a high amount of carbon emissions followed by excessive noise, which makes the environment unsuitable for working for the operators. To make the environment suitable, 'Zero Emission - Power to Platform' feature is available. Refer below section '(B) Zero Emission Option - For Indoor Application' for more information.

(A) Generator Option - For Outdoor Application

Figure 34. Power to Platform - Generator Option

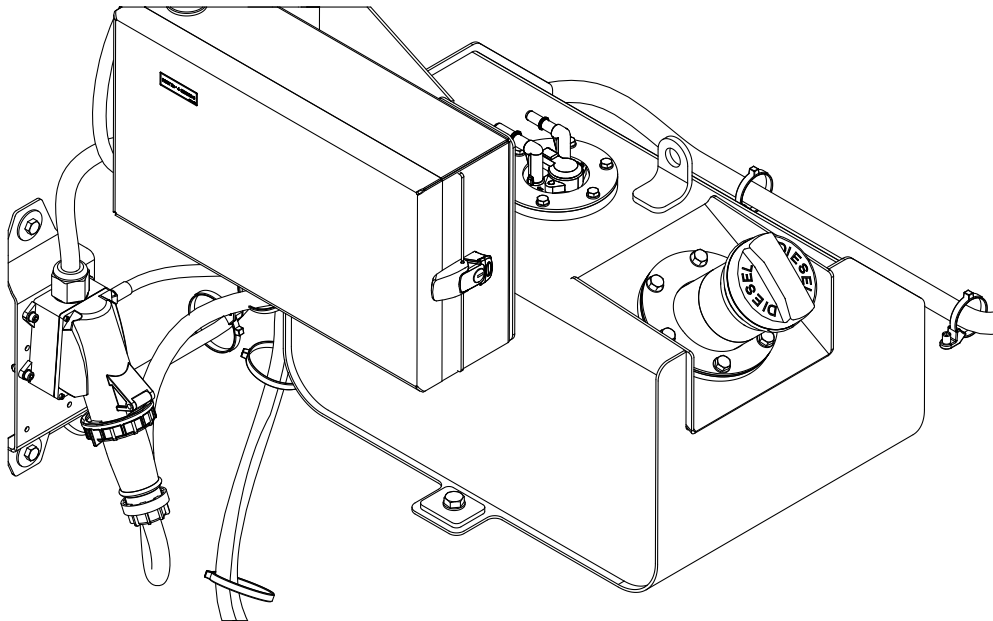

1. Make the machine safe.
[Refer to: Safety \(Page 3\).](#)
2. Turn the ignition key to the position 1.
3. Push the engine start/stop button on the platform control panel to start the engine.
4. Glow plug icon will pop up on the display until the engine starts. Auto start function is enabled by default.
5. Make sure that the generator canopy door is locked and the changeover box is closed.
 - 5.1. The canopy door should not be opened unless the machine ignition and isolator are switched OFF.
 - 5.2. It is recommended not to start the machine or run the generator when the canopy door is open.
6. Make sure that the foot pedal or base enable switch is not pressed when the power to platform is active.
7. If the foot pedal or base enable switch is pressed, power to platform will be switched OFF.
8. Visually inspect the connectors and wiring for damage daily or before use.
 - 8.1. If any damage to the AC cable is found, contact the JCB dealer.
9. Make sure to use compressed air to regularly clean the generator compartment of dust.

(B) Zero Emission Option - For Indoor Application

Figure 35.

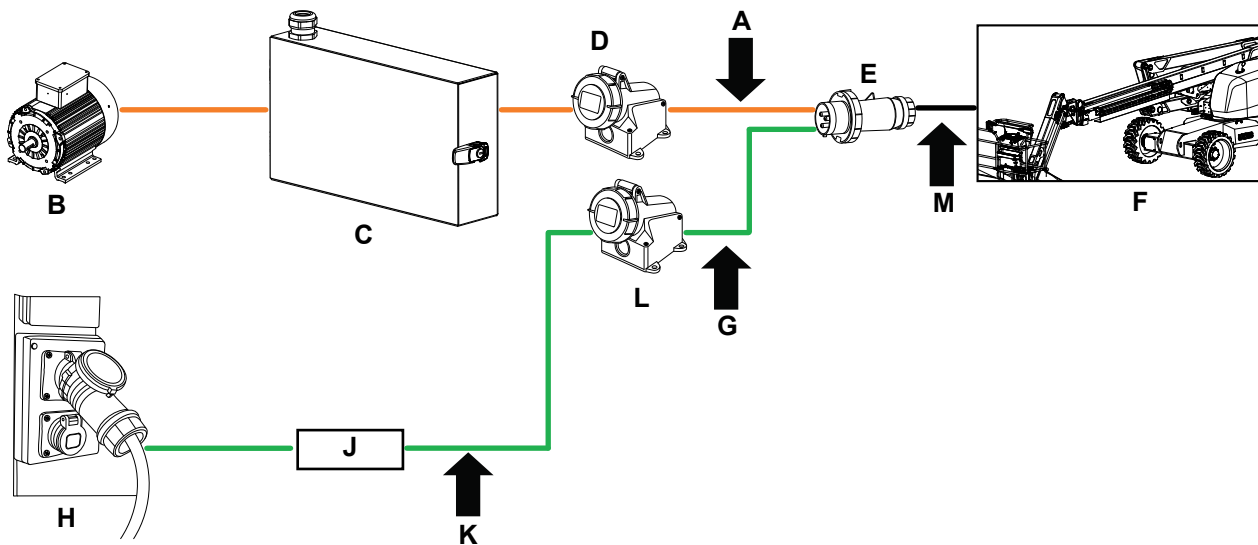

- | | |
|---|---|
| A Power to platform via engine (orange line) | B Generator |
| C Changeover box | D Socket (engine) |
| E Plug | F Power to platform socket |
| G Zero emission - Power to platform (green line) | H Wall socket |
| J RCD module | K External lead cable with RCD module |
| L Socket (zero emission) | M AC (Alternating Current) cable - Power to platform |

A new approach to indoor applications has been introduced, 'Zero Emission - Power to Platform', which uses external leads from wall sockets to supply power to the platform. It is recommended that the operator should obtain the necessary external leads from the JCB dealer/service to avoid any electrical hazards within the machine. An internal protective circuit module is present in these external leads, which safeguards against short circuit and over current conditions.

For outdoor applications, supplying power to the platform is still through an engine. Refer section '(A) Generator Option - For Outdoor Application' for more information.

The default setting for 'Power to Platform' will be through an engine. In case of indoor application, the operator needs to disconnect the engine socket and connect the wall socket with the plug.

When 'Zero Emission Power to Platform' is active, the operator must make sure that the following points are considered.

- Make sure that you do not run the engine.
- Make sure that you do not drive the machine.
- It is not recommended to press the 'Power to Platform' acknowledgement button as power is available directly on the platform.

Power to Platform - Industrial Plug Kit Option

Some machines are equipped with industrial plug kit with external power source with input socket at turntable structure and output plug at the platform.

Table 9.

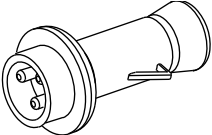
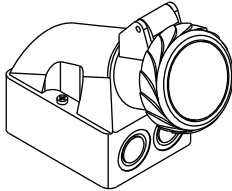
Description	Chassis End	Platform End
Standard		

Worklights (If Installed)

Worklight is a high intensity light fixture which provides user with optimum lighting conditions to work even in dark conditions. This is an optional feature and fitted on customer demand or can be a dealer fit kit.

To operate the worklight from the platform control panel follow the steps below:

1. Make the machine safe.
[Refer to: Safety \(Page 3\).](#)
2. Turn the machine ON and press the worklight switch from the platform control panel.
 - 2.1. The worklights will turn ON.
[Refer to: Instrument Panel \(Page 28\).](#)
3. To turn OFF the work light, press the work light switch from the platform control panel.

Figure 36.

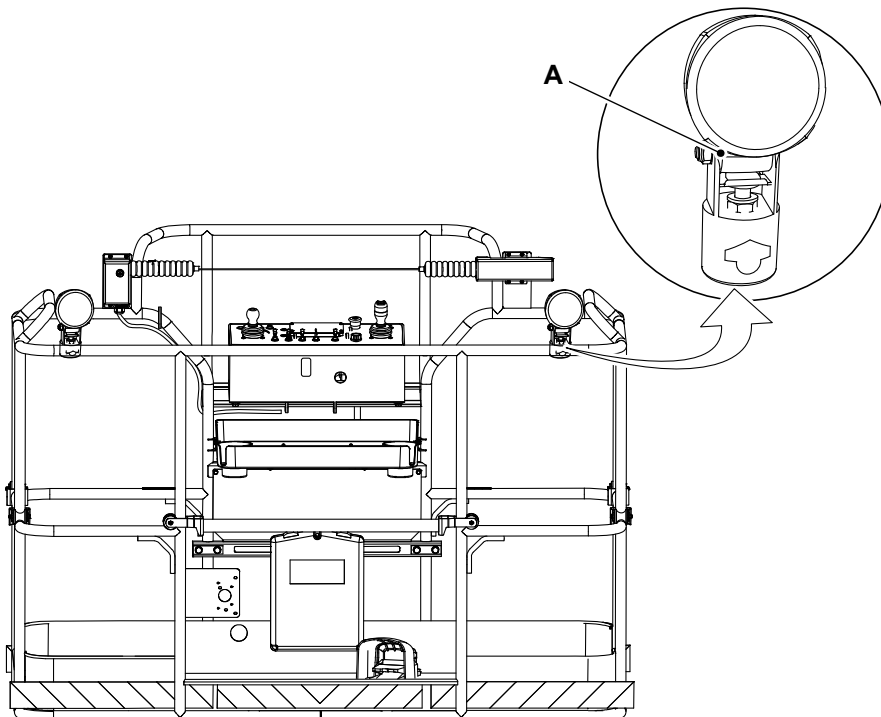

A Worklight

Platform Protective Conductor

All the protective conductor shall be connected to a protective bonding terminal to provide protection against electric shock.

Figure 37.

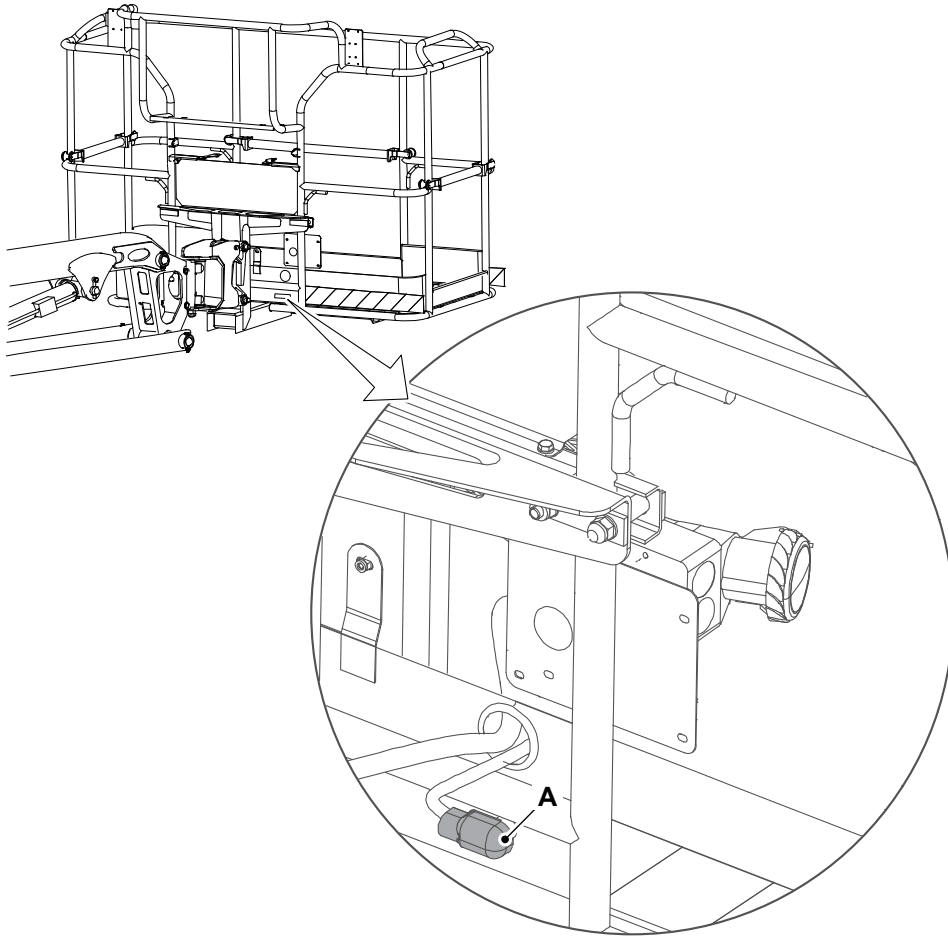

A Platform protective conductor

Moving a Disabled Machine

General

▲ WARNING Do not use the platform controller to release the platform when it is stuck, snagged or caught. In this case, use the ground controller only when there are no persons on the platform.

Notice: Following any incident, thoroughly inspect the machine. Do not raise the platform until you are sure that all damage has been repaired and that all controls are operating correctly. Test all functions first from the ground controller, then from the platform controller.

The operator can lower the platform in the event of an emergency.

Boom functions may be powered by the auxiliary battery. This method of operation is intended for recovering a disabled machine in the event that operation from the main batteries is not possible.

If the machine becomes disabled, the machine must be made safe, lifted onto a transporter and moved to a location where it can be repaired.

Towing, winching or pushing the machine without following the correct procedure may damage parts of the machine. If possible, repair the disabled machine where it stands.

Lower the Platform

Powerpack malfunction (Battery low, short circuit etc).

Operation From the Base Control

1. Pull out the emergency stop button.
2. Press and hold the selection switch to base control position.
3. Continue to hold the selection switch, so that the machine can operate from the ground position and activate the desired boom function.

Operation From the Platform Control

1. Pull out the emergency stop button.
2. Press down the foot pedal switch.
3. Select the auxiliary power ON / OFF button and activate the desired boom function.

Lower the Platform (Emergency Operation)

Override control must be used in the event of an emergency only. A service engineer should be called to reset the emergency override display alert triggered by using base override. If the override control has been used because the platform has been overloaded, the machine should be inspected for any structural damage, and the overload system should be re-calibrated according to the instructions in the service manual. This override should not be used to intentionally lift or lower loads heavier than the maximum rated platform load. If the platform is overloaded, the excess weight must be removed from the platform before lowering the platform. When override is used, the booms should be operated in order to return the machine to a safe working condition.

In case of a false overload situation, the operator can use the platform override feature to recover the machine.

False overload is if the load on the platform is known to be below the maximum permissible allowed, but the overload warning is active.

Operation From the Base Control

1. Turn the ignition key to the OFF position.
2. Pull out the emergency stop button.
3. Press and hold the red emergency override button.
4. Turn the ignition key to the ON position.

5. Caution light will flash and a buzzer will beep from both control positions. The ground control display will indicate "emergency override" condition has been activated.
6. Continue to hold the red emergency override button and activate the desired boom function.

Operation From the Platform Control

1. Press the foot pedal switch and keep it pressed.
2. Press and hold the AUX button.
 - 2.1. The engine will stop automatically if it's running and an 'Emergency Override Active' message will appear on the display.
 - 2.2. The machine alarm will sound for 2s and mute for 2s.
3. Continue to hold the emergency override button and operate the desired boom function.
4. Release the AUX button.
 - 4.1. Now, the normal machine operation can be resumed.

Emergency Stop System

The machine have an emergency stop at both base and platform control panels. When either of the emergency stop is pressed, it prevents engine start.

Emergency Stop from Base Control Panel

1. When the base emergency stop button is pressed, it stops the power supply to the machine (i.e. displays etc.).
[Refer to: Basic Controls \(Page 40\).](#)
2. When the base emergency stop is pressed, it cannot be overridden by the base override.
3. When the base emergency stop button is released/unpressed, make sure that all the desired functions work correctly.

Emergency Stop from Platform Control Panel

1. When the platform emergency stop button is pressed, it stops the power supply to the machine (i.e. displays etc.).
[Refer to: Basic Controls \(Page 40\).](#)
2. When the platform emergency stop is pressed, it can be overridden by the base override.
3. When the platform emergency stop button is released/unpressed, make sure that all the desired functions work correctly.

Manual Brake Deactivation

▲ WARNING Do not keep the brake deactivated for a duration more that 30 minutes. Before towing the machine perform a risk assessment and make sure there is a safe method of stopping the machine since the machine brakes will not be available.

Manual brake deactivation is required when there is machine failure and the machine needs to be towed to a safe maintenance site. Do not tow the machine for a distance more than 200m. Before towing make sure that the oil level in the hub is appropriate.

Make a note that after towing operation install the disengage cap in its original position on all four hubs.

1. Make the machine safe.
[Refer to: Safety \(Page 3\).](#)
2. Remove the screw (x2).

3. Remove the disengage cap from the hub.
4. Flip the disengage cap and install to the hub.
5. Tighten the screw (x2).
6. Repeat steps 1 to 5 to other hubs.

Figure 38.

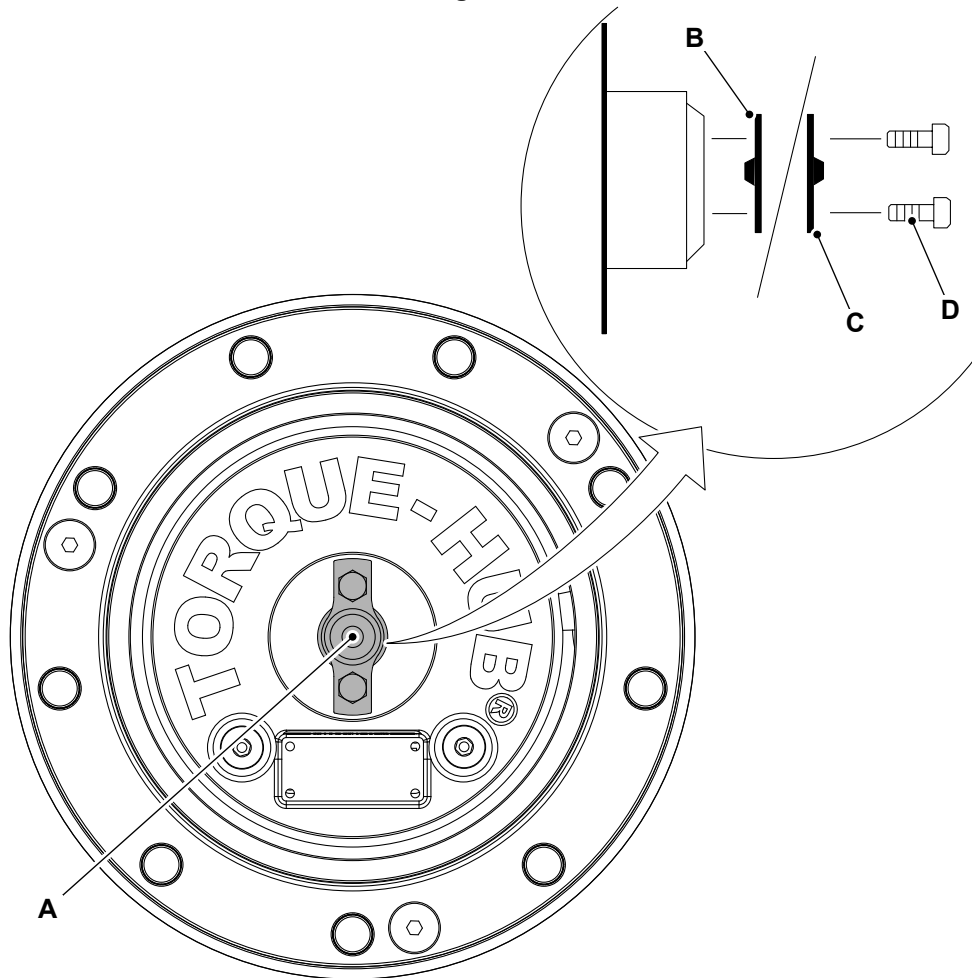

- | | |
|---|--|
| A Disengage cap | B Disengage cap (brake disengaged position) |
| C Disengage cap (brake engaged position) | D Screw (x2) |

Lifting the Product

General

Lifting points are provided for lifting the machine. Using these points will give a safe stable lift. Other methods of lifting are not recommended.

Refer to: [Lifting Points \(Page 55\)](#).

Lifting Procedure

1. Make the machine safe with the platform lowered.
2. Remove any loose items from the machine.
3. Make sure all the access covers and canopies are securely shut.
4. Use an appropriate length of lifting equipment to prevent damage to the platform base and guardrail.
5. Make sure the hoist rigging is in the correct position. Adjust the hoist rigging to prevent machine damage and keep the machine in the level position.

- 5.1. You must consider the location of the centre of gravity on the machine, when you lift the machine. The centre of gravity is located at a point on the ground, at the centre of front axle.

Refer to: [Lifting Points \(Page 55\)](#).

- 5.2. Use foam to protect the booms and counterweight at suitable contact points to avoid damage.

The machine should be in the fully stowed position in 0° slewing position and in the forward drive position. If necessary, slew the machine to 5° which will let the vertical chains lift the machine without impacting the boom structure.

Lifting Points

Figure 39.

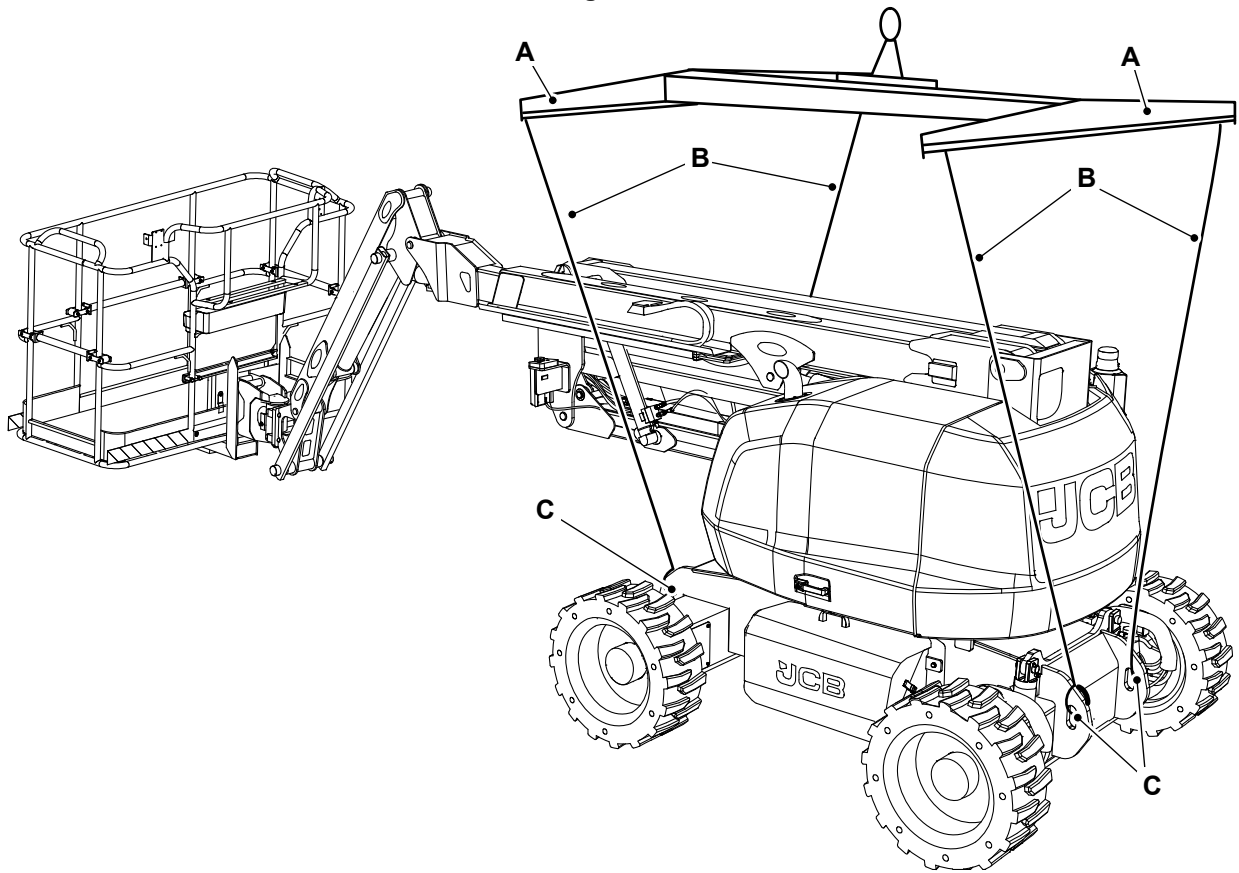

A Spreader bars
C Lifting points

B Lifting chains

Figure 40.

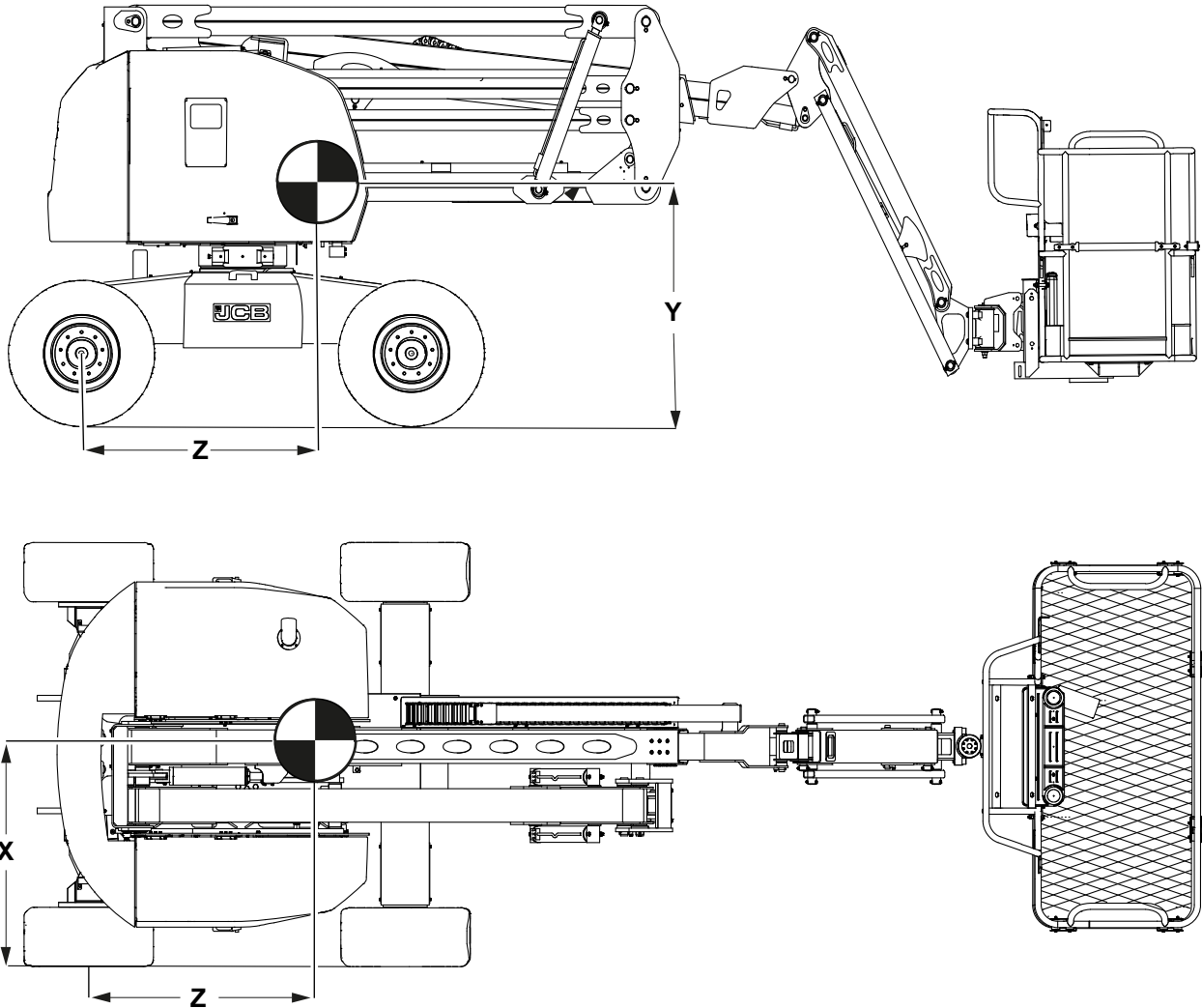

Table 10. Location of the Centre of Gravity

X- axis	Y- axis	Z- axis
1,082.5mm	1,062mm	1,086.3mm

Transporting the Product

General

▲ WARNING The safe transit of the load is the responsibility of the transport contractor and driver. Any machine, attachments or parts that may move during transit must be adequately secured.

CAUTION Before moving the machine onto the trailer, make sure that the trailer and ramp are free from oil, grease and ice. Remove oil, grease and ice from the machine tyres. Make sure the machine will not foul on the ramp angle.

Check the condition of the transport vehicle before the machine is loaded on to its trailer.

Make sure that the transport trailer is suitable for the dimensions and weight of your machine.

Before transporting the machine make sure you will be obeying the local rules and laws regarding machine transportation of all the areas that the machine will be carried through.

Loading onto the Transporting Vehicle

Lifting the Machine onto the Transporting Vehicle/Trailer

1. Place the boom and jib in the stowed position.
2. Turn off the machine and remove the key.
3. Remove any loose items from the machine.
4. Engage the slew lock pin. [Refer to Figure 41.](#)

Figure 41.

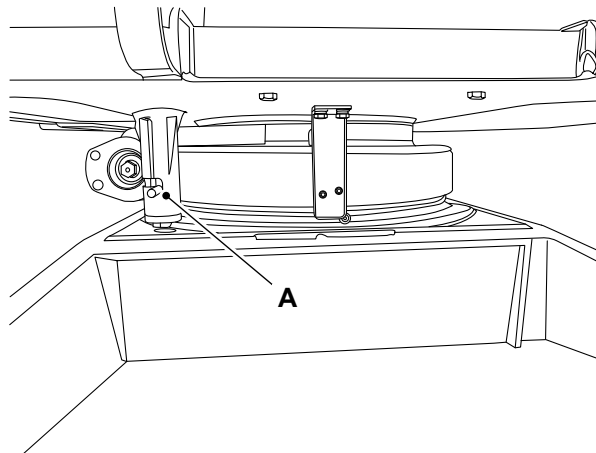

A Slew lock pin

5. Place the wheel chocks at the front and rear of the trailer wheels.
6. Lift the machine on to the trailer.
7. Put wheel choke blocks at the front and rear of all four wheels. Make sure they are securely in place.
8. Measure the maximum height of the machine from the ground. Total height should comply with regulations for transportation. Make sure the truck driver knows the clearance height before he drives away.
9. Secure the chassis to the trailer bed with suitable restraint. Use the tie down points indicated by the safety decals.

[Refer to: Tie Down Points \(Page 58\).](#)

10. Secure the platform with strap placed over the platform mount near the platform rotator. The platform should rest on a block during transportation. Do not use excessive downward force when securing the boom section.

Refer to: [Tie Down Points \(Page 58\)](#).

Driving the Machine onto the Transporting Vehicle/Trailer

1. Put the blocks at the front and rear of the trailer wheels.
2. Lower the ramps and check for suitability. Ramp should be with less than 40% gradient.
Refer to: [Performance Dimensions \(Page 151\)](#).
3. Make sure that the machine load distribution is correct.
Refer to: [General \(Page 38\)](#).
4. Put wheel chock blocks at the front and rear of all four wheels. Make sure they are secured in place.
5. Turn the machine off and remove the key.
6. Remove any loose items from the machine.
7. Engage the slew lock pin. Refer to [Figure 41](#).
8. Measure the maximum height of the machine from the ground. Make sure the truck driver knows the clearance height before he drives away.
9. Secure the machine to the trailer bed with suitable restraint. Use the tie down points indicated by the decals.
Refer to: [Tie Down Points \(Page 58\)](#).

Tie Down Points

Figure 42. Machine Tie Down Points

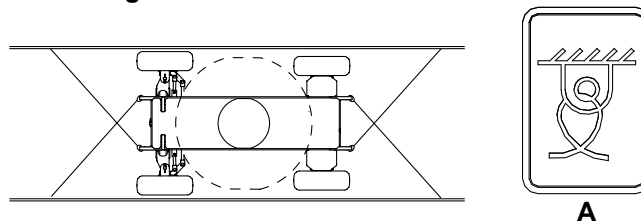

A Tie down decal

Figure 43. King Post Tie Down Point (Side View)

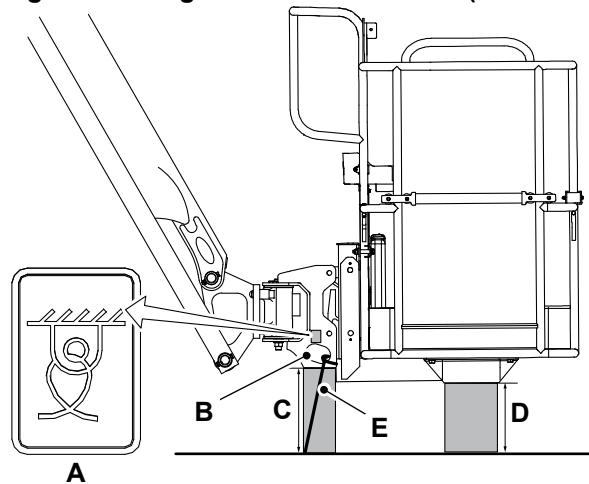

A Tie down decal

C Height of wooden block (including rubber pad) below king post - 250mm (x1)

E Ratchet belt

B Tie down point

D Height of wooden block (including rubber pad) below platform - 170mm (x2)

Figure 44. Platform Tie Down Point (Front View)

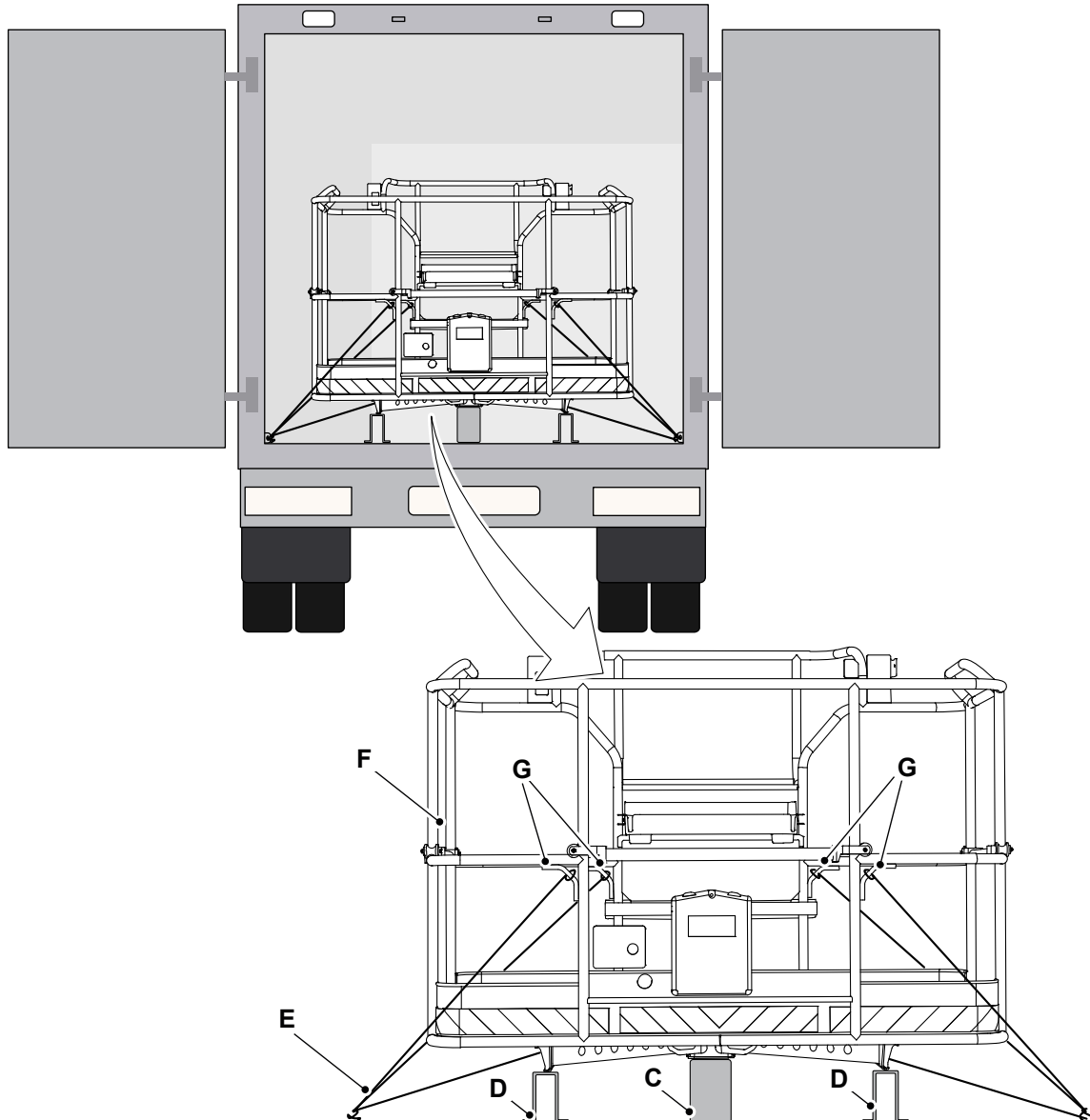

C Height of wooden block (including rubber pad) below king post - 250mm (x1)

E Ratchet belt
G Anchorage point (x4)

D Height of wooden block (including rubber pad) below platform - 170mm (x2)

F Platform

Tie-Down Procedure

1. Park the machine within the container.
2. Correctly position and secure the wooden blocks (including rubber pad) below the king post and the platform. Refer to Figure 43.
3. Make sure to rest the main boom on the resting pad and level the platform horizontally.
4. Lower the platform using the jib down operation to rest the king post on the 250mm wooden block (including the rubber pad). Refer to Figure 43. Refer to Figure 44.
 - 4.1. To support the platform carrier, two wooden blocks with a height of 170mm must be placed below it. They must have the same height and the carrier should rest on them. Refer to Figure 43. Refer to Figure 44.

5. If necessary, make sure to place white foam on the platform gate to prevent any metal to metal contact.
6. Do the steps that follow to tie down the machine:
 - 6.1. Cross lash the tie-down points of the machine to the side wall hooks on the container floor. [Refer to Figure 42.](#)
 - 6.2. Securely lash the tie-down point of the king post to the side wall hooks on the container floor. [Refer to Figure 43.](#)
 - 6.3. Cross lash the anchorage points of the platform to the side wall hooks on the container floor. [Refer to Figure 44.](#)

Operating Environment

General

In low and high temperature conditions, take the following precautions. This will prevent possible damage to your machine.

The machine has been designed to operate in atmospheric temperatures between -12°C (10°F) and 46°C (115°F). When the ambient temperature is below 0°C (32°F), the hydraulic oil will need to be heated before operating the services.

Operating in Low Temperatures

1. Use the correct grade of hydraulic oil.
[Refer to: Fluids, Lubricants and Capacities \(Page 156\).](#)
2. Keep all the battery at full charge.
3. Protect the machine when its not in use. Park the machine inside a building or cover it with a tarpaulin.

Operating in High Temperatures

1. Keep the hydraulic oil / fluid at the correct level. Make sure there are no leaks.
2. Use the correct grade of hydraulic oil.
[Refer to: Fluids, Lubricants and Capacities \(Page 156\).](#)
3. Check the air vents. Make sure that the air vents to and from the battery compartment are not blocked.
4. Keep all the battery at full charge.

Refuelling

General

▲ **CAUTION** Spilt fuel may cause skidding and therefore accidents. Clean any spilt fuel immediately.

Do not use fuel to clean the machine.

When filling with fuel, choose a well aired and ventilated area.

Notice: Consult your fuel supplier or JCB dealer about the suitability of any fuel you are unsure of.

Filling the Tank

Before you add the fuel to the machine,

[Refer to: Fluids, Lubricants and Capacities \(Page 156\)](#). If you use the incorrect type of fuel or fuel which is contaminated, then damage to the fuel injection system can occur.

WARNING! Do not use petrol in this machine. Do not mix petrol with the diesel fuel. In storage tanks the petrol will form flammable vapours.

At the end of every working day, fill the tank with the correct type of fuel. This will prevent overnight condensation from developing in the fuel.

1. Make the machine safe.
[Refer to: Maintenance Positions \(Page 91\)](#).
2. Remove all unwanted material around the fuel cap.
3. Remove the fuel cap.
[Refer to: Service Points \(Page 92\)](#).
4. Add the fuel through the filler neck as necessary.
5. Install the fuel cap.
6. Lock the fuel cap to prevent theft and tampering.

Attachments

Working with Attachments

Attachments for your Machine

The machine can be equipped with optional attachments. [Refer to Table 11](#). Contact your JCB dealer for more details.

Table 11. Optional Attachments

Reflector	Refer to: General (Page 64).
Half mesh	Refer to: General (Page 65).
Console shield	Refer to: General (Page 66).
Worklight	Refer to: General (Page 67).
Pipe cradle post	Refer to: General (Page 68).
Safety strut	Refer to: General (Page 72).
Wheel nut indicator	Refer to: General (Page 73).
Smart white alarm	Refer to: General (Page 74).

Reflector

General

Reflector

This are used to enhance visibility by reflecting ambient light, thereby improving detection and reducing the risk of collisions in low-light or high-traffic environments.

Figure 45.

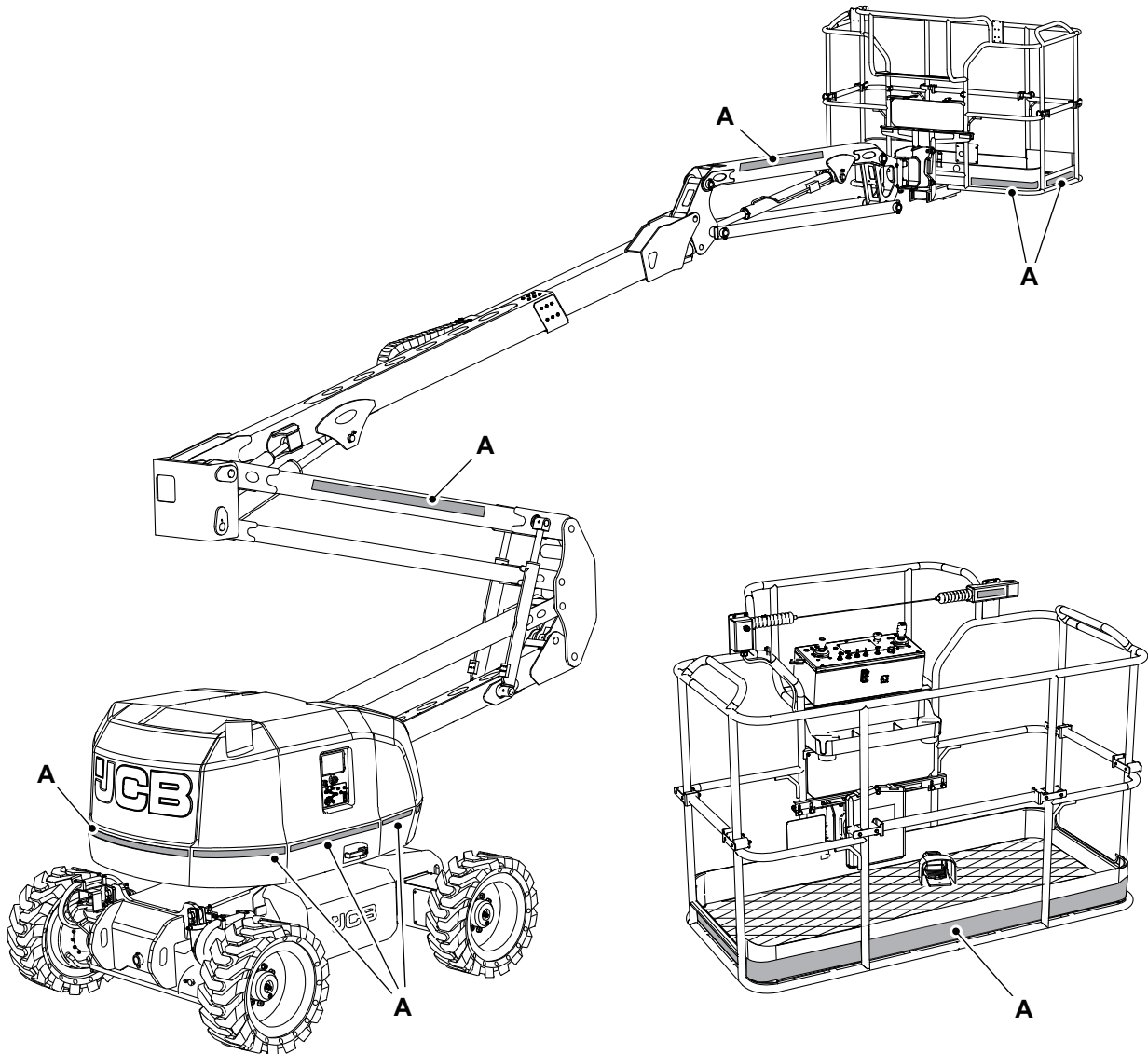

JCB © CONNOR STANMORE - 13/03/2026 07:54.

Half Mesh

General

Half Mesh

The half mesh is used to cover the lower half of the boom platform area, from the floor to the mid-rail.

Figure 46.

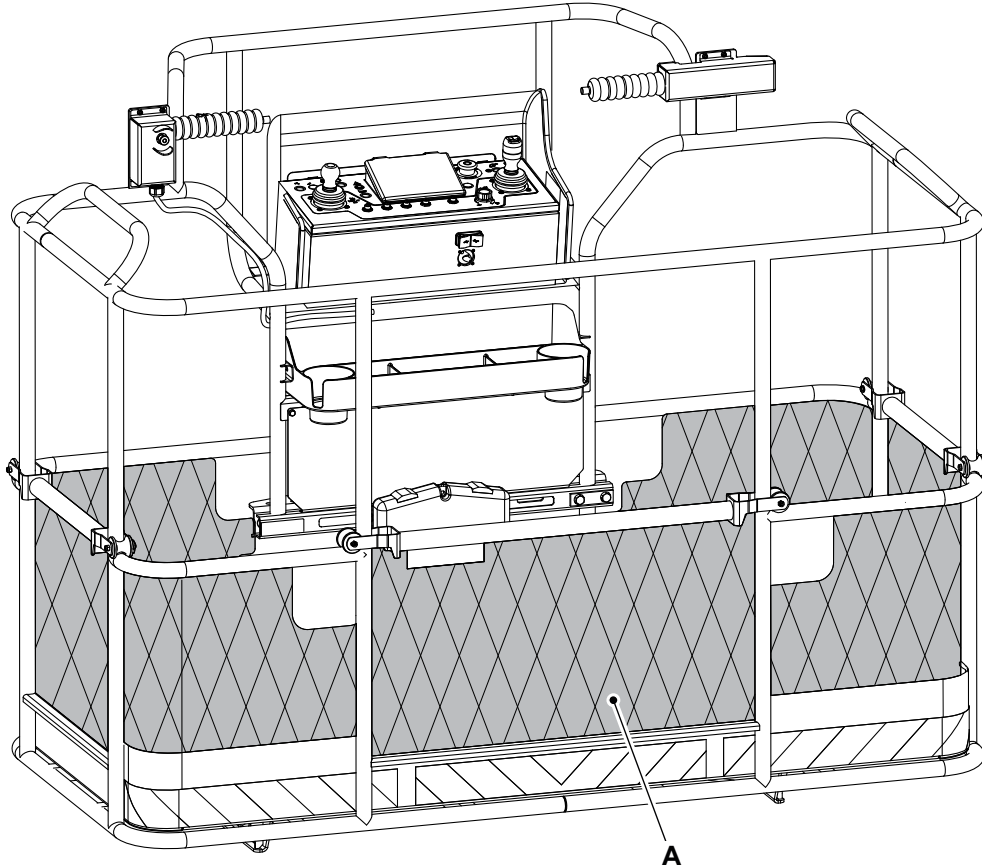

A Half mesh

1. It is recommended to assemble the half mesh after calibrating the load sensor to prevent the weight of the half mesh from compromising the payload.

Console Shield

General

Console Shield

The console shield is mounted on the platform along with the control panel. It protects the control panel from direct sunlight and potential damage caused by falling tools.

Figure 47.

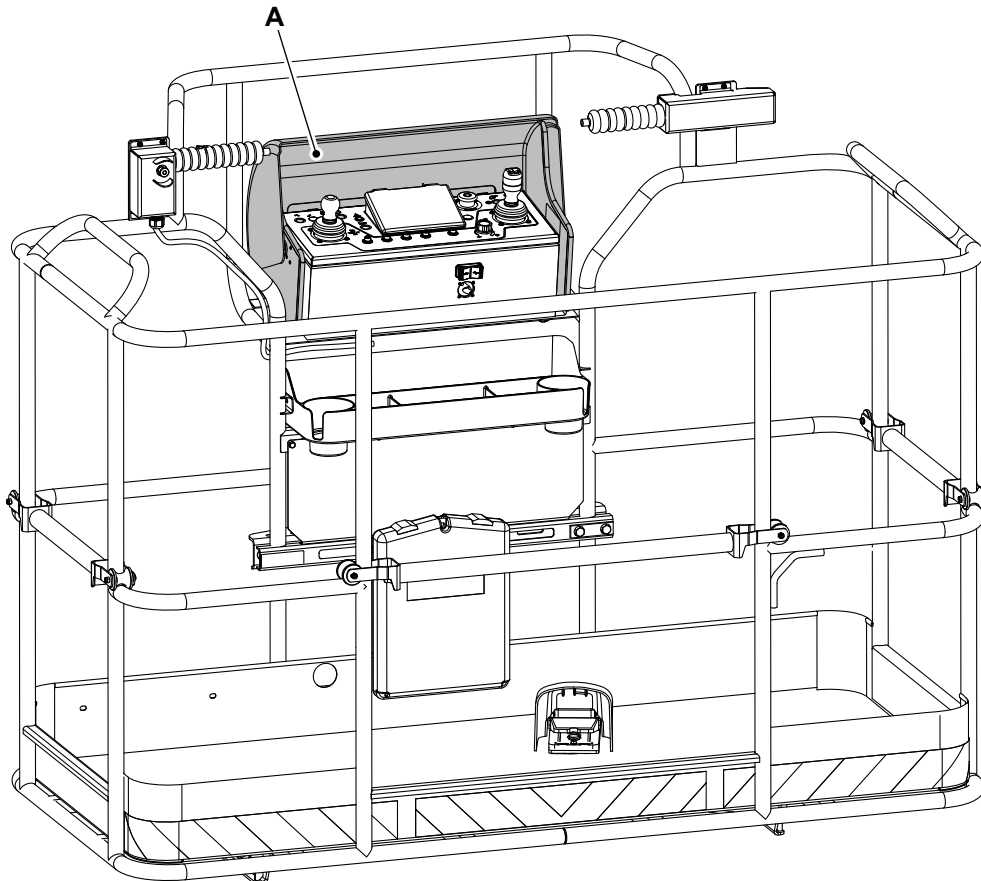

A Console shield

Worklight

General

Worklight

The worklight is installed to improve productivity in low-light conditions.

Figure 48.

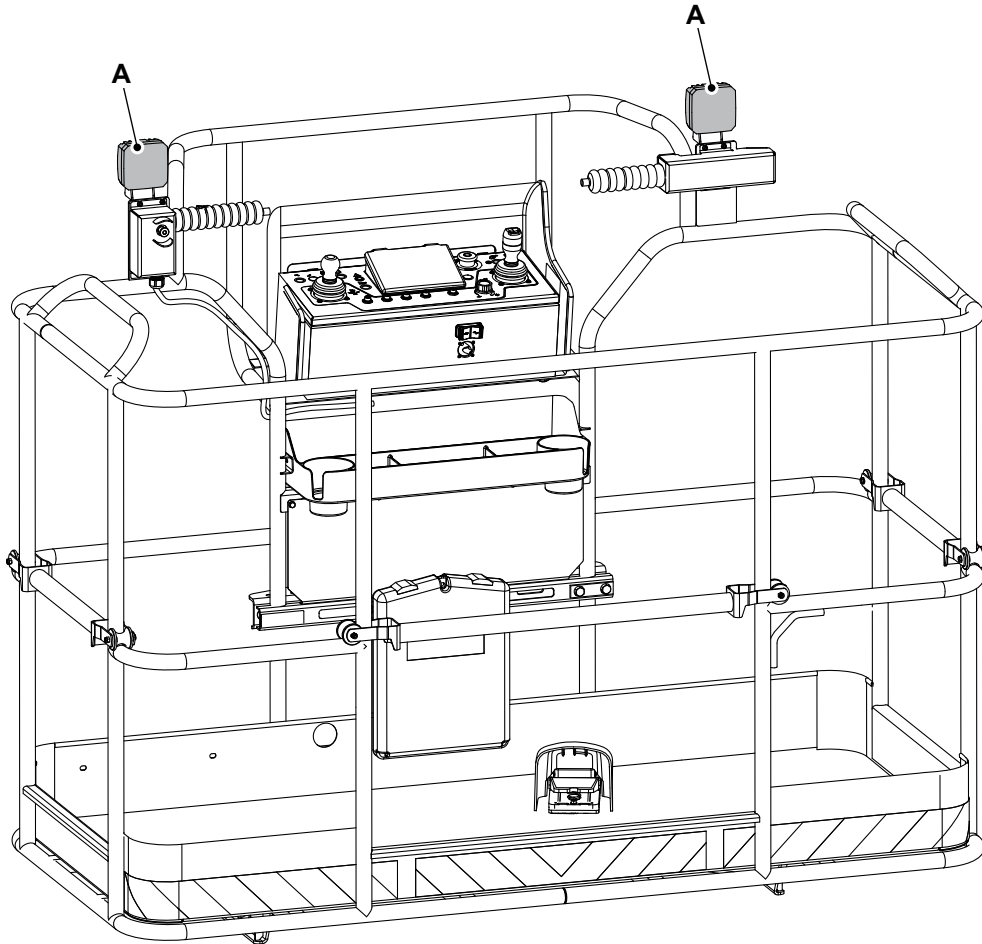

A Worklight

Pipe Cradle Post

General

Pipe Cradle post

Manually navigate to the JCB Service Pro and search for '9814/2600' to locate comprehensive installation and safety guidelines for fitting the 'Pipe Cradle Post' attachment kit.

Pipe cradle post allows carrying pipes or conduits inside the platform to optimise its utility.

It consists of two cradles attached to the fixed platform rails. Refer to Figure 49. Provision to use the straps is provided on the cradle to secure the load in place.

Figure 49.

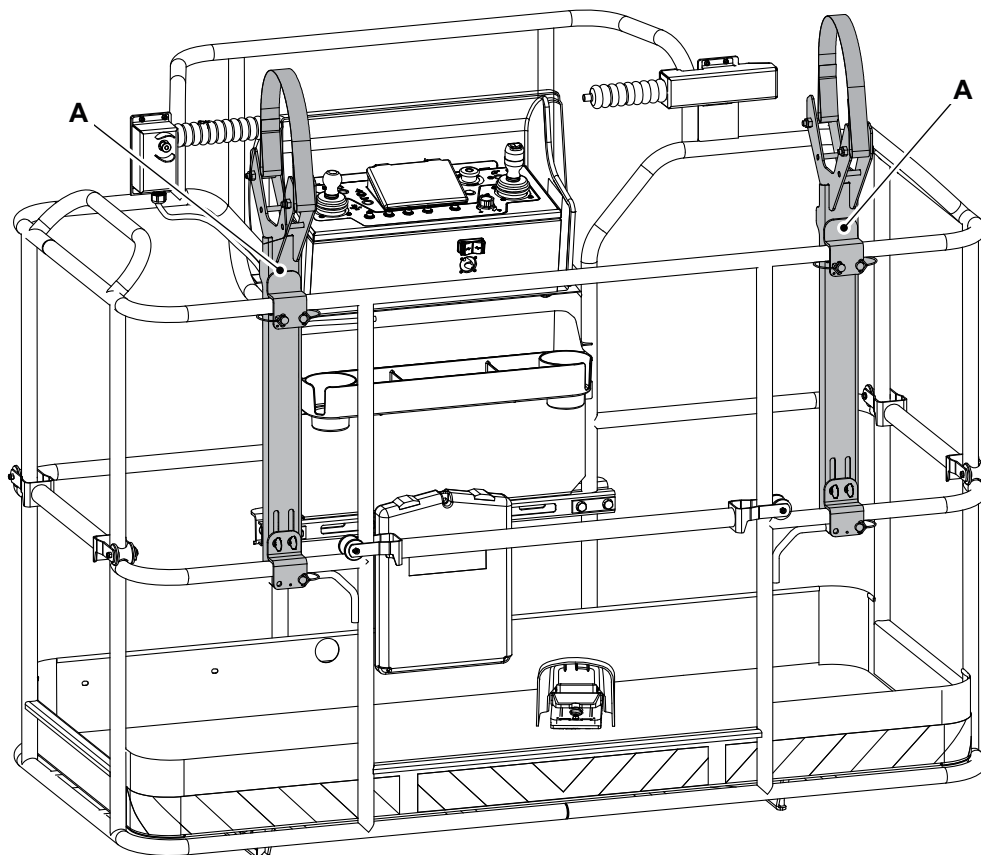

A Pipe cradle post

Figure 50. Pipe Cradle Post Decals

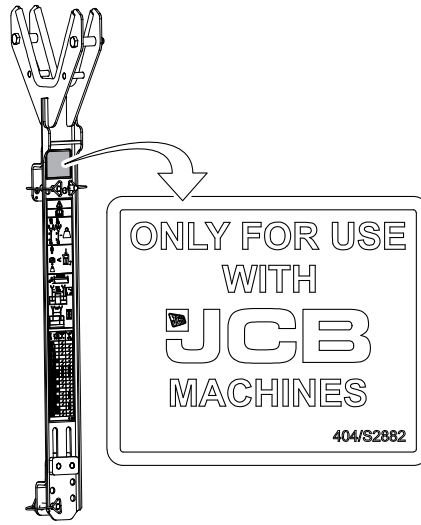
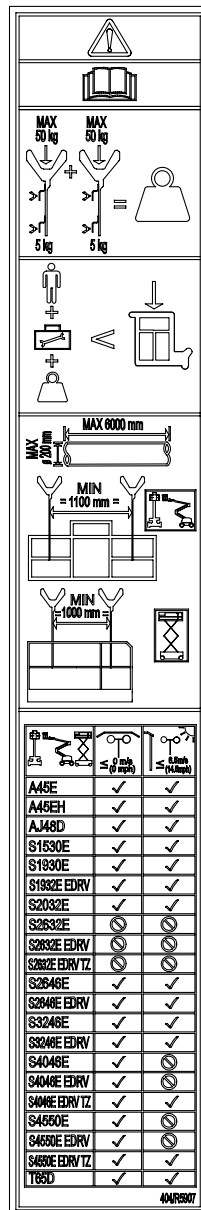

Figure 51.



Note

- Pipe cradle post can be use indoor/outdoor as per instructions mentioned on decal.
- The pipe cradle post, when fitted on the platform, is included in the overall rated capacity of the platform.
- Make sure that the weight of the pipe cradle post, weight on the pipe cradle plus the weight on the platform must not exceed the overall rated capacity of the platform.
- The weight of the pipe cradle is 10kg with the maximum load capacity of 100kg on both the cradles (which must not exceed 50kg per cradle).
- Retract the platform extension before attaching the pipe cradle post and loading material.

Operation

1. Check and make sure that both the cradles are mounted and fastened securely inside the platform rails using the thumb screws and shaft locking pins.

Check (Condition)

1. Check that the safety and instructional labels are in place and undamaged.



- 1.1. Contact JCB dealer to replace damaged labels with new ones when required.
2. Check for missing or damaged components. Replace, if necessary.
3. Check the condition of fasteners. Replace, if necessary.
4. Make sure that the load is secured with the straps during any movement of the machine.

Safety Strut

General

Safety Strut

While performing maintenance when the machine is in the raised position, it is important to install the safety struts on the articulated lift cylinders.

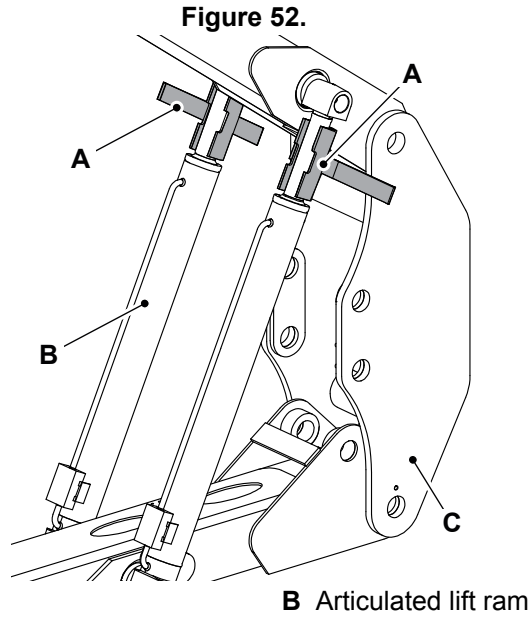

A Safety strut
C Front knuckle

B Articulated lift ram

Wheel Nut Indicator

General

Wheel nut indicator

The wheel nut indicator helps to detect loose nuts quickly. If the indicators shift from their original position, it signals that a nut may have loosened, improving safety and inspection efficiency.

Figure 53.

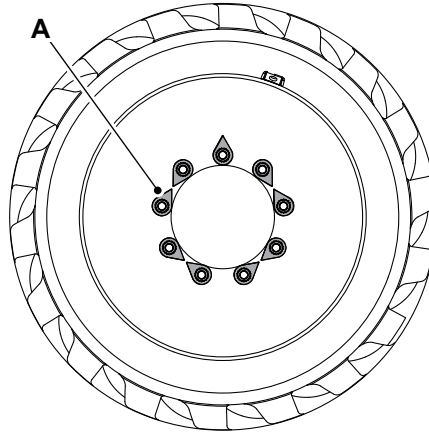

A Wheel nut indicator

Smart White Alarm

General

Smart White Alarm

Smart white alarm actively monitors ambient noise levels and dynamically adjusts its alarm output to ensure sufficient auditory warning around the machine during operation.

Figure 54.

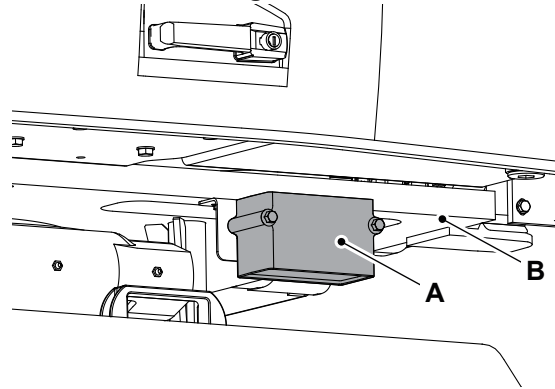

A Smart white alarm

B Turntable

Preservation and Storage Cleaning

General

▲ **WARNING** When using cleaning agents, solvents or other chemicals, you must adhere to the manufacturer's instructions and safety precautions.

WARNING Airborne particles of light combustible material such as straw, grass, wood shavings, etc. must not be allowed to accumulate within the battery compartment. Examine these areas frequently and clean at the beginning of each work shift or more often if required. Before opening the battery cover, make sure that the top is clear of debris.

CAUTION To avoid burning, wear personal protective equipment when handling hot components. To protect your eyes, wear goggles when using a brush to clean components.

Notice: Cleaning metal parts with incorrect solvents can cause corrosion. Use only recommended cleaning agents and solvents.

Notice: The efficiency of the rams will be affected if they are not kept free of solidified dirt. Clean dirt from around the rams regularly. When leaving or parking the machine, close all rams if possible to reduce the risk of weather corrosion.

Notice: Never use water or steam to clean the platform controls. The use of water or steam could damage the machine electrics and render the machine inoperable. Remove dirt using a brush or damp cloth.

Clean the machine with water and/or steam. Do not let mud, debris etc. to collect on the machine.

Before you do any service procedures that require components to be removed:

- The cleaning must be done either in the area of components to be removed, or in the case of major work, the whole machine must be cleaned.
- When cleaning is complete, move the machine away from the wash area or alternatively, remove the material washed from the machine.

When you remove components, be aware of exposure to dirt and debris. Cover any open ports and remove the deposits before proceeding.

Refer to the individual clean procedures throughout the Maintenance section.

[Refer to: Maintenance Schedules \(Page 85\).](#)

Detergents

Do not use a full strength detergent. Always dilute the detergents as per the manufacturer's recommendations, or damage to the paint finish can occur.

Always obey the local regulations regarding the disposal of debris created from cleaning the machine.

Pressure Washing and Steam Cleaning

▲ **CAUTION** When using a steam cleaner, wear safety glasses or a face shield as well as protective clothing. Steam can cause personal injury.

Notice: The battery and other electrical components could be damaged by high pressure washing systems. Special precautions must be taken if the machine is to be washed using a high pressure system.

During pressure jet wash keep all the covers (canopy, chassis access cover etc.) installed.

Keep ignition switch and isolator in off position.

Do not directly pressure wash the electrical components. Use a low pressure washer and brush to remove dried mud or dirt.

Use a steam cleaner to remove soft dirt and oil.

When cleaning around decals:

- Ensure the water pressure is kept below 138bar (2000psi).
- Keep water temperature below 80C (176F).
- Use a spray nozzle with a 40° wide angle spray pattern.
- Keep the nozzle at least 300mm away from and perpendicular (at 90° degrees) to the decal.

The machine must always be greased (if appropriate) after pressure washing or steam cleaning.

Storage

General

If the machine will not be used for an extended period, you must store the machine correctly. If you prepare the machine carefully and apply on-going care you can prevent deterioration and damage to the machine while it is in storage.

Storage Area

The machine can be stored in a temperature range of: -40°C (-39.9°F) to 54°C (129.1°F)

When possible, you must keep the machine in a dry building or shelter.

If only an outdoor storage area is available, look for a storage area with good drainage.

Prepare the Machine for Storage

1. Clean the machine to remove all unwanted material and corrosive products.
2. Dry the machine to remove solvents and moisture.
3. Touch-up any damaged paint.
4. Apply grease to the moving parts (if applicable).
5. Examine the machine for worn or damaged parts. Replace if necessary.
6. Fill the fuel tank to prevent a build up of condensation in the tank (if applicable).
7. Examine the coolant condition. Replace if necessary.
8. Examine all fluid levels. Top up if necessary.

Put into Storage

Make sure that the battery is fully charged or at least above 50%.

1. Park the machine on solid, level ground.
 - 1.1. Park the machine in an area where it is easy to access. (In case the machine does not start at the end of the storage period).
 - 1.2. Put suitable timbers under the machine to eliminate direct contact with the ground.
2. Retract all of the rams and fully lower the boom.
3. Vent the hydraulic system.
4. Remove the ignition key.
5. Apply a thin layer of grease or petroleum jelly to all of the exposed ram piston rods.
6. Remove all the batteries.

[Refer to: Battery \(Page 131\).](#)

 - 6.1. Keep all the batteries in warm, dry conditions.
 - 6.2. Charge all the batteries periodically.
7. If you store the machine outside in cold climate and possible snowfall. Cover the platform control with console cover.

During Storage

Operate the machine functions each week to prevent a build up of rust in the machine and hydraulic circuits, and to minimise the deterioration of the hydraulic seals.

Check the charge level of the batteries every 30 days. Charge the batteries if the charge level is below 50%.
[Refer to: Check \(State of Charge\) \(Page 134\).](#)

1. Remove the grease or petroleum jelly from the ram piston rods.
2. Check the hydraulic oil level. If necessary, add more oil.
3. Start the motor.
4. Operate the hydraulic controls. Make sure that the hydraulic functions operate correctly.
5. Prepare the machine for storage.

Take out of Storage

1. Clean the machine to remove all unwanted material and corrosive products. Dry the machine to remove solvents and moisture.
2. Remove the grease or petroleum jelly from the ram piston rods.
3. Check the hydraulic oil level. If necessary, add more oil.
4. Make sure that the batteries are fully charged.
5. Start the motor.
6. Operate the hydraulic controls. Make sure that the hydraulic functions operate correctly.

Maintenance Introduction

General

Your machine has been designed and built to give maximum performance, economy and ease of use under a wide variety of operating conditions. Prior to delivery, your machine was inspected both at the factory and by your dealer to make sure that it reaches you in optimum condition. To maintain this condition and trouble free operation it is important that the routine services and maintenance, as specified in this manual, are done at the recommended specified intervals and it is recommended that this is done by an approved JCB dealer using genuine JCB parts. Servicing/repairs carried out by unauthorised personnel or the use of non-genuine inferior quality parts could limit machine warranty.

After completing any routine servicing, maintenance or repairs you must complete the functional checks according to the maintenance schedule.

This section of the manual gives full details of the service requirements necessary to maintain your JCB machine at peak efficiency.

Use of electrically insulated tools with PPE's is mandatory to avoid short circuit and electrocution.

It can be seen from the service schedules on the following pages that many essential service checks must only be done by a JCB trained specialist competent person. JCB dealer service engineers have been trained by JCB to do such specialist tasks, and are equipped with the necessary special tools and test equipment to do such tasks, thoroughly, safely, accurately and efficiently.

JCB regularly updates its dealers to advise them of any machine developments, changes in specifications and procedures. Therefore only a JCB dealer is fully able to safely service the machine to the latest requirements, which makes them best placed to maintain and service your machine.

A service record sheet or book is provided at the back of this publication which will enable you to plan your service requirements and keep a service history record. It must be dated, signed and stamped by your dealer each time your machine is serviced.

Remember, if your machine has been correctly maintained, not only will it give you improved reliability but its resale value will be greatly enhanced.

When the machine is removed from service, local regulations for machine decommissioning and disposal will vary. Contact your nearest JCB dealer for further information.

Owner/Operator Support

JCB together with your dealer wants you to be completely satisfied with your new JCB machine. However, if you do have a problem, you can contact your dealer's service department who are there to help you!

You will have been given the names of the relevant service contacts at your dealer when the machine was supplied.

To get the most from your dealer please help them to satisfy you by providing them with:

1. Your name, address and telephone number.
2. Your machine model and serial number.
3. The date of purchase and hours of work.
4. The nature of the problem.

Remember, only your JCB dealer has access to the vast resources available at JCB to help support you. In addition, your dealer is able to offer a variety of programmes covering warranty, fixed price servicing, safety inspections, including weight tests, covering both legal and insurance requirements.

It is machine owner's responsibility to ensure that the maintenance is carried out properly in accordance with the requirement of this manual.

Service/Maintenance Agreements

To help plan and spread the costs of maintaining your machine, we strongly recommend you take advantage of the many service and maintenance agreements your dealer can offer. These can be tailor made to meet your operating conditions, work schedule etc.

Please consult your JCB dealer for details.

Obtaining Spare Parts

If you use non-genuine JCB parts or consumables, then you can compromise the health and safety of the operator and cause machine failure.

A parts book for your machine is available from your JCB dealer. The parts book will help you identify parts and order them from your JCB dealer.

Your dealer will need to know the exact model, build and serial number of your machine.

[Refer to: Product and Component Identification \(Page 8\).](#)

Maintenance Safety

General

Raised Machine

Never position yourself or any part of your body under a raised machine which is not correctly supported. If the machine moves unexpectedly you could become trapped and suffer serious injury or be killed.

Compressed Air

Compressed air is dangerous. Wear personal protective equipment. Never point a compressed air jet at yourself or others.

Springs

Always wear personal protective equipment when dismantling assemblies containing components under pressure from springs. This will protect against eye injury from components accidentally flying out.

Metal Splinters

You can be injured by flying metal splinters when driving metal pins in or out. Use a soft faced hammer or copper drift to remove and install metal pins. Always wear personal protective equipment.

Repairs

If your machine does not function correctly in any way, get it repaired straight away. Neglect of necessary repairs could result in an accident or affect your health. Do not try to do repairs or any other type of maintenance work you do not understand. To avoid injury and/or damage get the work done by a specialist engineer.

Hydraulic Pressure

Hydraulic fluid at system pressure can injure you. Before connecting or removing any hydraulic hose, residual hydraulic pressure trapped in the service hose line must be vented. Make sure the hose service line has been vented before connecting or removing hoses. Make sure the engine cannot be started while the hoses are open.

'O' rings, Seals and Gaskets

Badly installed, damaged or rotted 'O' rings, seals and gaskets can cause leakages and possible accidents. Renew whenever disturbed unless otherwise instructed. Do not use Trichloroethane or paint thinners near 'O' rings and seals.

Counterweights

Your machine may be installed with counterweights. They are extremely heavy. Do not attempt to remove them.

Soft Ground

A machine can sink into soft ground, never work under or on a machine parked on soft ground.

Working Under the Machine

Make the machine safe. Make sure the park brake is engaged and machine is fully isolated. Remove the machine key switch, disconnect the battery. Use blocks to prevent unintentional movement of the wheels.

Lifting the Machine

Under no circumstances must the engine be run with the transmission in gear and only one driving wheel jacked clear of the ground, since the wheel on the ground will move the machine.

Chemicals

Certain seals and gaskets (e.g. crankshaft oil seal) on JCB machines contain fluoroelastomeric materials such as Viton®, Fluorel™ and Technoflon®. Fluoroelastomeric materials subjected to high temperatures can produce highly corrosive hydrofluoric acid. This acid can severely burn. New fluoroelastomeric components at ambient temperature require no special safety precautions. Used fluoroelastomeric components whose temperatures have not exceeded 300°C (572 °F) require no special safety precautions. If evidence of decomposition (e.g. charring) is found, refer to the next paragraph for safety instructions. Do not touch component or surrounding area. Used fluoroelastomeric components subjected to temperatures greater than 300°C (572 °F) (e.g. engine fire) must be treated using the following safety procedure. Make sure that heavy duty gloves and special safety glasses are worn: Thoroughly wash contaminated area with 10% calcium hydroxide or other suitable alkali solution, if necessary use wire wool to remove burnt remains. Thoroughly wash contaminated area with detergent and water. Contain all removed material, gloves etc. used in this operation in sealed plastic bags and dispose of in accordance with Local Authority Regulations. Do not burn fluoroelastomeric materials.

Hydraulic Hoses

Never re-use hydraulic hose end crimps or use reusable hose end crimps.

Personal Protective Equipment

Use the appropriate personal protective equipment before performing maintenance on the machine, otherwise you could be injured.

Working at Height

Use appropriate access equipment such as ladders or a working platform if it is necessary to work at height to perform maintenance tasks on the machine. If you do not use suitable access equipment there is a risk of falling, resulting in personal injury or death.

Fluids and Lubricants

Oil

Oil is toxic. If you swallow any oil, do not induce vomiting, seek medical advice. Used engine oil contains harmful contaminants which can cause skin cancer. Do not handle used engine oil more than necessary. Always use barrier cream or wear gloves to prevent skin contact. Wash skin contaminated with oil thoroughly in warm soapy water. Do not use petrol, diesel fuel or paraffin to clean your skin.

Fluid Under Pressure

Fine jets of fluid at high pressure can penetrate the skin. Keep face and hands well clear of fluid under pressure and wear personal protective equipment. Hold a piece of cardboard close to suspected leaks and then examine the cardboard for signs of fluid. If fluid penetrates your skin, get medical help immediately.

Fuel

Fuel is flammable, keep naked flames away from the fuel system. Stop the engine immediately if a fuel leak is suspected. Do not smoke while refuelling or working on the fuel system. Do not refuel with the engine running. Completely wipe off any spilt fuel which could cause a fire. There could be a fire and injury if you do not follow these precautions.

Hygiene

JCB lubricants are not a health risk when used correctly for their intended purposes.

However, excessive or prolonged skin contact can remove the natural fats from your skin, causing dryness and irritation.

Low viscosity oils are more likely to do this, so take special care when handling used oils, which might be diluted with fuel contamination.

Whenever you are handling oil products you must maintain good standards of care and personal and plant hygiene. For details of these precautions we advise you to read the relevant publications issued by your local health authority, plus the following.

Storage

Always keep lubricants out of the reach of children.

Never store lubricants in open or unlabelled containers.

Waste Disposal

▲ CAUTION It is illegal to pollute drains, sewers or the ground. Clean up all spilt fluids and/or lubricants.

Used fluids and/or lubricants, filters and contaminated materials must be disposed of in accordance with local regulations. Use authorised waste disposal sites.

CAUTION Damaged or spent batteries and any residue from fires or spillage must be put in a suitable closed receptacle and must be disposed of in accordance with local environmental waste regulations.

All waste products must be disposed of in accordance with all the relevant regulations.

The collection and disposal of used oil must be in accordance with any local regulations. Never pour used engine oil into sewers, drains or on the ground.

Handling

▲ CAUTION The temperature of the hydraulic oil will be high soon after stopping the machine. Wait until it cools before beginning maintenance.

New Oil

There are no special precautions needed for the handling or use of new oil, beside the normal care and hygiene practices.

Used Oil

Used engine crankcase lubricants contain harmful contaminants.

Here are precautions to protect your health when handling used engine oil:

- Wear gloves
- Avoid prolonged, excessive or repeated skin contact with used oil
- Apply a barrier cream to the skin before handling used oil. Note the following when removing engine oil from skin:
 - Wash your skin thoroughly with soap and water
 - Using a nail brush will help
 - Use special hand cleansers to help clean dirty hands
 - Never use petrol, diesel fuel, or paraffin for washing
- Avoid skin contact with oil soaked clothing
- Don't keep oily rags in pockets
- Wash dirty clothing before re-use
- Throw away oil-soaked shoes

Battery

Warning Symbols

▲ DANGER Batteries give off an explosive gas. Do not smoke when handling or working on the battery. Keep the battery away from sparks and flames.

Battery electrolyte contains sulphuric acid. It can burn you if it touches your skin or eyes. Wear goggles. Handle the battery carefully to prevent spillage. Keep metallic items (watches, rings, zips etc) away from the battery terminals. Such items could short the terminals and burn you.

Set all switches to off before disconnecting and connecting the battery. When disconnecting the battery, take off the earth (-) lead first.

Re-charge the battery away from the machine, in a well ventilated area. Switch the charging circuit off before connecting or disconnecting the battery. When you have installed the battery in the machine, wait 5min before connecting it up.

When reconnecting, attach the positive (+) lead first.

Notice: Do not disconnect the battery while the engine is running, otherwise the electrical circuits may be damaged.

CAUTION Understand the electrical circuit before connecting or disconnecting an electrical component. A wrong connection can cause injury and/or damage.

WARNING Battery electrolyte is toxic and corrosive. Do not breathe the gases given off by the battery. Keep the electrolyte away from your clothes, skin, mouth and eyes. Wear safety glasses.

CAUTION Damaged or spent batteries and any residue from fires or spillage must be put in a suitable closed receptacle and must be disposed of in accordance with local environmental waste regulations.

DANGER Batteries give off explosive gases. Keep flames and sparks away from the battery. Do not smoke close to the battery. Make sure there is good ventilation in closed areas where batteries are being used

or charged. Do not check the battery charge by shorting the terminals with metal. Use a hydrometer or voltmeter.

The following warning symbols may be found on the battery.

Figure 55.

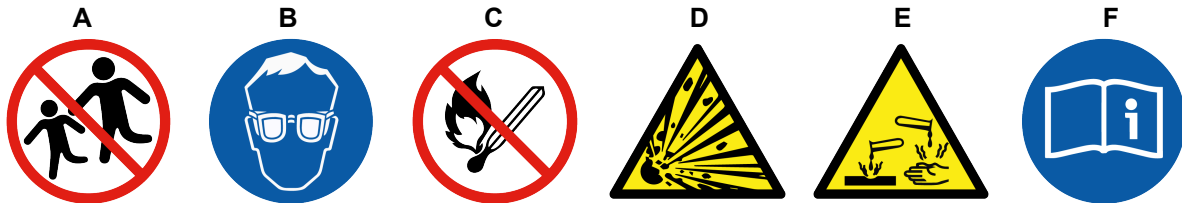

- | | |
|---|---|
| <p>A Keep away from children
 C No smoking, no naked flames, no sparks
 E Battery acid</p> | <p>B Shield eyes
 D Explosive gas
 F Note operating instructions</p> |
|---|---|

First Aid - Oil

Eyes

In the case of eye contact, flush with water for 15min. If irritation persists, get medical attention.

Swallowing

If oil is swallowed do not induce vomiting. Get medical advice.

Skin

In the case of excessive skin contact, wash with soap and water.

Spillage

Absorb with sand or a locally approved brand of absorbent granules. Scrape up and remove to a chemical disposal area.

Fires

▲ WARNING Do not use water to put out an oil fire. This will only spread it because oil floats on water.
 Extinguish oil and lubricant fires with carbon dioxide, dry chemical or foam.

First Aid - Electrolyte

Eyes

In the case of eye contact, flush with water for 15min. always get medical attention.

Swallowing

Do not induce vomiting. Drink large quantities of water or milk. Then drink milk of magnesia, beaten egg or vegetable oil. Get medical help.

Skin

Flush with water, remove affected clothing. Cover burns with a sterile dressing then get medical help.

Maintenance Schedules

General

▲ WARNING Maintenance must be done only by suitably qualified and competent persons.

Before doing any maintenance make sure the machine is safe, it must be correctly parked on solid, level ground.

To prevent anyone starting the machine, remove the key. Disconnect the battery (by means of the battery isolator if installed) when you are not using electrical power. If you do not take these precautions you could be killed or injured.

A badly maintained machine is a danger to the operator and the people working around the operator. Make sure that the regular maintenance and lubrication tasks listed in the service schedules are done to keep the machine in a safe and efficient working condition.

Apart from the daily tasks, the schedules are based on time. Keep a regular check on the hourmeter readings to monitor the hourmeter equivalents. When there is no hourmeter installed, use the calendar equivalents to determine the service intervals.

Do not use a machine which is due for a service. Make sure any defects found during the regular maintenance checks are corrected immediately.

How to Use the Maintenance Schedules

The schedules show the service tasks which must be done and their intervals.

The services must be done at either the hourly interval or the calendar equivalent, whichever occurs first.

The intervals given in the schedules must not be exceeded. If the machine is operated under severe conditions (high temperature, dust, water, etc.) shorten the intervals. Where local regulations require more frequent checks, the local regulations intervals should be followed.

Table 12.

○	Service task can be completed by a competent operator. Details of how to complete the service task are given in the Operator's Manual.
□	We recommend that a Service Engineer completes the service task. Details of how to complete the service task are given in the Service Manual.

Maintenance Intervals

Table 13.

Interval (h)	Calendar Equivalent
6	Daily
20	Weekly
150	Six months
250	Yearly
500	Two years
1250	Five years

Operator Maintenance Tasks

Table 14.

Component	Task	Daily	Weekly	150
Hydraulics				
Hydraulic hoses	Check (condition)	○	○	○
Hydraulic oil	Check (level)	○	○	○
Hydraulic oil	Check (leaks)	○	○	○



Component	Task	Daily	Weekly	150
Engine				
Engine oil	Check (level)	○	○	○
Engine oil	Check (leaks)	○	○	○
Engine coolant	Check (level)	○	○	○
Engine coolant	Check (leaks)	○	○	○
Engine radiator	Check (condition)			○
Cooling pack	Check / Clean	○	○	○
Front end drive belt	Check (condition)		○	○
Air filter	Check (condition)	○	○	○
Air filter dust valve	Check operation / Clean		○	○
Engine fuel	Check (leaks)	○	○	○
Water separator / fuel filter	Clean / Drain	○	○	○
Fuel tank cap-vent	Check (condition)	○	○	○
Exhaust system	Check (condition)	○	○	○
Electrics				
Battery	Clean	○	○	○
Battery charge	Check	○	○	○
Battery electrolyte level (if applicable)	Check (level)	○	○	○
Battery isolator	Check (operation)	○	○	○
Battery terminal	Clean	○	○	○
Battery leads	Check (condition)	○	○	○
All electrical cables and conductors	Check (condition)	○	○	○
Wiring	Check (condition)		○	○
RCBO (Residual Current Breaker with Over-Current)	Check (operation)			○
AC (Alternating Current) power to platform cables	Visual inspection			○
AC power to platform cables	Check (operation)			○
Miscellaneous				
Safety labels - renew as required	Check (condition)	○	○	○
Operator's Manual	Check (condition)	○	○	○
Canopy and latches	Check (condition)	○	○	○
Welds	Check (condition)	○	○	○
Fasteners	Check (condition)	○	○	○
Platform guard rail	Check (condition)	○	○	○
Telescopic boom (inner and outer)	Grease (waxoyl)			○
Steering linkages	Check (condition)			○
Limited driving speed (with platform lifted and stowed)	Check (operation)	○	○	○
Tilt sensor	Check (operation)	○	○	○
Limit switch and boom position indicator	Check (operation)	○	○	○

Component	Task	Daily	Weekly	150
Axle oscillation lock	Check (operation)	○	○	○
Platform levelling	Check (operation)	○	○	○
Travel alarm	Check (operation)	○	○	○
Buzzers	Check (operation)	○	○	○
Platform secondary guarding system	Check (operation)	○	○	○
Slew acknowledgment functions	Check (operation)	○	○	○
Tyres and wheels	Check (condition)	○	○	○
Machine damage, missing parts	Check (condition)	○	○	○
Wheel lug nuts	Check (torque)		○	○
Base controller				
Emergency stop	Check (operation)	○	○	○
Platform raise and lower functions	Check (operation)	○	○	○
Electric pump	Check (operation)	○	○	○
Ignition switch	Check (operation)	○	○	○
Base control emergency override	Check (operation)	○	○	○
Horn	Check (operation)	○	○	○
Emergency override switch	Check (operation)	○	○	○
Platform controller				
Emergency stop	Check (operation)	○	○	○
Platform raise and lower functions	Check (operation)	○	○	○
Foot pedal switch	Check (operation)	○	○	○
Steering	Check (operation)	○	○	○
Drive and brake	Check (operation)	○	○	○
Worklight (if installed)	Check (operation)	○	○	○
Power to platform (if power tool installed)	Check (operation)	○	○	○
Horn	Check (operation)	○	○	○

(1) Check the charge level of the batteries at least every 30 days. Charge the batteries if the charge level is below 50%.

Service Engineer Maintenance Tasks

Table 15.

Component	Task	250h	500h	1000h
Hydraulics				
Hydraulic hoses	Check (condition)	□	□	□
Hydraulic oil	Check (level)	□	□	□
Hydraulic oil	Check (leaks)	□	□	□
Hydraulic oil	Replace		□	□
Hydraulic return filter	Replace		□	□
Suction strainer	Replace		□	□
Charge pump filter	Replace		□	□



Component	Task	250h	500h	1000h
High pressure filter	Replace		<input type="checkbox"/>	<input type="checkbox"/>
Vent filter - hydraulic tank	Replace		<input type="checkbox"/>	<input type="checkbox"/>
Engine				
Engine compartment	Check (security)	<input type="checkbox"/>	<input type="checkbox"/>	<input type="checkbox"/>
Engine compartment hose	Check (condition / security)	<input type="checkbox"/>	<input type="checkbox"/>	<input type="checkbox"/>
Engine oil	Check (level)	<input type="checkbox"/>	<input type="checkbox"/>	<input type="checkbox"/>
Engine oil	Check (leaks)	<input type="checkbox"/>	<input type="checkbox"/>	<input type="checkbox"/>
Engine oil	Replace	<input type="checkbox"/>	<input type="checkbox"/>	<input type="checkbox"/>
Engine oil filter	Replace	<input type="checkbox"/>	<input type="checkbox"/>	<input type="checkbox"/>
Engine coolant	Check (level)	<input type="checkbox"/>	<input type="checkbox"/>	<input type="checkbox"/>
Engine coolant	Check (condition)	<input type="checkbox"/>	<input type="checkbox"/>	<input type="checkbox"/>
Engine coolant	Replace		<input type="checkbox"/>	<input type="checkbox"/>
Engine coolant	Check (leaks)	<input type="checkbox"/>	<input type="checkbox"/>	<input type="checkbox"/>
Engine radiator	Check (condition)	<input type="checkbox"/>	<input type="checkbox"/>	<input type="checkbox"/>
Cooling pack	Check / Clean	<input type="checkbox"/>	<input type="checkbox"/>	<input type="checkbox"/>
Front end drive belt	Check (condition)	<input type="checkbox"/>	<input type="checkbox"/>	<input type="checkbox"/>
Air filter	Check (condition)	<input type="checkbox"/>	<input type="checkbox"/>	<input type="checkbox"/>
Air filter element (outer)	Replace	<input type="checkbox"/>	<input type="checkbox"/>	<input type="checkbox"/>
Air filter element (inner)	Replace		<input type="checkbox"/>	<input type="checkbox"/>
Air filter dust valve	Check operation / Clean	<input type="checkbox"/>	<input type="checkbox"/>	<input type="checkbox"/>
Engine fuel	Check (leaks)	<input type="checkbox"/>	<input type="checkbox"/>	<input type="checkbox"/>
Water separator / fuel filter	Clean / Drain	<input type="checkbox"/>	<input type="checkbox"/>	<input type="checkbox"/>
Water separator / fuel filter	Replace	<input type="checkbox"/>	<input type="checkbox"/>	<input type="checkbox"/>
Engine fuel filter	Replace	<input type="checkbox"/>	<input type="checkbox"/>	<input type="checkbox"/>
Fuel tank cap-vent	Check (condition)	<input type="checkbox"/>	<input type="checkbox"/>	<input type="checkbox"/>
Exhaust system	Check (condition)	<input type="checkbox"/>	<input type="checkbox"/>	<input type="checkbox"/>
Electrics				
Battery	Clean	<input type="checkbox"/>	<input type="checkbox"/>	<input type="checkbox"/>
Battery charge	Check	<input type="checkbox"/>	<input type="checkbox"/>	<input type="checkbox"/>
Battery electrolyte level (if applicable)	Check (level)	<input type="checkbox"/>	<input type="checkbox"/>	<input type="checkbox"/>
Battery isolator	Check (operation)	<input type="checkbox"/>	<input type="checkbox"/>	<input type="checkbox"/>
Battery terminal	Clean	<input type="checkbox"/>	<input type="checkbox"/>	<input type="checkbox"/>
Battery leads	Check (condition)	<input type="checkbox"/>	<input type="checkbox"/>	<input type="checkbox"/>
All electrical cables and conductors	Check (condition)	<input type="checkbox"/>	<input type="checkbox"/>	<input type="checkbox"/>
Wiring	Check (condition)	<input type="checkbox"/>	<input type="checkbox"/>	<input type="checkbox"/>
RCBO (Residual Current Breaker with Over-Current)	Check (operation)	<input type="checkbox"/>	<input type="checkbox"/>	<input type="checkbox"/>
AC (Alternating Current) power to platform cables	Visual inspection	<input type="checkbox"/>	<input type="checkbox"/>	<input type="checkbox"/>



Component	Task	250h	500h	1000h
AC power to platform cables	Check (operation)	<input type="checkbox"/>	<input type="checkbox"/>	<input type="checkbox"/>
Miscellaneous				
Safety labels - renew as required	Check (condition)	<input type="checkbox"/>	<input type="checkbox"/>	<input type="checkbox"/>
Operator's Manual	Check (condition)	<input type="checkbox"/>	<input type="checkbox"/>	<input type="checkbox"/>
Canopy and latches	Check (condition)	<input type="checkbox"/>	<input type="checkbox"/>	<input type="checkbox"/>
Welds	Check (condition)	<input type="checkbox"/>	<input type="checkbox"/>	<input type="checkbox"/>
Fasteners	Check (condition)	<input type="checkbox"/>	<input type="checkbox"/>	<input type="checkbox"/>
Platform guard rail	Check (condition)	<input type="checkbox"/>	<input type="checkbox"/>	<input type="checkbox"/>
Steer pivots	Grease	<input type="checkbox"/>	<input type="checkbox"/>	<input type="checkbox"/>
Hub oil	Check (level)	<input type="checkbox"/>	<input type="checkbox"/>	<input type="checkbox"/>
Hub oil ⁽²⁾	Replace			<input type="checkbox"/>
Telescopic boom wear pad	Check (condition)		<input type="checkbox"/>	<input type="checkbox"/>
Telescopic boom (inner and outer)	Grease (waxoyl)	<input type="checkbox"/>	<input type="checkbox"/>	<input type="checkbox"/>
Slew bearing	Check (condition)		<input type="checkbox"/>	<input type="checkbox"/>
Limited driving speed (with platform lifted and stowed)	Check (operation)	<input type="checkbox"/>	<input type="checkbox"/>	<input type="checkbox"/>
Tilt sensor	Check (operation)	<input type="checkbox"/>	<input type="checkbox"/>	<input type="checkbox"/>
Limit switch and boom position indicator	Check (operation)	<input type="checkbox"/>	<input type="checkbox"/>	<input type="checkbox"/>
Axle oscillation lock	Check (operation)	<input type="checkbox"/>	<input type="checkbox"/>	<input type="checkbox"/>
Platform levelling	Check (operation)	<input type="checkbox"/>	<input type="checkbox"/>	<input type="checkbox"/>
Overload system	Check (operation)	<input type="checkbox"/>	<input type="checkbox"/>	<input type="checkbox"/>
Hydraulic system pressure	Check (settings)	<input type="checkbox"/>	<input type="checkbox"/>	<input type="checkbox"/>
Hydraulic system functional test	Check (operation)	<input type="checkbox"/>	<input type="checkbox"/>	<input type="checkbox"/>
Overload test	Check (operation)	<input type="checkbox"/>	<input type="checkbox"/>	<input type="checkbox"/>
Drive speed	Check	<input type="checkbox"/>	<input type="checkbox"/>	<input type="checkbox"/>
Boom and slew speed	Check	<input type="checkbox"/>	<input type="checkbox"/>	<input type="checkbox"/>
Steering linkages	Check (condition)	<input type="checkbox"/>	<input type="checkbox"/>	<input type="checkbox"/>
Travel alarm	Check (operation)	<input type="checkbox"/>	<input type="checkbox"/>	<input type="checkbox"/>
Buzzers	Check (operation)	<input type="checkbox"/>	<input type="checkbox"/>	<input type="checkbox"/>
Platform secondary guarding system	Check (operation)	<input type="checkbox"/>	<input type="checkbox"/>	<input type="checkbox"/>
Slew acknowledgment functions	Check (operation)	<input type="checkbox"/>	<input type="checkbox"/>	<input type="checkbox"/>
Tyres and wheels	Check (condition)	<input type="checkbox"/>	<input type="checkbox"/>	<input type="checkbox"/>
Machine damage, missing parts	Check (condition)	<input type="checkbox"/>	<input type="checkbox"/>	<input type="checkbox"/>
Wheel lug nuts	Check (torque)	<input type="checkbox"/>	<input type="checkbox"/>	<input type="checkbox"/>
Rear axle capscrews - hub to chassis	Check (torque)	<input type="checkbox"/>	<input type="checkbox"/>	<input type="checkbox"/>
Front axle capscrews - hub to knuckle	Check (torque)	<input type="checkbox"/>	<input type="checkbox"/>	<input type="checkbox"/>
Setscrews - platform to carrier underside	Check (torque)	<input type="checkbox"/>	<input type="checkbox"/>	<input type="checkbox"/>
Setscrews - rotary actuator top ring	Check (torque)	<input type="checkbox"/>	<input type="checkbox"/>	<input type="checkbox"/>
Pivot pin with locknut - rotary actuator	Check (torque)	<input type="checkbox"/>	<input type="checkbox"/>	<input type="checkbox"/>



Component	Task	250h	500h	1000h
Slew bearing bolts (top and bottom sets)	Check (torque)	<input type="checkbox"/>	<input type="checkbox"/>	<input type="checkbox"/>
Counterweight bolts	Check (torque)	<input type="checkbox"/>	<input type="checkbox"/>	<input type="checkbox"/>
Base controller				
Emergency stop	Check (operation)	<input type="checkbox"/>	<input type="checkbox"/>	<input type="checkbox"/>
Platform raise and lower functions	Check (operation)	<input type="checkbox"/>	<input type="checkbox"/>	<input type="checkbox"/>
Electric pump	Check (operation)	<input type="checkbox"/>	<input type="checkbox"/>	<input type="checkbox"/>
Ignition switch	Check (operation)	<input type="checkbox"/>	<input type="checkbox"/>	<input type="checkbox"/>
Base control emergency override	Check (operation)	<input type="checkbox"/>	<input type="checkbox"/>	<input type="checkbox"/>
Horn	Check (operation)	<input type="checkbox"/>	<input type="checkbox"/>	<input type="checkbox"/>
Emergency override switch	Check (operation)	<input type="checkbox"/>	<input type="checkbox"/>	<input type="checkbox"/>
Platform controller				
Emergency stop	Check (operation)	<input type="checkbox"/>	<input type="checkbox"/>	<input type="checkbox"/>
Platform raise and lower functions	Check (operation)	<input type="checkbox"/>	<input type="checkbox"/>	<input type="checkbox"/>
Foot pedal switch	Check (operation)	<input type="checkbox"/>	<input type="checkbox"/>	<input type="checkbox"/>
Steering	Check (operation)	<input type="checkbox"/>	<input type="checkbox"/>	<input type="checkbox"/>
Drive and brake	Check (operation)	<input type="checkbox"/>	<input type="checkbox"/>	<input type="checkbox"/>
Worklight (if installed)	Check (operation)	<input type="checkbox"/>	<input type="checkbox"/>	<input type="checkbox"/>
Power to platform (if power tool installed)	Check (operation)	<input type="checkbox"/>	<input type="checkbox"/>	<input type="checkbox"/>
Horn	Check (operation)	<input type="checkbox"/>	<input type="checkbox"/>	<input type="checkbox"/>

(1) Check the charge level of the batteries at least every 30 days. Charge the batteries if the charge level is below 50%.

(2) An initial hub oil replacement should be made after the first 50 hours of operations. Subsequent oil changes should be made at 1000 hours or annually, which ever comes first.

Maintenance Positions

General

Make the machine safe before you start the maintenance procedure.

1. Park the machine on firm, level ground.
2. Make sure that machine is in stowed position.
3. Set engine to OFF position and remove the ignition key from ignition switch.
4. Disconnect the battery to prevent accidental operation.
5. Put chocks at front and rear of all wheels.

Figure 56. Platform Lowered Position

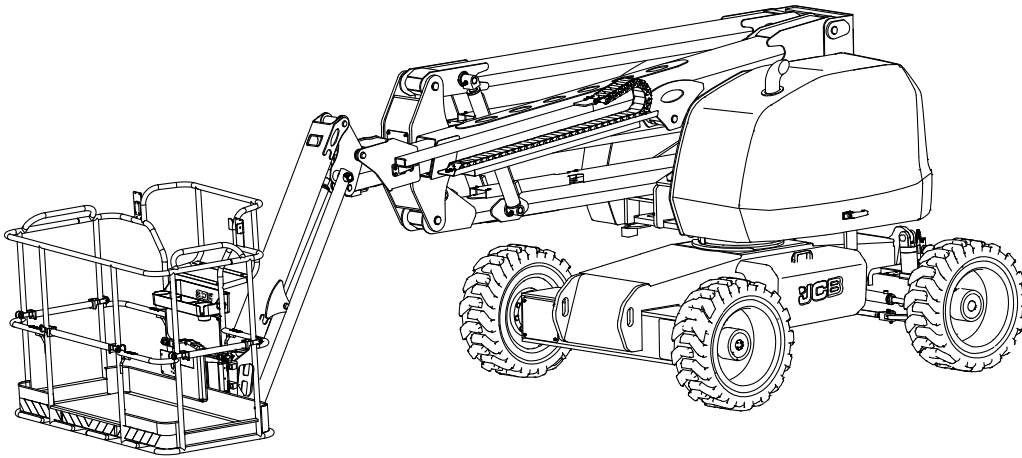

Service Points

General

Figure 57.

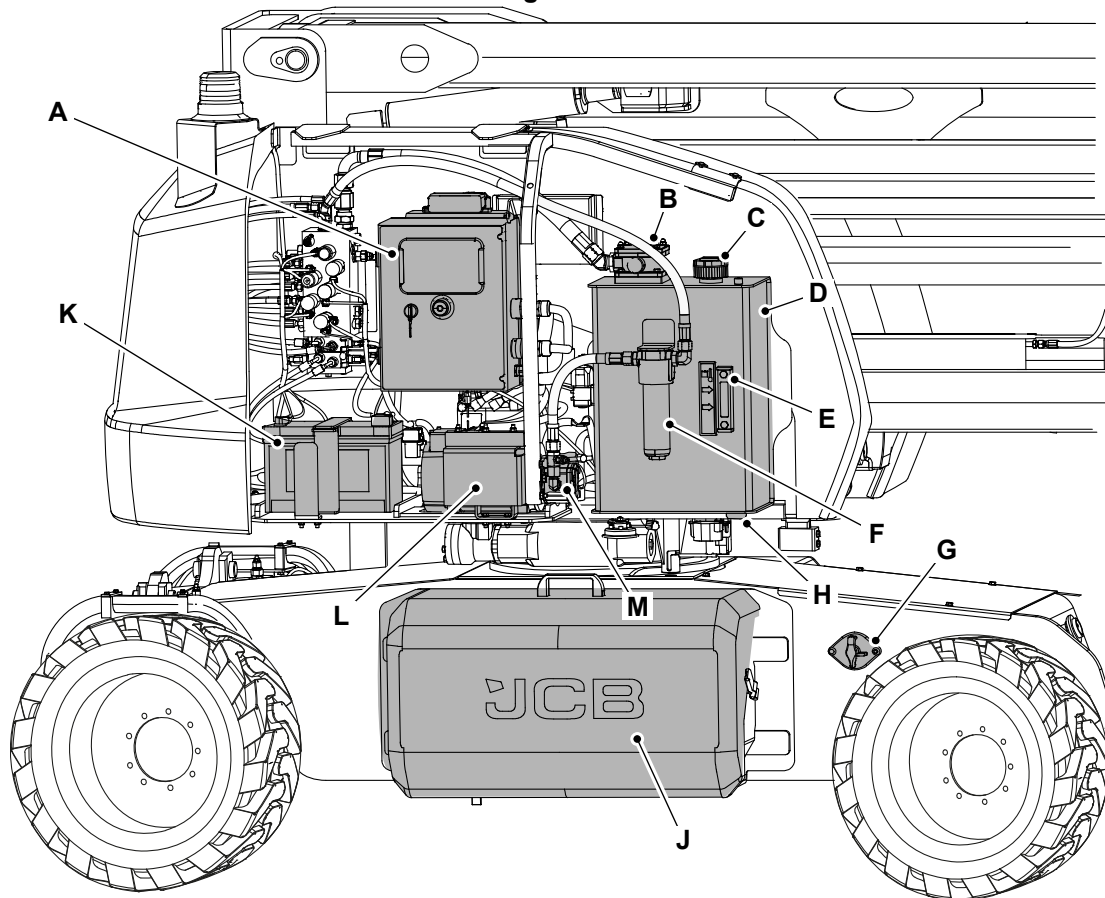

- | | |
|--|---|
| A Base control panel | B Return line filter |
| C Filler breather | D Hydraulic tank |
| E Level gauge / oil temperature | F Hydraulic high pressure filter |
| G Battery isolator | H Hydraulic tank drain plug |
| J Powerpack | K 12V battery |
| L Hydraulic pump motor | M Hydraulic pump |

Figure 58.

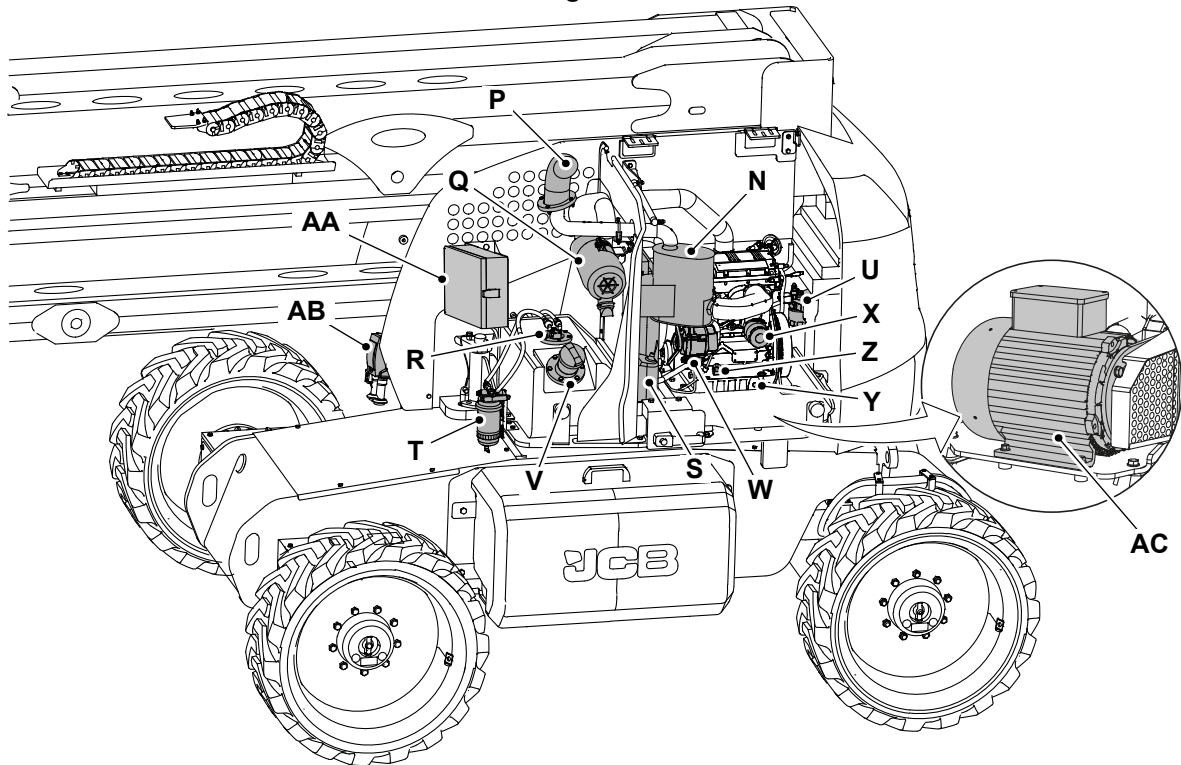

- | | |
|-----------------------------|---|
| N Engine exhaust | P Exhaust outlet pipe |
| Q Air cleaner | R Fuel tank |
| S Radiator | T Pre filter |
| U Engine fuel filter | V Fuel tank filler |
| W Alternator | X Oil filter |
| Y Oil dipstick | Z Oil drainage plug |
| AA Change over box | AB RCBO (Residual Current Breaker with Over-Current) enclosure |
| AC Generator | |

Access Apertures

General

When moved to their maintenance position, the access panels give you access to parts or areas of the machine that are not required during machine operation.

Before you operate the machine, make sure that all of the access panels are correctly in their closed or installed positions.

Battery Cover

Open

Access to the battery compartment is provided by opening the battery cover.

1. Make the machine safe.
2. Release the latches on the both side of the battery cover.
3. Carefully lift the battery cover.
4. Remove the battery cover away from the machine.

Figure 59.

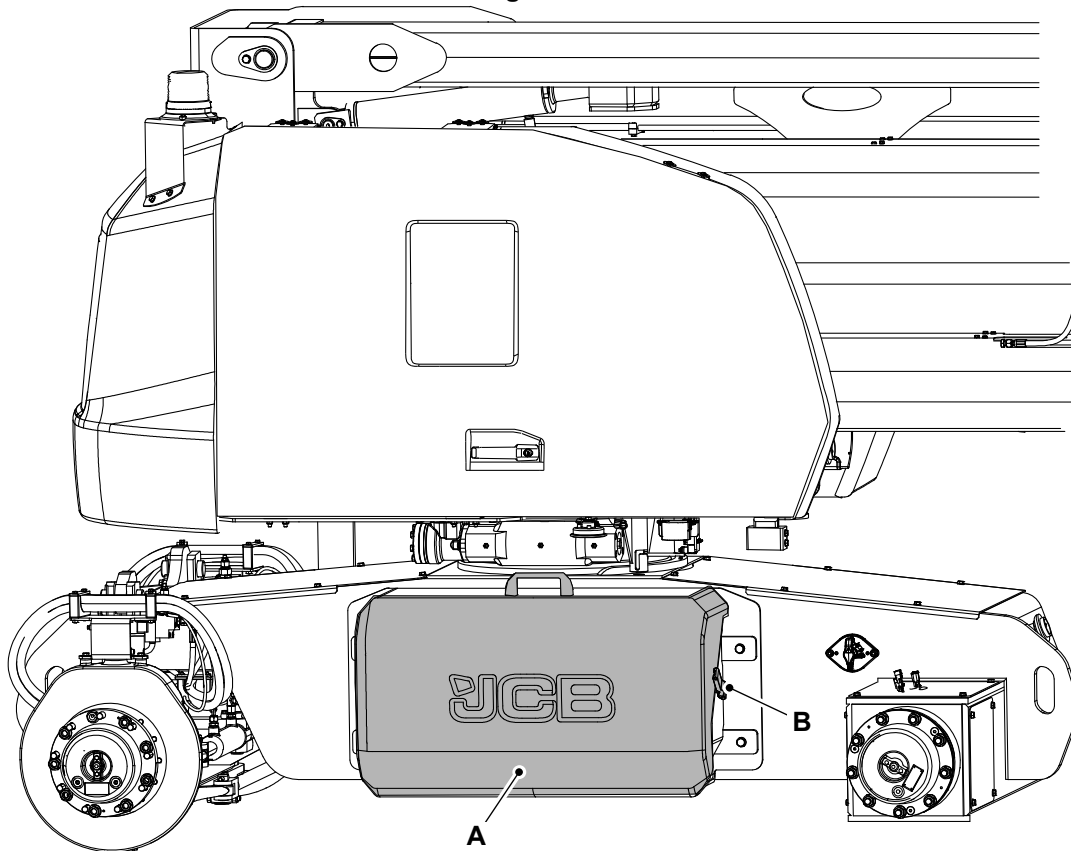

A Battery cover

B Latch

Close

1. Install the battery cover.
2. Make sure the battery cover is correctly latched.

Engine Compartment Cover

To open the cover:

1. Unlock the right hand side body panel with the ignition key.
2. Push the lock to release the latch.
3. Pull the handle to open the cover.
4. Open cover is supported by gas springs.

Figure 60.

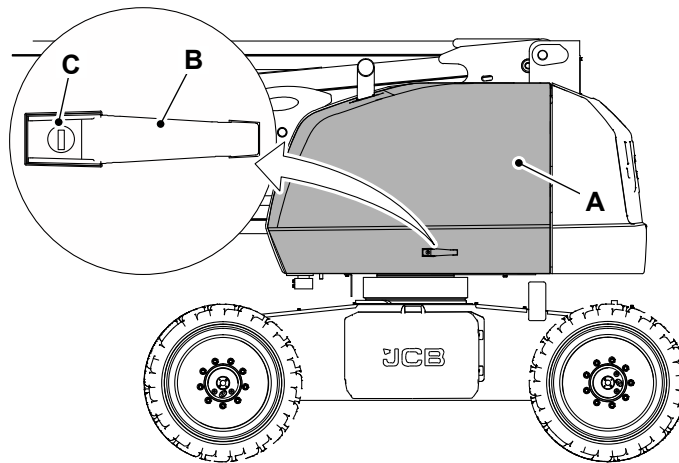

A Engine compartment cover
C Lock

B Handle

To close the cover

1. Close the cover by pushing the handle firmly; it will latch itself.

Engine Access

To open the engine tray:

1. Remove the securing bolt with specified A/F spanner.
Length: 22mm
2. Remove the locking pin from swivel side.
3. Pull the engine tray out with a door stop.
4. Insert the locking pin to keep the engine tray in locked position.

Figure 61.

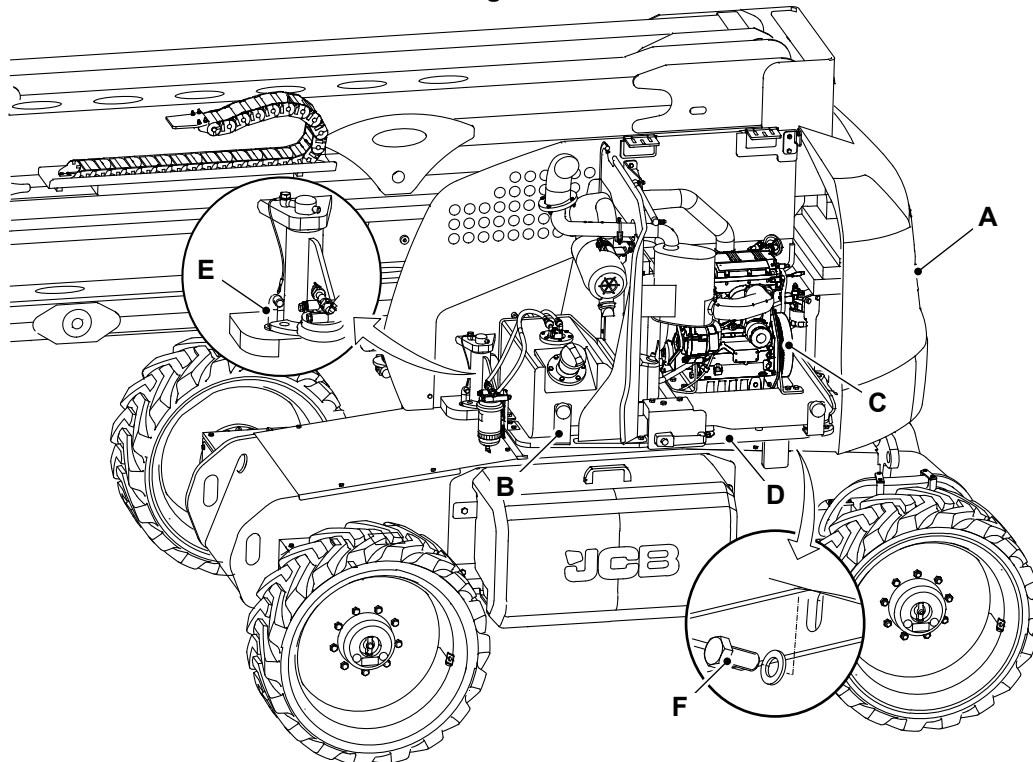

- A Counter weight
- C Engine
- E Locking pin

- B Door stop
- D Engine tray
- F Securing bolt

To close the engine tray:

1. Remove the locking pin and push the tray with door stop.
2. Insert locking pin at swivel side.
3. Install and torque tighten the securing bolt with 22mm A/F spanner.
Torque: 184N·m
4. Close the cover by pushing the handle firmly; it will latch itself.

Hydraulic Compartment Cover

To open the cover:

1. Unlock the cover with the ignition key.
2. Push the lock to release the latch.
3. Pull the handle to open the cover.

Figure 62.

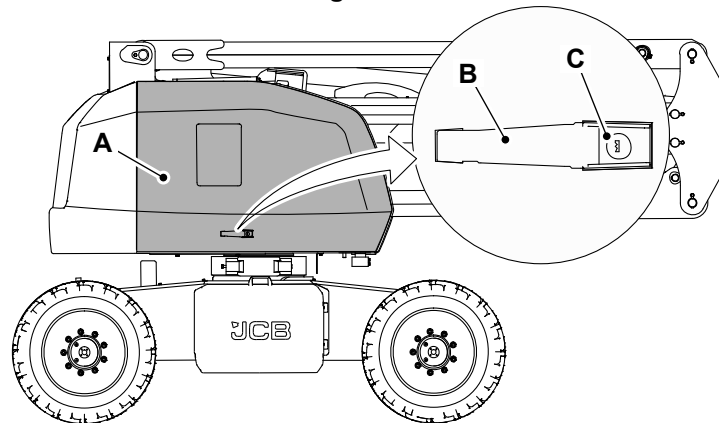

A Body panel left side
C Lock

B Handle

To close the cover:

1. Close the cover by pushing the handle firmly; it will latch itself.

Front Cover

To open the chassis front cover:

1. Make the machine safe.
[Refer to: Maintenance Positions \(Page 91\).](#)
2. Get access to the chassis front cover.
3. Remove setscrew (x6) and washers from the cover.

Figure 63.

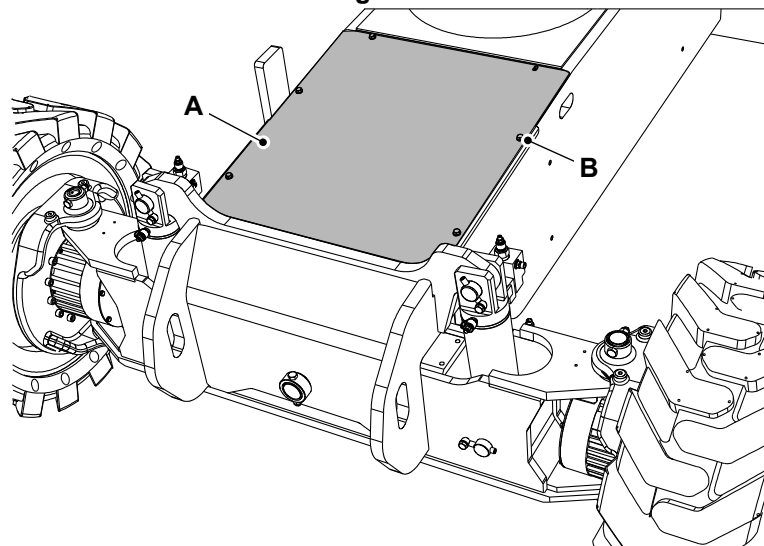

A Front chassis cover

B Setscrew (x6)

4. Remove the cover plate from the machine.

To close the chassis front cover:

1. Install the chassis front cover.

2. Tighten the setscrew to the specified torque value.
Torque: 22N·m

Rear Cover

To open the chassis rear cover:

1. Make the machine safe.
[Refer to: Maintenance Positions \(Page 91\).](#)
2. Get access to the chassis rear cover.
3. Remove setscrews (x6) and washers from the cover.

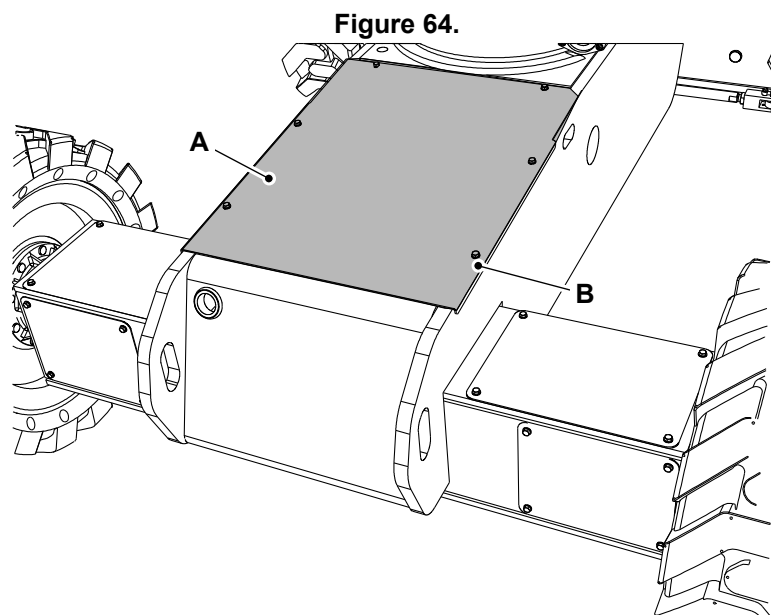

A Rear chassis cover

B Setscrew (x6)

4. Remove the cover plate from the machine.

To close the chassis rear cover:

1. Install the chassis rear cover.
2. Tighten the setscrews to the specified torque value.
Torque: 22N·m

Body and Framework

General

Check (Condition)

1. Make sure that all of the guards and protective devices are in position, secured by their locking devices and free from damage.
2. Inspect all of the steelwork for damage. Include the following:
 - 2.1. Examine all of the pivot point welds.
 - 2.2. Examine the condition of all the pivot pins.
 - 2.3. Check that the pivot pins are correctly in position and secured by their locking devices.
3. Check the guardrails are undamaged.
4. Check that all of the safety and instructional labels are undamaged and in position. Install new labels where necessary.
5. Note any damaged paintwork for future repair.
6. Inspect the machine for broken or loose fasteners.

Controls

Check (Operation)

Functional Check

The functional checks are intended to discover any malfunctions before the machine is put into service. The operator must follow the step-by-step instructions to test all machine functions. A malfunctioning machine must never be used. If malfunctions are discovered, the machine must be tagged and removed from service. Repairs to the machine may only be made by a qualified service technician, according to the manufacturer's specifications

Pre-operation Checks

Functional Checks from Base Control

1. Make the machine safe.
2. Select a test area that is firm, level and free of obstruction.
3. Insert the ignition key and turn the ignition key to the ON position.
 - 3.1. The display switches ON and buzzers at base and platform beep 3 times.
 - 3.2. No alarm information should be displayed on screen.

Horn Button Check

1. Press the horn button from the base and platform control panel, the horn should sound.

Engine Start / Stop Button Check

1. Push the engine start / stop button.
2. Wait for 10 seconds after pressing the engine start / stop button, engine starts cranking after 10 seconds.
3. Make sure that the engine runs smoothly and constantly at 3000 RPM (Revolutions Per Minute), without abnormal sound and black, blue or white smoke from exhaust pipe.

Emergency Stop Button Check

1. Press the emergency stop button at the base control panel.
2. Turn the ignition key, the machine will not start.
 - 2.1. Release the emergency stop button at the base control panel, turn the ignition key and make sure machine starts normally.
3. Press the platform emergency stop button and release the base emergency stop button.
 - 3.1. Turn the ignition key, the machine will not start.

Maximum Pressure Check

To measure the maximum main boom valve pressure:

1. Enable the base control and operate the main boom function to fully open the boom cylinder.
2. Measure the maximum pressure on the base control valve. Make sure it is below 210 bar.

Base Control Function Test

Base Control Enable Switch Check

1. Press and hold the base control enable switch and push the functions button. The machine will function normally.
2. Release the base control enable switch and push the functions button. The machine functions will not be operative.

Check following boom function with base control enable switch pressed down. For machine stowed and raised position.

[Refer to: Instrument Panel \(Page 28\).](#)

Main Boom Function Check

1. Push up the main boom toggle switch. The main boom raises steadily.
 - 1.1. Make sure there is no jitter or abnormal sound.
2. Push down the main boom toggle switch. The main boom is lowers steadily.
 - 2.1. Make sure there is no jitter or abnormal sound.

Articulated Boom Function Check

1. Push up the articulated boom toggle switch. The articulated boom is raises steadily.
 - 1.1. Make sure there is no jitter or abnormal sound.
2. Push down the articulated boom toggle switch. The articulated boom lowers steadily.
 - 2.1. Make sure there is no jitter or abnormal sound.

Telescopic Boom Extend / Retract Check

1. Push the telescopic boom toggle switch to the right. The telescopic boom extends steadily.
 - 1.1. Make sure there is no jitter or abnormal sound.
2. Push the telescopic boom toggle switch to the left. The telescopic boom retracts steadily.
 - 2.1. Make sure there is no jitter or abnormal sound.

Platform Level Function Check

1. Push up platform level toggle switch. The basket and jib moves upwards.
2. Push down platform level toggle switch. The basket and jib moves downwards.

Platform Rotary Actuator Check

1. Press platform rotate toggle switch to the left, the platform rotates clockwise (from plan view).
2. Press platform rotate toggle switch to the right, the platform rotates counter clockwise (from plan view).

Slew Rotation Check

Make sure the slew lock pin is not engaged with turntable and then start test as follows:

1. Push the slew toggle switch to the left, the turntable swings clockwise (from plan view), and the buzzer sounds.
2. Push the slew toggle switch to the right, the turntable swings counter clockwise (from plan view), and the buzzer sounds.

Jib Function Check

1. Push the jib toggle switch up, the jib moves upwards.
2. Push the jib toggle switch down, the jib moves downwards.

Auxiliary Power Function Check

1. Make sure that the ignition key is in the ON position.

- 1.1. When the base control enable switch is operated and the pump motor gives DTC error, base 'AUX' mode will be activated and boom function will operate normally.

Emergency Override Check

1. The base override switch must be pressed during start-up (an ignition cycle with the override button pressed is required) to activate the base override mode.
2. The base override switch must be held down to remain in base override mode.
3. Platform emergency stop and / or overload do not have to be active conditions to activate the override mode.
4. When the override mode is activated, the message 'base override' appears on the display of the base.
5. When the override mode is activated, a beep is heard.
6. When base override mode is activated, only base controls are active, platform controls are ignored.
7. When the base override mode is activated, the movements are only driven by the auxiliary pump (electric).
8. The auxiliary pump (electric) is only activated when a boom function switch is pressed in addition to the base override switch. The selector switch for the base / platform is ignored.
9. When the base override mode is activated, the boom function can be used one at a time. There is no multi-functionality.
10. There will be no drive controls with the override function.
11. The base override mode ignores the following safety functions:
 - 11.1. Platform emergency stop and platform emergency stop fault reactions
 - 11.2. Overload conditions and load sensor fault reactions.
12. It does not override the safe state responses of any other safety functions.
13. The base override mode enables function that are disabled by:
 - 13.1. CAN-disconnected faults at platform ECU (Electronic Control Unit)(base ECU outputs only)
 - 13.2. VIN check failure
 - 13.3. Limit switch faults (enable raise and extend functions, but continue to default to raised state condition)
 - 13.4. Output faults for base and platform ECUs (including safeout faults).
14. The base override mode shall not ignore the base emergency stop.
15. When the basic override mode has been activated, the "historical override activated" icon is displayed. This can only be cleared by a message from ServiceMaster / display to the base ECU.

Platform Control Function Check

General Check from Platform

1. Insert ignition key and turn the ignition key to the ON position.
 - 1.1. The display switches ON the base and platform beeps 3 times.
2. No alarm information should be displayed on screen. Tilt indicator / overweight indicator / user caution / fault indicator should be in OFF condition.

Foot Switch Check

1. Press the foot switch, turn the ignition key, the machine cannot start.
2. Release the foot switch, turn the ignition key, the machine starts normally.
3. Release the foot switch, push control levers, the machine functions are not active.

4. Press the foot switch, push control levers, the machine functions operates correctly.
5. Push a function lever, and then press the foot switch, this machine function is not active.
6. Press the foot switch for 10 seconds and then push each function lever, the machine functions are not active.

Travel / Steer Check

1. Push the travel / steer joystick forward, the machine moves forward. Make sure there is no jerkiness and the machine is running smoothly. Release the joystick and the machine stops moving.
2. Push the travel joystick backwards, the machine moves backwards. Make sure there is no jerkiness and the machine is running smoothly. Release the joystick and the machine stops moving.
3. Check individual limit switches for working height, teleboom extended, teleboom raised and articulated boom raised up 10 feet / 3 m travel speed should be reduced.
4. Press the steer left button on the top of the travel joystick, the wheels should turn to the left whilst the button is pressed.
5. Press the steer right button on the top of the travel joystick, the wheels should turn to the right whilst the button is pressed.

Main Boom Check

1. Push forward the main boom / slew joystick, the main boom raises steadily. The travel alarm sounds.
 - 1.1. Make sure there is no jitter or abnormal sound.
 - 1.2. The rising speed varies depending on the change in joystick movement amplitude. When the joystick movement is small, the speed is low.
2. Push down the main boom toggle switch, the main boom is lowers steadily. The travel alarm sounds.
 - 2.1. Make sure there is no jitter or abnormal sound.
 - 2.2. The lowering speed varies depending on the change in joystick movement amplitude. When the joystick movement is small, the speed is low.

Machine Slew Check

Make sure the slew lock pin is not engaged with the turntable and then start the test as follows:

1. Push the turntable slew joystick to the left, the turntable slews clockwise (from plan view). The travel alarm sounds.
 - 1.1. The slew speed varies depending on the joystick movement amplitude.
 - 1.2. When the telescopic boom is extended, slew is smooth and there is no jerk sound.
 - 1.3. When the joystick movement is small, the speed is low.
2. Push the turntable slew joystick to the right, the turntable slews counter clockwise (from plan view). The travel alarm sounds.
 - 2.1. The slew speed varies depending on the joystick movement amplitude.
 - 2.2. When the telescopic boom is extended, slew is smooth and there is no jerk or abnormal sound.
 - 2.3. When the joystick movement is small, the speed is low.

Articulated Boom Check

1. Push up the articulated boom toggle switch, the articulated boom raises smoothly. The travel alarm sounds.
 - 1.1. Make sure there is no jitter or abnormal sound.
 - 1.2. Make sure that there is no jerk when it is raising to the full extent.

2. Push down the articulated boom toggle switch, the articulated boom lowers smoothly. The travel alarm sounds.

- 2.1. Make sure there is no jitter or abnormal sound.
- 2.2. There is no jerk when it is lowering to the full extent.

Telescopic Boom Extend / Retract Check

1. Push down the telescopic boom toggle switch, the telescopic boom extends. The travel alarm sounds.

- 1.1. Make sure there is no jitter or abnormal sound.

2. Push up the telescopic boom toggle switch, the telescopic boom retracts. The travel alarm sounds.

- 2.1. Make sure there is no jitter or abnormal sound.
- 2.2. Make sure that there is no jerk when it is retracting to the full extent.

Platform Level Check

1. Push up the platform level toggle switch, the basket and jib moves upwards.

2. Push down the platform level toggle switch, the basket and jib moves downwards.

Automatic Levelling Check

1. Make sure that when the main boom is lifting and lowering, levelling happens without jitter or delay.

Platform Rotary Actuator Check

1. Press the platform rotate toggle switch to left, the platform rotates clockwise (from plan view).

2. Press the platform rotate toggle switch to right, the platform rotates counter clockwise (from plan view).

Jib Function Check

1. Push the jib toggle switch up, the jib moves upwards.

2. Push the jib toggle switch down, the jib moves downwards.

Speed Control Function Check

The speed control affects the speeds of the functions operated by the toggle switches and the travel speed, when operating from the platform control panel only.

The speed potentiometer affects all services differently, some lowering operations may not reduce in speed, or may slow down to a lesser extent than others. It is possible that with the potentiometer in the minimum position some services may not move when operated from platform control panel. Adjustment of the potentiometer will ensure smooth movement.

Auxiliary Function Check

1. Make sure that the ignition key is in the ON position.

2. Press and hold the "Auxiliary Power Button" while pushing the boom function button.

- 2.1. Make sure the boom functions normally.
- 2.2. To conserve battery power, test each function through a partial cycle.

Slew Acknowledgement Travel Interlock Check

Make sure the slew lock pin is not engaged with the turntable and then start the test as follows:

1. Slew the turntable outside in forward position. The slew acknowledgement LED (Light Emitting Diode) will start flashing and the travel function will be in-active.

2. Press the slew acknowledgement button, the LED turns solid and the travel function is enabled.
3. Release the foot switch and check the platform slew acknowledge LED is flashing.
4. Slew inside forward position, check the platform slew acknowledge LED is OFF.

Drive and Brake Check

[Refer to: Check \(Operation\) \(Page 124\).](#)

Safety Equipment

Check (Operation)

Safety Function Check

If any of the safety equipment is defective stop using the machine until the defect has been rectified.

Emergency Stop Check

Proper functioning of emergency stop buttons are essential for safe machine operation. An improperly operating emergency stop button will fail to shut off power and stop all machine functions, resulting in a hazardous situation for ground and platform personnel.

1. Turn key to ON position.
2. Push the emergency stop button to OFF position. The display should show that the emergency stop has been pressed, and no machine function should operate.

The platform emergency stop button will stop all machine operation, even if base control is selected. Also, the base control emergency stop button will stop all machine operation, even if the platform control is selected.

The platform emergency stop can be overridden by the ground override control.

[Refer to: Moving a Disabled Machine \(Page 51\).](#)

Tilt Sensor Check

If the machine drives on a slope and the chassis exceeds the maximum rated angle at 5°, an alarm will sound. Travel and boom raise functions will be disabled until the boom is lowered to its stowed position.

[Refer to: General \(Page 38\).](#) The chassis angle is detected by the tilt sensor.

1. Park the machine on firm level ground.
2. Raise/extend the main boom.
3. Push the tilt sensor down on one side until the sensor is tilted at its highest angle. Hold the tilt sensor down at least for the specified duration.
Duration: 1.5s
4. Check that the alarm should sound at the platform and base control, the tilt alarm icon should flash on the platform control and the base control panel

Axle Oscillation

The machine is installed with an oscillating front axle. The machine stability will be affected if the axle locking system is damaged.

1. Make the machine safe.
2. Turn the machine ON.
3. Drive the right front wheel on the barrier at the specified height. The front axle should be free to tilt.
Distance: 150mm
4. Make sure that the other three wheels are on the ground and are at a level position.
5. Extend the telescopic boom to the specified distance.
Distance: 500mm
6. Drive the right front wheel off the barrier. The front axle should be locked.
7. Make sure that the front right wheel remains off the ground.

Main Boom Down Limit Switch

The boom down limit switch is an important safety device that indicates if the machine is at boom raised position or stowed position. Before you check the boom down limit switch operation, make sure that the machine boom is at its stowed position.

1. Raise the main boom from base control or platform control to the specified height.
Distance: 1,130 ± 100mm
2. Check the base control display icon changes from the stowed to boom raised position.
3. Lower the main boom and check display icon changes to the stowed position.

Articulated Boom Down Limit Switch

Articulated boom down limit switch is an important safety equipment that indicates if the machine is at boom raised position or stowed position. Before you check the articulated boom down limit switch operation, make sure that the machine boom is at stowed position.

1. Raise the articulated boom from base control or platform control to specified height.
Distance: 940 ± 100mm
2. Check the base control display icon changes from stowed to boom raised position.
3. Lower the articulated boom and check display icon changed to stowed position.
4. If the display does not change then do not drive the machine with boom raised.

Tele-detect Limit Switch Check

This switch detects the extension and retraction of tele-boom.

1. Make sure that the machine is at its stowed position.
2. Extend the tele-boom from the base control or platform control to the specified distance.
Distance: 200mm
3. Check the display changes from the stowed to the elevated position.
4. Retract the boom and check the display changes to the stowed position.
5. Make a note that the machine will be in stowed position between the specified stroke.
Distance: 0→180mm

Machine Drive Speed Check

The machine maximum speed is limited by software with boom raised position.

1. From the platform control, perform boom operation (articulated/ main boom raise or teleboom extend) so the machine shows raised position.
2. Drive the machine to specified distance and record the speed.
Distance: 10m
3. The machine should cover this speed in not less than the specified duration.
Duration: 40s

Table 16.

Raise or elevated, maximum moving speed	0.9km/h (0.6mph)
---	------------------

Platform Secondary Guarding System Check

1. From platform control, raise the platform by main boom or articulated boom to the boom raised position.
2. Press the secondary guarding system cable and check platform warning LED (Light Emitting Diode) flashes and horn sounds.
3. Check all drive, raise and extend functions are disabled from the base and the platform control.
4. Check all other functions are enabled.
5. Release the secondary guarding system reset switch and check fault indicators are cleared.
6. Check all functions are enabled from the base and the platform.

Weight Sensor Check

1. The platform is calibrated for 300 kg payload.
2. With empty platform condition, the load cell reading on the display should show load as 0 kg and load management as 0%.
3. With 300 kg in platform, the load cell reading on the display should show load as '300 +/- 15 kg' and load management as '100% +/- 5%'.
4. With 315 kg platform overload, the icon turns ON with a horn sound and all functions from the base and platform control panels will be disabled.
5. To reset the load sensing, enough weight must be removed to go below 95% load due to hysteresis.
6. Check all the functions are enabled from the base and platform control panels.

Slew Acknowledge for Enabling Drive

The machine is equipped with a safety feature to detect the machine is in the forward drive position or outside forward drive position.

If the booms are slewed more than the specified angle from the forward position (between the non-steer wheels), drive and steer functions will not be available until the operator acknowledges the slew orientation. Angle: +/- 55 degree.

1. Slew the machine inward, so that it is in the forward drive position and check slew acknowledgement LED is OFF.
2. Make sure that drive is enabled. Drive the machine in forward or reverse
3. Slew the machine outside the forward drive position. Check the slew acknowledgement LED is flashing.
4. Check that drive is disabled.
5. Press the foot pedal and press the slew acknowledgement reset button. Check the slew acknowledgement LED turns on.
6. Check that drive is enabled when the foot pedal remains pressed.
7. Release the foot pedal and check that the LED is flashing and drive is disabled without the slew acknowledgement reset button being pressed.

The main boom, articulated boom and telescopic boom switch position limits are shown below [Refer to Figure 65](#). The combined effect of these limit switch positions is a change in platform height of 1.5m from the fully stowed position. With the jib fully raised, the platform height can be up to 4.9m at the limits of these switch positions.

Figure 65.

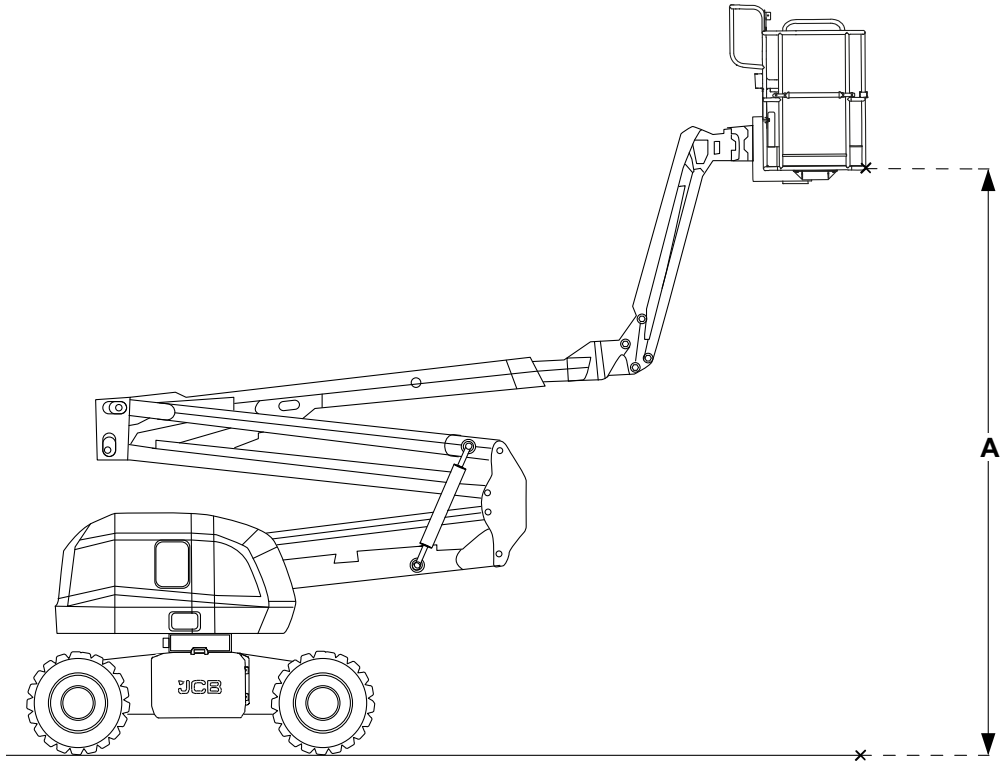

A 4.9m

Engine

General

Clean

Engine

Do not allow mud to build up on the engine and transmission. Pay particular attention to the exhaust area, remove all combustible material.

The engine or certain components could be damaged by high pressure washing systems, special precautions must be taken if the engine is to be washed using a high pressure system.

Do not attempt to clean any part of the engine while it is running. Stop the engine and allow it to cool for at least one hour.

1. Disconnect the battery.
2. Do not wash any part of the:
 - 2.1. Fuel injection pump and injectors.
 - 2.2. Cold start device.
 - 2.3. ESOS (Engine Shut-Off Solenoid) if applicable.
 - 2.4. Electrical connections.
 - 2.5. ECU (Electronic Control Unit) if applicable.
3. Ensure that the alternator, starter motor and any other electrical components are shielded and not directly cleaned by high pressure cleaning system.

Check (Operation)

Start the engine and check for:

- Excessive smoke
- Excessive vibration
- Excessive noise
- Overheating
- Performance
- Unusual smells.

Auto Start / Stop Feature

1. Make the machine safe.
[Refer to: Safety \(Page 3\).](#)
2. Turn the ignition key to position 1.
3. Push the engine start button on the platform control panel to start the engine.
4. When auto start mode is enabled, the engine will automatically start when the BDI (Battery Discharge Indicator) shows 50% or below. The machine will automatically stop the engine when the battery approaches full charge.

Figure 66.



4.1. For optimal battery life, it is recommended to charge the machine fully from an external power supply weekly.

[Refer to: Maintenance Schedules \(Page 85\).](#)

5. Glow plug icon will pop up on the display until the engine starts.
6. The auto start option can be enabled / disabled from the base display and platform control panel.
[Refer to: Instrument Panel \(Page 28\).](#)
7. With auto start mode enabled, the engine will automatically start when BDI is 50% or below, the auto engine start icon (Yellow Colour) will flash on both displays and the buzzer will beep for 5 sec before the engine starts.

Figure 67.



8. When the auto start option is enabled and the engine started, the auto engine start icon will turn solid yellow.
9. When auto start option is enabled and the engine is not running (BDI is more than 50%), auto engine start icon will be solid white.

Figure 68.

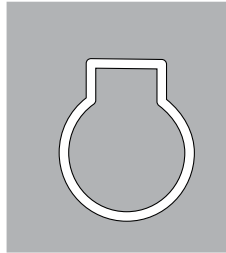

10. When the auto start option is disabled through the platform control panel or base control panel, the auto engine start icon will be solid white with strikethrough.

Figure 69.



Oil

Check (Leaks)

Before you start the machine, do a check for oil leaks:

1. Make the machine safe.
[Refer to: Maintenance Positions \(Page 91\).](#)
2. Get access to the engine compartment (if applicable).
[Refer to: Access Apertures \(Page 94\).](#)
3. Check the engine and the area below for oil leaks.
4. Close the engine cover (if applicable).
5. If necessary, contact your JCB dealer.

Check (Level)

▲ WARNING Never check the oil level or add oil with the engine running. Be careful of hot lubricating oil. Danger of scalding.

Notice: Do not exceed the maximum level of engine oil in the sump. If the maximum is exceeded, the excess must be drained to the correct level. An excess of engine oil could cause the engine speed to increase rapidly without control.

1. Make the machine safe.
[Refer to: Maintenance Positions \(Page 91\).](#)
2. Wait for the oil to drain back into the engine sump before you take a reading. If not, a false low reading may be recorded which can cause the engine to be overfilled.
3. Get access to the engine compartment (if applicable).
[Refer to: Access Apertures \(Page 94\).](#)

4. You must wear suitable PPE (Personal Protective Equipment) when working on the engine otherwise you could be injured.
5. Remove and clean the dipstick.
[Refer to: Service Points \(Page 92\).](#)
6. Install the dipstick.
7. Remove the dipstick.
8. Check the oil level. The oil should be between the two marks on the dipstick.
9. If necessary, add more oil:
 - 9.1. Remove the filler cap.

Figure 70.

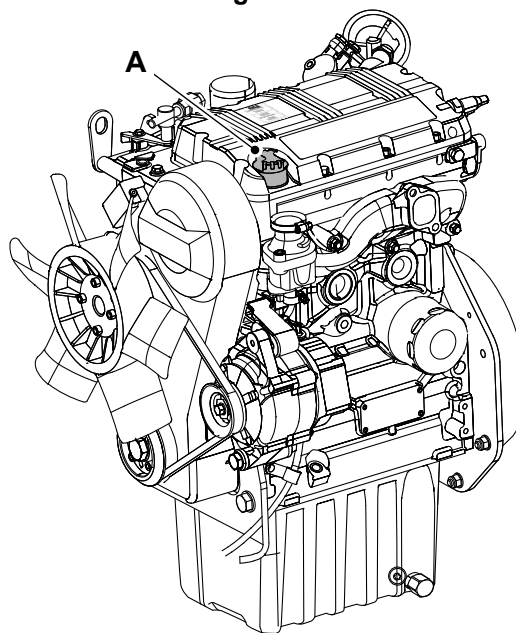

A Filler cap

- 9.2. Add the recommended oil slowly through the filler point
[Refer to: Fluids, Lubricants and Capacities \(Page 156\).](#)
 - 9.3. Install the dipstick.
 - 9.4. Remove the dipstick.
 - 9.5. Check the oil level, if necessary add more oil.
 - 9.6. Install the dipstick
 - 9.7. Install the filler cap.
10. Close and secure the engine cover.

Front End Accessory Drive (FEAD) Belt

Check (Condition)

1. Make the machine safe.
[Refer to: Maintenance Positions \(Page 91\).](#)
2. Let the engine cool.

3. Open the engine compartment cover.
Refer to: [Engine Compartment Cover \(Page 95\)](#).
4. Check the belt condition, if it is cracked, frayed, has missing pieces, or is deteriorated contact your JCB dealer for any service requirements.
5. Make sure the deflection at the midpoint between the alternator and the crankshaft pulley is no more than the value specified. Refer to [Figure 71](#).
Dimension: 7mm
6. If necessary adjust the tension.
 - 6.1. Loosen the alternator mounting bolts, washers and nuts. Do not remove them.
 - 6.2. Pull the alternator outwards to tension the belt.
 - 6.3. Hold the alternator in position and tighten the bolts, washers and nuts.
 - 6.4. Start the engine and let it idle for few minutes.
 - 6.5. Let the engine cool.
 - 6.6. Check the belt tension, adjust again if necessary.
7. Close and secure the engine compartment.

Figure 71.

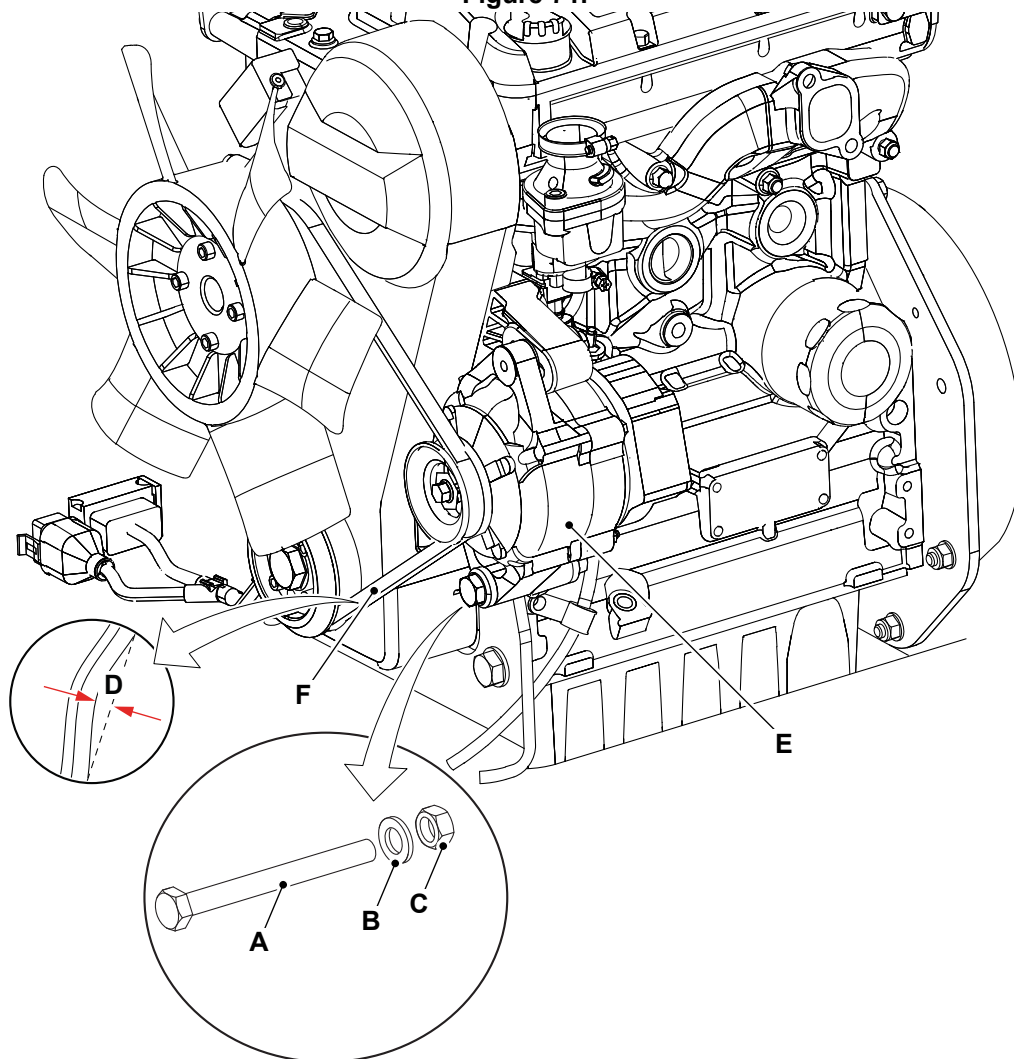

A Bolt

B Washer

C Nut
E Alternator

D Belt movement
F Belt

Exhaust

Check (Condition)

Check that there are no exhaust system components missing.

Check that none of the components are excessively corroded.

Check that there are no leaks in the exhaust system.

Check that the exhaust system is secure.

Air Filter

General

Check (Condition)

1. Make the machine safe.
[Refer to: Maintenance Positions \(Page 91\).](#)
2. Get access to the air filter.
[Refer to: Service Points \(Page 92\).](#)
3. Check the system hoses for:
 - 3.1. Condition.
 - 3.2. Damage.
 - 3.3. Security.
4. Replace the system hoses if necessary.
5. Close the engine cover.

Outer Element

Clean

1. Make the machine safe.
[Refer to: Maintenance Positions \(Page 91\).](#)
2. Get access to the air filter.
[Refer to: Service Points \(Page 92\).](#)
3. Release the end cover latch and remove the cover.
4. Pull out the outer element. Take care not to tap or knock the element as you remove it. If necessary pull out the inner element.
5. Do not clean the air filter elements, they must be replaced at the recommended interval or earlier in arduous environments.
6. Carefully insert the elements into the canister. Make sure that they are seated correctly.
7. Install cover and fasten the latch. Make sure that dust valve is at the bottom.

Figure 72.

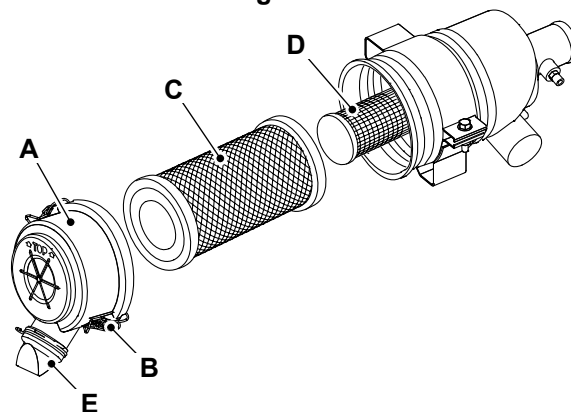

A Cover
C Outer element

B Latch
D Inner element

E Dust valve

Dust Valve

Check (Condition)

- Check the dust valve for rips/tears.
- Check there are no obstructions.
- Check that the dust valve is free of dirt and dust.
- Check that the dust valve securely attached to the air filter housing.

Fuel System

General

Bleed

▲ Notice: Do not allow dirt to enter the system. Before disconnecting any part of the system, thoroughly clean around the connection. When a component has been disconnected, always install protective caps and plugs to prevent dirt ingress.

Failure to follow these instructions will lead to dirt entering the system. Dirt in the system may seriously damage the systems components and could be expensive to repair.

1. Make the machine safe.
2. Get access to the fuel filter.
3. Make sure there is sufficient fuel in the tank.
4. Loosen the bleed screw on the fuel filter.
5. Turn on the ignition until fuel with no air flows freely from the valve, then close the bleed screw.
6. Check the engine for smooth running.
7. If the engine continues to run roughly, check again the bleeding procedure.

Figure 73.

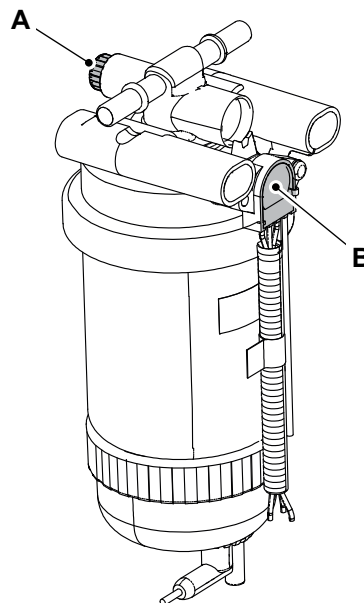

A Bleed screw

B Sensor

Check (Leaks)

1. Make the machine safe.
2. Get access to the engine compartment (if applicable).
3. Check the engine compartment (if applicable), fuel lines and the area below for leaks.
4. If necessary, contact your JCB dealer.

Pre-Filter Element

Replace

1. Make the machine safe.
[Refer to: Maintenance Positions \(Page 91\).](#)
2. Get access to the engine compartment
[Refer to: Access Apertures \(Page 94\).](#)
3. Drain and remove the water separator bowl. To remove the water separator bowl release the locking ring.
[Refer to: Water Separator \(Page 120\).](#)
4. Unscrew and remove the filter element.
5. Fit a new element.
6. Refit water separator bowl and secure in position with the locking ring.
7. Bleed the fuel system.
[Refer to: Bleed \(Page 118\).](#)
8. Close the engine cover.

Figure 74.

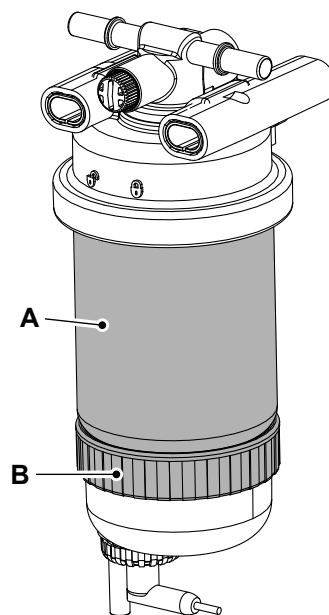

A Filter element

B Locking ring

Engine Fuel Filter

Replace

1. Make the machine safe.
[Refer to: Maintenance Positions \(Page 91\).](#)
2. Get access to the engine compartment.
[Refer to: Engine Compartment Cover \(Page 95\).](#)

3. Unscrew and remove the filter element.
4. Fit a new element.
 - 4.1. Lubricate the O-ring of the new element.
 - 4.2. Do not fill the new cartridge with fuel.
5. Bleed the fuel system.
6. Close the engine cover.

Figure 75.

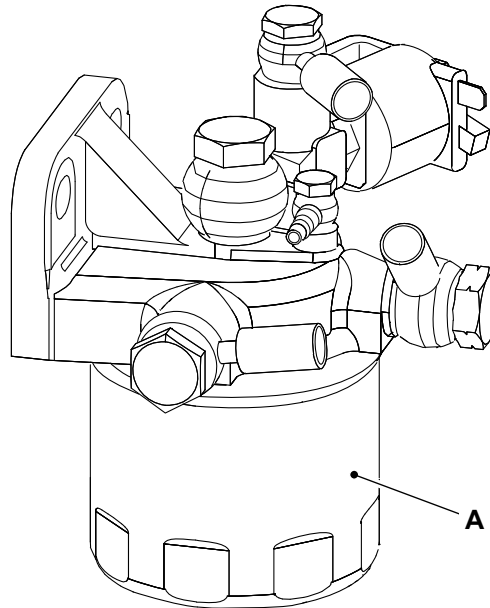

A Filter element

Water Separator

Clean

Draining the Water Separator

1. Make the machine safe.
2. Get access to the engine compartment
3. If there is water but no sediment, open the tap to drain the water. If there is any sediment in the bowl replace the fuel filter element.
4. Close the engine cover.

Figure 76.

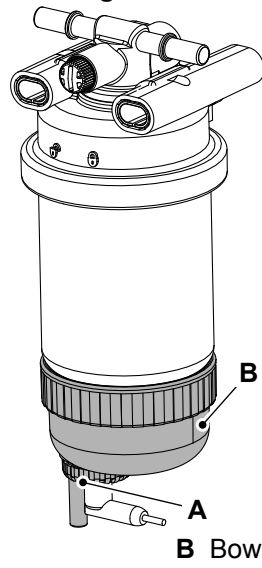

A Tap

B Bowl

Cooling System

General

Check (Leaks)

▲ **CAUTION** The cooling system is hot when the machine is running. Allow the machine to cool down to perform the service tasks.

Before you start the machine, inspect the system for leaks:

1. Make the machine safe.
[Refer to: Maintenance Positions \(Page 91\).](#)
2. Get access to the cooling pack.
[Refer to: Access Apertures \(Page 94\).](#)
3. Check the cooling system for leaks.
4. If necessary, contact your JCB dealer.

Coolant

Check (Condition)

▲ **Notice:** Check which coolant type is installed in the machine before topping up the coolant. Mixing of different coolant types is not recommended and may result in invalidation of the warranty offered by JCB. In the event of mixing or if the coolant type is to be changed, the coolant circuit should be completely drained and flushed twice with clean water before re-filling with fresh coolant.

[Refer to: Coolant \(Page 158\).](#)

Check (Level)

▲ **CAUTION** The cooling system is pressurised when the coolant is hot. If you remove the cap, hot coolant can spray out and burn you. Make sure that the engine is cool before you work on the cooling system.

1. Make the machine safe.
2. Let the engine cool.
3. Get access to the radiator
[Refer to: Service Points \(Page 92\).](#)
4. Check the coolant level in the radiator.
 - 4.1. Carefully loosen the cap on the radiator and let the pressure release from the system.
[Refer to: Service Points \(Page 92\).](#)
 - 4.2. Remove the cap from the radiator.
 - 4.3. Top up radiator with coolant if necessary.
[Refer to: Fluids, Lubricants and Capacities \(Page 156\).](#)
 - 4.4. Replace the cap.
5. Start the engine and run the engine up to operating temperature.
6. Stop the engine.
7. Remove the ignition key.
8. Check for leaks.

Cooling Pack

Clean

1. Make the machine safe.
[Refer to: Maintenance Positions \(Page 91\).](#)
2. Let the engine cool.
3. Get access to the cooling pack.
[Refer to: Access Apertures \(Page 94\).](#)
4. If necessary, use a soft bristle brush or compressed air to remove all debris from the cooling pack.

Check (Condition)

1. Make the machine safe.
[Refer to: Maintenance Positions \(Page 91\).](#)
2. Let the engine cool.
3. Get access to the radiator.
[Refer to: Service Points \(Page 92\).](#)
4. Check the condition of the coolant hoses.
5. Check the radiator and intercooler surfaces for signs of damage.
6. If necessary, contact your JCB dealer for any service requirements.

Brakes

General

Check (Operation)

The brakes must be able to hold the machine on any slope it is able to climb up to the permissible value.
[Refer to: Driving on Slopes \(Page 34\).](#)

Make a note of the following.

- You must check the brakes for correct operation at regular intervals.
[Refer to: Maintenance Schedules \(Page 85\).](#)
 - The correct brake function is necessary for safe machine operation.
 - The brake function must operate smoothly, free of hesitation, jerking and unusual noise.
 - Carry out this procedure with the machine on a firm, level surface that is free of obstructions.
1. Make the machine safe with the platform lowered.
 2. Put a mark on the ground to use as a test line.
 3. Turn the ignition switch to platform control.
 4. Release the base emergency stop button to the ON position.
 5. Release the platform emergency stop button to the ON position.
 6. Make a note of the point on the machine (contact patch of a tyre) as a visual reference when you cross the test line.
 7. Press the drive function button (if installed).
 8. Press and hold the drive / steer function enable switch on the control handle.
 9. Move the control lever in the forward direction.
 10. Bring the machine to top drive speed before you reach the test line.
 11. Release the control lever when the selected reference point on the machine crosses the test line.
 12. Measure the distance between the test line and the machine reference point.
 13. Make sure that the braking distance is within the specified limits.
 14. Raise the platform.
 15. Do the steps 2 to 12 with the platform raised.
 16. Make sure that the braking distance is within the specified limits.
[Refer to: General \(Page 151\).](#)

Steering System

Steering

Check (Operation)

1. Enable the joystick by pressing the foot pedal switch at platform.
[Refer to: Main Component Locations \(Page 7\).](#)
2. Press the joystick (forward/back).
3. Press the left steering switch to turn left.
4. Press the right steering switch to turn right.

Wheels

Check (Condition)

▲ WARNING A raised and badly supported machine can fall on you. Position the machine on a firm, level surface before raising one end. Ensure the other end is securely chocked. Do not rely solely on the machine hydraulics or jacks to support the machine when working under it. Disconnect the battery, to prevent the machine being started while you are beneath it.

WARNING A machine can roll off jacks and crush you unless the wheels have been blocked. Always block the wheels at the opposite end of the machine that is to be jacked. Do not work underneath a machine supported only by jacks. Always support a jacked-up machine on axle stands before working underneath it.

WARNING Wheels and tyres are heavy. Take care when lifting or moving them. Store with care to ensure that they cannot fall and cause injury. Use suitable lifting equipment if necessary.

Daily Inspection

Prior to machine use, walk around machine and visually check the lug nut torque marks are in line with the markings on the wheel. If any of the marks are not aligned, then re-torque all the lug nuts. Remove and reapply the torque marks.

Figure 77.

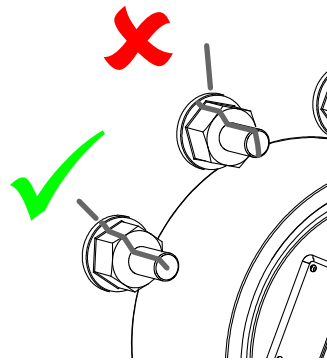

Checking the Wheel Lug Nut Torques

▲ WARNING You must check the lug nut torques:

- after the first 50 hours of operation.
- after removal and replacement of a wheel.
- if the lug nut torque marks are out of line.
- every 250 hours of operation.

If wheel/s are re-torqued then the existing marks must be removed and reapplied.

Changing a Wheel

Removal

1. Make the machine safe.
[Refer to: Maintenance Positions \(Page 91\).](#)
2. Jack up the machine to gain access to the wheel to be changed. Ensure the tyre is not touching the ground.
3. Remove the lug nuts and then remove the wheel.

Replacement

1. Inspect the wheel for any damage, i.e. dents, elongated holes, corrosion etc.

2. Clean the wheel hub and wheel inner mounting face.
3. Ensure the wheel hub stud threads are free from oil and grease.
4. Position the wheel on to the hub centrally, ensuring the mating face on the rear of the wheel is fully pushed back and flush with the wheel hub; the tyre must not be touching the ground.
5. Tighten all lug nuts pushing the wheel back in to place.
6. Lower the machine to the ground.

Figure 78.

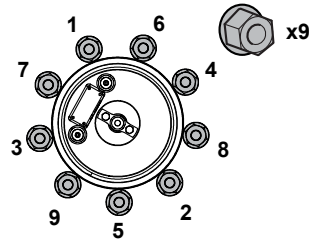

7. Torque tighten the lug nuts in the sequence shown to 250Nm (184 ft lbs).
8. Remove and reapply the torque marks.

Tyres

General

Check (Condition)

Always drive with consideration for the condition of the tyres. Check the tyres daily for the signs of damage and wear. For example:

- Signs of distortion
- Cuts
- Embedded objects (nails, etc.)
- Continuous tread
- Edge damage
- Uneven wear
- Compare wear between tyres

Never modify tyres or install tyres which are not intended for use on this machine. Contact you local JCB dealer to replace the parts.

Changing specification of tyres may require a change of counterweight, check with your JCB dealer.

Hydraulic System

Oil

Check (Level)

1. Make the machine safe with the boom lowered.
2. Get access to the hydraulic oil level indicator and hydraulic oil filler cap.
[Refer to: Service Points \(Page 92\).](#)
3. Check the hydraulic oil level indicator. The hydraulic oil level must be visible in the level indicator.
4. Make sure that the hydraulic oil does not exceed specified temperature on the hydraulic tank gauge.
Temperature: 80°C (175.9°F)
5. Top up oil level if necessary:
 - 5.1. Remove the hydraulic oil filler cap.
 - 5.2. Add hydraulic oil.
[Refer to: Fluids, Lubricants and Capacities \(Page 156\).](#)
 - 5.3. Install the filler cap.

Electrical System

General

Check (Operation)

Make sure all of the electrical equipment operates correctly, for example:

- Switches
- Warning lights
- Beacon
- Alarms
- Horn
- Hourmeter/display
- Battery
- Lights

All defective equipment must be repaired before the machine is used.

Limit Switches and Boom Position Indicator

1. There must be two main states of the machine.
 - 1.1. Stowed Mode
 - 1.2. Raised Mode
2. The machine state must be identified by, telescope retract limit switch, articulated lower limit switch proximity sensor and main boom lower limit switch (Raised mode must be 'OR' Condition).
3. If all of these switches indicate that all of these booms are in the stowed position, the Base ECU (Electronic Control Unit) must log that the machine is in the "stowed mode" (Stowed mode must be 'AND' condition).
4. There is an icon at base display to show the correct operating state of machine to the operator. Refer Base Control display in
[Refer to: Instrument Panel \(Page 28\)](#).
5. Under any of proximity sensor and limit switch's fault condition, the default working state is set to raised mode.

Check (Condition)

▲ WARNING Battery electrolyte is toxic and corrosive. Do not breathe the gases given off by the battery. Keep the electrolyte away from your clothes, skin, mouth and eyes. Wear safety glasses.

DANGER Batteries give off explosive gases. Keep flames and sparks away from the battery. Do not smoke close to the battery. Make sure there is good ventilation in closed areas where batteries are being used or charged. Do not check the battery charge by shorting the terminals with metal. Use a hydrometer or voltmeter.

CAUTION Understand the electrical circuit before connecting or disconnecting an electrical component. A wrong connection can cause injury and/or damage.

Examine the electrical circuits regularly for:

- Damaged connectors
- Loose connections
- Chafing on the wiring harnesses
- Corrosion
- Missing insulation
- Incorrect routing of the wiring harnesses
- Insulation covers on battery terminals and leads

Do not use the machine if one or more of these faults are found. You must make sure that the electrical circuit is repaired immediately.

Battery

Clean

▲ WARNING Keep metal watch straps and any metal fasteners on your clothes, clear of the positive (+) battery terminal. Such items can short between the terminal and nearby metal work. If it happens you can get burned.

1. Make the machine safe.
2. Get access to the battery.
3. If the terminal posts are corroded and covered with white powder wash them with hot water. If there is considerable corrosion, clean the terminal posts with a wire brush or abrasive paper. [Refer to Figure 79.](#)

Figure 79.

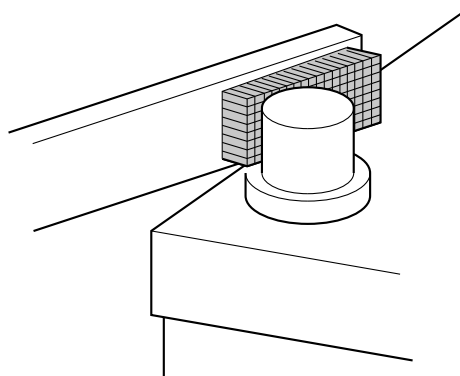

4. Apply a thin layer of petroleum jelly to the terminal posts.

Connect

▲ WARNING Keep metal watch straps and any metal fasteners on your clothes, clear of the positive (+) battery terminal. Such items can short between the terminal and nearby metal work. If it happens you can get burned.

CAUTION The machine is negatively earthed. Always connect the negative pole of the battery to earth.

When connecting the battery, connect the earth (-) lead last.

When disconnecting the battery, disconnect the earth (-) lead first.

CAUTION Understand the electrical circuit before connecting or disconnecting an electrical component. A wrong connection can cause injury and/or damage.

12V Battery

1. Make the machine safe.
[Refer to: Maintenance Positions \(Page 91\).](#)
2. Open the hydraulic compartment cover to access the battery.
[Refer to: Access Apertures \(Page 94\).](#)
3. Connect the battery cables.

Figure 80.

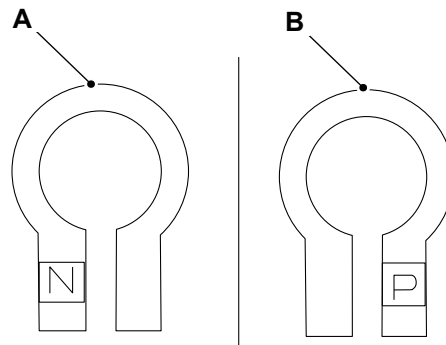

A Negative terminal clamp

B Positive terminal clamp

- 3.1. Connect the positive terminal first then the negative terminal.
- 3.2. Battery terminal should make full contact with cable clamp.
- 3.3. Connect cable clamps to respective positive and negative battery terminal according to mark on cable clamp. (Positive and Negative battery terminal sizes are different for error proofing.)

4. Use the battery isolator to connect the battery.

48V Batteries

1. Make the machine safe.
[Refer to: Maintenance Positions \(Page 91\).](#)
2. Open the battery cover to access the batteries.
[Refer to: Access Apertures \(Page 94\).](#)
3. Connect the battery link leads and battery cables. [Refer to Figure 81.](#)
 - 3.1. Connect the battery positive terminal first then the negative terminal. [Refer to Figure 81.](#)
4. Use the battery isolator to connect the battery.

Figure 81.

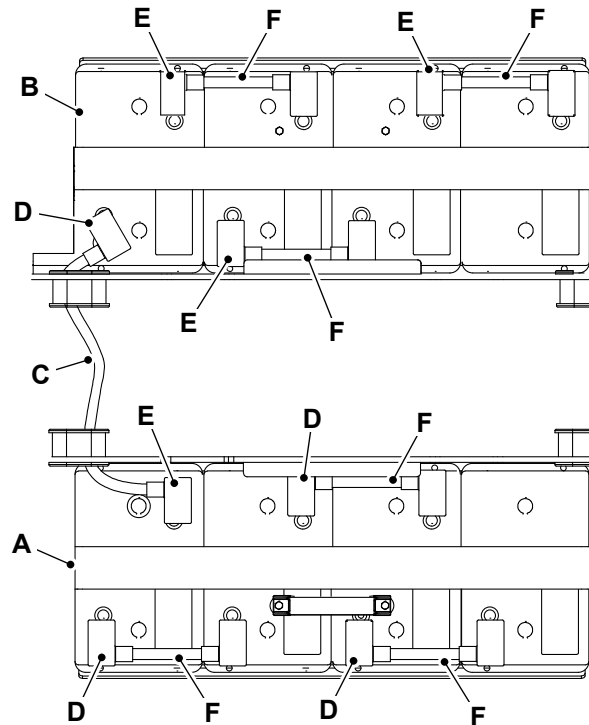

A Left side batteries
C Battery cable
E Positive terminal

B Right side batteries
D Negative terminal
F Battery link leads

Disconnect

▲ WARNING Keep metal watch straps and any metal fasteners on your clothes, clear of the positive (+) battery terminal. Such items can short between the terminal and nearby metal work. If it happens you can get burned.

CAUTION The machine is negatively earthed. Always connect the negative pole of the battery to earth.

When connecting the battery, connect the earth (-) lead last.

When disconnecting the battery, disconnect the earth (-) lead first.

CAUTION Understand the electrical circuit before connecting or disconnecting an electrical component. A wrong connection can cause injury and/or damage.

12V Battery

1. Make the machine safe.
[Refer to: Maintenance Positions \(Page 91\).](#)
2. Turn the battery isolator switch to the OFF position.
[Refer to: Service Disconnect \(Page 24\).](#)
3. Open the hydraulic compartment cover to access the battery.
[Refer to: Access Apertures \(Page 94\).](#)
4. Disconnect the battery cables.
 - 4.1. Disconnect the battery negative terminal first then the positive terminal.

48V Batteries

1. Make the machine safe.

Refer to: [Maintenance Positions \(Page 91\)](#).

2. Turn the battery isolator switch to the OFF position.

Refer to: [Service Disconnect \(Page 24\)](#).

3. Open the battery cover to access the batteries.

Refer to: [Access Apertures \(Page 94\)](#).

4. Disconnect and remove the battery link leads and battery cables.

4.1. Disconnect the battery negative terminal first then the positive terminal. Refer to [Figure 82](#).

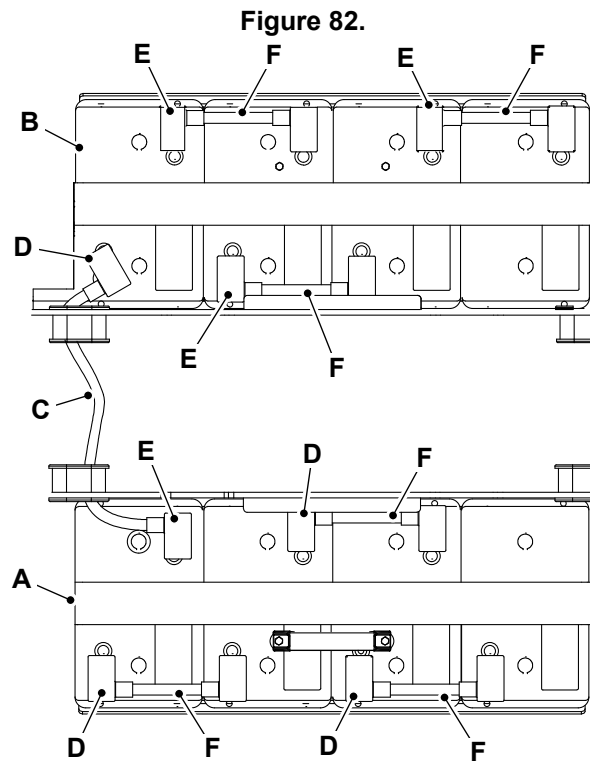

A Left side batteries
C Battery cable
E Positive terminal

B Right side batteries
D Negative terminal
F Battery link leads

Check (State of Charge)

General Check (Before Charging)

- The battery charge level is displayed on the instrument panel. (while the machine is not charging).
Refer to: [Instruments \(Page 28\)](#).
- Battery charge level (%) can be checked at base and platform display.
- For checking the battery charge level turn OFF the engine (if ON) and remove the external charging connector (if connected).
- Reset the ignition key (turn OFF and then turn ON) to check the battery charge level.
- Charge the battery fully after each use.
- Do not charge, when the ambient temperature is above 46°C (114.7°F).
- Do not use an external charger.
- The battery is only suitable for this particular product. Never use this battery with other equipment.
- Do not short-circuit the battery output.
- Do not immerse the battery in water, acid, alkaline or a salt solution.

Battery Charging from AC Power Supply

1. Park the machine in an appropriate charging area.

- 1.1. Make sure that the charging area is covered and duly ventilated.
2. Switch OFF the ignition, remove the key and isolate the machine.
3. Connect the power supply to the charging cable connector.

Figure 83.

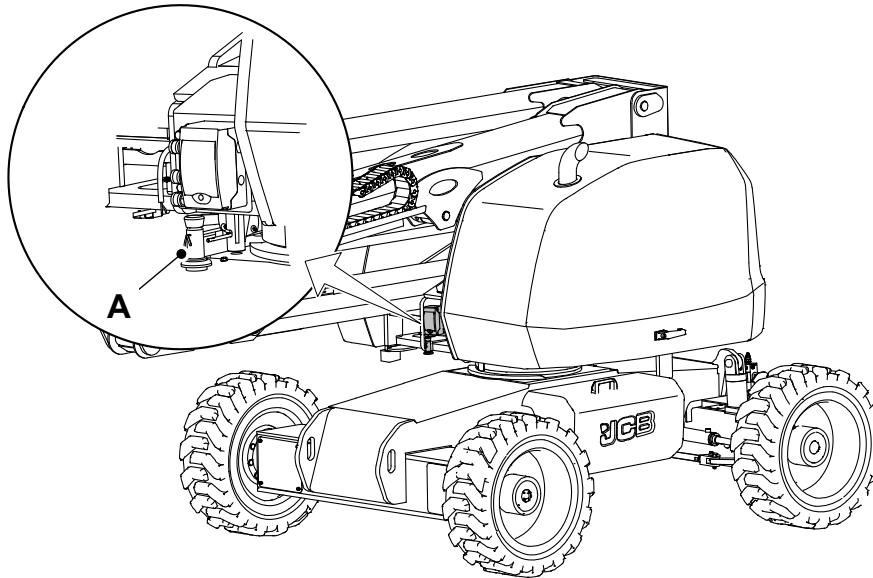

A Charging connector

4. Switch ON the power supply.
5. Wait until charging has completed.
Duration: 8h
6. To check battery charge level disconnect battery charge cable and reset ignition key.
7. For optimal battery life, it is recommended to charge the machine fully from an external power supply weekly.
[Refer to: Maintenance Schedules \(Page 85\).](#)

Figure 84.

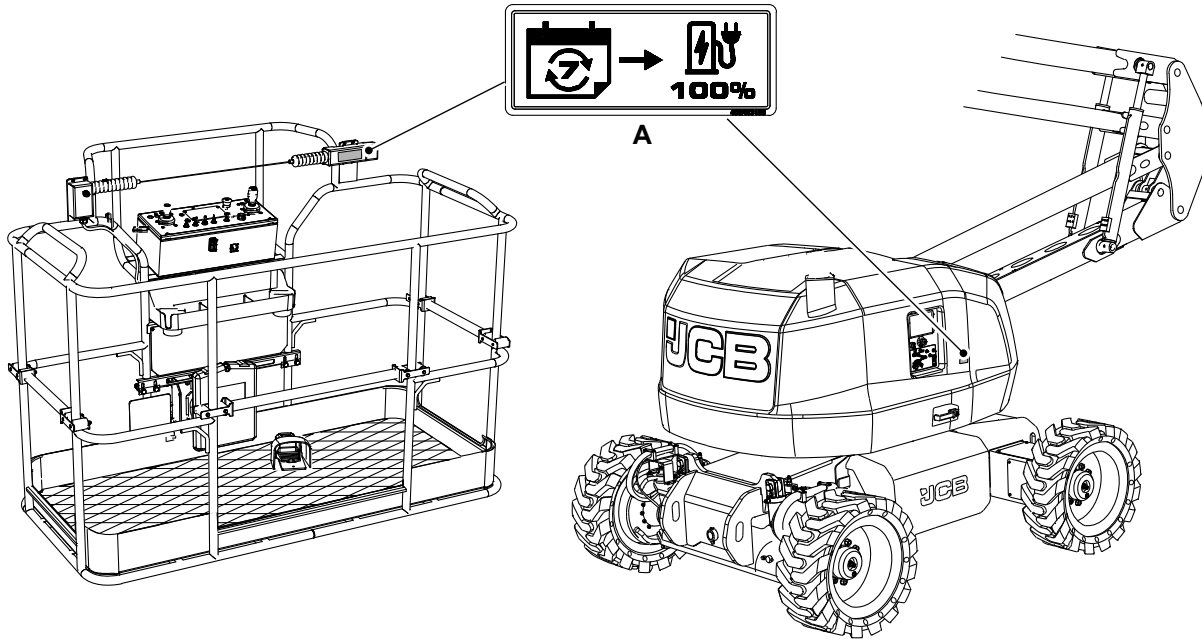

A Battery recharge decal (located at platform and adjacent to base control panel)

Battery Charging from Generator

- Engine and alternator works as the electric power generator on the machine for charging the batteries and powering the tools at the platform.
- At a time, the operator can either charge the batteries or use power tools at the platform.
- For normal operation of the machine, engine running is not required.
- By default, at the engine start, alternator power will be used for the battery charging. To use the power tool at the platform, push the power to platform switch at the platform control panel.

Figure 85.

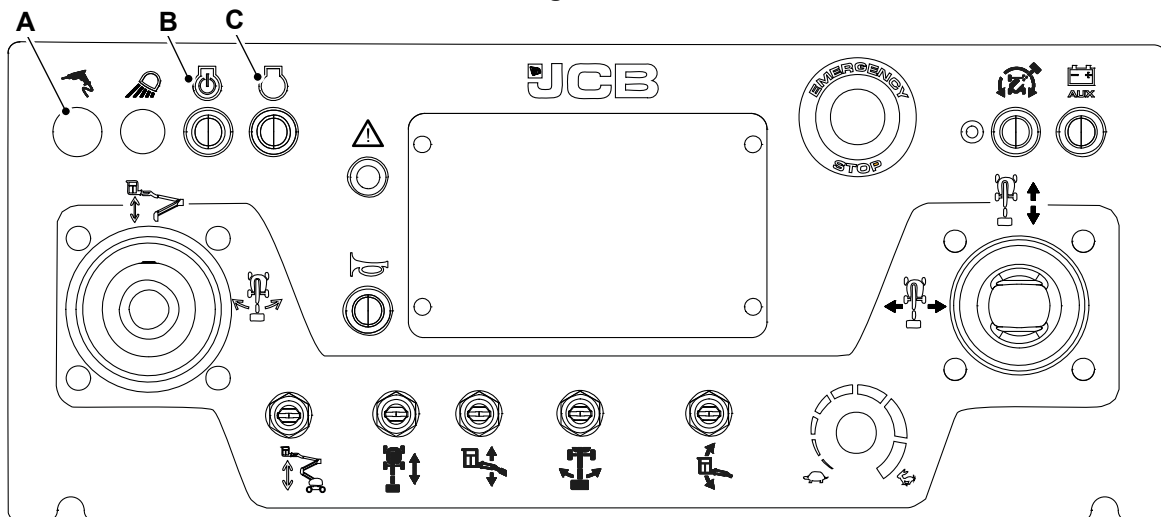

A Power to platform switch
B Engine ON / OFF switch
C Auto engine start enable / disable push button

1. Auto engine start feature is enabled in the machine at every key cycle.
 - 1.1. The engine will start automatically when the battery charge level drops below 50%.

- 1.2. When auto start mode is enabled, the engine will automatically start when the BDI (Battery Discharge Indicator) shows 50% or below. The machine will automatically stop the engine when the battery approaches full charge.
- 1.3. For optimal battery life, it is recommended to charge the machine fully from an external power supply weekly.

[Refer to: Maintenance Schedules \(Page 85\).](#)

2. When charging with the generator, both chargers will work together to facilitate fast charging.

Service Disconnect

Check (Operation)

▲ Notice: Do not isolate the machine electrics when the machine is in operation, this may cause damage to the machine electrics.

1. Isolate the machine electrics.
[Refer to: Service Disconnect \(Page 24\).](#)
2. Make sure that the machine electrics are isolated.

A defective isolator must be repaired before the machine is used. For more information, contact your JCB dealer.

Fuses

Replace

▲ Notice: Always replace fuses with ones of correct ampere rating to avoid electrical system damage.

For more information on the individual fuses.

[Refer to: Fuses \(Page 160\).](#)

The electrical circuits are protected by fuses. If a fuse blows, find out why before a new one is installed.

Busbar and harness Fuses

The busbar and harness fuses are situated inside the rear chassis cover. Remove the rear chassis cover to get access to the fuses.

Figure 86.

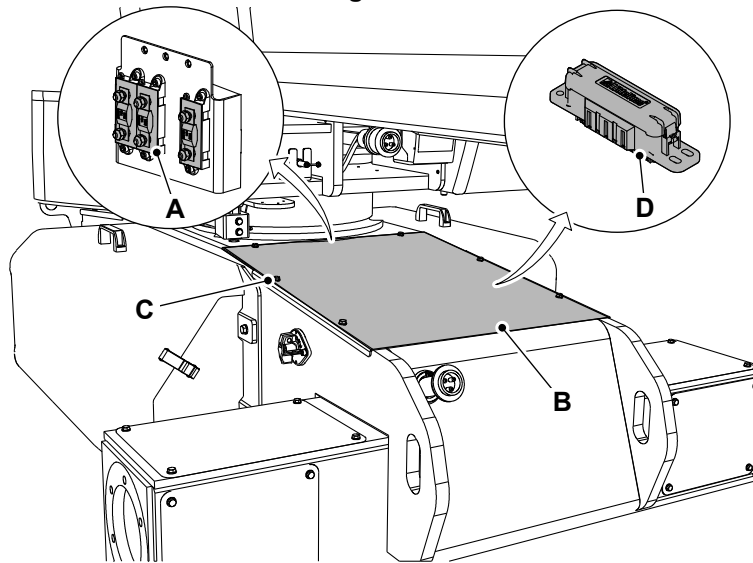

A Busbar fuses
C Screws

B Rear chassis cover
D Harness fuses

Base Control Panel Fuses

Open the base control panel to get access to the fuses.

Figure 87.

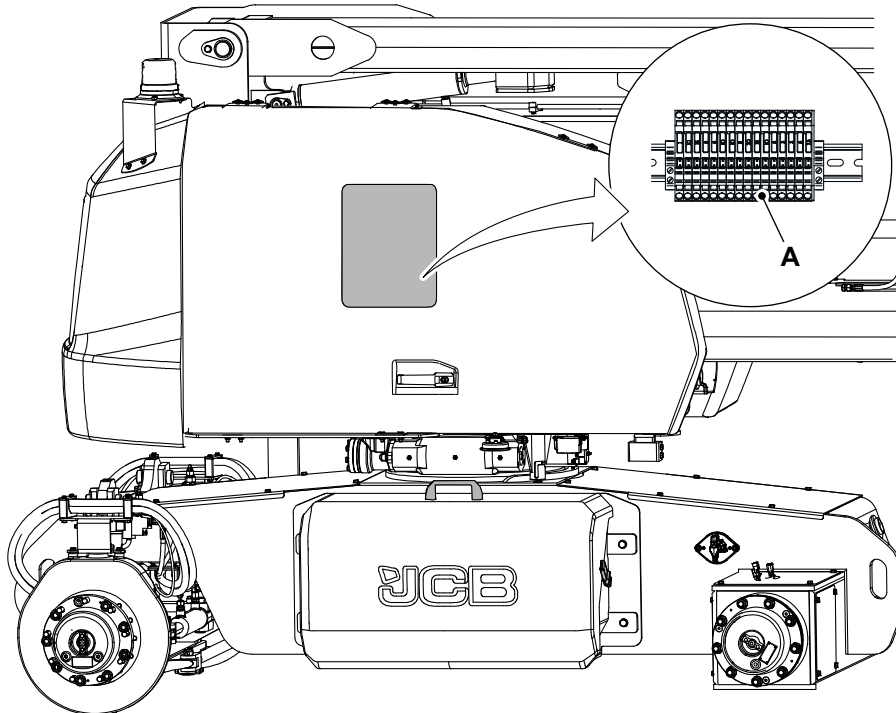

A Base control fuses

Platform Control Fuse

Open the platform control panel to get access to the platform control fuse.

Figure 88.

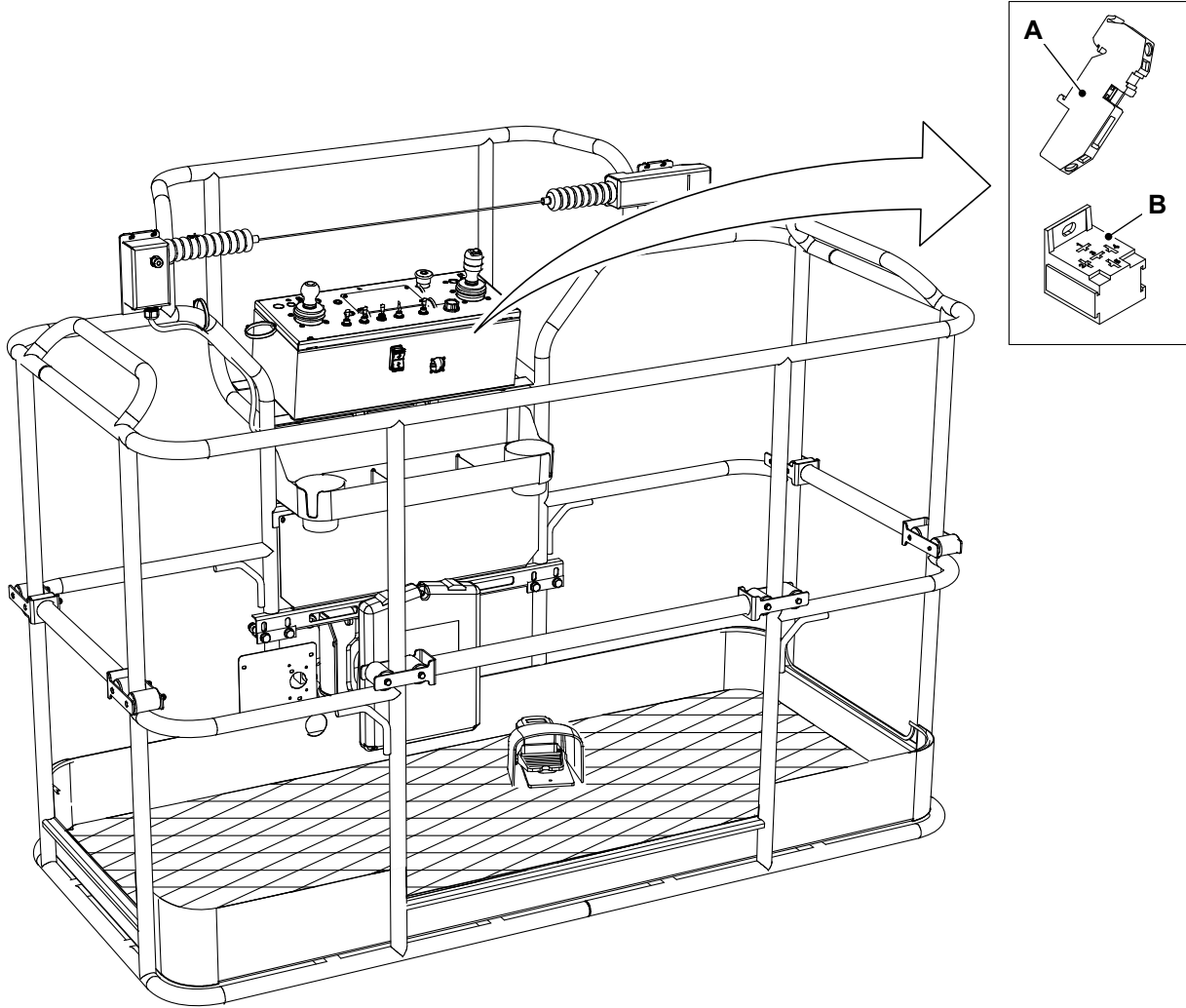

A Platform control fuse

B Platform control relay

Engine Fuse

Open the engine side cover plate to get access to the engine fuses.

Figure 89.

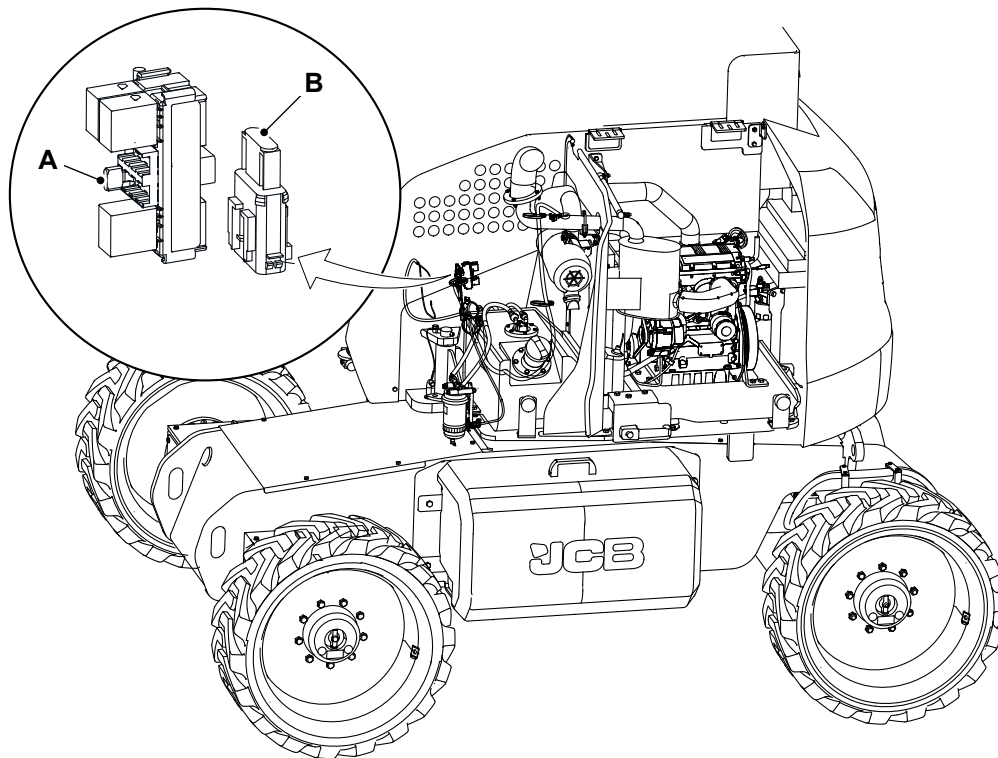

A Mini fuse 10A

B Mini fuse 40A

Relays

Replace

For more information on the individual relays.
Refer to: [Relays \(Page 162\)](#).

Base Control Relays

Open the base control panel to get access to the base control relays.

Figure 90.

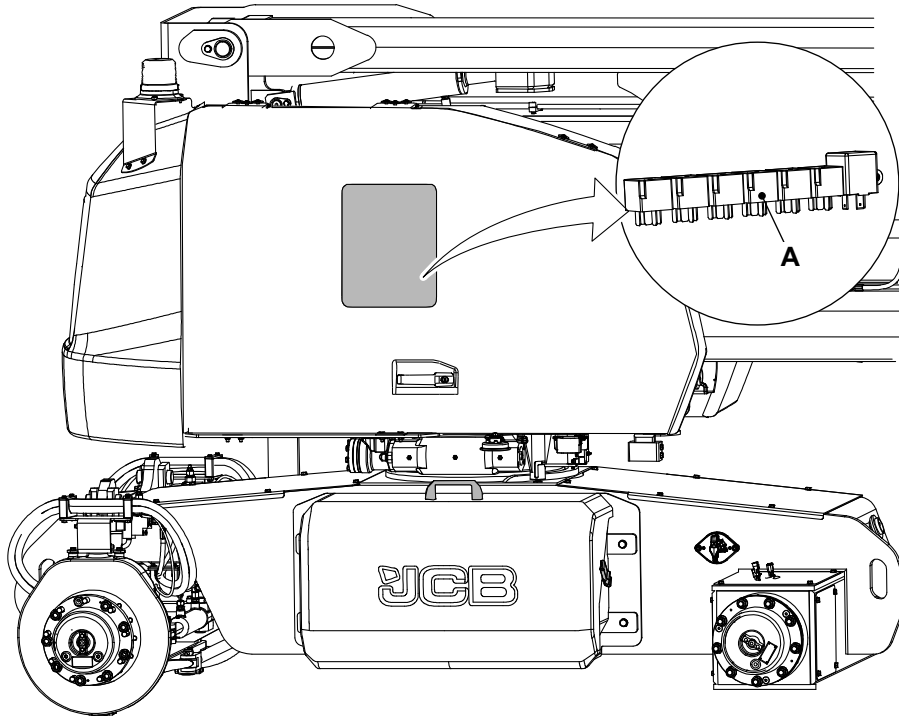

A Relays

Platform Control Relay

Open the platform control panel to get access to the platform control relay.

Figure 91.

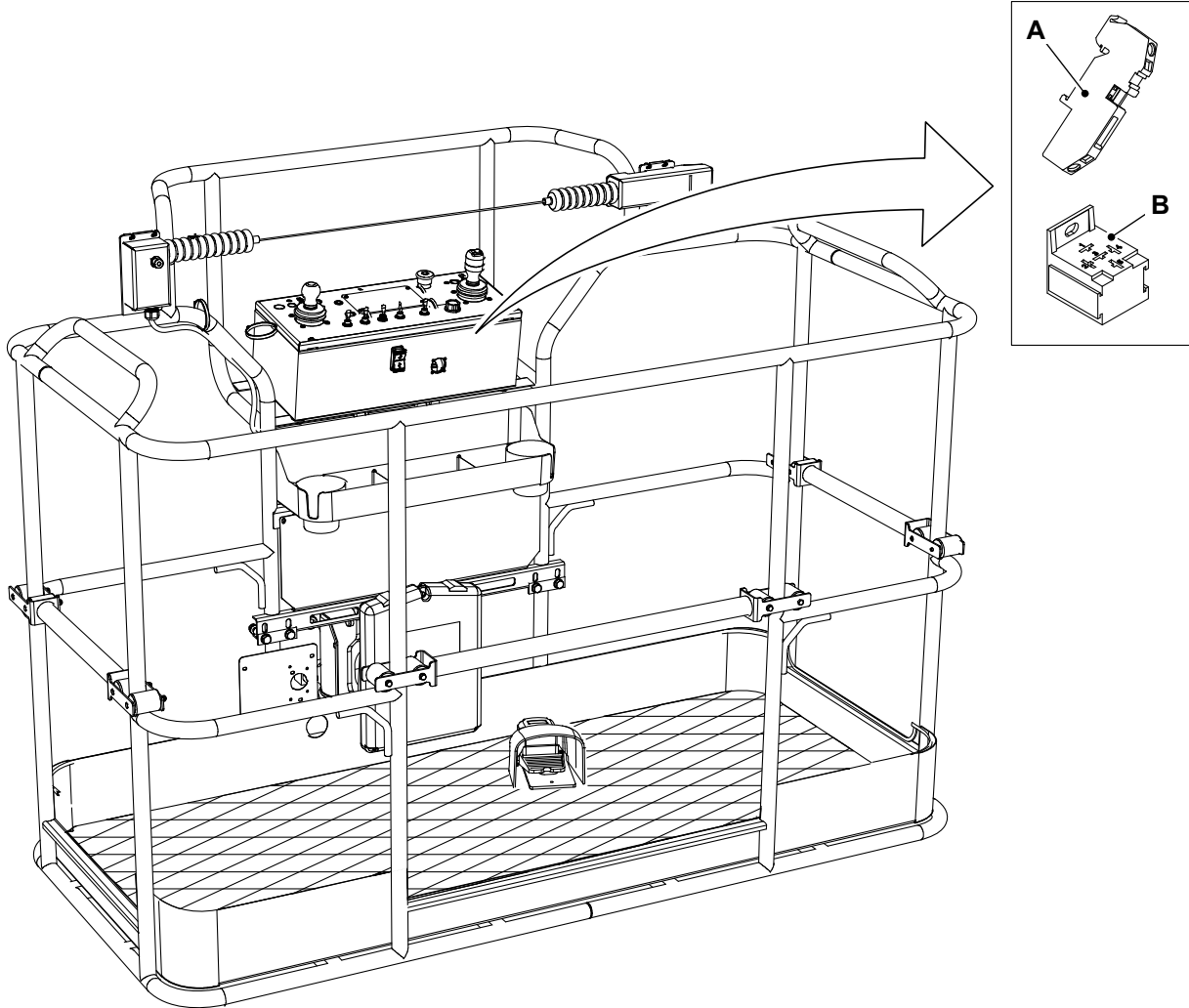

A Platform control fuse

B Platform control relay

Engine Relay

Open the engine side cover plate to get access to the engine relays.

Figure 92.

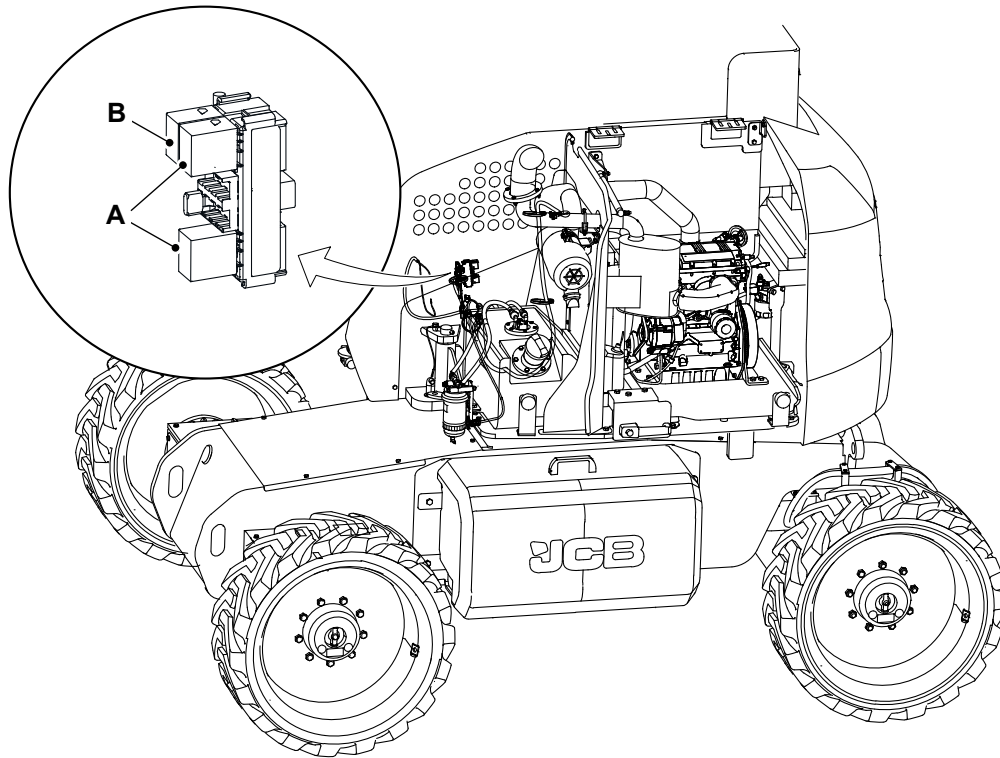

A High capacity micro relay

B Micro relay 35 / 20A



Technical Data

Introduction

General

All the rated operating capacities/rated lift capacities are based on the criteria of the machine being level on a firm supporting ground and wind speed is below the specified limit.

JCB © CONNOR STANMORE - 13/03/2026 07:54.

Static Dimensions

Dimensions

Figure 93.

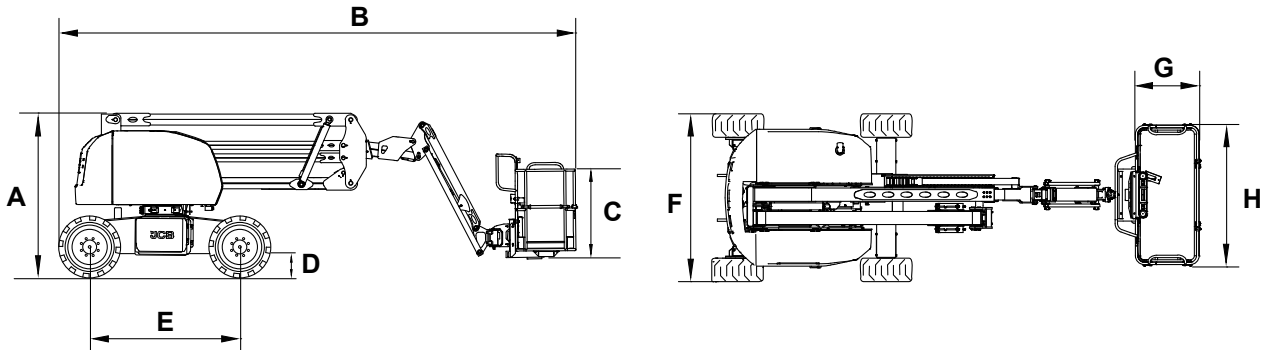

Figure 94.

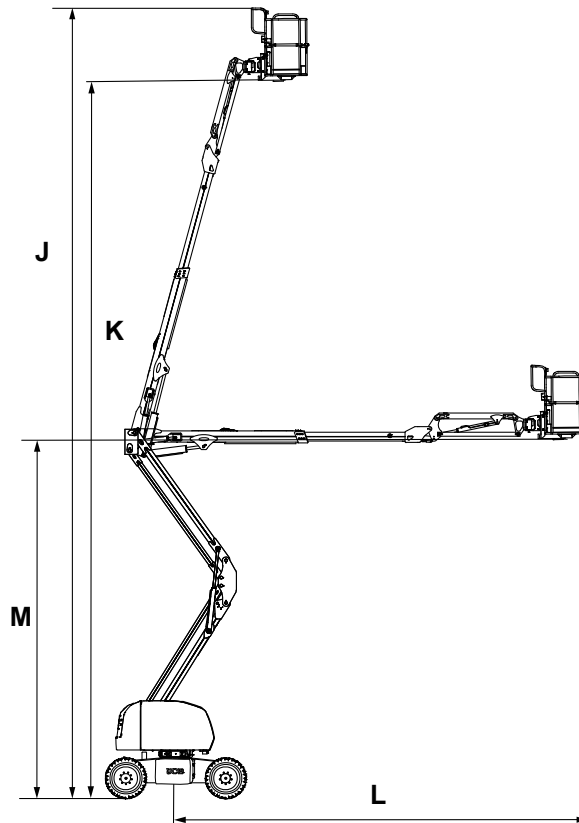

Table 17.

Items	Description	Length
A	Height-stowed	2.23m (7ft 3.8in)
B	Length-stowed	7.04m (23ft 1.2in)
C	Platform height	1.2m (3ft 11in)
D	Ground clearance	0.32m (1ft 0.6in)
E	Wheelbase	2.03m (6ft 7in)
F	Width	2.26m (7ft 4in)
G	Platform- width	1.9m (6ft 3in)
H	Platform-length	0.85m (2ft 9in)

Items	Description	Length
J	Maximum working height	15.5m (50ft 10in)
K	Maximum platform height ⁽²⁾	13.8m (45ft 3in)
L	Maximum horizontal reach	8.05m (26ft 5in)
M	Up and over clearance ⁽¹⁾	7.5m (24ft 7in)

(1) The maximum height that the basket can reach when the main telescopic boom is angled horizontally.

(2) Maximum working height adds 2m to the metric platform height, and adds 6ft to the imperial platform height, based on regional norms.

Weights

Table 18.

Description	Weight
Overall weight (approximate)	8,032kg
Load capacity	300kg
Platform entry type	Drop bar
Platform entry number	3
Platform occupancy	2 persons
Maximum manual force	400N
Maximum ground wheel load	4,230kg
Maximum localised ground pressure per tyre	5,798 kN/m ²

Visibility Diagrams

The visibility maps provided in this manual are for guidance, and may be used to improve visibility or as part of a risk assessment for work site safe operation, introduction of additional visual aids or site management.

The visibility map(s) show machines in standard configuration. Modifications or environment may increase or add blind spots around the machine. It is the responsibility of the operator and worksite management to determine if the visibility for the machine in its worksite is acceptable.

The visibility map(s) shows the combined approximate blind spots of direct vision. The operator's eye position is 1.62m above the platform floor, 0.4m in from the side and 0.5m in from the front of the platform. This represents what a standing operator can approximately see from the front-right default controller position.

Dimension for Setup

The evaluation has been completed from the eye point of the operators as they stand on the access platform at the control box.

Figure 95.

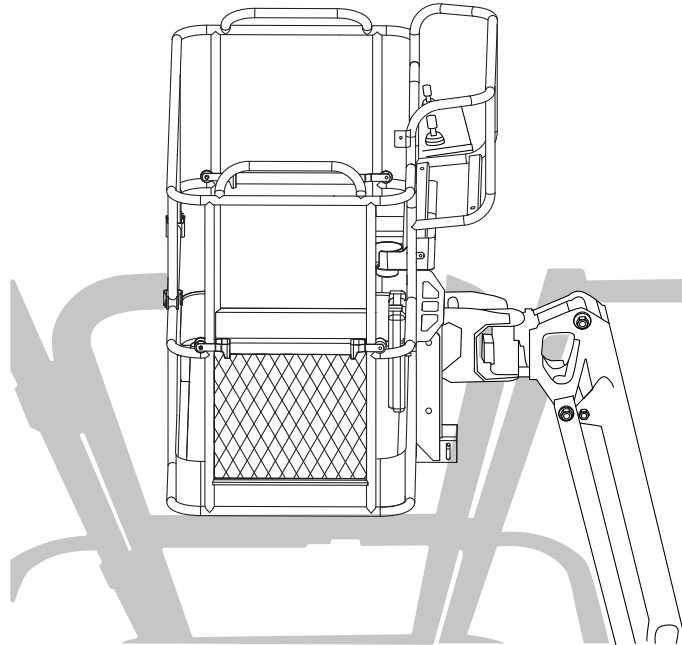

Average Height Operator

The grey areas shown in the image on the left and the shaded areas around the machine in the image on the right highlight the areas that cannot be seen by the operator when they are stood on the access platform.

Figure 96.

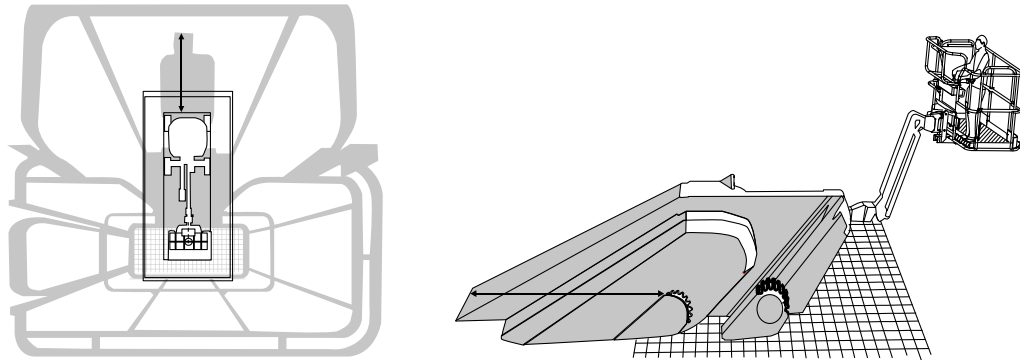

Distance from the front of the machine to the most forward edge that cannot be seen behind the counterweight (shown by the arrows) = 4.274m (14ft).

JCB © CONNOR STANMORE - 13/03/2026 07:54.

Performance Dimensions

General

Table 19. Drive Speed Checks

Description	Data
Maximum stowed drive speed	7km/h (4.3mph)
Maximum elevated drive speed (kph)	0.9km/h (0.6mph)
Maximum wind speed	12.5m/s
Maximum inclination (front/ side/ rear)	5°
Maximum gradeability	40%
Turning radius (outside)	4.7m
Turning radius (inside)	2.7m
Drive and steer	4WD, 2WS
Brake	4 nos

Table 20. Check Cycle Time

Parameters		Motor RPM		Cycle time in Seconds	
		Base	Platform	Base	Platform
Articulated boom	Raise	1500	1730	29±3	26±3
	Lower	1500	1500	40±3	40±3
Main boom	Raise	1500	1730	27±3	24±3
	Lower	1500	1270	21±3	21±3
Telescopic boom horizontal	Extend	1500	1900	18±2	13±2
	Retract	1500	1975	11±2	11±2
Telescopic boom vertical	Extend	1500	1900	18±2	13±2
	Retract	1500	1950	11±2	11±2
Jib boom	Raise	1500	650	23±3	23±3
	Lower	1500	500	17±3	17±3
Rotary joint	Left	1500	500	20±5	20±5
	Right	1500	500	20±5	20±5
Slew 90 deg from forward position	Stow - slew left	1500	920	20±4	20±4
	Stow - slew right	1500	920	20±4	20±4
	Raised - slew left	1500	920	32±6	32±6
	Raised - slew right	1500	920	32±6	32±6
Leveling	Leveling up	1500		58±12	58±12
	Leveling down	1500		45±12	45±12
Steer	Left		2500	NA	3±1
Steer right	Right		2500	NA	3±1
Machine fully raised and lower as earliest as possible	Raise			100±15	86±15
	Lower			100±15	86±15
<ul style="list-style-type: none"> • Raise: Articulated boom + Main boom ->Telescopic boom -> Jib boom in last • Lower: Telescopic boom -> Articulated boom + Main boom -> Jib boom 					

Parameters		Motor RPM		Cycle time in Seconds	
		Base	Platform	Base	Platform
Machine fully raised and lower as earliest as possible	Raise			80±15	80±15
	Lower			80±15	80±15
<ul style="list-style-type: none"> • Raise: Main boom + Jib boom -> Articulated boom -> Telescopic boom in last • Lower: Telescopic boom - > Articulated boom -> Main boom + Jib boom 					

Table 21. Braking Distance

Test conditions	Braking distance
Stowed condition, low torque, hare mode on flat ground	2m
Stowed condition, low torque, tortoise mode on flat ground	1m
Elevated mode, low torque, hare mode on flat ground	0.1m

Boom Dimensions and Performance

Figure 97.

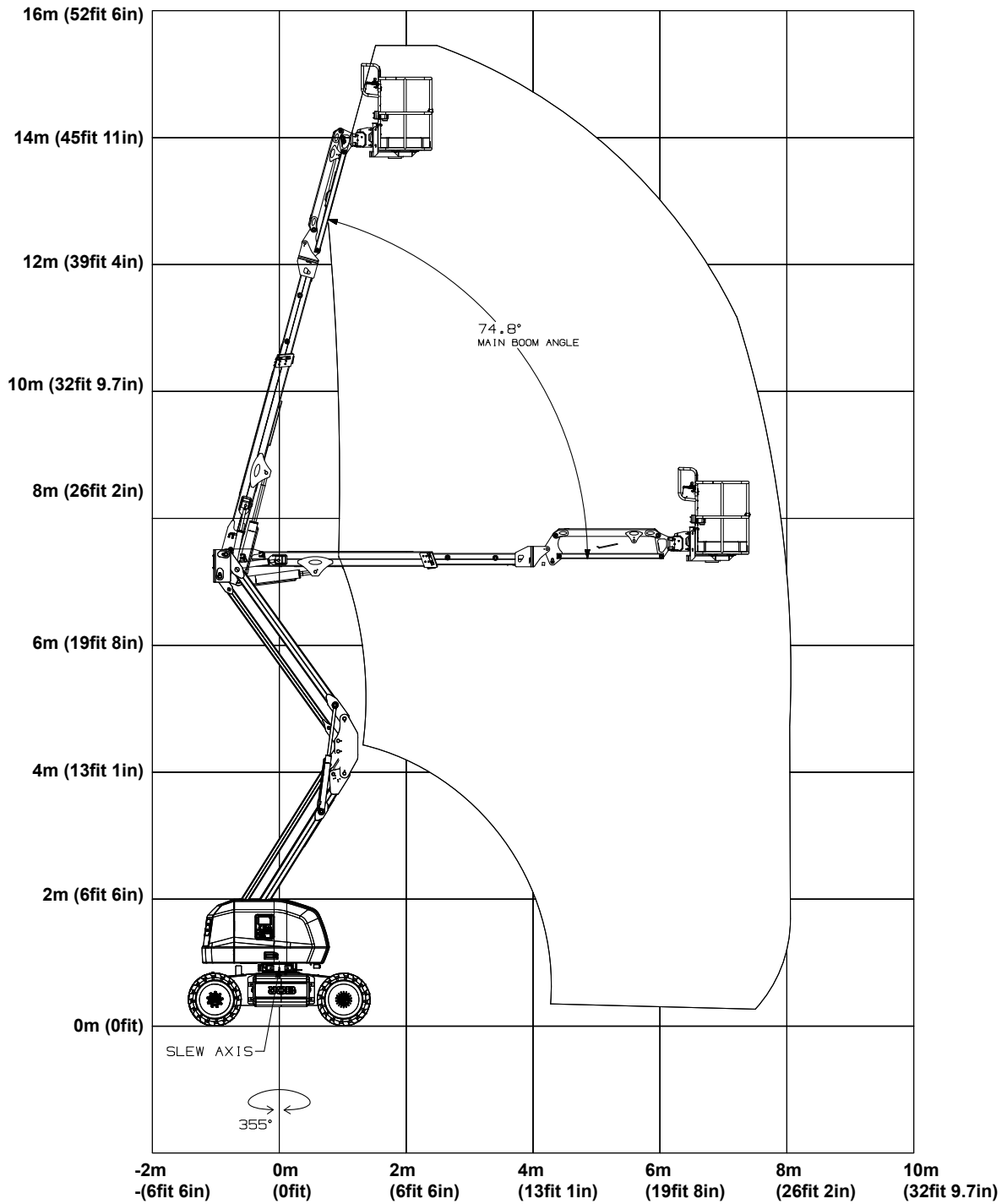

JCB © CONNOR STANMORE - 13/03/2026 07:54.



Noise Emissions

Noise Data

All Machines

Noise value does not exceed 75dB.

JCB © CONNOR STANMORE - 13/03/2026 07:54.



Vibration Emissions

Vibration Data

Whole-body vibration emission in accordance with ISO 2631-1:1997 does not exceed 0.5m/s.

Hand-arm vibration determined in accordance with dynamic test conditions defined in ISO 5349-2:2001 does not exceed 2.5m/s.

JCB © CONNOR STANMORE - 13/03/2026 07:54.

Fluids, Lubricants and Capacities

General

JCB recommend that you use the JCB lubricants shown as they have been verified by JCB for use on JCB machines. However, you could use other lubricants that are equivalent to the JCB standards and quality or offer the same machine component protection.

Table 22. Fluids, Lubricants and Capacities

Item	Capacity	Fluid/Lubricant	JCB Part Number	Container Size ⁽¹⁾	Specification
	L				
Fuel Tank	40L	Diesel Oil	-		
Engine Oil (for KDW 1003)	4.2L	-20°C (-4°F) to 45°C (112.9°F) JCB Ultra performance 10W30	4001/3005	20L	API CJ4, ACEA E9
		Below -25°C (-13°F) to 30°C (86°F) JCB Ultra performance 5W30	4001/3105	20L	API CJ4, ACEA E6, E7,E9
		Below -25°C (-13°F) to 45°C (113°F) JCB Ultra performance 5W40	4001/3405	20L	API CJ4
Engine Coolant	5L	JCB Antifreeze HP / Coolant/Water	4006/1120	20L	ASTM D3306, ASTM D4985, ASTM D6210, SAE J1034, BS6580 (1992), AFNOR NF R15-601
Hydraulic System (Standard)	System 72L and Tank 55L	-12°C (10.4°F) to 46°C (114.7°F): JCB Hydraulic Fluid OP32	4002/1000	20L	VG32 Grade oil
Hydraulic System (Optional)	System 72L and Tank 55L	Max 51°C (123.7°F): JCB Hydraulic Fluid OP46	4002/3000	20L	HV46 Grade oil: Hot climate region
Slew Ring Bearings	As required	JCB HP Grease	4003/2017	0.4kg	
Slew Ring Gear Teeth	As required	JCB Special Slew Pinion Grease	4003/1619	0.4kg	
Hub Oil	0.68L	Gear Oil (slew) 80W90	4000/4500 or 4000/3400		Hot climate range: 0→51°C (32.0→123.7°F)
		JCB Advanced Gear Oil 68	4000/0404		Temperate climate range: -20→46°C (-4.0→114.7°F)
All Other Grease	As required	JCB MPL-EP Grease	4003/1501	0.4kg	

(1) For information about the different container sizes that are available (and their part numbers), contact your local JCB dealer.

Fuel

▲ WARNING Do not use petrol in this machine. Do not mix petrol with the diesel fuel. In storage tanks the petrol will form flammable vapours.

Notice: No warranty liability will be accepted for engine failures where unacceptable fuel grades (or their equivalent) have been used at any stage.

Acceptable and Unacceptable Fuels

Use the same type of diesel fuel as used in cars (EN 590 for E.U. - ASTM D975-09B regulation - S 15 for U.S). Use of other types of fuel could damage the engine. Do not use dirty diesel fuel or mixtures of diesel fuel and water since this will cause serious engine faults.

Clean fuel prevents the fuel injectors from clogging. Immediately clean up any spillage during refuelling.

Never store diesel fuel in galvanized containers (i.e. coated with zinc). Diesel fuel and the galvanized coating react chemically to each other, producing flaking that quickly clogs filters or causes fuel pump and/or injector failure.

Fuels for Low Temperatures

When operating the engine in ambient temperatures lower than 0°C (32.0°F), use suitable low temperature fuel normally available from fuel distributors and corresponding to the specifications in the table.

These fuels reduce the formation of paraffin in diesel at low temperatures.

When paraffin forms in the diesel, the fuel filter becomes blocked interrupting the flow of fuel.

Biodiesel Fuel

Fuels containing 10% methyl ester or B10, are suitable for use in this engine provided that they meet the specifications listed in the table.

Do not use vegetable oil as a biofuel for this engine.

Any failures resulting from the use of fuels other than recommended will not be warranted.

Table 23. Fuel Compatibility

	Compati-ble		Certifica-tion emis-sion		Warranty coverage		Engine waste	
	yes	no	yes	no	yes	no	yes	no
EN 590, DIN 51628 - Military NATO fuel F-54 (S=10 ppm)	○		○		○			○
No 1 Diesel (US) - ASTM D 975-09 B - Grade 1-D S 15 (S=15 ppm)	○		○		○			○
No 1 Diesel (US) - ASTM D 975-09 B - Grade 1-D S 500 (S=500 ppm)	○			○	○ ⁽¹⁾			○
No 2 Diesel (US) - ASTM D 975-09 B - Grade 2-D S 15	○		○		○			○
No 2 Diesel (US) - ASTM D 975-09 B - Grade 2-D S 1500	○			○	○ ⁽¹⁾			○
ARCTIC (EN 590/ASTM D 975-09 B)	○ ⁽²⁾		○		○			○
High sulfur fuel < 5000 ppm (<0.5%)	○			○	○ ⁽¹⁾			○ ⁽¹⁾
High sulfur fuel > 5000 ppm (<0.5%)	○			○	○ ⁽³⁾			○ ⁽³⁾
High sulfur fuel > 10000 ppm (>1%)		○		○		○	○	
Civil Jet Fuels Jet A/A1		○		○		○	○	
Civil Jet Fuels Jet B		○		○		○	○	
Bio Fuels (EN14214)	○ ⁽⁴⁾		○ ⁽⁴⁾		○ ⁽⁴⁾			○ ⁽⁴⁾

(1) Except for catalyst clogged and EGR.
 (2) Without adding oil.
 (3) Except for catalyst clogged and EGR. Shorter oil change intervals.
 (4) Max. 10% in fuel.

JCB © CONNOR STANMORE - 13/03/2026 07:54.

Coolant

▲ **WARNING** Coolant can be harmful and is restricted to professional users only. Obey the manufacturer's instructions when handling full strength or diluted coolant and always use appropriate PPE. Inappropriate coolant handling may damage fertility or the unborn child.

Notice: Check which coolant type is installed in the machine before topping up the coolant. Mixing of different coolant types is not recommended and may result in invalidation of the warranty offered by JCB. In the event of mixing or if the coolant type is to be changed, the coolant circuit should be completely drained and flushed twice with clean water before re-filling with fresh coolant.

Check the strength of the coolant mixture at least once a year, preferably at the start of the cold period.

Replace the coolant mixture according to the intervals shown in the machine's Service Schedule.

You must dilute full strength coolant with clean water before use. You must dilute full strength coolant with distilled or de-ionized water.

The correct concentration of coolant protects the engine against frost damage in winter and provides year round protection against corrosion.

Table 24.

Concentration	Level of protection
50% (Standard)	Protects against damage down to -40°C (-40°F)
60% (Extreme Conditions Only)	Protects against damage down to -56°C (-69°F)

Do not exceed a 60% concentration, as the freezing protection provided reduces beyond this point.

- Make sure that the coolant complies with specification in this manual.
- Always read and understand the manufacturer's instructions.
- Make sure that a corrosion inhibitor is included. Serious damage to the cooling system can occur if corrosion inhibitors are not used.
- Care should be taken to not mix coolant types. Mixing coolant will have a detrimental effect on the performance of the coolant.

Torque Values

Data

Table 25. Critical Torque Values

Item	Torque
Wheel lug nuts	250N·m
Rear axle capscrews - hub to chassis	250N·m
Front axle capscrews - hub to knuckle	150N·m
Setscrews - platform to carrier underside	74N·m
Pivot pin with locknut - rotary actuator	823N·m
Setscrews - rotary actuator top ring	74N·m
Slew bearing bolts (top and bottom sets)	259N·m
Counterweight bolts	621N·m

Electrical System

General

Table 26. 12V Battery

Item	Specification
Battery voltage	12V
Capacity	110Ah
CCA (Cold Cranking Amps)	900

Table 27. 48V Batteries

Battery capacity	400Ah
Battery Type	Lead acid
Battery Voltage	48V
Battery pack nominal voltage	48V
Battery Life (80% DOD (Depth of Discharge))	800 cycles
Operating temperature range	-20→60°C (-4.0→139.9°F)
8 batteries series connected output	48V

Table 28. Charger Specification

Item	Specification
IP Rating	65
Input	100→240V13A50→60Hz
Output	48VDC,68A max

Table 29. Front Drive Motor

Item	Specification
Motor Type	3 phase AC motor IPM
IP Rating	67
Power	6kW
Voltage	32V AC (Alternating Current)

Table 30. Rear Drive 2 motors

Item	Specification
Motor Type	3 phase AC induction motor
IP Rating	54
Power	3.15kW
Voltage	32V AC

Table 31. Pump Motor 3 Phase - Hydraulic Drive

Item	Specification
Type	3 phase AC motor IPM
IP Rating	54
Power	9.1kW
Voltage	32V AC

Fuses

Primary Fuses

Table 32.

Fuse	Rating
Main primary fuse	80A
Electric motor primary fuse	200A

Base Control Fuses

Figure 98.

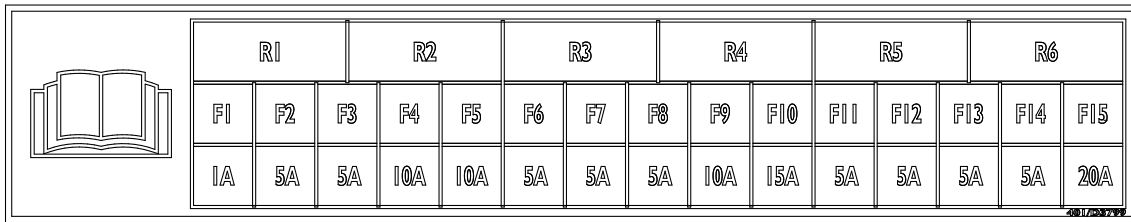

Table 33.

Fuse ID	Fuse	Rating
F1	Ignition fuse	1A
F2	Base E-stop, horn relay, bosch ECU (Electronic Control Unit) and diagnostic connector	5A
F3	Bosch ECU base	5A
F4	Platform weight sensor and tilt sensor	10A
F5	Display and axle lock pressure sensor	10A
F6	Bosch ECU platform supply	5A
F7	Bosch ECU platform supply	5A
F8	Bosch ECU base supply	5A
F9	Spare	10A
F10	Engine ignition relay	15A
F11	Worklight (optional)	5A
F12	Customer telematics, livelink ECU and bosch ECU	5A
F13	Livelink	5A
F14	Display	5A
F15	Spare	20A

Busbar Fuses

Figure 99.

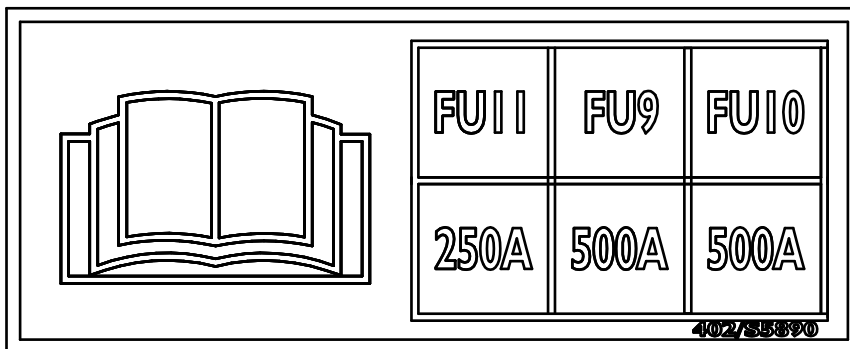

Table 34.

Fuse ID	Fuse	Rating
FU9	Front motor inverter contactor	500A
FU10	Rear motor inverter contactor	500A
FU11	Pump inverter contactor	250A

Harness Fuses

Figure 100.

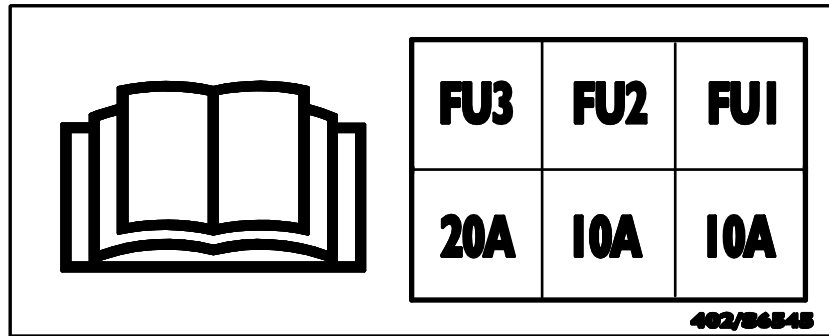

Table 35.

Fuse ID	Fuse	Rating
FU1	To chassis ground	10A
FU2	Inverter or recharge relay	10A
FU3	DC-DC converter	20A

Platform Control Fuse

Figure 101.

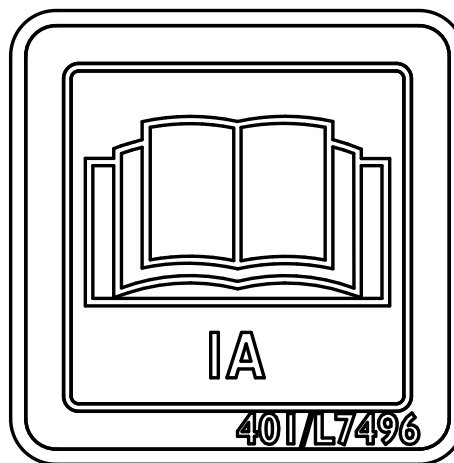

Table 36.

Fuse ID	Fuse	Rating
F1	Ignition feed fuse	1A

Relays

Primary Relays

Table 37.

Description	Rating
Electric pump relay	150A

Base Control Relays

Figure 102.

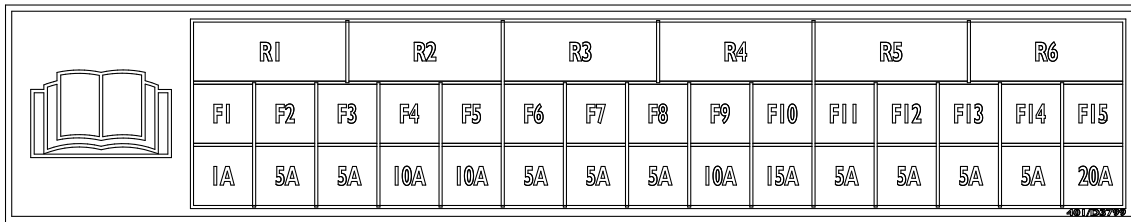

Table 38.

Relay ID	Description	Rating
R1	Ignition relay 1	10.5A
R2	Ignition relay 2	10.5A
R3	Ignition relay 3	20A
R4	Ignition relay 4	20A
R5	D+ relay	20A
R6	Horn relay	20A

Harness Relays

Figure 103.

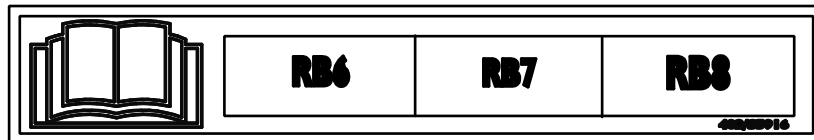

Table 39.

Relay ID	Description	Rating
RB6	Precharge relay	40A
RB7	FR/RR inverter relay	20A
RB8	DC-DC converter relay	20A

Platform Control Relay

Table 40.

Relay ID	Description	Rating
R1	Platform buzzer relay	40A

Engine

Data

Table 41.

Description	Data
Engine Type	Kolher KDW 1003
Emission stage	EPA Tier 4 final / ST-V
Alternator capacity	45A
Type	Mechanical
Number of cylinders	3
Engine capacity	1028.5 cm ³
Rated power	14.8kW @ 3000 RPM (Revolutions Per Minute)
Rated torque	50N·m @ 2200 RPM
High idle speed	3000
Low idle speed	3000 (Engine starts at full throttle)

Hydraulic System

General

Table 42.

Description	A45E
Hydraulic tank volume	55L
Hydraulic system pressure	210bar (3,045.8psi)

Wheels and Tyres

General

Table 43.

Tyre Size	Type	Make	Tyre Width	Tyre Outer Diameter	Additional Counter-weight	Category	Remark
33X12D610 (NM)	Foam filled - non-marking	Blacksmith	305mm	838mm	130kg	Standard	130kg will be company fitted.
33X12-20/7.5 (SR02H) solid	Solid marking	Zhongce Rubber	305mm	835mm	130kg	Option	130kg will be company fitted.
33X12D610 (Litefoot)	Turf - foam filled marking	Blacksmith	296mm	838mm	210kg	Option	Remove 130kg counterweight and assemble 210kg in place of it.

Fault-Finding

General

Fault code information of the machine is available in help files via servicemaster and service pro.
Refer to: servicepro.jcb.com.



Declaration of Conformity

General

A completed copy of the EC/UKCA Declaration of Conformity is supplied with all machines manufactured according to EC type examination and/or self-certification requirements.

A sample copy of the EC/UKCA Declaration of Conformity and a summary of the information that can appear is provided.

[Refer to: Data \(Page 168\).](#)

Data

Table 44.

A	Name and Address of the Manufacturer
B	Mobile Elevating Work Platform (Access Platform)
C	Model Name
D	Serial Number
E	EN280-1:2022
F	Managing Director, JCB Vibromax GMBH, Europaallee 113a, 50226 Frechen, Germany.
G	TÜV NORD CERT GmbH Am TÜV 1, 45307 Essen, Germany.
H	TUV UK Limited AMP House, Suites 27 – 29, Fifth Floor, Dingwall Road, Croydon, CR0 2LX, United Kingdom
J	Rocester
K	Date of Declaration
L	Engineering Manager

JCB © CONNOR STANMORE - 13/03/2026 07:54.

Figure 104.

<h2 style="margin: 0;">Declaration of Conformity</h2>		
NAME AND ADDRESS OF MANUFACTURER	<div style="border: 1px solid black; height: 60px; width: 100%;"></div>	A
HEREBY DECLARES THAT THE MACHINERY / EQUIPMENT DESCRIBED BELOW COMPLIES WITH ALL UK AND EU RULES AS APPLICABLE :	<input style="width: 100%;" type="text"/>	B
DESCRIPTION OF MACHINERY / EQUIPMENT	<input style="width: 100%;" type="text"/>	
TRADE NAME:	<input style="width: 100%;" type="text"/>	
MODEL NAME	<input style="width: 100%;" type="text"/>	C
SERIAL NUMBER OF MACHINERY / EQUIPMENT	<input style="width: 100%;" type="text"/>	D
COMPLIES WITH THE PROVISIONS OF THE MACHINERY DIRECTIVE 2006/42/EC [AS AMENDED] AND THE SUPPLY OF MACHINERY (SAFETY) REGULATIONS 2008 [AS AMENDED] 2008 No. 1597 THE SUPPLY OF MACHINERY (SAFETY) REGULATIONS 2008 THE FOLLOWING STANDARDS HAVE BEEN USED		
	<input style="width: 100%;" type="text"/>	E
NAME AND ADDRESS OF PERSON ESTABLISHED IN THE EU AUTHORISE D TO COMPILE THE TECHNICAL CONSTRUCTION FILE FOR UK REFER TO ADDRESS ABOVE AND SIGNATORY	<div style="border: 1px solid black; height: 60px; width: 100%;"></div>	F
COMPLIES WITH THE PROVISIONS OF THE ELECTRO-MAGNETIC COMPATABILITY DIRECTIVE 2014/30/EU [AS AMENDED] ELECTROMAGNETIC COMPATIBILITY REGULATIONS 2016 [AS AMENDED]		
NAME AND ADDRESS OF NOTIFIED BODY:	<div style="border: 1px solid black; height: 30px; width: 100%;"></div>	G
CERTIFICATE NUMBER:	<input style="width: 100%;" type="text"/>	
NAME AND ADDRESS OF CONFORMITY ASSESSMENT BODY	<div style="border: 1px solid black; height: 30px; width: 100%;"></div>	H
CERTIFICATE NUMBER:	<input style="width: 100%;" type="text"/>	
PLACE OF DECLARATION	<input style="width: 100%;" type="text"/>	J
DATE OF DECLARATION	<input style="width: 100%;" type="text"/>	K
NAME OF AUTHORISED SIGNATORY	<input style="width: 100%;" type="text"/>	
POSITION	<input style="width: 100%;" type="text"/>	L
SIGNATURE	<div style="border: 1px solid black; height: 20px; width: 100%;"></div>	

JCB © CONNOR STANMORE - 13/03/2026 07:54.

Warranty Information

Service Record Sheet

Table 45.

	Signature and stamp		Date
	Annual Insurance (Yes)		Hours

Figure 105. Installation Checklist

			/ /		h

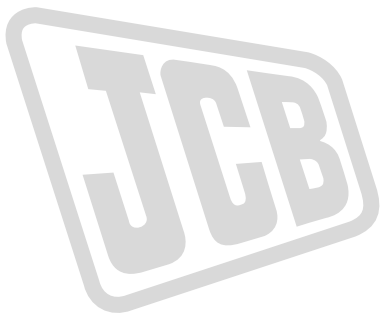

Figure 106. 1st 100h/1 Month

			/ /		h

Figure 107. 500h/6 Month

			/ /		h

Figure 108. 1000h/12 Month

 	 1 / /	 h



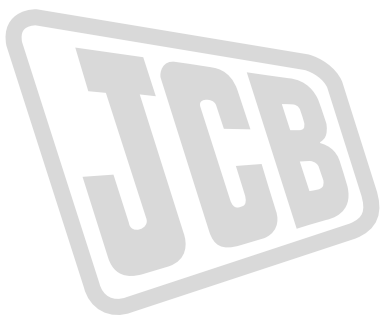

		

Figure 109. 1500h/18 Month

 	 1 / /	 h



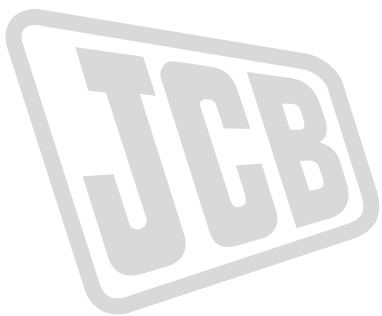

		

Figure 110. 2000h/24 Month

 	 1 / /	 h



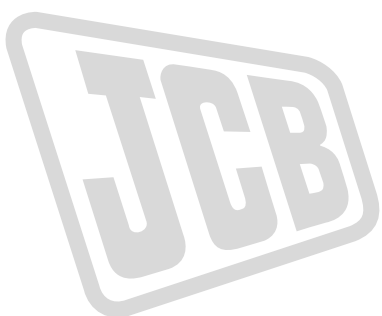

		

Figure 111. 2500h/30 Month

 	 1 / /	 h



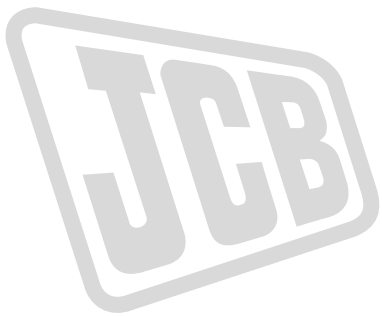

		

Figure 112. 3000h/36 Month

 	 1 / /	 h



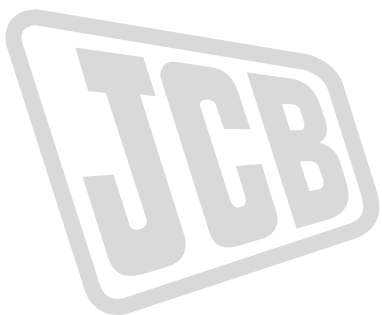

		

Figure 113. 3500h/42 Month

 	 1 / /	 h



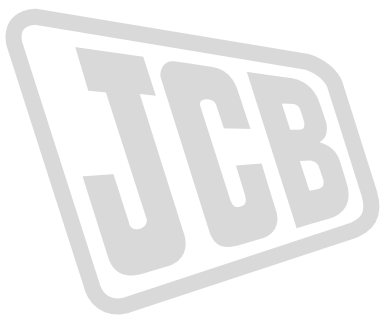

		

Figure 114. 4000h/48 Month

 	 1 / /	 h



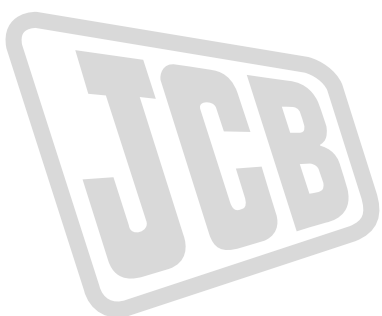

		

Figure 115. 4500h/54 Month

 	 1 / /	 h

		

Figure 116. 5000h/60Month



 	 1 / /  h

Figure 117. 5500h/66 Month

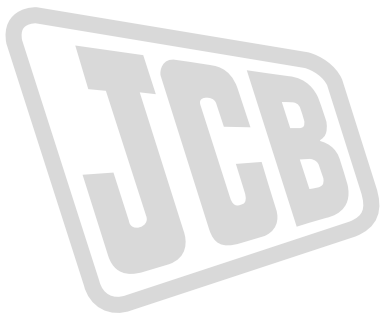

 	 1 / /  h

Figure 118. 6000h/72 Month

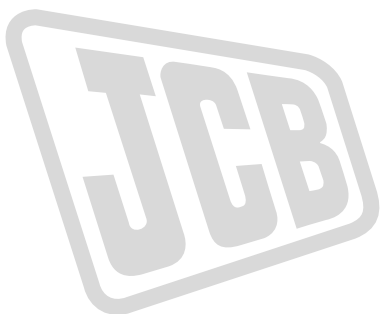

 	 1 / /  h

Figure 119. 6500h/78 Month





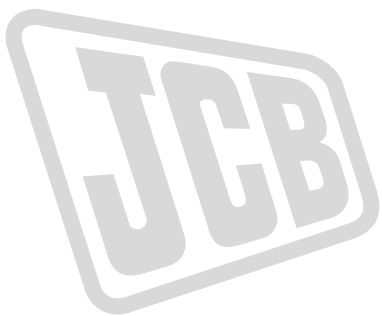

 	 1 / /  h

Figure 120. 7000h/84 Month

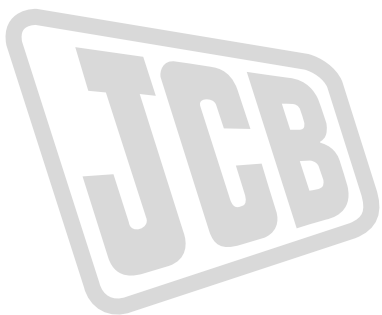
 	 1 / /	 h



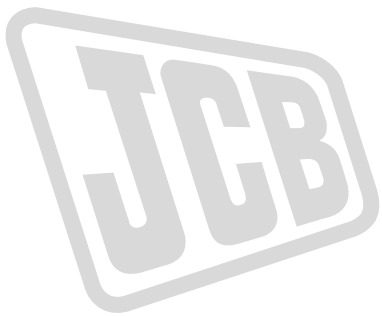
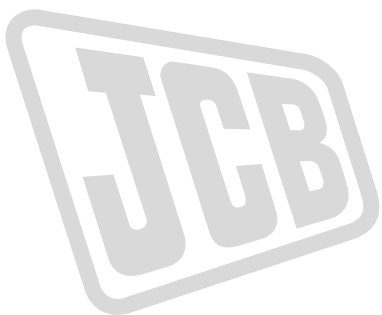

		

Figure 121. 7500h/90 Month

 	 1 / /	 h



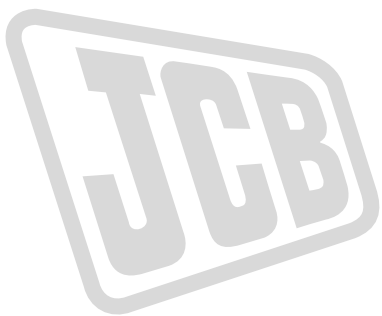

		

Figure 122. 8000h/96 Month

 	 1 / /	 h



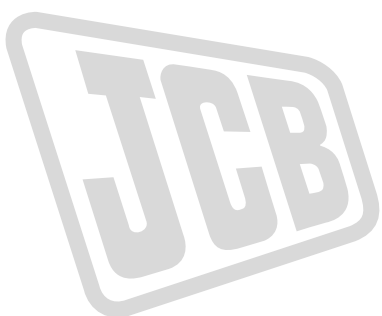

		

Figure 123. 8500h/102 Month

 	 1 / /	 h



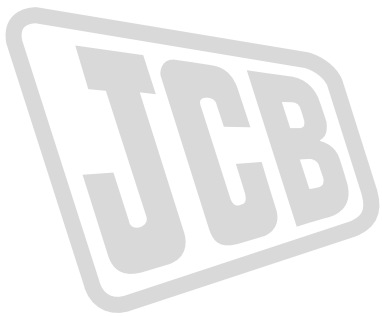

		

Figure 124. 9000h/108 Month

 	 1 / /	 h



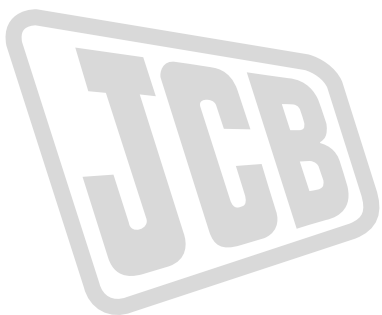

		

Figure 125. 9500h/114 Month

 	 1 / /	 h



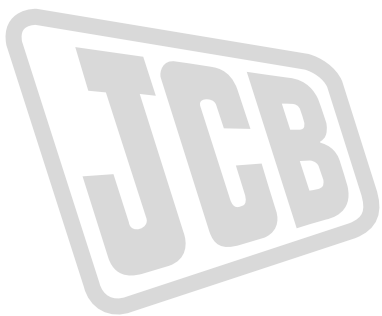

		

Figure 126. 10000h/120 Month

 	 1 / /	 h



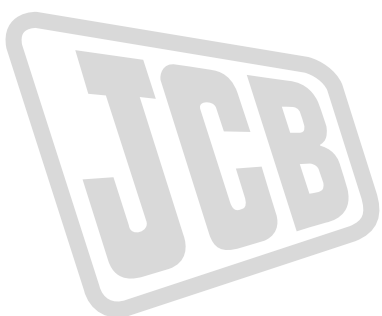

		

Figure 127. 10500h/126 Month

 	 1 / /	 h