



3TS-8T 3.2

QUICK REFERENCE GUIDE

This Quick Reference Guide DOES NOT replace the Operators Manual. You MUST read ALL the disclaimers and safety and other instructions in the Operators Manual before initially operating this product. Accordingly, no legal claims can be entertained based on the data, illustrations or descriptions in this Quick Reference Guide.

Static Dimensions

		Retracted	Extended Boom
A	Overall length	ft-in (m) 12-5 (3.8)	16-1 (4.9)
B	Wheelbase	ft-in (m) 6-11 (2.1)	
C	Angle of departure	degrees 29	
D	Overall height	ft-in (m) 6-11 (2.1)	
E	Dump height	ft-in (m) 7-10 (2.4)	10.8 (3.2)
Ea	Crowd height	ft-in (m) 13-5 (4.1)	18-4 (5.0)
F	Loadover height	ft-in (m) 9-6 (2.9)	12-5 (3.8)
G	Height to hinge pin fully raised	ft-in (m) 10-6 (3.2)	13-3 (4.03)
H	Reach	ft-in (m) 3-6 (1.1)	7-4 (2.25)
I	Max. reach @ full height	ft-in (m) 3-3.3 (1)	5-7 (1.7)
J	Reach @ full height - fully dumped	ft-in (m) 2-3 (0.7)	4-3 (1.3)
K	Dig depth - toe plate horizontal clearance	in (mm) 0.35 (9)	11.7 (294)
Ka	Dig depth - toe plate vertical clearance	in (mm) 32.4 (825)	43.3 (1,101)
L	Rollback @ ground	degrees 30	
M	Dump angle	degrees 42	
Ma	Max. rollback angle	degrees 94	
N	Bucket width - standard	ft-in (m) 6-1 (1.85)	
O	Width over tires - standard	ft-in (m) 6-5 (2.0)	
P	Length without attachment	ft-in (m) 9-11 (3.02)	
Q	Ground clearance	in (mm) 9.4 (238)	
	Rated operating capacity 35%	lb (kg) 3,695 (1,676)	1,600 (725)
	Rated operating capacity 50%	lb (kg)	
	Bucket capacity - standard	yd ³ (m ³) 0.56 (0.43)	

Cab and Switch Panel

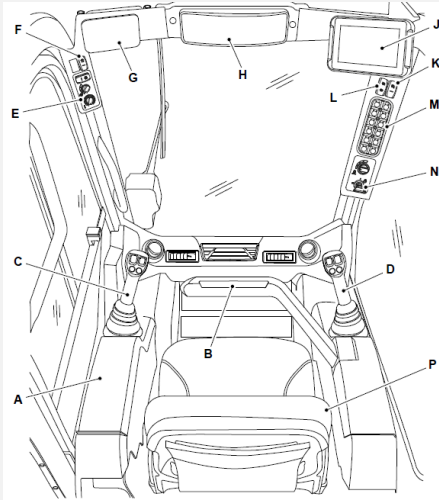

- A Left armrest (contains 12V accessory socket)
- B Right interlock bar
- C Left joystick control lever
- D Right joystick control Lever
- E Cab HVAC (Heating Ventilation Air Conditioning)
- F Beacon
- G Radio
- H Interior mirror
- J Colour display
- K Auto stop
- L Exhaust regeneration inhibit
- M Console switches
- N Ignition switch
- P Operator seat

Tie Down Points

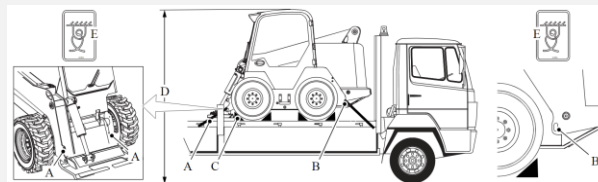

- A. Front tie down points
- B. Rear tie down points
- C. Blocks
- D. Machine height
- E. Tie down point label

Only have a wheeled model for transport

Driving Controls – ISO Pattern

- A. Left Joystick Control Level
- B. Forward Drive
- C. Backward Drive
- D. Forward Left Drive
- E. Forward Right Drive
- F. Backward Left Drive
- G. Backward Right Drive
- H. Spin turn left
- J. Spin turn right

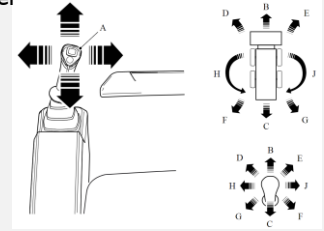

Driving Controls – H Pattern

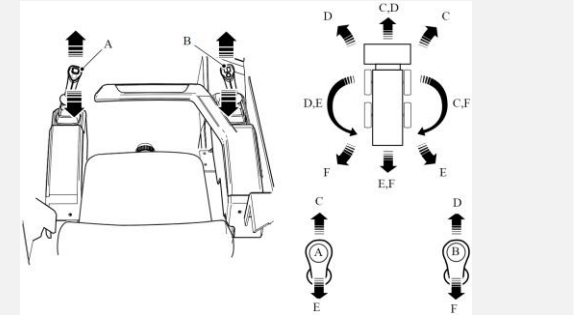

- A. Left Joystick Control Lever
- B. Right Joystick Control Lever
- CD. Forward drive
- C. Forward Right drive
- D. Forward left drive
- DE. Spin turn left
- CF. Spin turn right
- F. Backwards left drive
- E. Backwards right drive
- EF. Backwards drive

Start Up Sequence

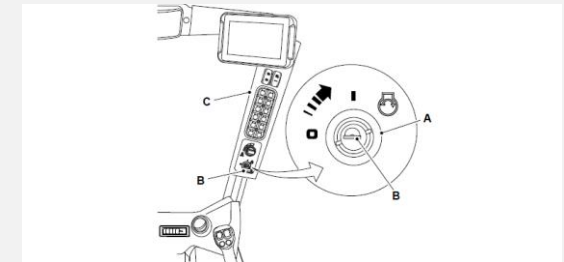

1. Buckle seatbelt
 2. Lower left arm
 3. Lower interlock bar
 4. Insert key and turn to position "1"
 5. Disengage parking brake
- A. Ignition switch
 - B. Ignition Key
 - C. Right hand console (Parking break)

Access additional information

www.servicepro.jcb.com



Instrument Panel

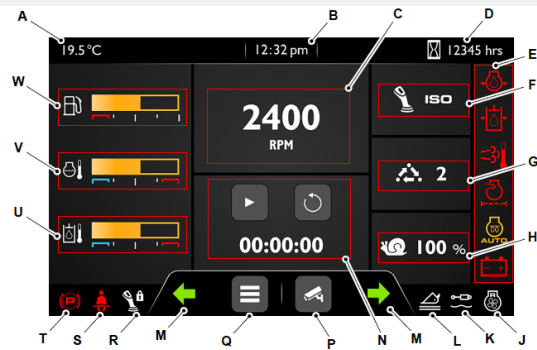

- | | |
|-----------------------------|-------------------------------|
| A. Outside temperature | N. Timer |
| B. Time | P. Camera |
| C. Engine speed | Q. Main menu |
| D. Hour meter | R. Joystick isolate |
| E. Dynamic telltale | S. Seatbelt status |
| F. Joystick ISO/H selection | T. Park brake |
| G. Mode select | U. Hydraulic oil temperature |
| H. Creep (snail) | V. Engine coolant temperature |
| J. Reverse fan | W. W Fuel level indicator |
| K. Aux unlock | |
| L. Parallel lift | |
| M. Direction indicators | |

Switch Panel

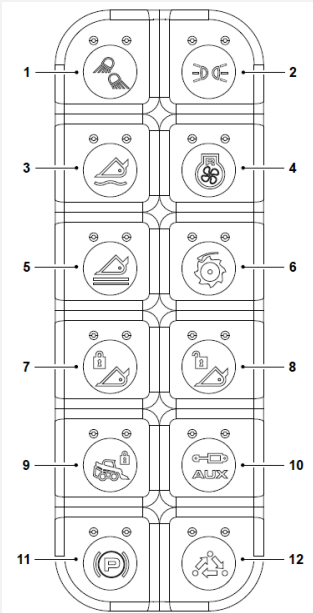

1. Front/Rear Work Lights
2. Side Lights
3. SRS (Smooth Ride System)
4. Reverse Fan (Option)
5. Parallel Lift
6. High Flow (Option)
7. Lock Quickhitch Bucket
8. Unlock Quickhitch Bucket
9. Loader Lock
10. Aux Unlock
11. Park Break
12. Mode Select

Lift Arm Controls

ISO Pattern

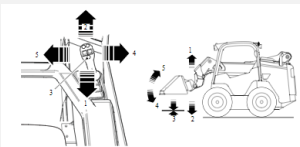

1. Lift arm raise
2. Lift arm lower
3. Float
4. Shovel dump
5. Shovel crowd

H-Pattern (option)

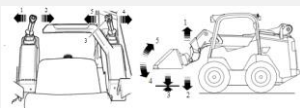

1. Lift arm raise
2. Lift arm lower
3. Float
4. Shovel dump
5. Shovel crowd

Controls – Left Joystick

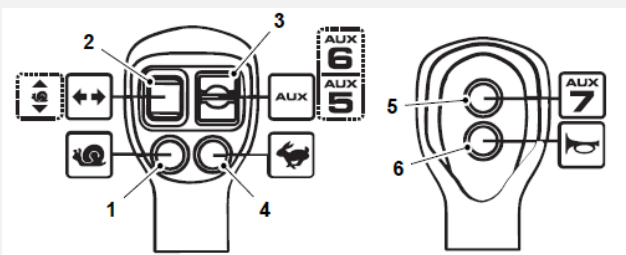

1. | Creep speed drive control (option)
2. Turn signal (option)/Creep setting (option)
3. Auxiliary proportional control switch functions : 5 and 6
4. 4 Two speed drive control (option)
5. Auxiliary control switch function : 7
6. Horn

Controls – Right Joystick

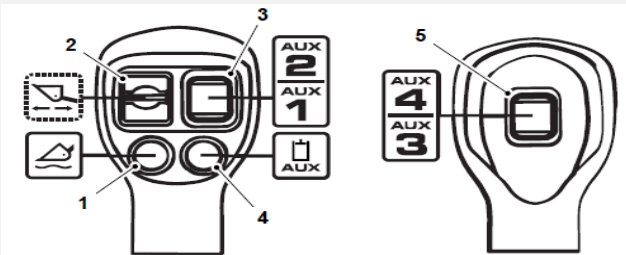

1. | Float switch (option)
2. Extend retract proportional control switch (TS ONLY)
3. Attachment first functions : 1 and 2 switch
4. Auxiliary proportional control hold switch
5. Attachment second functions : 3 and 4 switch

Auxiliary Circuit Controls

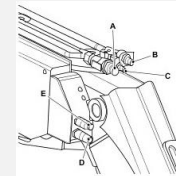

- A. Top auxiliary coupler
- B. Top auxiliary coupler
- C. Top auxiliary drain coupler
- D. Side auxiliary coupler
- E. Side auxiliary coupler

Service Points

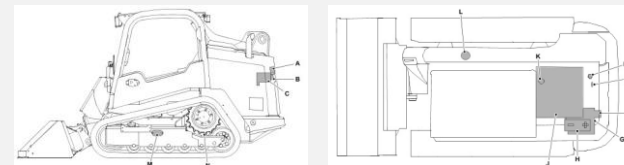

- A. Coolant expansion bottle
- B. Fuel sedimenter
- C. Air intake
- D. Engine oil filler cap
- E. Engine oil dipstick
- F. Hydraulic oil level indicator, Hydraulic oil filler cap
- G. Battery isolator
- H. Battery
- J. Radiator
- K. Radiator cap
- L. Window washer fluid bottle
- M. Track tensioner
- N. Sprocket

Access Covers

Engine Compartment Cover



- A. Handle
- B. Locking pin
- C. Locking position

- A. Locking pin
- B. Stowage position

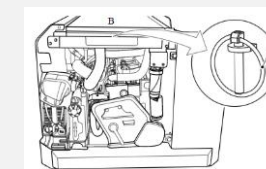

Rear Cover

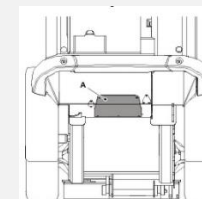

- A. Rear Cover