



RS T4F Diesel Generator
G625RS



Disclaimer

- > This Quick Reference Guide is to provide quick and simple information to the Operator and does not include any health and safety aspects. In addition, because of our continual development of machines, features described in this Quick Reference Guide may differ from those on your machine. No errors and emissions be entirely ruled out.
- > This Quick Reference Guide DOES NOT replace the Operators Manual. You MUST read ALL the disclaimers and safety and other instructions in the Operators Manual before initially operating this product. Accordingly, no legal claims can be entertained on the basis of the data, illustrations or descriptions in this Quick Reference Guide.
- > This machine should not be operated by any person who isn't appropriately qualified or had the appropriate training.
- > Operation of this machine without periodic maintenance could cause it to malfunction.
- > For more information please contact your JCB Dealer.

Index

Disclaimer	2
Dimensions & volumes.....	4
Key components.....	5
General checks.....	9
Control panel	12
Battery isolator	19
Multi voltage selection	20
Fuel connections.....	21
Positioning.....	22
Lifting	23
Emergency stops	24
Maintenance schedule.....	25
Service checks	26
Your notes.....	29

Dimensions and volumes

Model	G625RS
3 Phase – 480V – kW (prime power)	500
3 Phase – 480V – A	753
3 Phase – 208V – kW	500
Single phase – 240V – kW	300
Dimensions – inches (LxWxH)	195 x 81 x 104
Weight (operating) – lbs	21772
Dimensions (with trailer) - inches (LxWxH)	256 x 104 x 122
Weight (operating) with trailer – lbs	24752
Aftertreatment	SCR
Fuel tank capacity – US gallon	593
Fuel consumption @ 75% PRP – US gallon	24.2
Fuel autonomy – hours	24.5
DEF tank capacity – US gallon	42.3
DEF consumption @75% PRP – US gallon	1.62
DEF autonomy– hours	26.1
Noise level (23ft @ 75% load)	77

Fuel – EN590 Diesel fuel types - Auto/C0/C1/C2/C3/C4 BS2869 Class A2

Lube Oil – API CH4-SAE 10W40

Coolant – ASTM D6210

* wet weight without fuel

Key components – enclosure

Fig 1

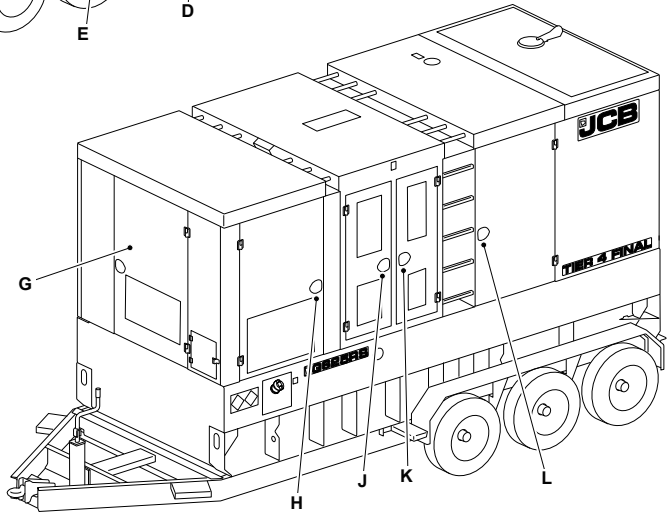
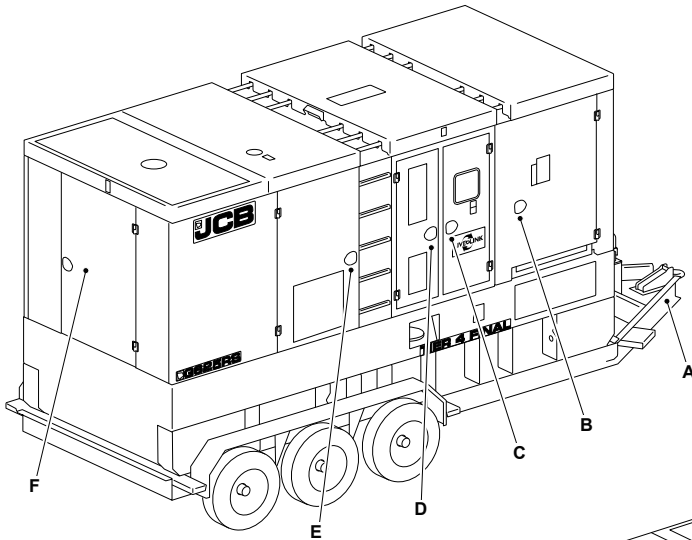

- A** Trailer
- B** Right front door
- C** Right centre front door
- D** Right centre rear door
- E** Rear right door
- F** Rear door
- G** Front door
- H** Left front door
- J** Left centre front door
- K** Left centre rear door
- L** Left rear door

Key components – generator

Fig 2

- A Exhaust system
- B Engine
- C Skid
- D Control panel
- E Camlock connections
- F Power cables exit
- G Breaker box

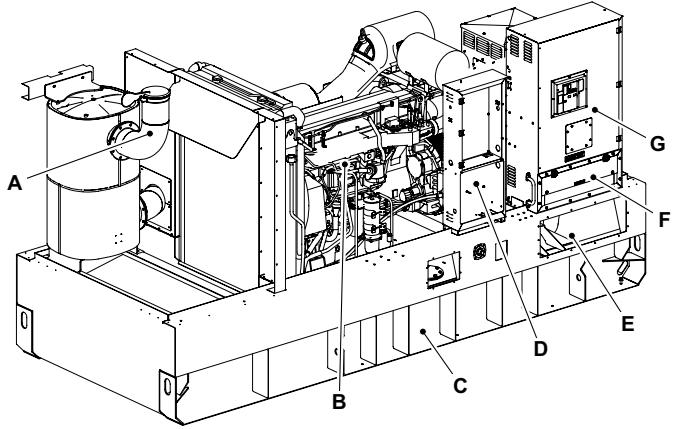

- A Bulkhead
- B Radiator
- C Battery
- D Alternator
- E Fuel tank filler
- F DEF (Diesel Exhaust Fluid) tank filler
- G Voltage control rotary switch
- H Air filter
- J SCR (Selective Catalytic Reduction)

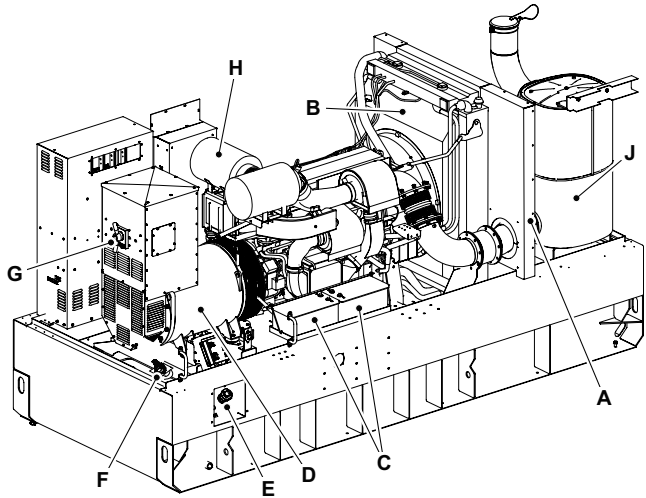

Key components – engine

Fig 3

- A** Coolant filler
- B** Expansion tank
- C** High-pressure turbo charger
- D** Air filter
- E** Air filter indicator
- F** Low-pressure turbo charger
- G** Charge air cooler (low pressure turbo)
- H** Oil sump
- J** Radiator

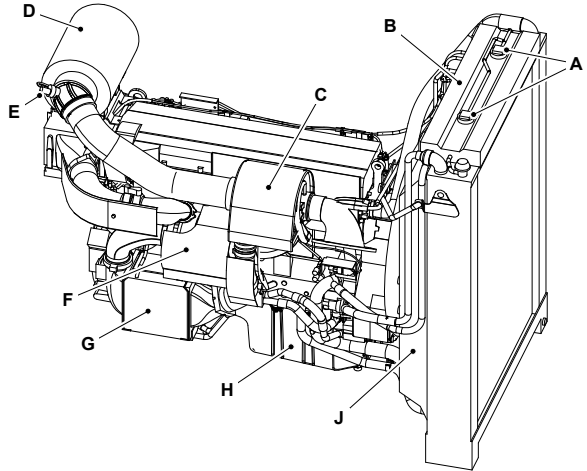

- A** Engine oil filler
- B** Fuel pre-filter
- C** Fuel filter
- D** Crankcase ventilation
- E** Oil drain pump
- F** Flywheel housing
- G** Charge air cooler (high pressure turbo)
- H** EMS (Electronic Monitoring System)
- J** Main fuel filter

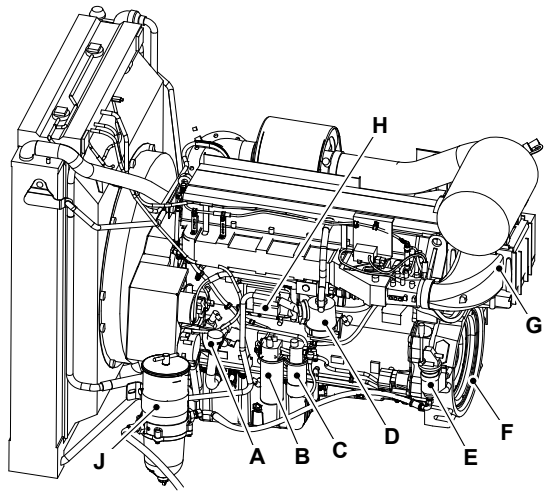

Key components – control panel

Fig 4

- A** Auxiliary indicator lamps
- B** Audible alarm
- C** BUS live indicator
- D** Audible alarm
- E** Lockable door
- F** Coolant heater and battery charger sockets
- G** GFCI 120V Small power
- H** USB (Universal Serial Bus) port
- J** Voltage alarm
- K** End of line synch switches
- L** Digital synch connections
- M** Analogue loadshare connection point
- N** 3x50A Shore power – 120V/240V

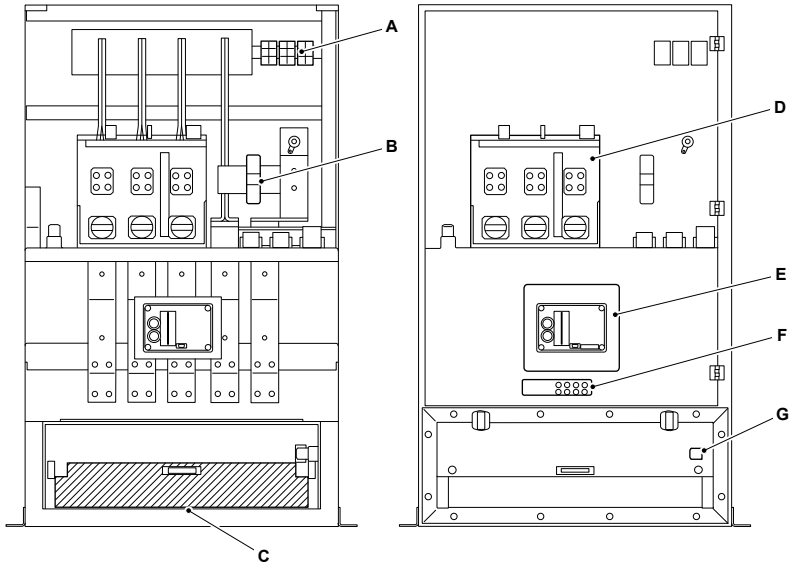
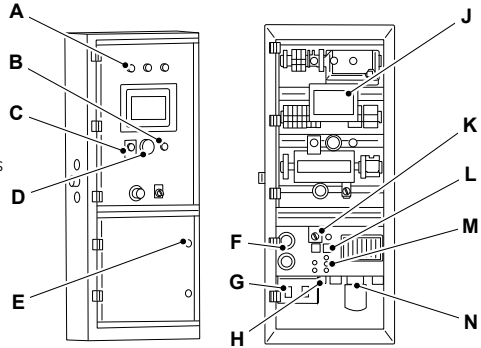

- A** DIN rail terminal
- B** Toroid
- C** Self latching cable cover with padlock
- D** Automatic circuit breaker

General checks

Before Starting the Engine

After correct installation of the unit and the wiring, the generating set must be fully checked over before first starting can be attempted. Points to check include:

- > Make sure that the battery isolator is at 'off' position before carrying out any checks.
- > Check all belts, guards and panel covers are firmly secured.
- > Check the installed wiring to ensure all connections are firmly installed in the correct position, and that wires are in good condition.
- > Make sure that the battery connections are secure and polarity of connections are correct.
- > Ensure that there is fuel in the fuel tank. Check the DEF (Diesel Exhaust Fluid). The system will only check DEF level at key on.
- > If the machine has not been run previously, if it has run out of fuel or if the fuel supply has been reconnected then the fuel system must be primed prior to starting. Check for fuel leaks during this process.
- > Check level of coolant in machine radiator, and top-up if low.
- > Check hoses for damage or loose clamps.
- > Check level of engine oil using dipstick.

Fig 5

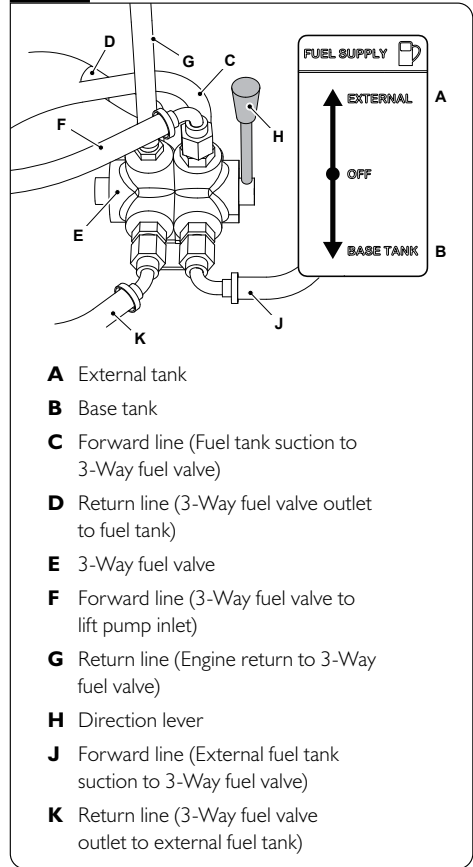

- > Check fuel filter/water separator for presence of water or contaminants.
- > Check the position of the 3-way valve to correct fuel source. Do not run the generator with the 3-way valve set to the 'off' position.
- > Visually inspect the engine and alternator for any signs of damage, water, oil or fuel leaks.

General checks

- > Make sure that all supplied documents are kept in the document holder case.
- > Ensure that machine intake and outlet air vents and grills are not obstructed or blocked in any way to allow good airflow through the machine.
- > Check that the engine intake air filter is correctly fitted, and that there are no obstructions to the incoming air.
- > Make sure that all the engine access doors are closed and secured.
- > With the exception of emergency power generators, the engine should be warmed up with a reduced load before applying the full load.
- > Check the multi-voltage section switch and configuration of breakers for your application.

General checks

Multi-voltage Selection

IMPORTANT NOTE: Operation of the rotary switch must only be carried out with the generator in stop mode and electrically isolated to prevent personal injury and damage to the equipment. Changes to the alternator voltage must be completed by a suitably trained and competent person. Please refer to the operator manual for detailed instructions including breaker protection settings.

NOTICE: A padlock must be installed to prevent accidental rotation of the multi voltage switch whilst the generator is running, otherwise damage will be caused to the alternator.

Checks after running

Ensure that the electrical load is switched off before stopping the engine.

- > Check that battery isolator is in the 'off' position.
- > Fill the fuel and DEF tanks. Make sure that the filler caps and the area round the filler openings are clean to avoid contamination of the fuel and DEF.
- > Make sure that all the engine access doors are closed and secured.
- > Check the condition of the cooling system antifreeze.
- > If necessary, prepare for the next start by connecting the cold climate equipment.

Coolant should be topped up when the engine is stopped. Make sure that enough time is allowed for the engine/coolant to cool before the radiator cap is removed.

Fig 6

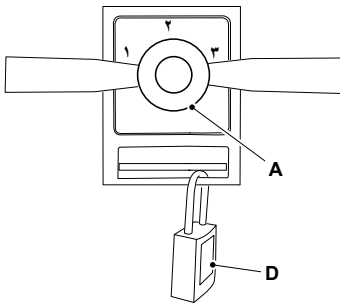

- A** Voltage control rotary switch
- 1** 480/277V Three Phase
- 2** 208/120V Three Phase
- 3** 240/120V Single Phase
- D** Padlock

Control panel – DEIF TDU107

Fig 7

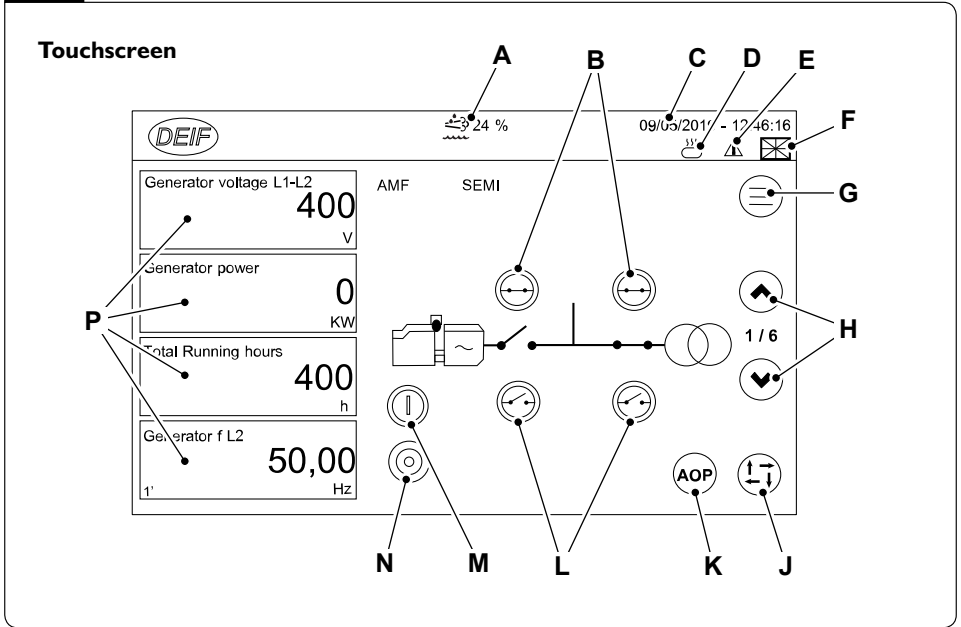

	Item	Function
A	DEF (Diesel Exhaust Fluid) percentage	Shows the percentage of DEF
B	Breaker Control	Closes the breaker
C	Date and Time	Shows the controller data and time
D	EAT (Exhaust After Treatment) dashboard	Opens EAT dashboard (shortcut)
E	Alarm	Opens Alarms (shortcut)
F	Language	Opens Language (shortcut)
G	Menu	Opens the Menu page
H	Scroll Page	Scroll up or down
J	Mode Change	Manual/Semi/Auto/Test modes

	Item	Function
K	AOP	Opens Additional Operator Panel (shortcut)
L	Breaker Control	Opens Breaker
M	Generator Control	Starts Generator
N	Generator Control	Stops Generator
P	Instrument Values	Shows instrument values

Control panel – DEIF TDU107

Operation – Manual Mode

Starting Procedure

Perform all the pre-start checks before starting the generator.

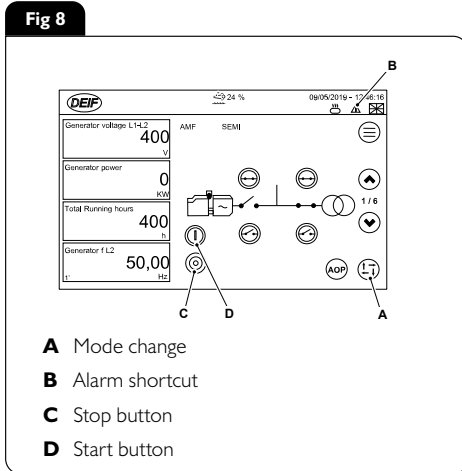

1. Turn the battery isolator to the 'on' position. Controller will power up.
2. Use the alarm shortcut to reset any alarms that may be displayed on the controller. Check for any standing alarms and investigate as necessary before proceeding with start.
3. The machine can be run in manual or semi auto dependent on the application. For remote start function the controller must be set to semi auto mode by pressing the mode change button.
4. Press the start button. The generator controller will display the start-up sequence.

5. Engine will now crank and start to run.
6. Generator will now display engine and alternator status. It will change from red to a solid green to show that it is ready with no faults.
7. Check voltage and frequency on the controller.
8. Close breaker via breaker control pushbutton.

AUTO AND LOAD SHARING OPERATION: Remote start and synchronizing multiple sets must only be set up by a suitably trained and competent person. Please refer to the operator manual for more detailed instructions.

Stand Alone Manual Mode Operation

Before Stopping

1. Check with other personnel on the job site and let them know that power is being turned off.
2. Make sure that the power shutdown will not create any hazards by turning off devices such as pumps, heaters, or lights that may need to be kept on.

Stopping Procedure

Perform the procedure below to stop the generator:

1. Turn off all loads to the generator.
2. Open the main circuit breaker. The power available lamp will go off.
3. Press the 'stop/reset' button once. The generator will stop after the specified cooling time. Duration: 5min.
4. If 'stop/reset' button is pressed again then generator will stop immediately.
5. Ready to load and generator available LED indicators will go off.
6. Turn the battery isolator to 'off' position after the engine has stopped.

Control panel – DSE 8610

Fig 9



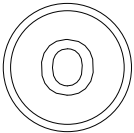
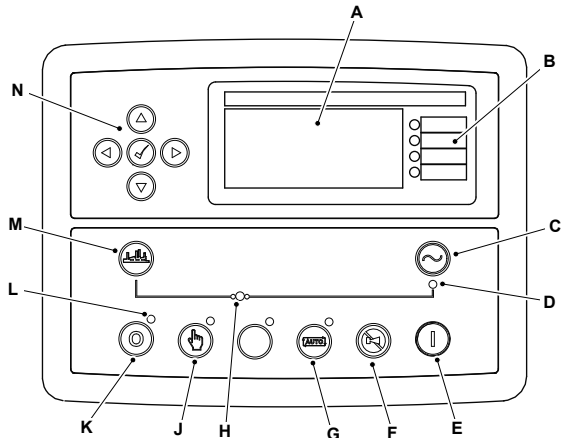

- A** Module display
- B** Four configurable status LED
- C** Close generator
- D** Generator available LED
- E** Start button
- F** Alarm mute and lamp test
- G** Auto mode
- H** Generator breaker LED
- J** Manual mode
- K** Stop/reset button
- L** Selected mode indication LED
- M** Open generator (manual mode only)
- N** Module display Menu navigation buttons



This button places the module into its STOP/RESET mode. This will clear any alarm conditions for which the triggering criteria have been removed. If the engine is running and the module is put into STOP/RESET mode, the module will automatically instruct the generator to unload ('Close Generator output' becomes inactive). In STOP/RESET mode the generator remains at rest.

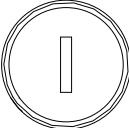
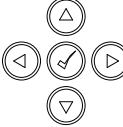

This button places the module into its MANUAL mode. Once in MANUAL mode, the module responds to the start button to start the generator and run it off load. To place the generator on load, use the 'Transfer to Generator' button. The module automatically instructs the generator to synchronise and once in sync, to be place the generator on load ('Close Generator Output' becomes active). To place the generator off load, use the 'Open Generator' button. The module automatically ramps the load off the generator and then takes it off load ('Close Generator Output' becomes inactive). Additional digital inputs are available to perform these functions. If the generator is running off-load in MANUAL mode and on load signal becomes active, the module automatically instructs the generator to synchronise and once in sync, to be place the generator on load ('Close Generator Output' becomes active). Upon removal of the on load signal, the generator remains on load until either selection of the 'STOP/RESET' mode or 'AUTO' mode.

	<p>This button places the module into its AUTO MODE. This mode allows the module to control the function of the generator automatically. The module monitors numerous start requests via digital input, PLC and MSC link and when one has been made, the set is automatically started. Once the generator is available, the module automatically instructs the generator to synchronise and once in sync, to be place the generator on load ('Close Generator Output' becomes active). Upon removal of the starting signal, the module starts the Return Delay Timer and once expired, the load is automatically ramped off the generator and then it is taken off load ('Close Generator Output' becomes inactive). The generator then continues to run for the duration of the Cooling Timer until it stops. The module then waits for the next start event.</p>
	<p>This button is only active in the STOP/RESET mode, MANUAL mode. Pressing the Start button in Stop/Reset Mode powers up the engine's ECU but does not start the engine. This can be used to check the status of the CAN communication and to prime the fuel system</p>
	<p>Used for navigating the instrumentation, event log and configuration screens.</p>
	<p>Used to silence the audible alarm in the controller, de-activates the audible alarm output (if configured) and illuminates all of the LED on the module's fascia as a lamp test function.</p>
	<p>Close Generator – The Close Generator button controls the operation of the generator load switch and is only active in the Manual Mode once the generator is available. Pressing the Close Generator button when the generator is available and off load automatically instructs the generator to synchronise and once in sync, to be place the generator on load ('Close Generator Output' becomes active). If the generator bus is dead (has not supply on it) the generator is placed on load immediately. Further presses of the Close Generator button have no effect.</p>
	<p>Open Generator – The Open Generator button is only active in the Manual Mode and allows the operator to open the generator load switch. Pressing the Open Generator button when the Generator is on load, automatically ramps the load off the generator and then takes it off load ('Close Generator Output' becomes inactive). Further presses of the Open Generator button have no effect.</p>

Control panel – DSE 8610

Operation

Single generator, controlled manually through its genset controller. Load is monitored by the operator.

Starting Procedure

Perform all the pre-start checks before starting the generator.

1. Turn on the digital controller switch.
2. Wait for few seconds, to allow the controller to power up and display to stabilise.
3. Make sure that the power on LED (Light Emitting Diode) is illuminated on earth leakage trip and there is no trip active where required.
4. Make sure that the main power supply MCCB is switched off.
5. Check that the emergency stop button is fully out, if necessary twist to reset the button.
6. Complete all pre-start, system and engine checks.
7. Press the start button and the machine will start in manual.
8. The engine will run up to speed and stabilise.
9. Check that the machine operation is correct using the screen information.
10. Make sure the power on LED is illuminated on earth leakage trip and there is no trip active.

11. Turn on the main power supply MCCB.
12. The generator can now be loaded.
13. If the earth leakage relay trips at this point consult the site electrical installation engineer.

Before Stopping

1. Check with other personnel on the job site and let them know that power is being turned off.
2. Make sure that the power shutdown will not create any hazards by turning off devices such as pumps, heaters, or lights that may need to be kept on.

Stopping Procedure

Perform the procedure below to stop the generator:

1. To stop the generator, remove any electrical loads.
2. Turn the main power supply MCCB to off position.
3. Press the stop button the generator will now stop.

AUTO AND LOAD SHARING OPERATION: Remote start and synchronizing multiple sets must only be set up by a suitably trained and competent person. Please refer to the operator manual for more detailed instructions.

Battery isolator

The battery isolator switch is used to disconnect the battery from the machine electrics. The switch must be turned to the off position if any maintenance work is to be performed on the machine.

Some machine systems perform shut down cycles after the engine stops. Wait until shut down cycles are complete before setting the battery isolator switch to the off position.

At the end of a working cycle or if the machine is being left unattended and the lights are not required, the battery must be isolated.

The control system is designed such that if the battery isolator is switched off then there is a 2min time delay to de-energise the ECU (Electronic Control Unit) to allow the DEF (Diesel Exhaust Fluid) purge to complete its shutdown cycle.

Disconnect the Machine Electrics

1. Get access to the battery isolator.
2. Turn the battery isolator key in a counter-clockwise direction and remove.

Connect the Machine Electrics:

1. Insert the battery isolator key and turn in a clockwise direction.

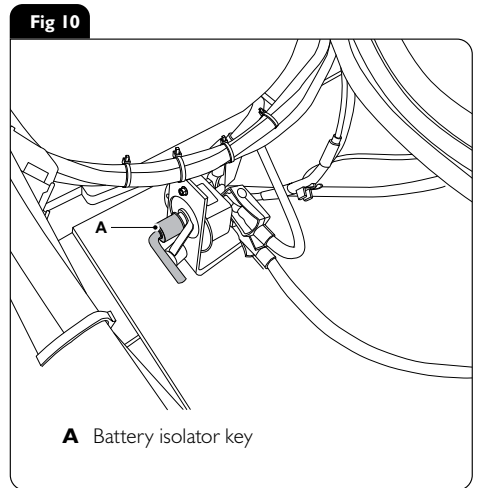

Multi voltage selection (where fitted)

Rotary Switch

3-position voltage selector switch for safe and quick break and make operation. Lockable with up to 4 separate padlocks.

Fig 11

- A** Voltage control rotary switch
- 1** 480/277V Three Phase
- 2** 208/120V Three Phase
- 3** 240/120V Single Phase
- D** Padlock

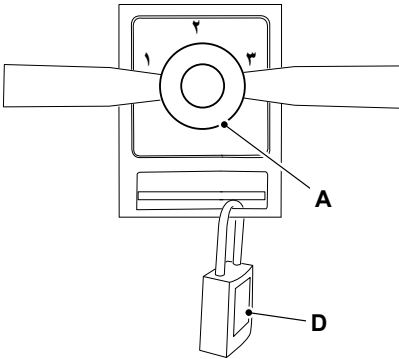

IMPORTANT NOTE: Operation of the rotary switch must only be carried out with the generator in stop mode and electrically isolated to prevent personal injury and damage to the equipment. Changes to the alternator voltage must be completed by a suitably trained and competent person. Please refer to the operator manual for detailed instructions including breaker protection settings.

NOTICE: A padlock must be installed to prevent accidental rotation of the multi voltage switch whilst the generator is running, otherwise damage will be caused to the alternator.

Fuel connections (where fitted)

Fig 12

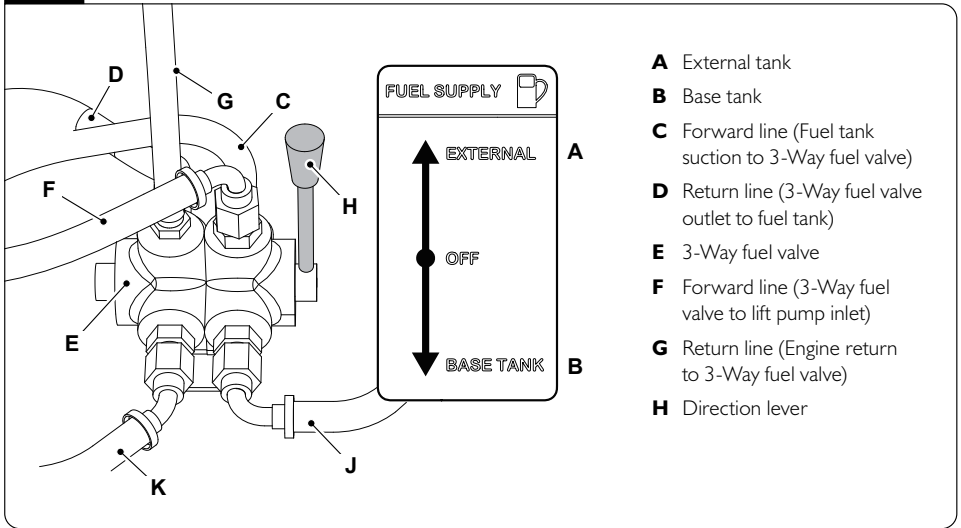

The optional 3-Way Fuel Valve allows the generator to be connected to feed and return to a remote bulk tank.

The selection lever dictates if the engine will feed from either the base tank or bulk tank. This selection lever should be fully engaged in the chosen position.

Please consult the manual for details of maximum distances and acceptable elevation of bulk fuel tanks.

Positioning

Site Installation

The generating set should be located on suitable foundations. A level concrete surface designed to carry the weight of the generating set is ideal (if unsure contact a structural engineer). All electrical and fuel ducting to and from the machine should be professionally installed. All wiring to the terminal box, and through other panels should be installed using the appropriate cable glands.

The generating set should be located to provide suitable access for regular maintenance, servicing and repair work.

Generator sets which are installed outdoors, must be located in a place which is protected against weather conditions, dust, etc. as much as possible.

For temporary installations, the generator set can rest on a well-levelled surface. For long-term installations, it is advisable to build a concrete base.

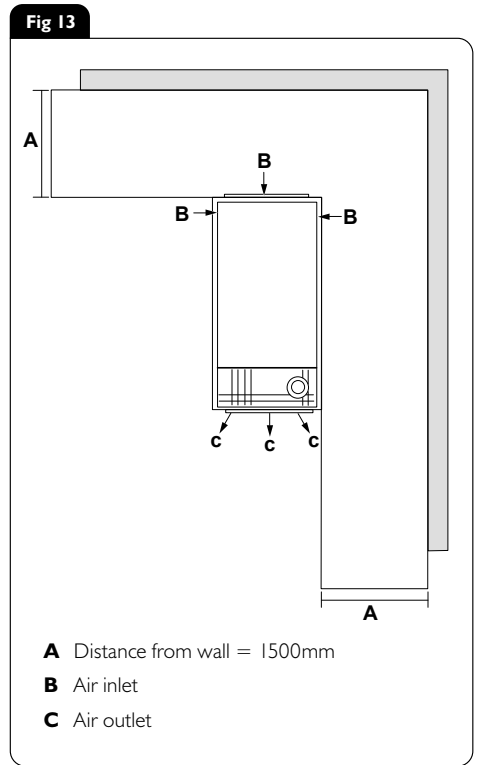

Lifting

The generating set should only be lifted using the designated lifting points or the fork pockets where provided.

Do not lift the unit by the alternator or engine lifting eyes. These are designed only to carry the weight of the specific unit (engine or alternator) and not for the weight of the fully assembled generating set.

NOTE: Always ensure that lifting equipment is rated to lift the load. Weights are shown on the generator rating plate on the side of the control panel. These weights exclude fuel, and while both the fork pockets and lifting frame are rated to allow lifting including fuel, the operator needs to ensure that they have adequate lifting capacity.

Fig 14

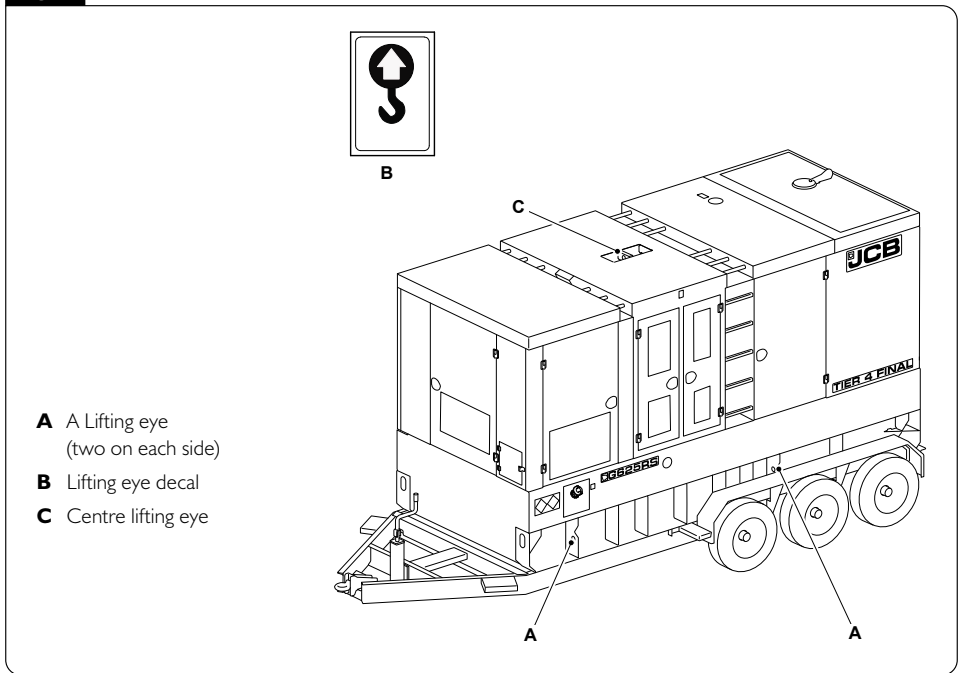

Emergency stops

A machine isolation button/emergency stop button is mounted externally on the canopy. If pressed, all machine systems will stop completely.

Use the emergency stop button in the case of an emergency or if the machine becomes unsafe and does not shutdown automatically.

NOTE: Activation of either of the emergency stop buttons will put the generator into a fault mode.

As well as manually resetting the depressed emergency stop button you will need to clear the fault from the controller.

This is normally achieved by pressing the STOP/RESET button. This can be clarified in the Control Panel section of your Operators Manual

Fig 15

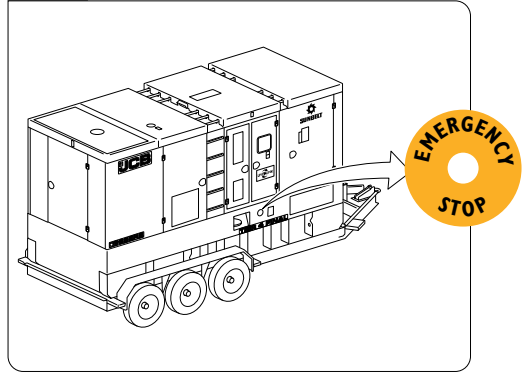

Fig 16



Maintenance schedule

Interval (h)	Calendar equivalent
10	Daily
50	Weekly
500	Six months
1000	Yearly
<input type="radio"/>	Service task can be completed by a competent operator. Details of how to complete the task are given in the operators manual.
<input type="checkbox"/>	We recommend that a service engineer completes the service task. Details of how to complete the service task are given in the service manual.

	Operation	Interval (Hours)			
		10	50	500	1000
Visual inspection	Overall visual check	<input type="radio"/>	<input type="radio"/>	<input type="checkbox"/>	<input type="checkbox"/>
Control panel	Check operation	<input type="radio"/>	<input type="radio"/>	<input type="checkbox"/>	<input type="checkbox"/>
Safety decals	Check condition		<input type="radio"/>	<input type="checkbox"/>	<input type="checkbox"/>
Emergency stop switches	Check operation		<input type="radio"/>	<input type="checkbox"/>	<input type="checkbox"/>
Earth leakage RCD & MCB	Check operation		<input type="radio"/>	<input type="checkbox"/>	<input type="checkbox"/>
External power socket box	Check condition		<input type="radio"/>	<input type="checkbox"/>	<input type="checkbox"/>
Battery terminals and voltage	Check			<input type="checkbox"/>	<input type="checkbox"/>
Control panel events history	Check			<input type="checkbox"/>	<input type="checkbox"/>
Bus bar cover safety switch	Check operation			<input type="checkbox"/>	<input type="checkbox"/>
Alternator and engine mounting bolts	Check tightness			<input type="checkbox"/>	<input type="checkbox"/>
Bus bar terminals	Check tightness			<input type="checkbox"/>	<input type="checkbox"/>
Machine earth connection	Check condition			<input type="checkbox"/>	<input type="checkbox"/>
Engine and controller harness	Check condition & connection			<input type="checkbox"/>	<input type="checkbox"/>
Coolant quality and level	Check	<input type="radio"/>	<input type="radio"/>	<input type="checkbox"/>	<input type="checkbox"/>
Oil level	Check	<input type="radio"/>	<input type="radio"/>	<input type="checkbox"/>	<input type="checkbox"/>
Water separator & fuel filter	Drain		<input type="radio"/>	<input type="checkbox"/>	<input type="checkbox"/>
Oil & filter	Change			<input type="checkbox"/>	<input type="checkbox"/>
DEF filter	Change			<input type="checkbox"/>	
Air cleaner outer element	Change				<input type="checkbox"/>
Water separator & fuel filter	Change			<input type="checkbox"/>	<input type="checkbox"/>
Engine fuel filter	Change			<input type="checkbox"/>	<input type="checkbox"/>
Front End Accessory Drive (FEAD) belt condition	Check			<input type="checkbox"/>	<input type="checkbox"/>
Engine mounting bolts for tightness	Check			<input type="checkbox"/>	<input type="checkbox"/>
All Hoses – Condition	Check			<input type="checkbox"/>	<input type="checkbox"/>
Radiator	Check			<input type="checkbox"/>	<input type="checkbox"/>
Battery terminals and voltage	Check			<input type="checkbox"/>	<input type="checkbox"/>
Generator alternator cables	Check condition			<input type="checkbox"/>	<input type="checkbox"/>
Generator alternator terminals	Check tightness			<input type="checkbox"/>	<input type="checkbox"/>

Service checks

Oil – Check (Level)

Oil is toxic. If you swallow any oil, do not induce vomiting, seek medical advice. Used engine oil contains harmful contaminants which can cause skin cancer. Do not handle used engine oil more than necessary. Always use barrier cream or wear gloves to prevent skin contact. Wash skin contaminated with oil thoroughly in warm soapy water. Do not use petrol, diesel fuel or paraffin to clean your skin.

WARNING! Never check the oil level or add oil with the engine running. Be careful of hot lubricating oil. Danger of scalding.

NOTE: Do not exceed the correct level of engine oil in the sump. If there is too much engine oil, the excess must be drained to the correct level. An excess of engine oil could cause the engine speed to increase rapidly without control.

Engine oil and oil filter change must be completed in accordance with the service schedules. Failure to change the oil and filter at the recommended interval could cause serious engine failure.

1. Stop the engine and allow it to cool.
2. Make the machine safe.
3. Wait for the oil to drain back into the engine sump before you take a reading. If not, a false low reading may be recorded which can cause the engine to be overfilled.
4. Get access to the engine.
5. Remove and clean the dipstick.
6. Replace the dipstick.
7. Remove the dipstick.
8. Check the oil level. The oil should be between the two marks on the dipstick.
9. If necessary, add more oil:
 - 9.1. Remove the filler cap.
 - 9.2. Add the recommended oil slowly through the filler point.
 - 9.3. Replace the dipstick.
 - 9.4. Remove the dipstick.
 - 9.5. Check the oil level, if necessary add more oil.
 - 9.6. Replace the dipstick.
 - 9.7. Replace the filler cap.

Coolant – Check (Level)

CAUTION! The cooling system is pressurised when the coolant is hot. When you remove the cap, hot coolant can spray out and burn you. Make sure that the engine is cool before you work on the cooling system.

In most cases the generating set is supplied pre-filled with radiator coolant. Before starting and also as part of a regular maintenance schedule it is important to check the level of coolant in the radiator, and replenish as necessary.

1. Make the machine safe.
2. Let the engine cool.
3. Get access to the radiator filler cap and expansion bottle.
4. Check the level of coolant in the radiator and in the expansion bottle. If necessary, top-up the system:
 - 4.1. Carefully remove the filler cap.
 - 4.2. If necessary top-up the coolant to the neck of the expansion tube.
 - 4.3. If necessary top-up the coolant in the expansion bottle so that it is half full.
 - 4.4. Install the filler cap, make sure that it is tight.

Fig 17

- A** Coolant filler
- B** Expansion tank
- C** High-pressure turbo charger
- D** Air filter
- E** Air filter indicator
- F** Low-pressure turbo charger
- G** Charge air cooler (low pressure turbo)
- H** Oil sump
- J** Radiator

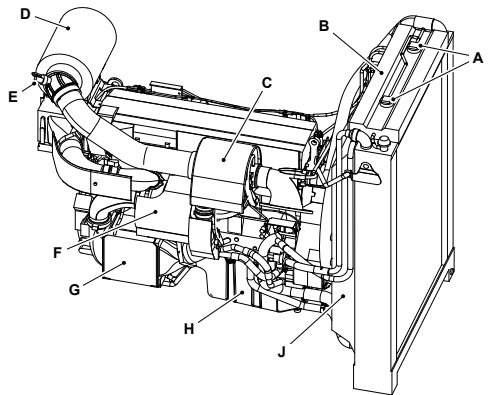

Service checks

Air Filter – Check (Condition)

Engine performance and durability will be severely affected if the quality of the air intake is poor.

A dirty and blocked air cleaner element will reduce the amount of air entering the combustion chamber which can cause engine mis-firing, black smoke and low output power.

The engine is equipped with electronic air filter indication.

1. Make the machine safe.
2. Get access to the air filter.
3. Check the system hoses for:
 - 3.1. Condition.
 - 3.2. Damage.
 - 3.3. Security.
4. Replace the system hoses if necessary.
5. No cleaning or re-use is permissible.

Fig 18

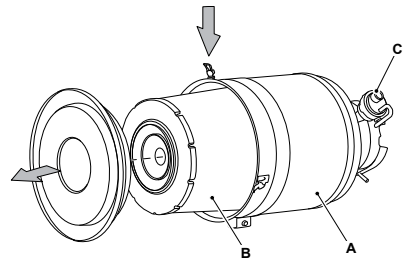

- A** Air filter
B Inner element
C Electronic blockage sensor

Dust Valve – Check (Condition)

- > Check the dust valve for rips/tears.
- > Check there are no obstructions.
- > Check that the dust valve is free of dirt and dust.
- > Check that the dust valve is securely attached to the air filter housing.

Refer to the machine's operator handbook for the air filter element removal and replacement procedures.



JCB Sales Limited, Rokester, Staffordshire, United Kingdom ST14 5JP Tel: +44 1889 590312

Download the very latest information on this product range at: www.jcb.com

All rights reserved. No part of this publication may be reproduced, stored in a retrieval system, or transmitted in any form or by any other means, electronic, mechanical, photocopying or otherwise, without prior permission from JCB Sales. All references in this publication to operating weights, sizes, capacities and other performance measurements are provided for guidance only and may vary dependant upon the exact specification of the machine. They should not therefore be relied upon in relation to suitability for a particular application.

Guidance and advice should always be sought from your JCB Dealer. JCB reserves the right to change specifications without notice. Illustrations and specifications shown may include optional equipment and accessories.